

# VMEX Series

## Modular VRF Outdoor Unit

### Technical Manual

**460~480V/3/60Hz**



# CONTENTS

**Part 1 General Information..... 3**

**Part 2 Outdoor Unit Engineering Data ..... 21**

**Part 3 System Design and Installation..... 157**

# Part 1

## General Information

- 1 Indoor and Outdoor Unit Capacities ..... 4
- 2 External Appearance..... 6
- 3 Outdoor Unit Combinations..... 8
- 4 Nomenclature..... 9
- 5 Combination Ratio..... 14
- 6 Selection Procedure..... 15

## 1 Indoor and Outdoor Unit Capacities

### 1.1 Indoor Units

#### 1.1.1 Standard indoor units

Table 1-1.1: Standard indoor unit abbreviation codes

Abbreviation code	Type
VECW	One-way Cassette
VECT	Two-way Cassette
VECM	Compact Four-way Cassette
VECR	Four-way Cassette
VEMP	Medium Static Pressure Duct

Abbreviation code	Type
VEHP	High Static Pressure Duct
VEWM	Wall-mounted
VEFC	Ceiling & Floor
VEFB	Floor Standing

Table 1-1.2: Standard indoor unit capacity range

Capacity		Capacity index	VECW	VECT	VECM	VECR	VEMP	VEHP	VEWM	VEFC	VEFB
kW	HP										
1.8	0.6	18	18	—	—	—	—	—	—	—	—
2.2	0.8	22	22	22	22	—	22	—	22	—	22
2.8	1	28	28	28	28	28	28	—	28	—	28
3.6	1.25	36	36	36	36	36	36	—	36	36	36
4.5	1.6	45	45	45	45	45	45	—	45	45	45
5.6	2	56	56	56	—	56	56	—	56	56	56
7.1	2.5	71	71	71	—	71	71	71	71	71	71
8.0	3	80	—	—	—	80	80	80	80	80	80
9.0	3.2	90	—	—	—	90	90	90	90	90	—
10.0	3.6	100	—	—	—	100	—	—	—	—	—
11.2	4	112	—	—	—	112	112	112	—	112	—
14.0	5	140	—	—	—	140	140	140	—	140	—
16.0	6	160	—	—	—	—	—	160	—	160	—
20.0	7	200	—	—	—	—	—	200	—	—	—
25.0	9	250	—	—	—	—	—	250	—	—	—
28.0	10	280	—	—	—	—	—	280	—	—	—
40.0	14	400	—	—	—	—	—	400	—	—	—
45.0	16	450	—	—	—	—	—	450	—	—	—
56.0	20	560	—	—	—	—	—	560	—	—	—

#### 1.1.2 Fresh air processing unit

Table 1-1.3: Fresh air processing unit capacity range

Capacity	12.5kW	14kW	20kW	25kW	28kW	45kW	56kW
Capacity index	125	140	200	250	280	450	560

### 1.2 Heat recovery ventilator

Table 1-1.4: Heat recovery ventilator capacity range

Capacity	200m <sup>3</sup> /h	300m <sup>3</sup> /h	400m <sup>3</sup> /h	500m <sup>3</sup> /h	800m <sup>3</sup> /h	1000m <sup>3</sup> /h	1500m <sup>3</sup> /h	2000m <sup>3</sup> /h
----------	----------------------	----------------------	----------------------	----------------------	----------------------	-----------------------	-----------------------	-----------------------

### 1.3 Outdoor Units

Table 1-1.5: Outdoor unit capacity range

Model	VMEX008Q8A	VMEX009Q8A	VMEX010Q8A	VMEX012Q8A	VMEX014Q8A	VMEX016Q8A	VMEX018Q8A	VMEX020Q8A
<b>Capacity</b>	X252W	X280W	X335W	X400W	X450W	X500W	X560W	X615W

Model	VMEX022Q8A	VMEX024Q8A	VMEX026Q8A	VMEX028Q8A	VMEX029Q8A	VMEX030Q8A	VMEX032Q8A	VMEX034Q8A
<b>Capacity</b>	X670W	X730W	X780W	X840W	X895W	X950W	X1000W	X1065W
Outdoor unit 1	12HP	10HP	10HP	10HP	10HP	12HP	18HP	16HP
Outdoor unit 2	12HP	16HP	18HP	20HP	22HP	22HP	18HP	22HP

Model	VMEX036Q8A	VMEX038Q8A	VMEX040Q8A	VMEX042Q8A	VMEX044Q8A	VMEX046Q8A	VMEX048Q8A	VMEX050Q8A
<b>Capacity</b>	X1115W	X1175W	X1230W	X1285W	X1345W	X1395W	X1455W	X1510W
Outdoor unit 1	18HP	20HP	22HP	12HP	10HP	10HP	10HP	10HP
Outdoor unit 2	22HP	22HP	22HP	12HP	16HP	18HP	20HP	22HP
Outdoor unit 3	—	—	—	22HP	22HP	22HP	22HP	22HP

Model	VMEX052Q8A	VMEX054Q8A	VMEX056Q8A	VMEX058Q8A	VMEX060Q8A	VMEX062Q8A	VMEX064Q8A	VMEX066Q8A
<b>Capacity</b>	X1565W	X1615W	X1680W	X1730W	X1790W	X1845W	X1900W	X1960W
Outdoor unit 1	12HP	18HP	16HP	18HP	20HP	22HP	12HP	10HP
Outdoor unit 2	22HP	18HP	22HP	22HP	22HP	22HP	12HP	16HP
Outdoor unit 3	22HP	22HP	22HP	22HP	22HP	22HP	22HP	22HP
Outdoor unit 4	—	—	—	—	—	—	22HP	22HP

Model	VMEX068Q8A	VMEX070Q8A	VMEX072Q8A	VMEX074Q8A	VMEX076Q8A	VMEX078Q8A	VMEX080Q8A	VMEX082Q8A
<b>Capacity</b>	X2010W	X2070W	X2125W	X2180W	X2230W	X2295W	X2345W	X2405W
Outdoor unit 1	10HP	10HP	10HP	12HP	18HP	16HP	18HP	20HP
Outdoor unit 2	18HP	20HP	22HP	22HP	18HP	22HP	22HP	22HP
Outdoor unit 3	22HP	22HP	22HP	22HP	22HP	22HP	22HP	22HP
Outdoor unit 4	22HP	22HP	22HP	22HP	22HP	22HP	22HP	22HP

Model	VMEX084Q8A
<b>Capacity</b>	X2460W
Outdoor unit 1	22HP
Outdoor unit 2	22HP
Outdoor unit 3	22HP
Outdoor unit 4	22HP

Notes:









1. The full model names can be obtained by substituting the asterisk in the model name format given in the left-hand column of the table above with the shortened model names given in the table.
2. The combinations of units shown in the table are factory-recommended. Other combinations of units are also possible.

## 2 External Appearance

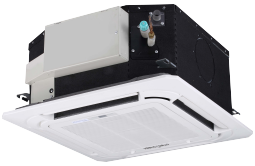
### 2.1 Indoor Units

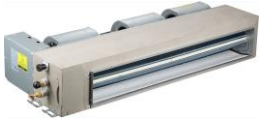
#### 2.1.1 Standard indoor unit

Table 1-2.1: Standard indoor unit appearance

<p>One-way Cassette</p> <p>VECW</p> 	<p>Two-way Cassette</p> <p>VECT</p> 
<p>Compact Four-way Cassette</p> <p>VECM</p> 	<p>Four-way Cassette</p> <p>VECR</p> 
<p>Low Static Pressure Duct</p> <p>VELP</p> 	<p>Medium Static Pressure Duct</p> <p>VEMP</p> 
<p>High Static Pressure Duct</p> <p>VEHP</p> 	<p>Wall-mounted</p> <p>VEWM</p> 
<p>Floor Ceiling</p> <p>VEFC</p> 	<p>Floor Standing</p> <p>VEFB</p> 

#### 2.1.2 Fresh air processing unit

Table 1-2.2: Fresh air processing unit appearance

<p>Fresh Air Processing Unit</p> <p>VEFA</p> 
--

### 2.2 Heat Recovery Ventilator



Table 1-2.3: Heat recovery ventilator appearance

<p>Heat Recovery Ventilator</p> 
---

**2.3 Outdoor Units**

**2.3.1 Single units**

*Table 1-2.4: Single outdoor unit appearance*

VMEX008,009,010	VMEX012,014,016,018,020
	

# VMEX VRF 460V 60Hz

## 3 Outdoor Unit Combinations

Table 1-3.1: Outdoor unit combinations

System capacity		Number of units	Modules <sup>1</sup>								Outdoor branch joint kit <sup>2</sup>
kW	HP		8	10	12	14	16	18	20	22	
25.2	8	1	•								—
28.0	10	1		•							
33.5	12	1			•						
40.0	14	1				•					
45.0	16	1					•				
50.0	18	1						•			
56.0	20	1							•		
61.5	22	1								•	
67.0	24	2			••						
73.0	26	2		•			•				
78.0	28	2		•				•			
84.0	30	2		•					•		
89.5	32	2		•						•	
95.0	34	2			•					•	
100.0	36	2						••			
106.5	38	2					•			•	
111.5	40	2						•		•	
117.5	42	2							•	•	
123.0	44	2								••	VAMC003-DDF
128.5	46	3			••					•	
134.5	48	3		•			•			•	
139.5	50	3		•				•		•	
145.5	52	3		•					•	•	
151.0	54	3		•						••	
156.5	56	3			•					••	
161.5	58	3						••		•	
168.0	60	3					•			••	
173.0	62	3						•		••	
179.0	64	3							•	••	
184.5	66	3								•••	VAMC004-DDF
190.0	68	4			••					••	
196.0	70	4		•			•			••	
201.0	72	4		•				•		••	
207.0	74	4		•					•	••	
212.5	76	4		•						•••	
218.0	78	4			•					•••	
223.0	80	4						••		••	
229.5	82	4					•			•••	
234.5	84	4						•		•••	
240.5	86	4							•	•••	
246.0	88	4								••••	

Notes:

1. The combinations of units shown in the table are factory-recommended. Other combinations of units are also possible.
2. For systems with two or more outdoor units, outdoor branch joints (sold separately) are required.



# VMEX VRF 460V 60Hz

## 5 Combination Ratio

$$\text{Combination ratio} = \frac{\text{Sum of capacity indexes of the indoor units}}{\text{Capacity index of the outdoor units}}$$

Table 1-5.1: Indoor and outdoor unit combination ratio limitations

Type	Minimum combination ratio	Maximum combination ratio		
		Standard indoor units only	Fresh air processing units only	Fresh air processing units and standard indoor units together
V5 X Series outdoor units	50%	130%	100%	100% <sup>1</sup>

Notes:

- When fresh air processing units are installed together with standard indoor units, the total capacity of the fresh air processing units must not exceed 30% of the total capacity of the outdoor units and the combination ratio must not exceed 100%.

Table 1-5.2: Combinations of Indoor and outdoor units

Outdoor unit capacity			Sum of capacity indexes of connected indoor units (standard indoor units only)	Sum of capacity indexes of connected indoor units (fresh air processing units and standard indoor units together)	Maximum number of connected indoor units
kW	HP	Capacity index			
25.2	8	252	126 to 327.6	126 to 252	13
28.0	10	280	140 to 364	140 to 280	16
33.5	12	335	167.5 to 435.5	167.5 to 335	20
40.0	14	400	200 to 520	200 to 400	23
45.0	16	450	225 to 585	225 to 450	26
50.0	18	500	250 to 650	250 to 500	29
56.0	20	560	280 to 728	280 to 560	33
61.5	22	615	307.5 to 799.5	307.5 to 615	36
67.0	24	670	335 to 871	335 to 670	39
73.0	26	730	365 to 949	365 to 730	43
78.0	28	780	390 to 1014	390 to 780	46
84.0	30	840	420 to 1092	420 to 840	50
89.5	32	895	447.5 to 1163.5	447.5 to 895	53
95.0	34	950	475 to 1235	475 to 950	56
100.0	36	1000	500 to 1300	500 to 1000	59
106.5	38	1065	532.5 to 1384.5	532.5 to 1065	63
111.5	40	1115	557.5 to 1449.5	557.5 to 1115	64
117.5	42	1175	587.5 to 1527.5	587.5 to 1175	
123.0	44	1230	615 to 1599	615 to 1230	
128.5	46	1285	642.5 to 1670.5	642.5 to 1285	
134.5	48	1345	672.5 to 1748.5	672.5 to 1345	
139.5	50	1395	697.5 to 1813.5	697.5 to 1395	
145.5	52	1455	727.5 to 1891.5	727.5 to 1455	
151.0	54	1510	755 to 1963	755 to 1510	
156.5	56	1565	782.5 to 2034.5	782.5 to 1565	
161.5	58	1615	807.5 to 2099.5	807.5 to 1615	
168.0	60	1680	840 to 2184	840 to 1680	
173.0	62	1730	865 to 2249	865 to 1730	
179.0	64	1790	895 to 2327	895 to 1790	
184.5	66	1845	922.5 to 2398.5	922.5 to 1845	
190.0	68	1900	950 to 2470	950 to 1900	
196.0	70	1960	980 to 2548	980 to 1960	
201.0	72	2010	1005 to 2613	1005 to 2010	
207.0	74	2070	1035 to 2691	1035 to 2070	
212.5	76	2125	1062.5 to 2762.5	1062.5 to 2125	
218.0	78	2180	1090 to 2834	1090 to 2180	
223.0	80	2230	1115 to 2899	1115 to 2230	
229.5	82	2295	1147.5 to 2983.5	1147.5 to 2295	
234.5	84	2345	1172.5 to 3048.5	1172.5 to 2345	
240.5	86	2405	1202.5 to 3126.5	1202.5 to 2405	
246.0	88	2460	1230 to 3198	1230 to 2460	

## 6 Selection Procedure

### 6.1 Procedure

#### Step 1: Establish design conditions

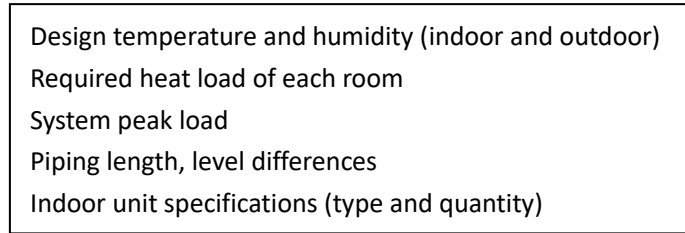

#### Step 2: Select indoor units

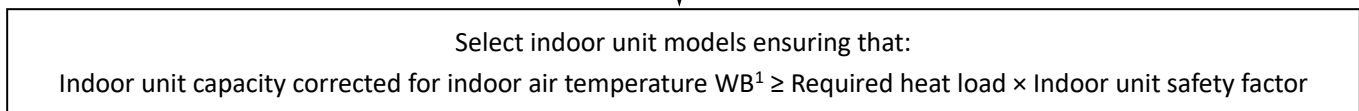
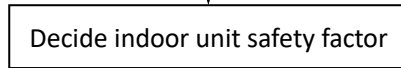

#### Step 3: Select outdoor units

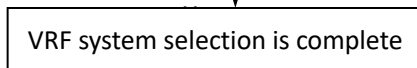
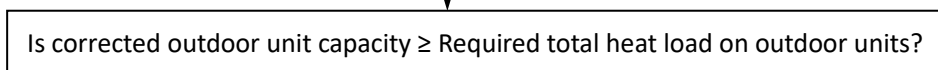
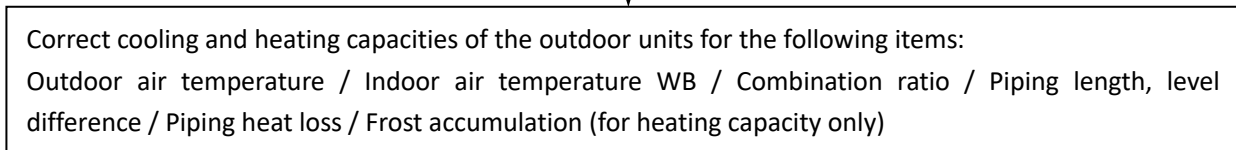
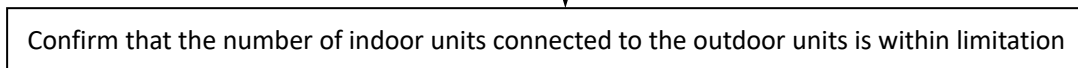
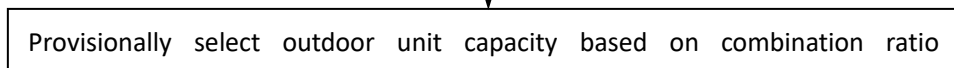
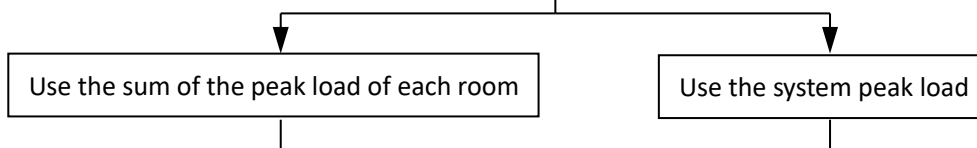
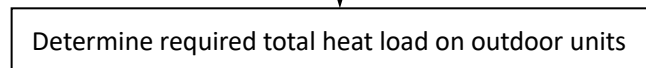

Notes:  
 1. If the indoor design temperature falls between two temperatures listed in the indoor unit's capacity table, calculate the corrected capacity by interpolation. If the indoor unit selection is to be based on total heat load and sensible heat load, select indoor units which satisfy not only the total head load requirements of each room but also the sensible heat load requirements of each room. As with total heat capacity, the sensible heat capacity of indoor units should be corrected for indoor temperature, interpolating where necessary. For the indoor unit capacity tables, refer to the indoor unit technical manuals.

# VMEX VRF 460V 60Hz

## 6.2 Example

The following is a selection example based on total heat load for cooling.

Figure 1-6.1: Room plan

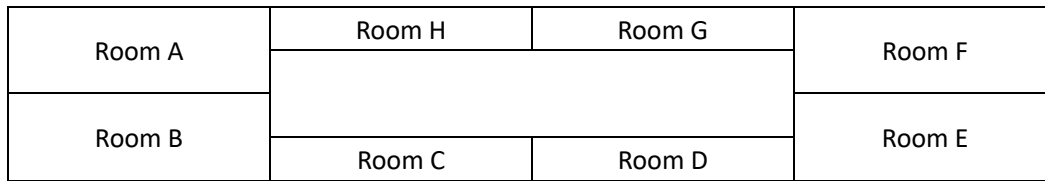

### Step 1: Establish design conditions

- Indoor air temperature 25°C DB, 18°C WB; outdoor air temperature 33°C DB.
- Determine peak load of each room and system peak load. As shown in Table 1-6.1, the system peak load is 50.7kW.

Table 1-6.1: Required heat load of each room (kW)

Time	Room A	Room B	Room C	Room D	Room E	Room F	Room G	Room H	Total
9:00	4.8	4.8	3.0	3.0	9.1	9.0	2.9	2.9	39.5
12:00	6.6	7.1	5.1	5.1	7.4	6.8	4.0	4.0	46.1
14:00	9.0	9.4	4.9	4.9	7.3	6.8	4.2	4.2	50.7
16:00	10.6	10.7	3.9	3.9	6.3	6.2	3.8	3.8	49.2

- The maximum piping lengths and level differences in this example are as given in Figure 1-6.2.

Figure 1-6.2: System diagram

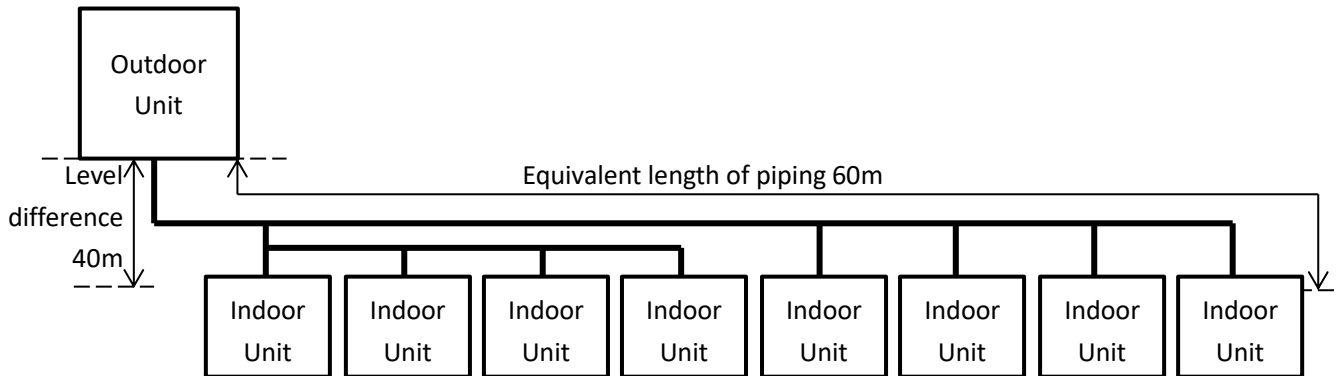

- Indoor unit type for all rooms: medium static pressure duct (T2).

### Step 2: Select indoor units

- In this example, a safety factor is not used (i.e. the safety factor is 1).
- Select indoor unit models using the medium static pressure duct cooling capacity table. Each indoor unit's corrected capacity needs to be greater than or equal to the peak load of the relevant room. The selected indoor units are shown in Table 1-6.3.

Table 1-6.2: Extract from medium static pressure duct (T2) cooling capacity table

Model	Capacity index	Indoor air temperature													
		14°C WB		16°C WB		18°C WB		19°C WB		20°C WB		22°C WB		24°C WB	
		20°C DB		23°C DB		26°C DB		27°C DB		28°C DB		30°C DB		32°C DB	
		TC	SHC	TC	SHC	TC	SHC	TC	SHC	TC	SHC	TC	SHC	TC	SHC
T2	22	1.5	1.4	1.8	1.5	2.1	1.6	2.2	1.6	2.3	1.7	2.4	1.5	2.4	1.5
	28	1.9	1.7	2.3	1.9	2.6	2.1	2.8	2.1	3.0	2.1	3.1	2.0	3.1	1.9
	36	2.5	2.1	2.9	2.3	3.4	2.5	3.6	2.6	3.8	2.7	4.2	2.8	3.9	2.3
	45	3.1	2.6	3.7	2.8	4.2	3.1	4.5	3.2	4.8	3.2	4.9	3.1	5.1	2.9
	56	3.9	3.0	4.6	3.3	5.3	3.6	5.6	3.7	5.9	3.8	6.2	3.7	6.2	3.4
	71	4.9	3.9	5.8	4.3	6.7	4.7	7.1	4.9	7.5	4.8	7.8	4.6	7.8	4.3
	80	5.5	4.4	6.6	4.9	7.5	5.3	8.0	5.5	8.4	5.5	8.8	5.2	8.8	4.8
	90	6.2	5.3	7.3	5.8	8.4	6.3	9.0	6.4	9.6	6.5	9.9	6.1	9.9	5.7
	112	7.7	6.4	9.1	7.1	10.5	7.7	11.2	7.8	11.9	8.1	12.5	7.8	12.5	7.4
	140	9.7	7.8	11.3	8.6	13.2	9.6	14.0	9.8	14.8	9.8	15.7	9.7	15.4	8.8

Abbreviations:

TC: Total capacity (kW); SHC: Sensible heat capacity (kW)

Table 1-6.3: Selected indoor units

	Room A	Room B	Room C	Room D
Peak heat load (kW)	10.6	10.7	5.1	5.1
Selected indoor unit	VEMP048Q0A-DCV140	VEMP048Q0A-DCV140	VELP019Q0A-DCV056	VELP019Q0A-DCV056
Corrected TC (kW)	13.2	13.2	5.3	5.3
	Room E	Room F	Room G	Room H
Peak heat load (kW)	9.1	9.0	4.2	4.2
Selected indoor unit	VEMP038Q0A-DCV112	VEMP038Q0A-DCV112	VELP015Q0A-DCV045	VELP015Q0A-DCV045
Corrected TC (kW)	10.5	10.5	4.2	4.2

**Step 3: Select outdoor units**

- Determine the required total heat load from the indoor units to the outdoor units based on either the sum of the peak loads of each room or the system peak load. In this example, it is determined based on the system peak load. Therefore, the required heat load is 50.7kW.
- Provisionally select outdoor units using the sum of the capacity indexes (CIs) of the selected indoor units (as shown in Table 1-6.4), ensuring that the combination ratio is between 50% and 130%. Refer to Table 1-6.5. As the sum of CIs of the indoor units is 706, outdoor units from 20HP to 50HP are potentially suitable. Start from the smallest, which is the 20HP unit.

Table 1-6.4: Sum of indoor unit capacity indexes

Model	Capacity Index	No. of units
VEMP048Q0A-DCV140	140	2
VEMP038Q0A-DCV112	112	2
VELP019Q0A-DCV056	56	2
VELP015Q0A-DCV045	45	2
<b>Sum of CIs</b>	<b>706</b>	

# VMEX VRF 460V 60Hz

Table 1-6.5: Extract from Table 1-5.2 Combinations of Indoor and outdoor units

kW	HP	Capacity index	Sum of capacity indexes of connected indoor units	Maximum number of connected indoor units
50.0	18	500	250 to 650	29
56.0	20	560	280 to 728	33
61.5	22	615	307.5 to 799.5	36
67.0	24	670	335 to 871	39
73.0	26	730	365 to 949	43
78.0	28	780	390 to 1014	46
84.0	30	840	420 to 1092	50
89.5	32	895	447.5 to 1163.5	53
95.0	34	950	475 to 1235	56
100.0	36	1000	500 to 1300	59
106.5	38	1065	532.5 to 1384.5	63
111.5	40	1115	557.5 to 1449.5	64
117.5	42	1175	587.5 to 1527.5	
123.0	44	1230	615 to 1599	
128.5	46	1285	642.5 to 1670.5	
134.5	48	1345	672.5 to 1748.5	
139.5	50	1395	697.5 to 1813.5	
145.5	52	1455	727.5 to 1891.5	

- The number of connected indoor units is 8 and the maximum number of connected indoor units on the 20HP outdoor unit is 33, so the number of connected indoor units is within the limitation.
- Calculate the corrected capacity of the outdoor units:
  - a) The sum of the indoor unit CIs is 706 and the CI of the 20HP outdoor unit (VMEX018Q8A-D33V560) is 560, so the combination ratio is  $706 / 560 = 126\%$ .
  - b) Using the outdoor units' cooling capacity table, interpolate to obtain the capacity ("B") corrected for outdoor air temperature, indoor air temperature, and combination ratio. Refer to Tables 1-6.6 and 1-6.7.

Table 1-6.6: Extract from Table 2-8.7 VMEX018Q8A-D33V560 cooling capacity

CR	Outdoor air temp. (°C DB)	Indoor air temp. (°C DB / °C WB)	
		25.8 / 18.0	
		TC	PI
		kW	kW
130%	31	60.0	13.69
	33	59.2	14.20
	35	58.2	14.73
120%	31	59.0	13.61
	33	58.2	14.12
	35	57.2	14.63

Table 1-6.7: Cooling capacity calculated by interpolation

CR	Outdoor air temp. (°C DB)	Indoor air temp. (°C DB / °C WB)	
		25.8 / 18.0	
		TC	PI
		kW	kW
130%			
	33	59.2	14.20
	<b>B = 58.8<sup>1</sup></b>		
120%			
	33	58.2	14.12

Notes:

1.  $58.2 + (59.2 - 58.2) \times (126 - 120) / (130 - 120) = 58.8$ .

c) Find the correction factor for piping length and level difference (“K1”)

Figure 1-6.3: VMEX018Q8A-D33V560 rate of change in cooling capacity

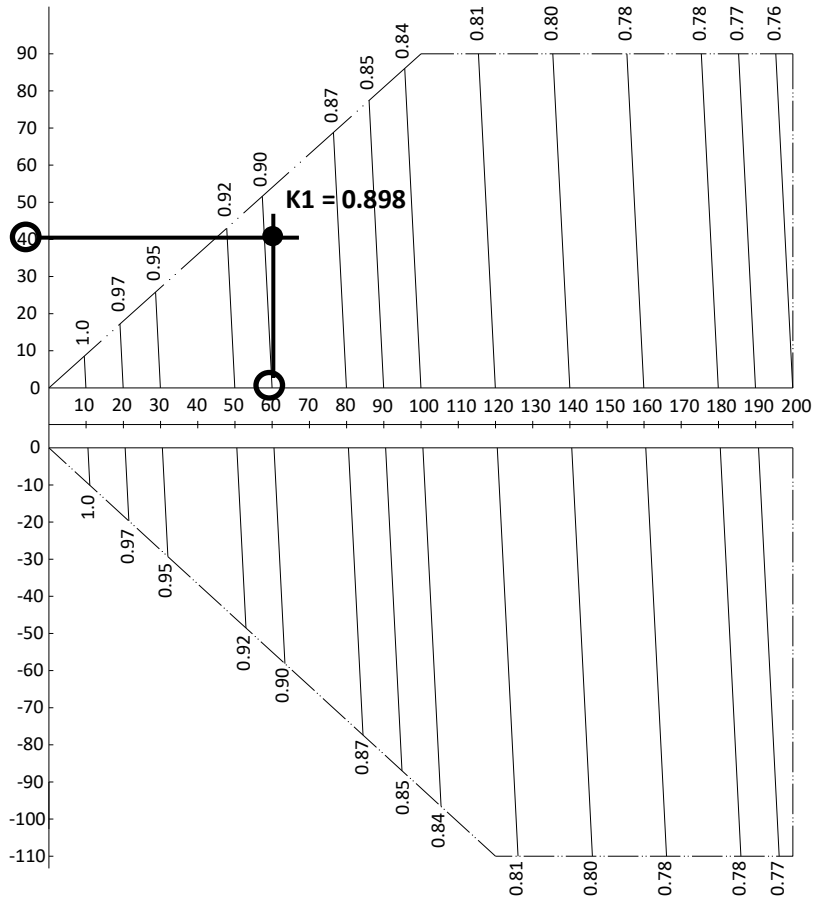

Notes:

1. The horizontal axis shows equivalent length of piping between farthest indoor unit and first outdoor branch joint; the vertical axis shows the largest level difference between indoor unit and outdoor unit. For level differences, positive values indicate that the outdoor unit is above the indoor unit, negative values indicate that the outdoor unit is below the indoor unit.

d) Calculate the corrected capacity of VMEX018Q8A-D33V560 by using K1:

$$C = B \times K1 = 58.8 \times 0.898 = 52.8\text{kW}$$

- The corrected capacity 52.8kW is larger than required total heat load 50.7kW, so selection is complete. (In the event that the corrected capacity is lower than the required total heat load, Step 3 should be repeated from the point where the outdoor unit capacity is provisionally selected.)

# Part 2

# Outdoor Unit

# Engineering Data

- 1 Specifications ..... 22
- 2 Dimensions..... 36
- 3 Installation Space Requirements..... 43
- 4 Piping Diagrams..... 44
- 5 Wiring Diagrams ..... 46
- 6 Electrical Characteristics ..... 48
- 7 Functional Components and Safety Devices..... 49
- 8 Capacity Tables ..... 50
- 9 Operating Limits ..... 152
- 10 Sound Levels..... 153
- 11 Accessories ..... 155

# VMEX 460V 60Hz

## 1 Specifications

### VMEX008Q8A-D13V224/ VMEX009Q8A-D16V280/ VMEX010Q8A-D20V335

Table 2-1.1: VMEX008(009,010)Q8A specifications

HP		8		10		12	
Model name		VMEX008Q8A-D13V224		VMEX009Q8A-D16V280		VMEX010Q8A-D20V335	
Power supply		3 phase, 460V, 60Hz					
Cooling <sup>1</sup>	Capacity	kW	25.2	28	33.5		
		kBtu/h	86	95.5	114.3		
	Power input	kW	5.36	6.22	7.79		
	EER		4.7	4.5	4.3		
Heating <sup>2</sup>	Capacity	kW	27	31.5	37.5		
		kBtu/h	92.1	107.5	128		
	Power input	kW	4.82	5.94	7.65		
	COP		5.6	5.3	4.9		
Connected indoor units	Total capacity		50-130% of outdoor unit capacity				
	Maximum quantity		13	16	20		
Compressors	Type		DC inverter				
	Quantity		1				
	Oil type		FV68H				
	Start-up method		Soft start				
Fans	Type		Propeller				
	Motor type		DC				
	Quantity		1				
	Insulation class		E				
	Safety class		IP23				
	Motor input	W	618				
	Motor output	W	490				
	Airflow rate	m <sup>3</sup> /h	12000				
	Static pressure	Pa (in. W.G.)	0-20 (0-0.08) (default)				
		Pa (in. W.G.)	20-60 (0.08-0.24) (customized)				
Drive type		Direct					
Refrigerant	Type		R410A				
	Factory charge	kg (lbs.)	9 (20)	9 (20)	11 (24)		
Pipe connections <sup>3</sup>	Liquid pipe	mm (in.)	Φ12.7 (Φ1/2)	Φ12.7 (Φ1/2)	Φ15.9 (Φ5/8)		
	Gas pipe	mm (in.)	Φ25.4 (Φ1)	Φ25.4 (Φ1)	Φ28.6 (Φ1-1/8)		
	Oil balance pipe	mm (in.)	Φ6.35 (Φ1/4)				
Sound pressure level <sup>4</sup>		dB(A)	58	59	60		
Net dimensions (W×H×D)	mm		990×1635×790				
	in.		39×64-3/8×31-1/8				
Packed dimensions (W×H×D)	mm		1090×1805×860				
	in.		42-7/8×71-1/16×33-7/8				
Net weight		kg (lbs.)	229 (505)	229 (505)	247 (543)		
Gross weight		kg (lbs.)	249 (548)	249 (548)	267 (587)		
Operating temperature range		°C (°F)	Cooling: -5 to 48 (23 to 118.4); heating: -20 to 24 (-4 to 75.2)				
Safety devices	High/low pressure switch, fan driver overload protector, overcurrent relay, inverter overload protector, overvoltage protector						
Standard accessories	Installation manual, operation manual, connection pipes, clamps						

Notes:

- Indoor air temperature 27°C (80.6°F) DB, 19°C (66.2°F) WB; outdoor air temperature 35°C (95.0°F) DB; equivalent refrigerant piping length 7.5m (24.6ft.) with zero level difference.
- Indoor air temperature 20°C (68.0°F) DB; outdoor air temperature 7°C (44.6°F) DB, 6°C (42.8°F) WB; equivalent refrigerant piping length 7.5m (24.6ft.) with zero level difference.
- Diameters given are those of the unit's stop valve.
- Sound pressure level is measured at a position 1m (3.28ft.) in front of the unit and 1.3m (4.26ft.) above the floor in a semi-anechoic chamber.

Conversion Formulae:  
 kBtu/h = kW × 3.412;  
 in.W.G. = Pa × 0.004;  
 lbs. = kg × 2.2;  
 in. = mm / 25.4



VMEX012Q8A-D23V400/ VMEX014Q8A-D26V450/ VMEX016Q8A-D29V500

Table 2-1.2: VMEX012(014,016)Q8A specifications

HP			14	16	18
Model name			VMEX012Q8A-D23V400	VMEX014Q8A-D26V450	VMEX016Q8A-D29V500
Power supply			3 phase, 460V, 60Hz		
Cooling <sup>1</sup>	Capacity	kW	40	45	50
		kBtu/h	136.5	153.5	170.6
	Power input	kW	9.3	10.98	12.82
	EER			4.3	4.1
Heating <sup>2</sup>	Capacity	kW	45	50	56
		kBtu/h	153.5	170.6	191.1
	Power input	kW	9.38	10.87	13.18
	COP			4.8	4.6
Connected indoor units	Total capacity		50-130% of outdoor unit capacity		
	Maximum quantity		23	26	29
Compressors	Type		DC inverter		
	Quantity		2		
	Oil type		FV68H		
	Start-up method		Soft start		
Fans	Type		Propeller		
	Motor type		DC		
	Quantity		2		
	Insulation class		E		
	Safety class		IP23		
	Motor input	W	315+310	315+310	325+315
	Motor output	W	260+250	260+250	280+270
	Airflow rate	m <sup>3</sup> /h	14000	14000	16000
	Static pressure	Pa (in. W.G.)	0-20 (0-0.08) (default)		
		Pa (in. W.G.)	20-60 (0.08-0.24) (customized)		
Drive type		Direct			
Refrigerant	Type		R410A		
	Factory charge	kg (lbs.)	13 (29)		
Pipe connections <sup>3</sup>	Liquid pipe	mm (in.)	Φ15.9 (Φ5/8)	Φ15.9 (Φ5/8)	Φ19.1 (Φ3/4)
	Gas pipe	mm (in.)	Φ31.8 (Φ1-1/4)	Φ31.8 (Φ1-1/4)	Φ31.8 (Φ1-1/4)
	Oil balance pipe	mm (in.)	Φ6.35 (Φ1/4)		
Sound pressure level <sup>4</sup>	dB(A)	62	62	63	
Net dimensions (W×H×D)	mm	1340×1635×790			
	in.	52-3/4×64-3/8×31-1/8			
Packed dimensions (W×H×D)	mm	1405×1805×855			
	in.	55-3/8×71-1/16×33-5/8			
Net weight	kg (lbs.)	326 (719)	326 (719)	334 (736)	
Gross weight	kg (lbs.)	353 (778)	353 (778)	361(796)	
Operating temperature range	°C (°F)	Cooling: -5 to 48 (23 to 118.4); heating: -20 to 24 (-4 to 75.2)			
Safety devices	High/low pressure switch, fan driver overload protector, overcurrent relay, inverter overload protector, overvoltage protector				
Standard accessories	Installation manual, operation manual, connection pipes, clamps				

Notes:

- Indoor air temperature 27°C (80.6°F) DB, 19°C (66.2°F) WB; outdoor air temperature 35°C (95.0°F) DB; equivalent refrigerant piping length 7.5m (24.6ft.) with zero level difference.
- Indoor air temperature 20°C (68.0°F) DB; outdoor air temperature 7°C (44.6°F) DB, 6°C (42.8°F) WB; equivalent refrigerant piping length 7.5m (24.6ft.) with zero level difference.
- Diameters given are those of the unit's stop valve.
- Sound pressure level is measured at a position 1m (3.28ft.) in front of the unit and 1.3m (4.26ft.) above the floor in a semi-anechoic chamber.

Conversion Formulae:  
 kBtu/h = kW × 3.412;  
 in.W.G. = Pa × 0.004;  
 lbs. = kg × 2.2;  
 in. = mm / 25.4

# VMEX 460V 60Hz

## VMEX018Q8A-D33V560/ VMEX020Q8A-D36V615

Table 2-1.3: VMEX018(020)Q8A specifications

HP			20	22
Model name			VMEX018Q8A-D33V560	VMEX020Q8A-D36V615
Power supply			3 phase, 460V, 60Hz	
Cooling <sup>1</sup>	Capacity	kW	56	61.5
		kBtu/h	191.1	209.8
	Power input	kW	14.51	16.44
	EER		3.86	3.74
Heating <sup>2</sup>	Capacity	kW	63	69
		kBtu/h	214.9	235.4
	Power input	kW	15.29	17.12
	COP		4.12	4.03
Connected indoor units	Total capacity		50-130% of outdoor unit capacity	
	Maximum quantity		33	36
Compressors	Type		DC inverter	
	Quantity		2	
	Oil type		FV68H	
	Start-up method		Soft start	
Fans	Type		Propeller	
	Motor type		DC	
	Quantity		2	
	Insulation class		E	
	Safety class		IP23	
	Motor input	W	330+320	
	Motor output	W	290+270	
	Airflow rate	m <sup>3</sup> /h	16000	
	Static pressure	Pa (in. W.G.)	0-20 (0-0.08) (default)	
		Pa (in. W.G.)	20-60 (0.08-0.24) (customized)	
Drive type		Direct		
Refrigerant	Type		R410A	
	Factory charge	kg (lbs.)	16 (35)	
Pipe connections <sup>3</sup>	Liquid pipe	mm (in.)	Φ19.1 (Φ3/4)	
	Gas pipe	mm (in.)	Φ31.8 (Φ1-1/4)	
	Oil balance pipe	mm (in.)	Φ6.35 (Φ1/4)	
Sound pressure level <sup>4</sup>		dB(A)	63	
Net dimensions (W×H×D)	mm		1340×1635×790	
	in.		52-3/4×64-3/8×31-1/8	
Packed dimensions (W×H×D)	mm		1405×1805×855	
	in.		55-3/8×71-1/16×33-5/8	
Net weight	kg (lbs.)		369 (813)	
Gross weight	kg (lbs.)		396 (873)	
Operating temperature range		°C (°F)	Cooling: -5 to 48 (23 to 118.4); heating: -20 to 24 (-4 to 75.2)	
Safety devices			High/low pressure switch, fan driver overload protector, overcurrent relay, inverter overload protector, overvoltage protector	
Standard accessories			Installation manual, operation manual, connection pipes, clamps	

Notes:

- Indoor air temperature 27°C (80.6°F) DB, 19°C (66.2°F) WB; outdoor air temperature 35°C (95.0°F) DB; equivalent refrigerant piping length 7.5m (24.6ft.) with zero level difference.
- Indoor air temperature 20°C (68.0°F) DB; outdoor air temperature 7°C (44.6°F) DB, 6°C (42.8°F) WB; equivalent refrigerant piping length 7.5m (24.6ft.) with zero level difference.
- Diameters given are those of the unit's stop valve.
- Sound pressure level is measured at a position 1m (3.28ft.) in front of the unit and 1.3m (4.26ft.) above the floor in a semi-anechoic chamber.

Conversion Formulae:  
 kBtu/h = kW × 3.412;  
 in.W.G. = Pa × 0.004;  
 lbs. = kg × 2.2;  
 in. = mm / 25.4

## 2 Dimensions

### 2.1 Single Units

VMEX008Q8A-D13V224/ VMEX009Q8A-D16V280/ VMEX010Q8A-D20V335

Figure 2-2.1: VMEX008(009,010)Q8A dimensions (unit: mm)

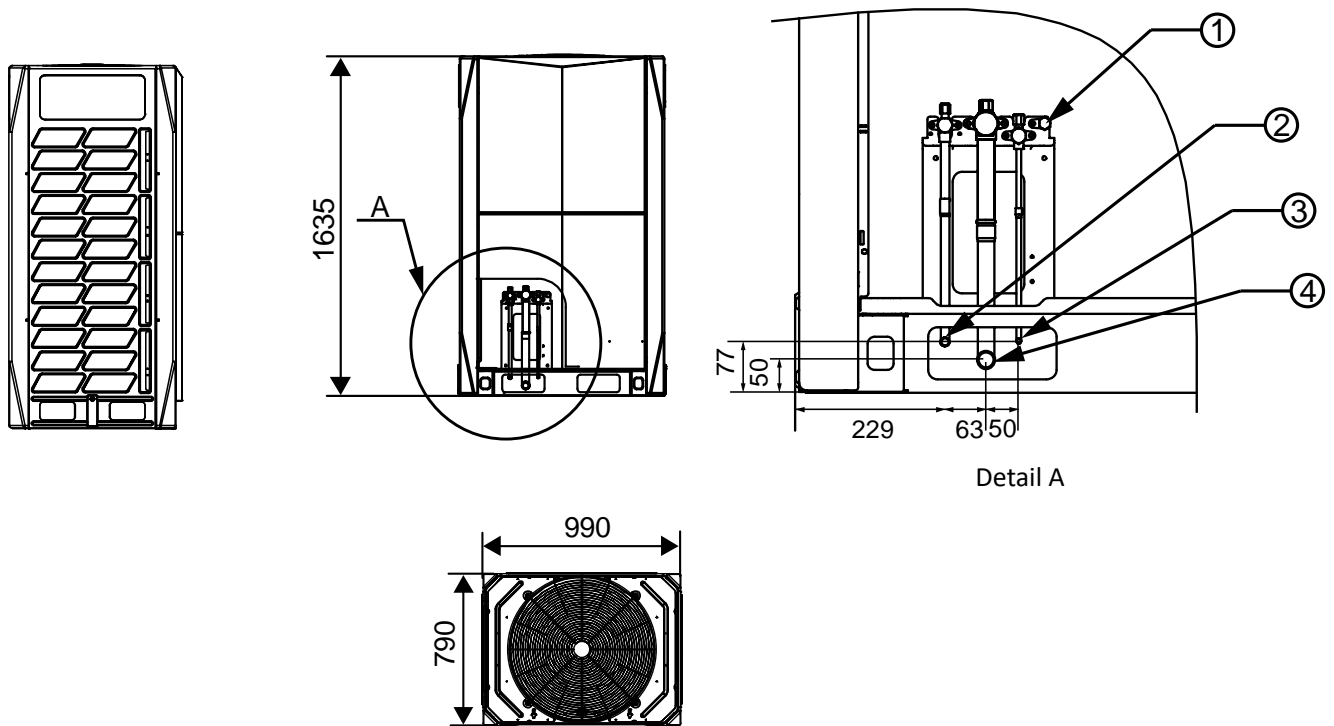

Legend		
No.	Parts name	Remarks
1	Check port	The check port is used to measure system pressure, charge refrigerant and vacuumize the system.
2	Liquid pipe connection port	Φ12.7 brazed connection on VMEX008Q8A-D13V252 / VMEX009Q8A-D16V280 Φ15.9 brazed connection on VMEX010Q8A-D20V335
3	Oil balance pipe connection port	The oil balance pipe runs between outdoor units. Φ8 brazed connection.
4	Gas pipe connection port	Φ25.4 brazed connection on VMEX008Q8A-D13V252 / VMEX009Q8A-D16V280 Φ28.6 brazed connection on VMEX010Q8A-D20V335

Figure 2-2.2: VMEX012(014,016,018,020)Q8A dimensions (unit: mm)

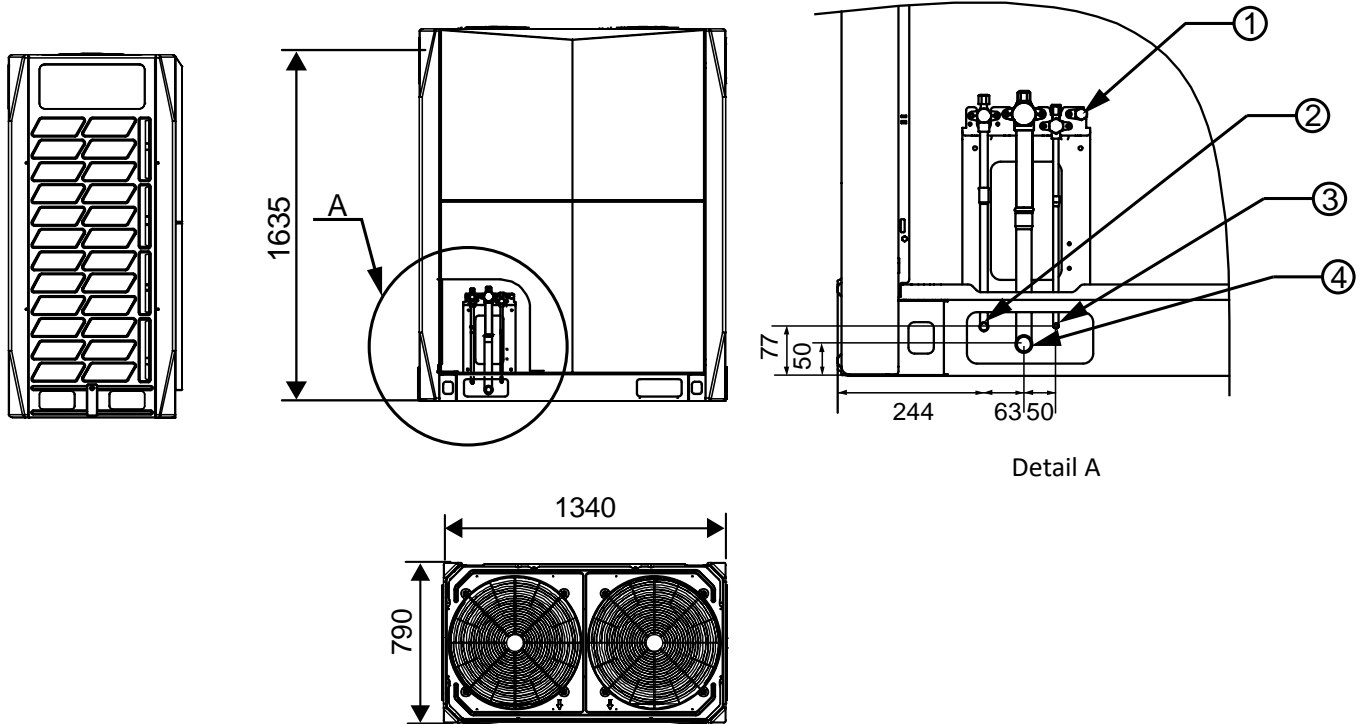

Legend		
No.	Parts name	Remarks
1	Check port	The check port is used to measure system pressure, charge refrigerant and vacuumize the system.
2	Liquid pipe connection port	Φ15.9 brazed connection on VMEX012Q8A-D23V400 / VMEX014Q8A-D26V450 Φ19.1 brazed connection on VMEX016Q8A-D29V500/ VMEX018Q8A-D33V560 / VMEX020Q8A-D36V615
3	Oil balance pipe connection port	The oil balance pipe runs between outdoor units. Φ8 brazed connection.
4	Gas pipe connection port	Φ31.8 brazed connection on VMEX012Q8A-D23V400 / VMEX014Q8A-D26V450 / VMEX016Q8A-D29V500 / VMEX018Q8A-D33V560 / VMEX020Q8A-D36V615

### 3 Installation Space Requirements

#### For single unit installation

Figure 2-3.1: Single unit installation (unit: mm)

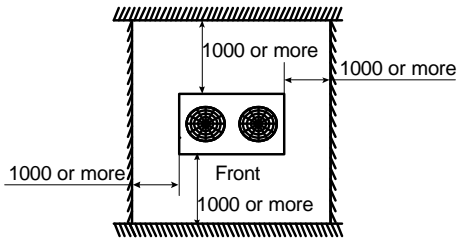

#### For single row installation

Figure 2-3.2: Single row installation (unit: mm)

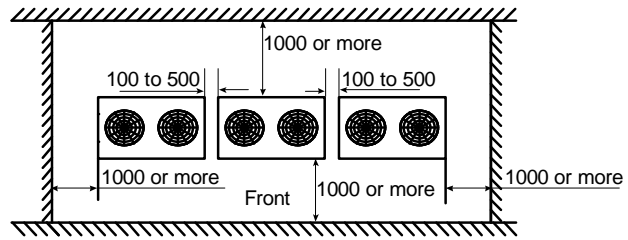

#### For multi-row installation

Figure 2-3.3: Multi-row installation (unit: mm)

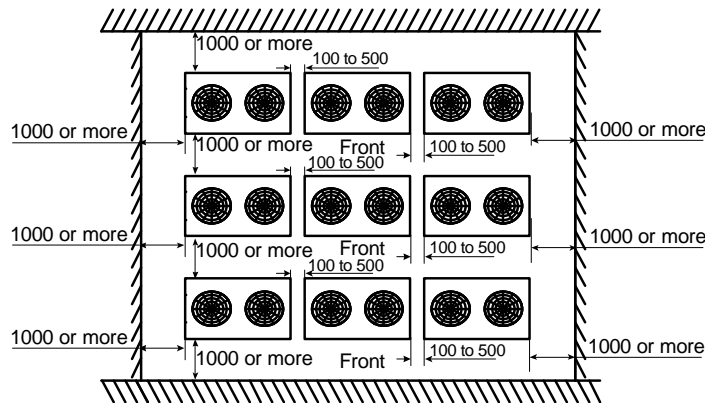

Depending on the height of adjacent walls relative to the height of the units, ducting may be required to ensure proper air discharge. In the situation depicted in Figure 2-3.4, the vertical section of ducting should be at least H-h high.

Figure 2-3.4: Top of unit below top of adjacent wall

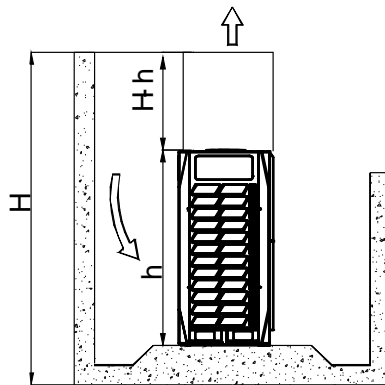

**4 Piping Diagrams**

**VMEX008Q8A-D13V224/ VMEX009Q8A-D16V280/ VMEX010Q8A-D20V335**

Figure 2-4.1: VMEX008(009,010)Q8A piping diagram

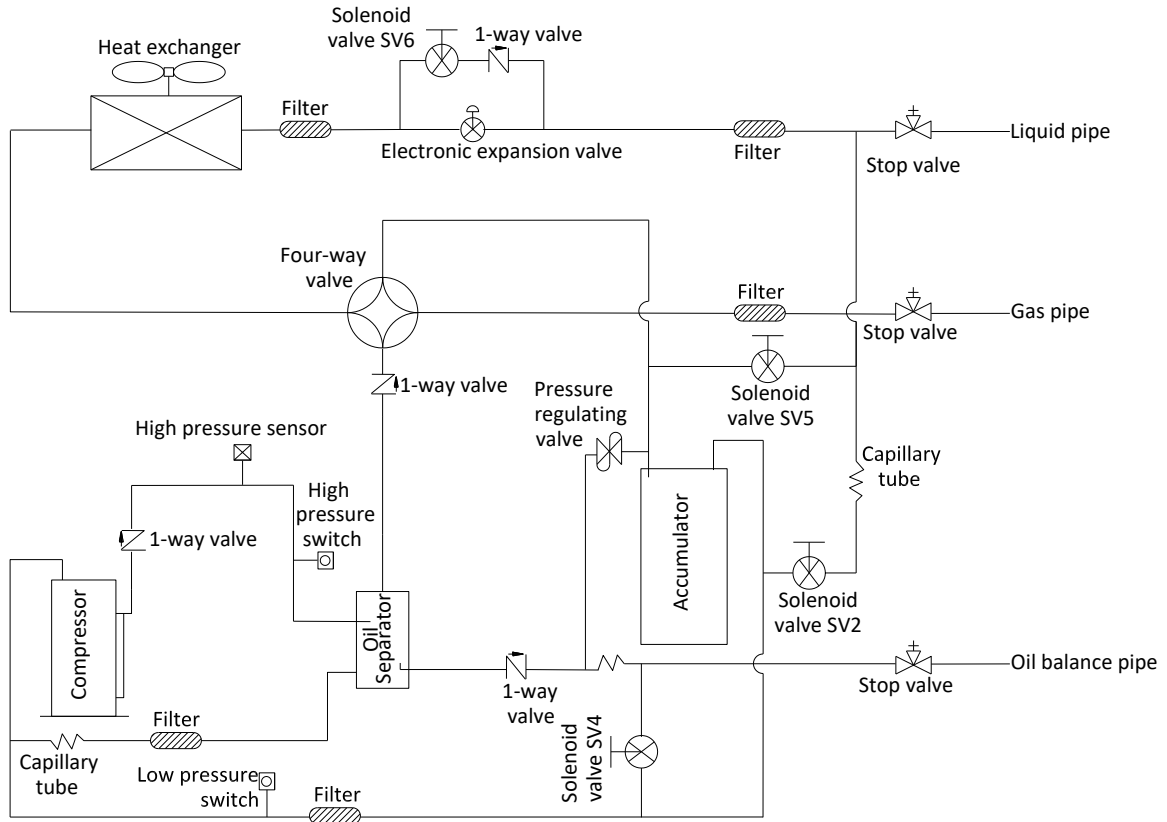

**VMEX012Q8A-D23V400/ VMEX014Q8A-D26V450/ VMEX016Q8A-D29V500/ VMEX018Q8A-D33V560/ VMEX020Q8A-D36V615**

Figure 2-4.2: VMEX012(014,016,018,020)Q8A piping diagram

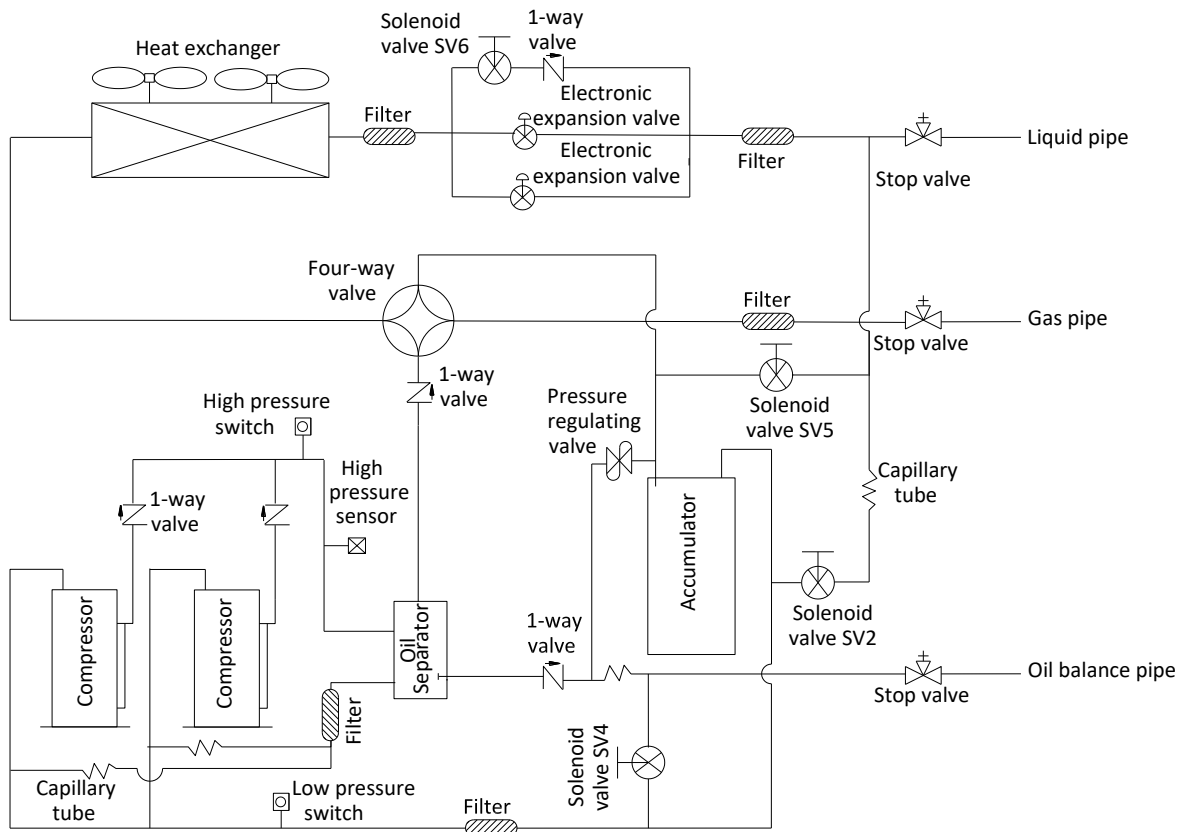

**Key components:**

- 1. Oil separator:**  
Separates oil from gas refrigerant pumped out of the compressor and quickly returns it to the compressor. Separation efficiency is up to 99%.
- 2. Accumulator:**  
Stores liquid refrigerant and oil to protect compressor from liquid hammering.
- 3. Electronic expansion valve (EXV):**  
Controls refrigerant flow and reduces refrigerant pressure.
- 4. Four-way valve:**  
Controls refrigerant flow direction. Closed in cooling mode and open in heating mode. When closed, the heat exchanger functions as a condenser; when open, the heat exchanger functions as an evaporator.
- 5. Solenoid valve SV2:**  
Protects the compressor. If compressor discharge temperature rises above 100°C, SV2 opens and sprays a small amount of liquid refrigerant to cool the compressor. SV2 closes again once the discharge temperature has fallen below 90°C.
- 6. Solenoid valve SV4:**  
Returns oil to the compressor. Opens once the compressor has run for 200 seconds and closes 600 seconds later and then opens for 3 minutes every 20 minutes.
- 7. Solenoid valve SV5:**  
Enables fast defrosting. During defrosting operation, opens to shorten the refrigerant flow cycle and quicken the defrosting process. Closed in cooling mode.
- 8. Solenoid valve SV6:**  
Allows refrigerant to bypass the expansion valves. Open in cooling mode when discharge temperature exceeds the limit. Closed in heating mode and standby.
- 9. High and low pressure switches:**  
Regulate system pressure. When system pressure rises above the upper limit or falls below the lower limit, the high or low pressure switches turn off, stopping the compressor. After 10 minutes, the compressor restarts.

# VMEX 460V 60Hz

## 5 Wiring Diagrams

VMEX008Q8A-D13V224/ VMEX009Q8A-D16V280/ VMEX010Q8A-D20V335

Figure 2-5.1: VMEX008(009,010)Q8A wiring diagram

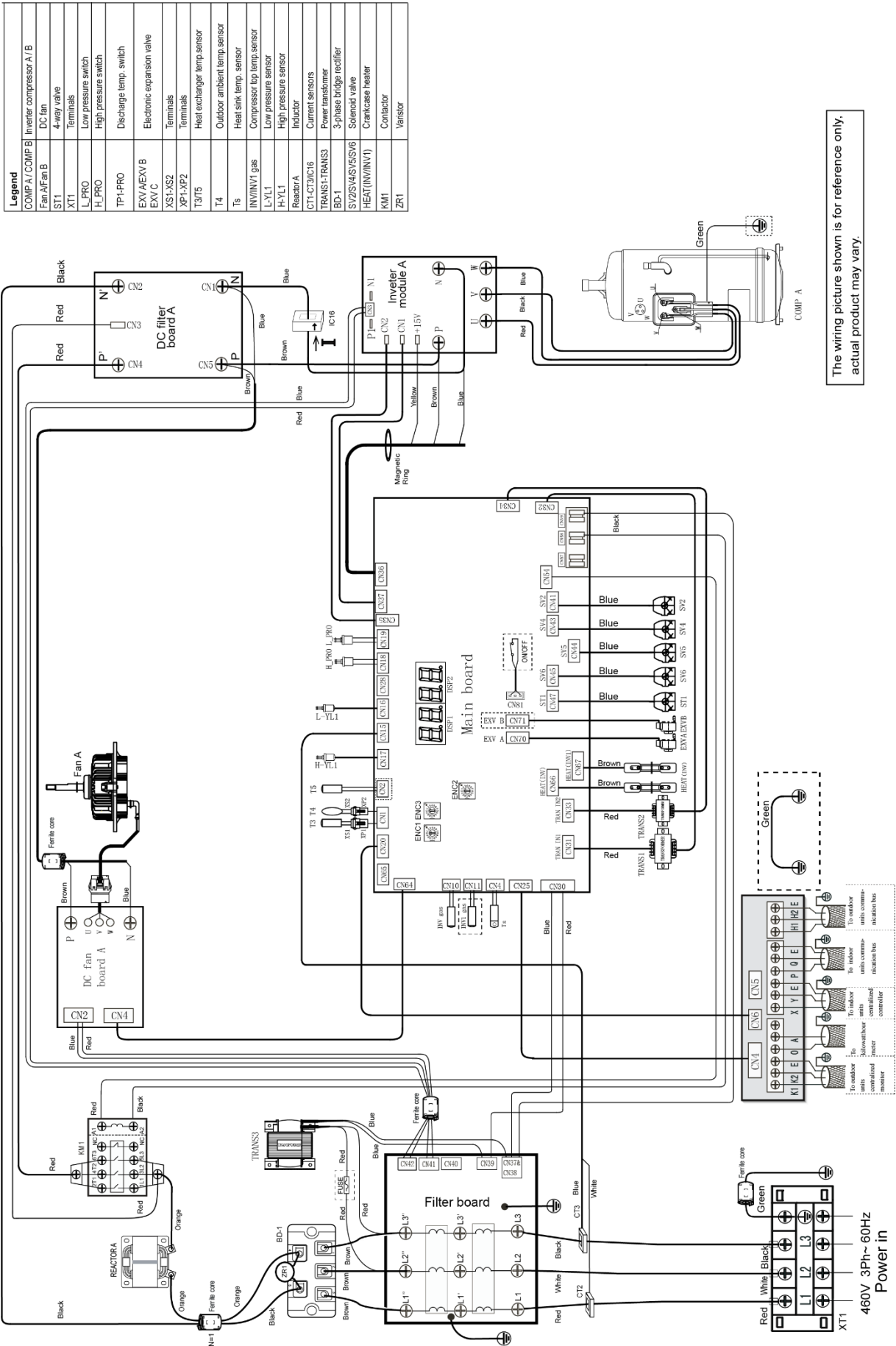
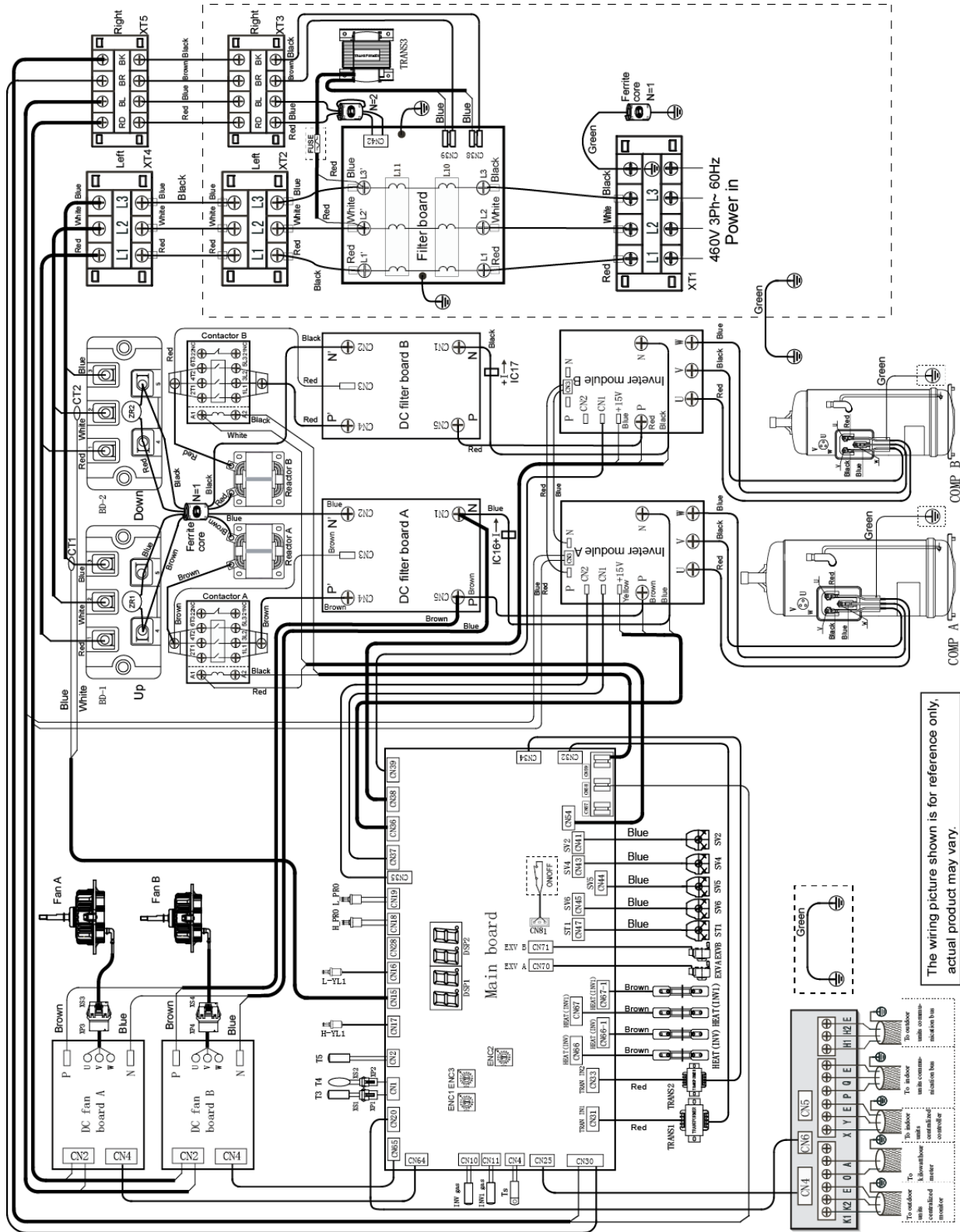



Figure 2-5.2: VMEX012(014,016,018,020)Q8A wiring diagram



Legend	
COMP A/COMP B	Inverter compressor A / B
Fan A/Fan B	DC fan
ST1	4-way valve
XT1-XT5	Terminals
L-PRO	Low pressure switch
H-PRO	High pressure switch
TP1-PRO	Discharge temp. switch
TP2-PRO	Electronic expansion valve
EXV A/EXV B	Terminals
EXV C	Terminals
XST1-XS4	Terminals
XP1-XP4	Terminals
T3/T5/T7/T7T	Heat exchanger temp. sensor
T4	Outdoor ambient temp. sensor
Ts	Heat sink temp. sensor
IN/IN1/ gas	Compressor top temp. sensor
L-YL1	Low pressure sensor
H-YL1	High pressure sensor
Reactor A/B	Inductor
CT1-CT3/CT16-17	Current sensors
TRANS1/TRANS3	Power transformer
BD-1/BD-2	3-phase bridge rectifier
SV2/SV5/SV5/SV6	Solenoid valve
HEAT (IN/IN1)	Crankcase heater

# VMEX 460V 60Hz

## 6 Electrical Characteristics

Table 2-6.1: Outdoor unit electrical characteristics

Model				Power supply <sup>1</sup>						Compressors		Outdoor fan motors			
Capacity	Modules			Hz	Volts	Min. volts	Max. volts	MCA <sup>2</sup>	TOCA <sup>3</sup>	MFA <sup>4</sup>	MSC <sup>5</sup>	RLA <sup>6</sup>	Rated motor output (kW)	FLA	
8HP	8HP			60	460	414	506	16.6	24.5	25	-	5.9	0.75	3.5	
10HP	10HP			60	460	414	506	17.8	24.5	25	-	6.8	0.75	3.5	
12HP	12HP			60	460	414	506	18.6	26.5	25	-	7.6	0.75	3.5	
14HP	14HP			60	460	414	506	24.1	32.6	30	-	5.1x2	0.75+0.75	1.4+1.2	
16HP	16HP			60	460	414	506	25.1	32.6	30	-	5.9x2	0.75+0.75	1.4+1.2	
18HP	18HP			60	460	414	506	27.5	38.0	40	-	8.5+5	0.75+0.75	1.6+1.4	
20HP	20HP			60	460	414	506	35.6	49.2	50	-	9.2x2	0.75+0.75	1.7+1.5	
22HP	22HP			60	460	414	506	37.3	49.2	50	-	9.7x2	0.75+0.75	1.7+1.5	
24HP	12HP	12HP		60	460	414	506	37.2	53	25+25	-	7.6x2	0.75x2	3.5x2	
26HP	10HP	16HP		60	460	414	506	42.9	57.1	25+30	-	6.8+5.9x2	0.75+(0.75+0.75)	3.5+(1.4+1.2)	
28HP	10HP	18HP		60	460	414	506	45.3	62.5	25+40	-	6.8+8.5+5	0.75+(0.75+0.75)	3.5+(1.6+1.4)	
30HP	10HP	20HP		60	460	414	506	53.4	73.7	25+50	-	6.8+9.2x2	0.75+(0.75+0.75)	3.5+(1.7+1.5)	
32HP	10HP	22HP		60	460	414	506	55.1	73.7	25+50	-	6.8+9.7x2	0.75+(0.75+0.75)	3.5+(1.7+1.5)	
34HP	12HP	22HP		60	460	414	506	55.9	75.7	25+50	-	7.6+9.7x2	0.75+(0.75+0.75)	3.5+(1.7+1.5)	
36HP	18HP	18HP		60	460	414	506	55.0	76.0	40+40	-	(8.5+5)x2	(0.75+0.75)x2	(1.6+1.4)x2	
38HP	16HP	22HP		60	460	414	506	62.4	81.8	30+50	-	5.9x2+9.7x2	(0.75+0.75)+(0.75+0.75)	(1.4+1.2)+(1.7+1.5)	
40HP	18HP	22HP		60	460	414	506	64.8	87.2	40+50	-	8.5+5+9.7x2	(0.75+0.75)+(0.75+0.75)	(1.6+1.4)+(1.7+1.5)	
42HP	20HP	22HP		60	460	414	506	72.9	98.4	50+50	-	9.2x2+9.7x2	(0.75+0.75)x2	(1.7+1.5)x2	
44HP	22HP	22HP		60	460	414	506	74.6	98.4	50+50	-	9.7x4	(0.75+0.75)x2	(1.7+1.5)x2	
46HP	12HP	12HP	22HP	60	460	414	506	74.5	102.2	25+25+50	-	7.6x2+9.7x2	0.75x2+(0.75+0.75)	3.5x2+(1.7+1.5)	
48HP	10HP	16HP	22HP	60	460	414	506	80.2	106.3	25+30+50	-	6.8+5.9x2+9.7x2	0.75+(0.75+0.75)+(0.75+0.75)	3.5+(1.4+1.2)+(1.7+1.5)	
50HP	10HP	18HP	22HP	60	460	414	506	82.6	111.7	25+40+50	-	6.8+8.5+5+9.7x2	0.75+(0.75+0.75)+(0.75+0.75)	3.5+(1.6+1.4)+(1.7+1.5)	
52HP	10HP	20HP	22HP	60	460	414	506	90.7	122.9	25+50+50	-	6.8+9.2x2+9.7x2	0.75+(0.75+0.75)x2	3.5+(1.7+1.5)x2	
54HP	10HP	22HP	22HP	60	460	414	506	92.4	122.9	25+50+50	-	6.8+9.7x4	0.75+(0.75+0.75)x2	3.5+(1.7+1.5)x2	
56HP	12HP	22HP	22HP	60	460	414	506	93.2	124.9	25+50+50	-	7.6+9.7x4	0.75+(0.75+0.75)x2	3.5+(1.7+1.5)x2	
58HP	18HP	18HP	22HP	60	460	414	506	92.3	125.2	40+40+50	-	(8.5+5)x2+9.7x2	(0.75+0.75)x2+(0.75+0.75)	(1.6+1.4)x2+(1.7+1.5)	
60HP	16HP	22HP	22HP	60	460	414	506	99.7	131	30+50+50	-	5.9x2+9.7x4	(0.75+0.75)+(0.75+0.75)x2	(1.4+1.2)+(1.7+1.5)x2	
62HP	18HP	22HP	22HP	60	460	414	506	102.1	136.4	40+50+50	-	8.5+5+9.7x4	(0.75+0.75)+(0.75+0.75)x2	(1.6+1.4)+(1.7+1.5)x2	
64HP	20HP	22HP	22HP	60	460	414	506	110.2	147.6	50+50+50	-	9.2x2+9.7x4	(0.75+0.75)x3	(1.7+1.5)x3	
66HP	22HP	22HP	22HP	60	460	414	506	111.9	147.6	50+50+50	-	9.7x6	(0.75+0.75)x3	(1.7+1.5)x3	
68HP	12HP	12HP	22HP	22HP	60	460	414	506	111.8	151.4	25+25+50+50	-	7.6x2+9.7x4	0.75x2+(0.75+0.75)x2	3.5x2+(1.7+1.5)x2
70HP	10HP	16HP	22HP	22HP	60	460	414	506	117.5	155.5	25+30+50+50	-	6.8+5.9x2+9.7x4	0.75+(0.75+0.75)+(0.75+0.75)x2	3.5+(1.4+1.2)+(1.7+1.5)x2
72HP	10HP	18HP	22HP	22HP	60	460	414	506	119.9	160.9	25+40+50+50	-	6.8+8.5+5+9.7x4	0.75+(0.75+0.75)+(0.75+0.75)x2	3.5+(1.6+1.4)+(1.7+1.5)x2
74HP	10HP	20HP	22HP	22HP	60	460	414	506	128	172.1	25+50+50+50	-	6.8+9.2x2+9.7x4	0.75+(0.75+0.75)x3	3.5+(1.7+1.5)x3
76HP	10HP	22HP	22HP	22HP	60	460	414	506	129.7	172.1	25+50+50+50	-	6.8+9.7x6	0.75+(0.75+0.75)x3	3.5+(1.7+1.5)x3
78HP	12HP	22HP	22HP	22HP	60	460	414	506	130.5	174.1	25+50+50+50	-	7.6+9.7x6	0.75+(0.75+0.75)x3	3.5+(1.7+1.5)x3
80HP	18HP	18HP	22HP	22HP	60	460	414	506	129.6	174.4	40+40+50+50	-	(8.5+5)x2+9.7x4	(0.75+0.75)x2+(0.75+0.75)x2	(1.6+1.4)x2+(1.7+1.5)x2
82HP	16HP	22HP	22HP	22HP	60	460	414	506	137	180.2	30+50+50+50	-	5.9x2+9.7x6	(0.75+0.75)+(0.75+0.75)x3	(1.4+1.2)+(1.7+1.5)x3
84HP	18HP	22HP	22HP	22HP	60	460	414	506	139.4	185.6	40+50+50+50	-	8.5+5+9.7x6	(0.75+0.75)+(0.75+0.75)x3	(1.6+1.4)+(1.7+1.5)x3
86HP	20HP	22HP	22HP	22HP	60	460	414	506	147.5	196.8	50+50+50+50	-	9.2x2+9.7x6	(0.75+0.75)x4	(1.7+1.5)x4
88HP	22HP	22HP	22HP	22HP	60	460	414	506	149.2	196.8	50+50+50+50	-	9.7x8	(0.75+0.75)x4	(1.7+1.5)x4

Abbreviations:

MCA: Minimum Circuit Amps  
 TOCA: Total Over-current  
 MFA: Maximum Fuse Amps  
 MSC: Maximum Starting Current (A)  
 RLA: Rated Load Amps  
 FLA: Full Load Amps

Notes:

- Units are suitable for use on electrical systems where voltage supplied to unit terminals is not below or above listed range limits. Maximum allowable voltage variation between phases is 2%.
- Select wire size based on the value of MCA.
- TOCA indicates the total overcurrent amps value of each OC set.
- MFA is used to select overcurrent circuit breakers and residual-current circuit breakers.
- MSC indicates the maximum current on compressor start-up in amps.
- RLA is based on the following conditions: indoor temperature 27°C DB, 19°C WB; outdoor temperature 35°C DB.

## 7 Functional Components and Safety Devices

Table 2-7.1: VMEX008(009,010)Q8A functional components and safety devices

Item		VMEX008Q8A-D13V224	VMEX009Q8A-D16V280	VMEX010Q8A-D20V335
Compressor	Discharge temperature switch	Off: 115 (±5) °C / On: 75 (±15) °C		
	Compressor top and discharge pipe temperature sensors	90°C = 5kΩ ± 3%		
	Crankcase heater	27.6W × 2		
Inverter module	Inverter module temperature sensor	90°C = 5kΩ ± 5%		
Fan motor	Safety thermostat	On	115°C	
		Off	-	
System	High pressure switch	Off: 4.4 (±0.1) MPa / On: 3.2 (±0.1) MPa		
	Low pressure switch	Off: 0.05 (±0.05) MPa / On: 0.15 (±0.05) MPa		
	High pressure sensor	Output voltage (V) = 1.1603 × P + 0.5 (where P is the discharge pressure in MPa)		
	Heat exchanger temperature sensor	25°C = 10kΩ		
	Outdoor ambient temperature sensor	25°C = 10kΩ		

Table 2-7.2: VMEX012(014,016)Q8A functional components and safety devices

Item		VMEX012Q8A-D23V400	VMEX014Q8A-D26V450	VMEX016Q8A-D29V500
Compressor	Discharge temperature switch	Off: 115 (±5) °C / On: 75 (±15) °C		
	Compressor top temperature sensors	90°C = 5kΩ ± 3%		
	Crankcase heater	27.6W × 2 × 2		
Inverter module	Inverter module temperature sensor	90°C = 5kΩ ± 5%		
Fan motor	Safety thermostat	On	115°C	
		Off	-	
System	High pressure switch	Off: 4.4 (±0.1) MPa / On: 3.2 (±0.1) MPa		
	Low pressure switch	Off: 0.05 (±0.05) MPa / On: 0.15 (±0.05) MPa		
	High pressure sensor	Output voltage (V) = 1.1603 × P + 0.5 (where P is the discharge pressure in MPa)		
	Heat exchanger temperature sensor	25°C = 10kΩ		
	Outdoor ambient temperature sensor	25°C = 10kΩ		

Table 2-7.3: VMEX018(020)Q8A functional components and safety devices

Item		VMEX018Q8A-D33V560	VMEX020Q8A-D36V615
Compressor	Discharge temperature switch	Off: 115 (±5) °C / On: 75 (±15) °C	
	Compressor top temperature sensors	90°C = 5kΩ ± 3%	
	Crankcase heater	27.6W × 2 × 2	
Inverter module	Inverter module temperature sensor	90°C = 5kΩ ± 5%	
Fan motor	Safety thermostat	On	115°C
		Off	-
System	High pressure switch	Off: 4.4 (±0.1) MPa / On: 3.2 (±0.1) MPa	
	Low pressure switch	Off: 0.05 (±0.05) MPa / On: 0.15 (±0.05) MPa	
	High pressure sensor	Output voltage (V) = 1.1603 × P + 0.5 (where P is the discharge pressure in MPa)	
	Heat exchanger temperature sensor	25°C = 10kΩ	
	Outdoor ambient temperature sensor	25°C = 10kΩ	

# VMEX 460V 60Hz

## 8 Capacity Tables

### 8.1 Cooling Capacity Tables

Table 2-8.1: VMEX008Q8A-D13V224 cooling capacity

CR	Outdoor air temp. (°C DB)	Indoor air temp. (°C DB / °C WB)													
		20.8 / 14.0		23.3 / 16.0		25.8 / 18.0		27.0 / 19.0		28.2 / 20.0		30.7 / 22.0		32.0 / 24.0	
		TC	PI	TC	PI	TC	PI	TC	PI	TC	PI	TC	PI	TC	PI
		kW	kW	kW	kW	kW	kW	kW	kW	kW	kW	kW	kW	kW	kW
130%	-5	22.1	2.19	26.4	2.67	30.6	2.87	31.8	2.98	33.3	3.07	34.1	3.34	35.0	3.36
	-2	22.1	2.19	26.4	2.73	30.6	2.87	31.8	3.00	33.3	3.07	34.1	3.38	35.0	3.39
	0	22.1	2.23	26.4	2.77	30.6	2.97	31.8	3.17	33.3	3.25	34.1	3.42	35.0	3.44
	2	22.1	2.27	26.4	2.78	30.6	3.07	31.8	3.34	33.3	3.28	34.1	3.44	35.0	3.49
	4	22.1	2.32	26.4	2.83	30.6	3.18	31.8	3.36	33.3	3.33	34.1	3.50	35.0	3.55
	6	22.1	2.36	26.4	2.89	30.6	3.30	31.8	3.39	32.9	3.43	33.7	3.55	34.6	3.58
	8	22.1	2.42	26.4	2.96	30.6	3.46	31.8	3.55	32.5	3.54	33.3	3.56	34.1	3.61
	10	22.1	2.47	26.4	3.02	30.6	3.59	31.8	3.67	32.1	3.61	32.9	3.62	33.7	3.72
	12	22.1	2.51	26.4	3.08	30.6	3.66	31.3	3.72	31.8	3.66	32.5	3.67	33.3	3.74
	14	22.1	2.56	26.4	3.14	30.5	3.72	31.0	3.78	31.3	3.72	32.1	3.73	32.9	3.83
	16	22.1	2.61	26.4	3.20	30.1	3.77	30.5	3.83	30.9	3.83	31.7	3.78	32.5	3.89
	18	22.1	2.66	26.4	3.27	29.7	3.83	30.1	3.85	30.5	3.87	31.3	3.91	32.1	3.94
	20	22.1	2.72	26.4	3.47	29.2	4.02	29.7	4.04	30.1	4.06	30.9	4.10	31.7	4.14
	21	22.1	2.79	26.4	3.60	29.1	4.11	29.5	4.13	29.9	4.15	30.7	4.20	31.5	4.23
	23	22.1	2.99	26.4	3.86	28.7	4.30	29.1	4.32	29.4	4.34	30.2	4.38	31.0	4.43
	25	22.1	3.19	26.4	4.13	28.3	4.49	28.6	4.51	29.1	4.54	29.9	4.58	30.7	4.62
	27	22.1	3.41	26.4	4.42	27.9	4.67	28.3	4.70	28.6	4.72	29.4	4.78	30.2	4.83
	29	22.1	3.64	26.4	4.72	27.4	4.86	27.8	4.89	28.3	4.92	29.1	4.97	29.9	5.02
	31	22.1	3.89	26.3	5.00	27.0	5.06	27.4	5.09	27.8	5.11	28.6	5.17	29.4	5.22
	33	22.1	4.14	25.8	5.19	26.6	5.24	27.0	5.27	27.4	5.30	28.3	5.36	29.0	5.42
35	22.1	4.41	25.4	5.37	26.2	5.44	26.6	5.47	27.0	5.50	27.8	5.56	28.6	5.62	
37	22.1	4.70	25.0	5.57	25.8	5.64	26.2	5.66	26.6	5.70	27.4	5.77	28.2	5.83	
39	22.1	5.00	24.6	5.63	25.4	5.82	25.8	5.86	26.2	5.89	27.0	5.96	27.8	6.03	
41	22.1	5.26	24.3	5.68	25.1	5.88	25.6	5.91	25.9	5.95	26.7	5.97	26.7	6.09	
43	22.1	5.40	24.1	5.71	25.0	5.89	25.4	5.94	25.7	5.96	26.2	5.98	26.4	6.10	
45	22.1	5.66	24.0	5.76	24.7	5.95	25.2	5.98	25.3	5.99	25.5	6.00	25.9	6.22	
48	22.1	5.86	23.9	5.95	24.3	6.00	24.8	6.03	25.0	6.05	24.9	6.11	25.3	6.24	
120%	-5	20.4	2.12	24.3	2.56	28.3	3.03	30.2	3.31	31.7	3.45	32.4	3.56	33.1	3.65
	-2	20.4	2.14	24.3	2.59	28.3	3.06	30.2	3.32	31.7	3.49	32.4	3.59	33.1	3.66
	0	20.4	2.16	24.3	2.61	28.3	3.10	30.2	3.33	31.7	3.52	32.4	3.61	33.1	3.67
	2	20.4	2.16	24.3	2.63	28.3	3.12	30.2	3.36	31.7	3.53	32.4	3.63	33.1	3.68
	4	20.4	2.18	24.3	2.67	28.3	3.16	30.2	3.40	31.7	3.58	32.4	3.64	33.1	3.69
	6	20.4	2.21	24.3	2.69	28.3	3.20	30.2	3.43	31.7	3.62	32.4	3.67	33.1	3.70
	8	20.4	2.23	24.3	2.72	28.3	3.24	30.2	3.48	31.7	3.65	32.4	3.68	33.1	3.72
	10	20.4	2.25	24.3	2.75	28.3	3.27	30.2	3.54	31.7	3.66	32.4	3.69	33.1	3.73
	12	20.4	2.30	24.3	2.80	28.3	3.34	30.2	3.60	31.2	3.67	31.9	3.67	32.7	3.76
	14	20.4	2.34	24.3	2.86	28.3	3.40	30.2	3.68	30.8	3.69	31.6	3.73	32.3	3.80
	16	20.4	2.38	24.3	2.92	28.3	3.47	30.1	3.74	30.4	3.75	31.1	3.79	31.9	3.86
	18	20.4	2.43	24.3	2.98	28.3	3.58	29.6	3.83	30.0	3.84	30.7	3.88	31.5	3.92
	20	20.4	2.48	24.3	3.09	28.3	3.86	29.2	4.02	29.6	4.03	30.3	4.07	31.1	4.10
	21	20.4	2.50	24.3	3.20	28.3	3.99	29.0	4.11	29.3	4.12	30.2	4.16	30.9	4.20
	23	20.4	2.67	24.3	3.43	28.3	4.28	28.6	4.29	29.0	4.31	29.7	4.36	30.4	4.39
	25	20.4	2.85	24.3	3.67	27.8	4.46	28.2	4.48	28.5	4.50	29.3	4.54	30.1	4.59
	27	20.4	3.05	24.3	3.92	27.4	4.65	27.8	4.67	28.2	4.70	28.9	4.74	29.6	4.78
	29	20.4	3.25	24.3	4.19	27.0	4.83	27.4	4.86	27.7	4.88	28.4	4.93	29.2	4.98
	31	20.4	3.47	24.3	4.47	26.5	5.03	27.0	5.05	27.4	5.08	28.1	5.13	28.8	5.18
	33	20.4	3.69	24.3	4.77	26.2	5.22	26.5	5.24	26.9	5.27	27.6	5.32	28.3	5.37
35	20.4	3.93	24.3	5.09	25.7	5.40	26.1	5.43	26.5	5.46	27.3	5.52	28.0	5.58	
37	20.4	4.18	24.3	5.42	25.4	5.60	25.7	5.63	26.1	5.66	26.8	5.71	27.5	5.78	
39	20.4	4.45	24.2	5.72	24.9	5.79	25.3	5.82	25.7	5.85	26.5	5.92	27.2	5.97	
41	20.4	4.57	24.0	5.76	24.7	5.83	25.1	5.86	25.5	5.89	26.3	5.93	26.4	6.02	
43	20.4	4.64	23.9	5.80	24.5	5.86	24.9	5.89	25.3	5.91	25.8	5.95	26.0	6.14	
45	20.4	4.69	23.8	5.86	24.3	5.92	24.6	5.94	25.0	5.96	25.3	5.97	25.7	6.27	
48	20.4	4.73	23.6	5.92	24.0	5.97	24.2	5.98	24.8	6.01	24.9	5.99	25.4	6.35	

Abbreviations:

CR: Combination ratio

TC: Total capacity (kW)

PI: Power input (compressor + outdoor fan motor) (kW)

Notes:

1. Shaded cells indicate rating condition.

Table continued on next page ...

Table 2-8.1: VMEX008Q8A-D13V224 cooling capacity (continued)

CR	Outdoor air temp. (°C DB)	Indoor air temp. (°C DB / °C WB)													
		20.8 / 14.0		23.3 / 16.0		25.8 / 18.0		27.0 / 19.0		28.2 / 20.0		30.7 / 22.0		32.0 / 24.0	
		TC	PI	TC	PI	TC	PI	TC	PI	TC	PI	TC	PI	TC	PI
		kW	kW	kW	kW	kW	kW	kW	kW	kW	kW	kW	kW	kW	kW
110%	-5	18.7	1.85	22.3	2.30	25.9	2.75	27.7	2.95	29.5	3.17	31.8	3.29	32.5	3.39
	-2	18.7	1.88	22.3	2.33	25.9	2.77	27.7	2.98	29.5	3.20	31.8	3.33	32.5	3.41
	0	18.7	1.90	22.3	2.34	25.9	2.79	27.7	3.00	29.5	3.23	31.8	3.36	32.5	3.45
	2	18.7	1.94	22.3	2.37	25.9	2.83	27.7	3.03	29.5	3.27	31.8	3.41	32.5	3.50
	4	18.7	1.98	22.3	2.39	25.9	2.86	27.7	3.07	29.5	3.32	31.8	3.45	32.5	3.53
	6	18.7	2.00	22.3	2.42	25.9	2.89	27.7	3.11	29.5	3.35	31.8	3.49	32.5	3.58
	8	18.7	2.02	22.3	2.46	25.9	2.92	27.7	3.15	29.5	3.39	31.8	3.51	32.5	3.62
	10	18.7	2.04	22.3	2.49	25.9	2.96	27.7	3.20	29.5	3.45	31.8	3.54	32.5	3.65
	12	18.7	2.09	22.3	2.54	25.9	3.02	27.7	3.27	29.5	3.51	31.4	3.59	32.0	3.70
	14	18.7	2.12	22.3	2.59	25.9	3.08	27.7	3.32	29.5	3.58	31.0	3.62	31.7	3.73
	16	18.7	2.16	22.3	2.64	25.9	3.14	27.7	3.39	29.5	3.65	30.6	3.66	31.2	3.77
	18	18.7	2.20	22.3	2.69	25.9	3.20	27.7	3.48	29.5	3.82	30.2	3.85	30.9	3.89
	20	18.7	2.25	22.3	2.75	25.9	3.39	27.7	3.74	29.1	4.01	29.8	4.04	30.4	4.07
	21	18.7	2.27	22.3	2.82	25.9	3.51	27.7	3.88	28.9	4.10	29.5	4.13	30.2	4.17
	23	18.7	2.38	22.3	3.03	25.9	3.76	27.7	4.16	28.4	4.28	29.2	4.33	29.8	4.36
	25	18.7	2.54	22.3	3.24	25.9	4.02	27.7	4.46	28.1	4.47	28.7	4.52	29.4	4.55
	27	18.7	2.70	22.3	3.46	25.9	4.31	27.3	4.65	27.6	4.66	28.4	4.70	29.0	4.75
	29	18.7	2.88	22.3	3.69	25.9	4.60	26.9	4.83	27.3	4.85	27.9	4.90	28.6	4.94
	31	18.7	3.07	22.3	3.94	25.9	4.91	26.5	5.02	26.8	5.04	27.5	5.09	28.2	5.14
	33	18.7	3.27	22.3	4.20	25.7	5.18	26.1	5.21	26.5	5.23	27.1	5.28	27.8	5.33
35	18.7	3.47	22.3	4.47	25.3	5.37	25.7	5.40	26.0	5.43	26.6	5.48	27.4	5.53	
37	18.7	3.70	22.3	4.76	24.9	5.56	25.3	5.58	25.6	5.61	26.3	5.67	26.9	5.72	
39	18.7	3.93	22.3	5.07	24.5	5.75	24.8	5.78	25.2	5.81	25.8	5.87	26.6	5.92	
41	18.7	3.97	22.3	5.11	24.3	5.79	24.6	5.82	25.0	5.85	25.5	5.91	25.8	5.96	
43	18.7	4.01	22.3	5.18	24.1	5.83	24.5	5.86	24.8	5.89	25.3	5.93	25.4	6.09	
45	18.7	4.14	22.3	5.21	23.9	5.89	24.2	5.93	24.6	5.94	25.0	6.09	25.1	6.23	
48	18.7	4.29	22.3	5.65	23.5	5.92	23.8	5.97	24.3	6.01	24.6	6.11	24.8	6.29	
100%	-5	17.0	1.68	20.3	2.03	23.6	2.41	25.2	2.58	26.8	2.80	30.1	3.19	31.9	3.33
	-2	17.0	1.70	20.3	2.05	23.6	2.44	25.2	2.63	26.8	2.84	30.1	3.23	31.9	3.36
	0	17.0	1.72	20.3	2.07	23.6	2.47	25.2	2.66	26.8	2.87	30.1	3.29	31.9	3.39
	2	17.0	1.75	20.3	2.10	23.6	2.49	25.2	2.70	26.8	2.90	30.1	3.33	31.9	3.45
	4	17.0	1.77	20.3	2.12	23.6	2.53	25.2	2.74	26.8	2.94	30.1	3.37	31.9	3.48
	6	17.0	1.79	20.3	2.17	23.6	2.56	25.2	2.79	26.8	2.98	30.1	3.41	31.9	3.54
	8	17.0	1.83	20.3	2.20	23.6	2.61	25.2	2.82	26.8	3.03	30.1	3.47	31.9	3.60
	10	17.0	1.85	20.3	2.24	23.6	2.65	25.2	2.87	26.8	3.08	30.1	3.53	31.9	3.65
	12	17.0	1.88	20.3	2.28	23.6	2.70	25.2	2.92	26.8	3.14	30.1	3.59	31.4	3.68
	14	17.0	1.91	20.3	2.33	23.6	2.75	25.2	2.98	26.8	3.20	30.1	3.66	31.0	3.72
	16	17.0	1.95	20.3	2.37	23.6	2.81	25.2	3.03	26.8	3.27	30.0	3.71	30.6	3.76
	18	17.0	1.99	20.3	2.41	23.6	2.86	25.2	3.09	26.8	3.33	29.6	3.83	30.2	3.86
	20	17.0	2.02	20.3	2.46	23.6	2.95	25.2	3.25	26.8	3.57	29.2	4.01	29.8	4.05
	21	17.0	2.04	20.3	2.48	23.6	3.06	25.2	3.37	26.8	3.69	29.0	4.10	29.6	4.14
	23	17.0	2.09	20.3	2.65	23.6	3.27	25.2	3.60	26.8	3.96	28.6	4.29	29.2	4.33
	25	17.0	2.23	20.3	2.83	23.6	3.50	25.2	3.86	26.8	4.24	28.2	4.48	28.8	4.51
	27	17.0	2.38	20.3	3.02	23.6	3.74	25.2	4.13	26.8	4.54	27.7	4.67	28.4	4.71
	29	17.0	2.54	20.3	3.22	23.6	3.99	25.2	4.41	26.7	4.82	27.4	4.86	28.0	4.90
	31	17.0	2.70	20.3	3.44	23.6	4.26	25.2	4.71	26.4	5.01	26.9	5.05	27.5	5.09
	33	17.0	2.87	20.3	3.66	23.6	4.54	25.2	5.03	25.9	5.19	26.6	5.24	27.2	5.29
35	17.0	3.05	20.3	3.89	23.6	4.85	<b>25.2</b>	<b>5.36</b>	25.5	5.38	26.1	5.43	26.7	5.48	
37	17.0	3.24	20.3	4.15	23.6	5.16	24.7	5.55	25.1	5.58	25.7	5.63	26.3	5.67	
39	17.0	3.45	20.3	4.41	23.6	5.50	24.4	5.74	24.7	5.76	25.3	5.82	25.9	5.87	
41	17.0	3.61	20.3	4.57	23.6	5.70	24.0	5.78	24.5	5.85	24.9	5.95	25.5	5.99	
43	17.0	3.77	20.3	4.73	23.6	5.80	23.6	5.84	24.3	5.91	25.0	5.99	25.1	6.06	
45	17.0	3.98	20.3	4.94	23.6	5.90	23.1	5.92	24.2	6.02	24.8	6.08	24.6	6.14	
48	17.0	4.16	20.3	5.12	23.6	5.91	22.2	5.99	24.1	6.12	23.3	6.15	24.0	6.20	

Abbreviations:

CR: Combination ratio

TC: Total capacity (kW)

PI: Power input (compressor + outdoor fan motor) (kW)

Notes:

1. Shaded cells indicate rating condition.

Table continued on next page ...

# VMEX 460V 60Hz

Table 2-8.1: VMEX008Q8A-D13V224 cooling capacity (continued)

CR	Outdoor air temp. (°C DB)	Indoor air temp. (°C DB / °C WB)													
		20.8 / 14.0		23.3 / 16.0		25.8 / 18.0		27.0 / 19.0		28.2 / 20.0		30.7 / 22.0		32.0 / 24.0	
		TC kW	PI kW	TC kW	PI kW	TC kW	PI kW	TC kW	PI kW	TC kW	PI kW	TC kW	PI kW	TC kW	PI kW
90%	-5	15.3	1.49	18.3	1.79	21.2	2.11	22.7	2.30	24.1	2.45	27.1	2.81	30.1	3.22
	-2	15.3	1.50	18.3	1.80	21.2	2.13	22.7	2.33	24.1	2.48	27.1	2.84	30.1	3.25
	0	15.3	1.53	18.3	1.83	21.2	2.17	22.7	2.36	24.1	2.51	27.1	2.87	30.1	3.28
	2	15.3	1.55	18.3	1.85	21.2	2.19	22.7	2.40	24.1	2.55	27.1	2.93	30.1	3.32
	4	15.3	1.57	18.3	1.88	21.2	2.23	22.7	2.43	24.1	2.58	27.1	2.98	30.1	3.37
	6	15.3	1.59	18.3	1.91	21.2	2.27	22.7	2.47	24.1	2.62	27.1	3.02	30.1	3.43
	8	15.3	1.62	18.3	1.95	21.2	2.31	22.7	2.51	24.1	2.67	27.1	3.08	30.1	3.46
	10	15.3	1.65	18.3	1.99	21.2	2.35	22.7	2.54	24.1	2.73	27.1	3.12	30.1	3.52
	12	15.3	1.68	18.3	2.03	21.2	2.40	22.7	2.59	24.1	2.78	27.1	3.18	30.1	3.58
	14	15.3	1.71	18.3	2.07	21.2	2.44	22.7	2.64	24.1	2.83	27.1	3.24	30.1	3.65
	16	15.3	1.74	18.3	2.10	21.2	2.49	22.7	2.69	24.1	2.89	27.1	3.30	30.0	3.71
	18	15.3	1.77	18.3	2.15	21.2	2.54	22.7	2.74	24.1	2.95	27.1	3.37	29.6	3.83
	20	15.3	1.81	18.3	2.19	21.2	2.59	22.7	2.80	24.1	3.06	27.1	3.62	29.2	4.01
	21	15.3	1.82	18.3	2.21	21.2	2.63	22.7	2.89	24.1	3.16	27.1	3.75	29.0	4.10
	23	15.3	1.86	18.3	2.30	21.2	2.82	22.7	3.10	24.1	3.39	27.1	4.02	28.5	4.29
	25	15.3	1.96	18.3	2.46	21.2	3.01	22.7	3.32	24.1	3.63	27.1	4.31	28.2	4.48
	27	15.3	2.08	18.3	2.61	21.2	3.21	22.7	3.54	24.1	3.88	27.1	4.61	27.7	4.67
	29	15.3	2.22	18.3	2.79	21.2	3.43	22.7	3.78	24.1	4.15	26.8	4.82	27.4	4.85
	31	15.3	2.35	18.3	2.97	21.2	3.65	22.7	4.03	24.1	4.42	26.4	5.01	26.9	5.05
	33	15.3	2.50	18.3	3.16	21.2	3.90	22.7	4.30	24.1	4.72	26.0	5.20	26.5	5.24
35	15.3	2.66	18.3	3.36	21.2	4.15	22.7	4.58	24.1	5.03	25.6	5.39	26.1	5.43	
37	15.3	2.82	18.3	3.57	21.2	4.42	22.7	4.88	24.1	5.36	25.1	5.58	25.7	5.62	
39	15.3	2.99	18.3	3.80	21.2	4.70	22.7	5.19	24.1	5.71	24.8	5.77	25.3	5.81	
41	15.3	3.09	18.3	3.97	21.2	4.87	22.7	5.33	24.1	5.74	24.6	5.92	25.1	5.95	
43	15.3	3.24	18.3	4.14	21.2	5.05	22.7	5.47	24.1	5.86	24.5	6.00	24.9	6.04	
45	15.3	3.45	18.3	4.35	21.2	5.25	22.7	5.65	24.1	6.03	24.3	6.06	24.5	6.13	
48	15.3	3.64	18.3	4.55	21.2	5.45	22.7	5.72	24.1	6.08	24.1	6.14	23.9	6.21	
80%	-5	13.6	1.31	16.2	1.55	18.8	1.84	20.2	1.95	21.5	2.10	24.1	2.43	26.7	2.77
	-2	13.6	1.33	16.2	1.57	18.8	1.85	20.2	1.98	21.5	2.12	24.1	2.45	26.7	2.80
	0	13.6	1.35	16.2	1.59	18.8	1.87	20.2	2.01	21.5	2.16	24.1	2.49	26.7	2.84
	2	13.6	1.38	16.2	1.61	18.8	1.90	20.2	2.04	21.5	2.20	24.1	2.54	26.7	2.89
	4	13.6	1.40	16.2	1.64	18.8	1.94	20.2	2.09	21.5	2.24	24.1	2.58	26.7	2.93
	6	13.6	1.43	16.2	1.68	18.8	1.97	20.2	2.14	21.5	2.28	24.1	2.62	26.7	2.98
	8	13.6	1.45	16.2	1.72	18.8	2.01	20.2	2.17	21.5	2.33	24.1	2.66	26.7	3.04
	10	13.6	1.47	16.2	1.76	18.8	2.07	20.2	2.23	21.5	2.38	24.1	2.72	26.7	3.07
	12	13.6	1.49	16.2	1.78	18.8	2.10	20.2	2.27	21.5	2.43	24.1	2.77	26.7	3.13
	14	13.6	1.52	16.2	1.82	18.8	2.14	20.2	2.30	21.5	2.48	24.1	2.82	26.7	3.19
	16	13.6	1.54	16.2	1.85	18.8	2.18	20.2	2.35	21.5	2.52	24.1	2.88	26.7	3.24
	18	13.6	1.57	16.2	1.89	18.8	2.23	20.2	2.40	21.5	2.57	24.1	2.94	26.7	3.31
	20	13.6	1.60	16.2	1.92	18.8	2.27	20.2	2.44	21.5	2.62	24.1	3.05	26.7	3.54
	21	13.6	1.61	16.2	1.94	18.8	2.29	20.2	2.47	21.5	2.68	24.1	3.16	26.7	3.67
	23	13.6	1.64	16.2	1.98	18.8	2.40	20.2	2.63	21.5	2.87	24.1	3.38	26.7	3.94
	25	13.6	1.69	16.2	2.10	18.8	2.56	20.2	2.81	21.5	3.06	24.1	3.62	26.7	4.21
	27	13.6	1.80	16.2	2.24	18.8	2.73	20.2	3.00	21.5	3.27	24.1	3.86	26.7	4.51
	29	13.6	1.91	16.2	2.38	18.8	2.91	20.2	3.19	21.5	3.50	24.1	4.12	26.7	4.82
	31	13.6	2.03	16.2	2.54	18.8	3.10	20.2	3.40	21.5	3.73	24.1	4.41	26.3	5.01
	33	13.6	2.16	16.2	2.69	18.8	3.30	20.2	3.63	21.5	3.97	24.1	4.70	25.9	5.19
35	13.6	2.29	16.2	2.87	18.8	3.51	20.2	3.86	21.5	4.23	24.1	5.01	25.5	5.38	
37	13.6	2.43	16.2	3.04	18.8	3.73	20.2	4.11	21.5	4.50	24.1	5.34	25.1	5.57	
39	13.6	2.57	16.2	3.24	18.8	3.97	20.2	4.37	21.5	4.79	24.1	5.69	24.7	5.76	
41	13.6	2.63	16.2	3.27	18.8	4.03	20.2	4.49	21.5	4.88	24.1	5.83	24.5	5.87	
43	13.6	2.71	16.2	3.30	18.8	4.09	20.2	4.56	21.5	4.94	24.1	5.90	24.4	5.93	
45	13.6	2.78	16.2	3.34	18.8	4.17	20.2	4.66	21.5	5.03	24.1	5.96	24.1	6.03	
48	13.6	2.88	16.2	3.36	18.8	4.23	20.2	4.72	21.5	5.07	24.1	6.02	23.9	6.11	

Abbreviations:

CR: Combination ratio

TC: Total capacity (kW)

PI: Power input (compressor + outdoor fan motor) (kW)

Notes:

1. Shaded cells indicate rating condition.

Table continued on next page ...

Table 2-8.1: VMEX008Q8A-D13V224 cooling capacity (continued)

CR	Outdoor air temp. (°C DB)	Indoor air temp. (°C DB / °C WB)													
		20.8 / 14.0		23.3 / 16.0		25.8 / 18.0		27.0 / 19.0		28.2 / 20.0		30.7 / 22.0		32.0 / 24.0	
		TC kW	PI kW	TC kW	PI kW	TC kW	PI kW	TC kW	PI kW	TC kW	PI kW	TC kW	PI kW	TC kW	PI kW
70%	-5	11.9	1.17	14.2	1.37	16.5	1.56	17.6	1.67	18.8	1.78	21.1	2.04	23.4	2.34
	-2	11.9	1.18	14.2	1.38	16.5	1.57	17.6	1.70	18.8	1.81	21.1	2.07	23.4	2.37
	0	11.9	1.19	14.2	1.40	16.5	1.60	17.6	1.73	18.8	1.84	21.1	2.11	23.4	2.41
	2	11.9	1.19	14.2	1.40	16.5	1.62	17.6	1.76	18.8	1.88	21.1	2.16	23.4	2.44
	4	11.9	1.21	14.2	1.44	16.5	1.66	17.6	1.80	18.8	1.92	21.1	2.19	23.4	2.50
	6	11.9	1.23	14.2	1.47	16.5	1.70	17.6	1.85	18.8	1.96	21.1	2.23	23.4	2.55
	8	11.9	1.25	14.2	1.51	16.5	1.74	17.6	1.88	18.8	2.00	21.1	2.29	23.4	2.60
	10	11.9	1.28	14.2	1.53	16.5	1.78	17.6	1.92	18.8	2.06	21.1	2.34	23.4	2.63
	12	11.9	1.31	14.2	1.55	16.5	1.82	17.6	1.96	18.8	2.10	21.1	2.38	23.4	2.68
	14	11.9	1.33	14.2	1.58	16.5	1.85	17.6	1.99	18.8	2.13	21.1	2.43	23.4	2.73
	16	11.9	1.35	14.2	1.61	16.5	1.89	17.6	2.03	18.8	2.17	21.1	2.47	23.4	2.78
	18	11.9	1.37	14.2	1.64	16.5	1.92	17.6	2.07	18.8	2.21	21.1	2.52	23.4	2.84
	20	11.9	1.39	14.2	1.67	16.5	1.96	17.6	2.10	18.8	2.25	21.1	2.57	23.4	2.92
	21	11.9	1.41	14.2	1.68	16.5	1.97	17.6	2.12	18.8	2.28	21.1	2.61	23.4	3.02
	23	11.9	1.43	14.2	1.71	16.5	2.02	17.6	2.20	18.8	2.39	21.1	2.80	23.4	3.24
	25	11.9	1.46	14.2	1.78	16.5	2.15	17.6	2.35	18.8	2.55	21.1	2.99	23.4	3.46
	27	11.9	1.55	14.2	1.90	16.5	2.29	17.6	2.50	18.8	2.72	21.1	3.19	23.4	3.70
	29	11.9	1.64	14.2	2.02	16.5	2.43	17.6	2.67	18.8	2.90	21.1	3.40	23.4	3.95
	31	11.9	1.73	14.2	2.14	16.5	2.59	17.6	2.83	18.8	3.08	21.1	3.63	23.4	4.21
	33	11.9	1.84	14.2	2.28	16.5	2.76	17.6	3.01	18.8	3.29	21.1	3.86	23.4	4.49
35	11.9	1.95	14.2	2.41	16.5	2.93	17.6	3.21	18.8	3.50	21.1	4.12	23.4	4.79	
37	11.9	2.06	14.2	2.56	16.5	3.11	17.6	3.40	18.8	3.72	21.1	4.38	23.4	5.10	
39	11.9	2.18	14.2	2.71	16.5	3.30	17.6	3.62	18.8	3.95	21.1	4.66	23.4	5.43	
41	11.9	2.28	14.2	2.81	16.5	3.40	17.6	3.74	18.8	4.07	21.1	4.85	23.4	5.67	
43	11.9	2.46	14.2	3.00	16.5	3.54	17.6	3.94	18.8	4.19	21.1	5.03	23.4	5.85	
45	11.9	2.52	14.2	3.06	16.5	3.61	17.6	4.00	18.8	4.40	21.1	5.30	23.4	6.07	
48	11.9	2.58	14.2	3.09	16.5	3.65	17.6	4.07	18.8	4.52	21.1	5.54	23.4	6.22	
60%	-5	10.2	1.00	12.2	1.16	14.1	1.35	15.1	1.44	16.1	1.55	18.1	1.74	20.1	2.00
	-2	10.2	1.00	12.2	1.18	14.1	1.37	15.1	1.46	16.1	1.57	18.1	1.77	20.1	2.01
	0	10.2	1.02	12.2	1.19	14.1	1.39	15.1	1.48	16.1	1.59	18.1	1.80	20.1	2.04
	2	10.2	1.04	12.2	1.22	14.1	1.42	15.1	1.51	16.1	1.62	18.1	1.83	20.1	2.07
	4	10.2	1.07	12.2	1.24	14.1	1.45	15.1	1.52	16.1	1.64	18.1	1.86	20.1	2.09
	6	10.2	1.08	12.2	1.27	14.1	1.47	15.1	1.56	16.1	1.67	18.1	1.90	20.1	2.14
	8	10.2	1.10	12.2	1.29	14.1	1.50	15.1	1.59	16.1	1.71	18.1	1.93	20.1	2.18
	10	10.2	1.12	12.2	1.31	14.1	1.52	15.1	1.63	16.1	1.74	18.1	1.97	20.1	2.21
	12	10.2	1.14	12.2	1.34	14.1	1.55	15.1	1.66	16.1	1.77	18.1	2.01	20.1	2.25
	14	10.2	1.16	12.2	1.36	14.1	1.57	15.1	1.69	16.1	1.81	18.1	2.04	20.1	2.29
	16	10.2	1.17	12.2	1.38	14.1	1.60	15.1	1.72	16.1	1.83	18.1	2.08	20.1	2.33
	18	10.2	1.19	12.2	1.40	14.1	1.63	15.1	1.75	16.1	1.87	18.1	2.12	20.1	2.38
	20	10.2	1.21	12.2	1.43	14.1	1.66	15.1	1.78	16.1	1.91	18.1	2.16	20.1	2.43
	21	10.2	1.22	12.2	1.44	14.1	1.68	15.1	1.80	16.1	1.92	18.1	2.18	20.1	2.45
	23	10.2	1.24	12.2	1.47	14.1	1.70	15.1	1.83	16.1	1.96	18.1	2.27	20.1	2.61
	25	10.2	1.26	12.2	1.49	14.1	1.77	15.1	1.92	16.1	2.08	18.1	2.42	20.1	2.78
	27	10.2	1.31	12.2	1.58	14.1	1.89	15.1	2.05	16.1	2.22	18.1	2.58	20.1	2.97
	29	10.2	1.38	12.2	1.68	14.1	2.01	15.1	2.18	16.1	2.36	18.1	2.75	20.1	3.17
	31	10.2	1.47	12.2	1.78	14.1	2.13	15.1	2.32	16.1	2.51	18.1	2.93	20.1	3.37
	33	10.2	1.55	12.2	1.89	14.1	2.26	15.1	2.46	16.1	2.67	18.1	3.11	20.1	3.60
35	10.2	1.64	12.2	2.00	14.1	2.40	15.1	2.61	16.1	2.84	18.1	3.32	20.1	3.83	
37	10.2	1.73	12.2	2.12	14.1	2.54	15.1	2.77	16.1	3.01	18.1	3.52	20.1	4.07	
39	10.2	1.83	12.2	2.24	14.1	2.69	15.1	2.94	16.1	3.20	18.1	3.74	20.1	4.33	
41	10.2	1.89	12.2	2.34	14.1	2.79	15.1	3.06	16.1	3.32	18.1	3.92	20.1	4.53	
43	10.2	1.95	12.2	2.43	14.1	2.89	15.1	3.15	16.1	3.43	18.1	4.08	20.1	4.73	
45	10.2	2.04	12.2	2.56	14.1	3.01	15.1	3.27	16.1	3.60	18.1	4.27	20.1	4.99	
48	10.2	2.11	12.2	2.67	14.1	3.11	15.1	3.35	16.1	3.74	18.1	4.42	20.1	5.22	

Abbreviations:

CR: Combination ratio

TC: Total capacity (kW)

PI: Power input (compressor + outdoor fan motor) (kW)

Notes:

1. Shaded cells indicate rating condition.

Table continued on next page ...

# VMEX 460V 60Hz

Table 2-8.1: VMEX008Q8A-D13V224 cooling capacity (continued)

CR	Outdoor air temp. (°C DB)	Indoor air temp. (°C DB / °C WB)													
		20.8 / 14.0		23.3 / 16.0		25.8 / 18.0		27.0 / 19.0		28.2 / 20.0		30.7 / 22.0		32.0 / 24.0	
		TC	PI	TC	PI	TC	PI	TC	PI	TC	PI	TC	PI	TC	PI
		kW	kW	kW	kW	kW	kW	kW	kW	kW	kW	kW	kW	kW	kW
50%	-5	8.5	0.87	10.2	1.00	11.8	1.15	12.6	1.21	13.4	1.27	15.0	1.45	16.7	1.56
	-2	8.5	0.87	10.2	1.02	11.8	1.16	12.6	1.22	13.4	1.30	15.0	1.47	16.7	1.58
	0	8.5	0.89	10.2	1.04	11.8	1.19	12.6	1.24	13.4	1.31	15.0	1.49	16.7	1.61
	2	8.5	0.90	10.2	1.05	11.8	1.21	12.6	1.26	13.4	1.33	15.0	1.50	16.7	1.64
	4	8.5	0.91	10.2	1.07	11.8	1.22	12.6	1.27	13.4	1.36	15.0	1.54	16.7	1.68
	6	8.5	0.93	10.2	1.09	11.8	1.24	12.6	1.30	13.4	1.39	15.0	1.56	16.7	1.73
	8	8.5	0.95	10.2	1.11	11.8	1.26	12.6	1.33	13.4	1.40	15.0	1.58	16.7	1.79
	10	8.5	0.97	10.2	1.12	11.8	1.28	12.6	1.35	13.4	1.44	15.0	1.63	16.7	1.81
	12	8.5	0.98	10.2	1.13	11.8	1.30	12.6	1.38	13.4	1.47	15.0	1.65	16.7	1.84
	14	8.5	0.99	10.2	1.15	11.8	1.31	12.6	1.41	13.4	1.50	15.0	1.68	16.7	1.88
	16	8.5	1.00	10.2	1.16	11.8	1.34	12.6	1.43	13.4	1.52	15.0	1.71	16.7	1.91
	18	8.5	1.02	10.2	1.18	11.8	1.36	12.6	1.45	13.4	1.55	15.0	1.74	16.7	1.94
	20	8.5	1.03	10.2	1.20	11.8	1.38	12.6	1.47	13.4	1.57	15.0	1.77	16.7	1.98
	21	8.5	1.04	10.2	1.21	11.8	1.39	12.6	1.49	13.4	1.59	15.0	1.79	16.7	2.00
	23	8.5	1.05	10.2	1.23	11.8	1.42	12.6	1.52	13.4	1.62	15.0	1.82	16.7	2.04
	25	8.5	1.07	10.2	1.25	11.8	1.44	12.6	1.55	13.4	1.67	15.0	1.91	16.7	2.18
	27	8.5	1.09	10.2	1.30	11.8	1.52	12.6	1.65	13.4	1.77	15.0	2.04	16.7	2.33
	29	8.5	1.15	10.2	1.37	11.8	1.62	12.6	1.75	13.4	1.89	15.0	2.17	16.7	2.48
	31	8.5	1.21	10.2	1.45	11.8	1.71	12.6	1.86	13.4	2.00	15.0	2.30	16.7	2.64
	33	8.5	1.29	10.2	1.54	11.8	1.82	12.6	1.96	13.4	2.12	15.0	2.45	16.7	2.80
35	8.5	1.36	10.2	1.63	11.8	1.92	12.6	2.08	13.4	2.25	15.0	2.60	16.7	2.98	
37	8.5	1.43	10.2	1.72	11.8	2.04	12.6	2.20	13.4	2.38	15.0	2.76	16.7	3.16	
39	8.5	1.51	10.2	1.81	11.8	2.15	12.6	2.33	13.4	2.53	15.0	2.93	16.7	3.36	
41	8.5	1.57	10.2	1.89	11.8	2.23	12.6	2.44	13.4	2.64	15.0	3.08	16.7	3.51	
43	8.5	1.68	10.2	2.02	11.8	2.31	12.6	2.55	13.4	2.70	15.0	3.24	16.7	3.67	
45	8.5	1.71	10.2	2.07	11.8	2.46	12.6	2.75	13.4	2.82	15.0	3.55	16.7	3.98	
48	8.5	1.75	10.2	2.13	11.8	2.61	12.6	2.92	13.4	2.94	15.0	3.83	16.7	4.29	

Abbreviations:

CR: Combination ratio

TC: Total capacity (kW)

PI: Power input (compressor + outdoor fan motor) (kW)

Notes:

1. Shaded cells indicate rating condition.



Table 2-8.2: VMEX009Q8A-D16V280 cooling capacity

CR	Outdoor air temp. (°C DB)	Indoor air temp. (°C DB / °C WB)													
		20.8 / 14.0		23.3 / 16.0		25.8 / 18.0		27.0 / 19.0		28.2 / 20.0		30.7 / 22.0		32.0 / 24.0	
		TC	PI	TC	PI	TC	PI	TC	PI	TC	PI	TC	PI	TC	PI
		kW	kW	kW	kW	kW	kW	kW	kW	kW	kW	kW	kW	kW	kW
130%	-5	24.6	2.54	29.3	3.10	34.0	3.33	35.3	3.46	37.0	3.56	37.9	3.87	38.9	3.90
	-2	24.6	2.54	29.3	3.16	34.0	3.33	35.3	3.48	37.0	3.56	37.9	3.92	38.9	3.93
	0	24.6	2.59	29.3	3.22	34.0	3.45	35.3	3.67	37.0	3.77	37.9	3.97	38.9	3.99
	2	24.6	2.63	29.3	3.23	34.0	3.57	35.3	3.88	37.0	3.81	37.9	4.00	38.9	4.05
	4	24.6	2.69	29.3	3.29	34.0	3.69	35.3	3.90	37.0	3.86	37.9	4.06	38.9	4.12
	6	24.6	2.74	29.3	3.35	34.0	3.83	35.3	3.93	36.6	3.98	37.4	4.12	38.4	4.15
	8	24.6	2.81	29.3	3.43	34.0	4.02	35.3	4.12	36.1	4.11	37.0	4.13	37.9	4.19
	10	24.6	2.87	29.3	3.50	34.0	4.17	35.3	4.26	35.7	4.19	36.6	4.20	37.5	4.32
	12	24.6	2.92	29.3	3.57	34.0	4.25	34.8	4.32	35.3	4.25	36.1	4.26	37.0	4.34
	14	24.6	2.98	29.3	3.64	33.9	4.31	34.4	4.39	34.8	4.31	35.7	4.32	36.6	4.44
	16	24.6	3.03	29.3	3.71	33.5	4.38	33.9	4.44	34.3	4.44	35.2	4.39	36.1	4.51
	18	24.6	3.08	29.3	3.79	33.0	4.44	33.4	4.47	33.9	4.49	34.8	4.54	35.7	4.58
	20	24.6	3.15	29.3	4.03	32.5	4.66	33.0	4.69	33.4	4.71	34.3	4.75	35.2	4.80
	21	24.6	3.24	29.3	4.18	32.3	4.77	32.8	4.80	33.2	4.82	34.1	4.87	35.0	4.91
	23	24.6	3.47	29.3	4.48	31.9	4.99	32.3	5.01	32.7	5.04	33.6	5.09	34.5	5.14
	25	24.6	3.71	29.3	4.80	31.4	5.21	31.8	5.23	32.3	5.26	33.2	5.31	34.1	5.37
	27	24.6	3.96	29.3	5.13	31.0	5.42	31.4	5.46	31.8	5.48	32.7	5.54	33.6	5.60
	29	24.6	4.23	29.3	5.48	30.5	5.64	30.9	5.68	31.4	5.71	32.3	5.77	33.2	5.83
	31	24.6	4.51	29.2	5.80	30.0	5.87	30.5	5.90	30.9	5.93	31.8	5.99	32.7	6.06
	33	24.6	4.80	28.7	6.02	29.6	6.09	30.0	6.12	30.5	6.15	31.4	6.22	32.2	6.29
35	24.6	5.12	28.2	6.24	29.1	6.31	29.6	6.35	30.0	6.38	30.9	6.46	31.8	6.52	
37	24.6	5.45	27.8	6.46	28.7	6.54	29.1	6.57	29.6	6.61	30.4	6.69	31.3	6.77	
39	24.6	5.80	27.3	6.53	28.2	6.76	28.7	6.80	29.1	6.84	30.0	6.92	30.9	7.00	
41	24.6	6.11	27.0	6.59	27.9	6.82	28.4	6.86	28.8	6.90	29.7	6.93	29.7	7.06	
43	24.6	6.26	26.8	6.63	27.8	6.84	28.3	6.89	28.5	6.91	29.2	6.94	29.4	7.08	
45	24.6	6.57	26.7	6.69	27.5	6.90	28.0	6.94	28.1	6.95	28.4	6.97	28.8	7.21	
48	24.6	6.81	26.6	6.91	27.0	6.97	27.5	7.00	27.7	7.02	27.6	7.09	28.1	7.24	
120%	-5	22.7	2.46	27.0	2.97	31.4	3.52	33.6	3.84	35.2	4.00	36.0	4.13	36.8	4.24
	-2	22.7	2.48	27.0	3.01	31.4	3.55	33.6	3.86	35.2	4.05	36.0	4.16	36.8	4.25
	0	22.7	2.50	27.0	3.03	31.4	3.59	33.6	3.87	35.2	4.08	36.0	4.19	36.8	4.26
	2	22.7	2.51	27.0	3.06	31.4	3.62	33.6	3.90	35.2	4.10	36.0	4.22	36.8	4.27
	4	22.7	2.53	27.0	3.10	31.4	3.67	33.6	3.94	35.2	4.15	36.0	4.23	36.8	4.28
	6	22.7	2.56	27.0	3.12	31.4	3.71	33.6	3.98	35.2	4.20	36.0	4.26	36.8	4.29
	8	22.7	2.58	27.0	3.15	31.4	3.76	33.6	4.03	35.2	4.24	36.0	4.27	36.8	4.31
	10	22.7	2.62	27.0	3.19	31.4	3.80	33.6	4.11	35.2	4.24	36.0	4.29	36.8	4.33
	12	22.7	2.67	27.0	3.25	31.4	3.87	33.6	4.18	34.7	4.26	35.5	4.26	36.3	4.36
	14	22.7	2.72	27.0	3.32	31.4	3.95	33.6	4.27	34.2	4.29	35.1	4.33	35.9	4.41
	16	22.7	2.77	27.0	3.39	31.4	4.02	33.4	4.34	33.8	4.35	34.6	4.40	35.4	4.48
	18	22.7	2.82	27.0	3.45	31.4	4.16	32.9	4.44	33.3	4.46	34.1	4.50	35.0	4.54
	20	22.7	2.88	27.0	3.59	31.4	4.48	32.5	4.66	32.9	4.68	33.7	4.72	34.5	4.76
	21	22.7	2.90	27.0	3.71	31.4	4.64	32.2	4.77	32.6	4.79	33.5	4.83	34.3	4.88
	23	22.7	3.10	27.0	3.98	31.4	4.96	31.8	4.98	32.2	5.00	33.0	5.06	33.8	5.10
	25	22.7	3.31	27.0	4.26	30.9	5.18	31.3	5.20	31.7	5.22	32.6	5.27	33.4	5.32
	27	22.7	3.54	27.0	4.55	30.5	5.39	30.9	5.42	31.3	5.45	32.1	5.50	32.9	5.55
	29	22.7	3.77	27.0	4.86	30.0	5.61	30.4	5.64	30.8	5.67	31.6	5.73	32.5	5.78
	31	22.7	4.02	27.0	5.19	29.5	5.83	30.0	5.86	30.4	5.89	31.2	5.95	32.0	6.01
	33	22.7	4.28	27.0	5.53	29.1	6.05	29.5	6.09	29.9	6.11	30.7	6.18	31.5	6.24
35	22.7	4.56	27.0	5.90	28.6	6.27	29.0	6.30	29.5	6.34	30.3	6.40	31.1	6.47	
37	22.7	4.85	27.0	6.29	28.2	6.50	28.6	6.53	29.0	6.56	29.8	6.63	30.6	6.71	
39	22.7	5.16	26.9	6.64	27.7	6.71	28.1	6.76	28.5	6.79	29.4	6.87	30.2	6.93	
41	22.7	5.31	26.7	6.69	27.5	6.76	27.9	6.80	28.3	6.84	29.2	6.88	29.3	6.98	
43	22.7	5.38	26.5	6.73	27.3	6.80	27.7	6.83	28.1	6.86	28.7	6.90	28.9	7.12	
45	22.7	5.45	26.4	6.80	27.0	6.87	27.4	6.89	27.8	6.92	28.1	6.92	28.6	7.28	
48	22.7	5.49	26.2	6.87	26.7	6.93	26.9	6.95	27.5	6.97	27.7	6.95	28.2	7.37	

Abbreviations:

CR: Combination ratio

TC: Total capacity (kW)

PI: Power input (compressor + outdoor fan motor) (kW)

Notes:

1. Shaded cells indicate rating condition.

Table continued on next page ...

# VMEX 460V 60Hz

Table 2-8.2: VMEX009Q8A-D16V280 cooling capacity (continued)

CR	Outdoor air temp. (°C DB)	Indoor air temp. (°C DB / °C WB)													
		20.8 / 14.0		23.3 / 16.0		25.8 / 18.0		27.0 / 19.0		28.2 / 20.0		30.7 / 22.0		32.0 / 24.0	
		TC	PI	TC	PI	TC	PI	TC	PI	TC	PI	TC	PI	TC	PI
		kW	kW	kW	kW	kW	kW	kW	kW	kW	kW	kW	kW	kW	kW
110%	-5	20.8	2.14	24.8	2.67	28.8	3.19	30.8	3.42	32.8	3.68	35.3	3.82	36.1	3.94
	-2	20.8	2.19	24.8	2.70	28.8	3.21	30.8	3.45	32.8	3.71	35.3	3.86	36.1	3.96
	0	20.8	2.21	24.8	2.72	28.8	3.24	30.8	3.48	32.8	3.75	35.3	3.90	36.1	4.01
	2	20.8	2.26	24.8	2.75	28.8	3.29	30.8	3.51	32.8	3.79	35.3	3.95	36.1	4.06
	4	20.8	2.30	24.8	2.78	28.8	3.32	30.8	3.56	32.8	3.85	35.3	4.01	36.1	4.10
	6	20.8	2.32	24.8	2.81	28.8	3.35	30.8	3.61	32.8	3.89	35.3	4.05	36.1	4.16
	8	20.8	2.34	24.8	2.85	28.8	3.39	30.8	3.65	32.8	3.93	35.3	4.08	36.1	4.20
	10	20.8	2.37	24.8	2.89	28.8	3.44	30.8	3.71	32.8	4.00	35.3	4.11	36.1	4.24
	12	20.8	2.42	24.8	2.95	28.8	3.50	30.8	3.79	32.8	4.07	34.9	4.17	35.6	4.29
	14	20.8	2.46	24.8	3.00	28.8	3.57	30.8	3.86	32.8	4.15	34.4	4.20	35.2	4.32
	16	20.8	2.51	24.8	3.06	28.8	3.64	30.8	3.93	32.8	4.23	34.0	4.25	34.7	4.37
	18	20.8	2.56	24.8	3.12	28.8	3.71	30.8	4.04	32.8	4.43	33.5	4.47	34.3	4.51
	20	20.8	2.61	24.8	3.19	28.8	3.93	30.8	4.34	32.3	4.65	33.1	4.69	33.8	4.73
	21	20.8	2.63	24.8	3.28	28.8	4.07	30.8	4.50	32.1	4.76	32.8	4.80	33.6	4.84
	23	20.8	2.76	24.8	3.51	28.8	4.37	30.8	4.83	31.6	4.97	32.4	5.02	33.1	5.06
	25	20.8	2.94	24.8	3.76	28.8	4.67	30.8	5.17	31.2	5.19	31.9	5.24	32.7	5.28
	27	20.8	3.14	24.8	4.02	28.8	5.00	30.3	5.39	30.7	5.41	31.5	5.46	32.2	5.51
	29	20.8	3.34	24.8	4.28	28.8	5.34	29.9	5.61	30.3	5.63	31.0	5.68	31.8	5.73
	31	20.8	3.56	24.8	4.57	28.8	5.70	29.4	5.83	29.8	5.85	30.6	5.90	31.3	5.96
	33	20.8	3.79	24.8	4.87	28.6	6.01	29.0	6.04	29.4	6.07	30.1	6.13	30.9	6.19
35	20.8	4.03	24.8	5.19	28.1	6.23	28.5	6.26	28.9	6.30	29.6	6.35	30.4	6.41	
37	20.8	4.29	24.8	5.52	27.7	6.46	28.1	6.48	28.4	6.51	29.2	6.58	29.9	6.64	
39	20.8	4.56	24.8	5.89	27.2	6.67	27.6	6.71	28.0	6.74	28.7	6.81	29.5	6.87	
41	20.8	4.61	24.8	5.93	27.0	6.72	27.4	6.75	27.8	6.79	28.3	6.85	28.6	6.92	
43	20.8	4.65	24.8	6.01	26.8	6.77	27.2	6.80	27.6	6.83	28.1	6.88	28.2	7.06	
45	20.8	4.80	24.8	6.04	26.5	6.83	26.9	6.88	27.3	6.90	27.8	7.07	27.9	7.23	
48	20.8	4.97	24.8	6.55	26.1	6.88	26.5	6.93	27.0	6.97	27.3	7.09	27.6	7.30	
100%	-5	18.9	1.95	22.5	2.35	26.2	2.80	28.0	3.00	29.8	3.25	33.5	3.71	35.4	3.87
	-2	18.9	1.98	22.5	2.38	26.2	2.83	28.0	3.05	29.8	3.30	33.5	3.75	35.4	3.89
	0	18.9	2.00	22.5	2.41	26.2	2.86	28.0	3.09	29.8	3.33	33.5	3.81	35.4	3.94
	2	18.9	2.04	22.5	2.44	26.2	2.89	28.0	3.13	29.8	3.37	33.5	3.87	35.4	4.00
	4	18.9	2.05	22.5	2.46	26.2	2.94	28.0	3.18	29.8	3.41	33.5	3.91	35.4	4.04
	6	18.9	2.08	22.5	2.51	26.2	2.97	28.0	3.23	29.8	3.46	33.5	3.96	35.4	4.11
	8	18.9	2.12	22.5	2.55	26.2	3.03	28.0	3.27	29.8	3.51	33.5	4.02	35.4	4.17
	10	18.9	2.15	22.5	2.60	26.2	3.08	28.0	3.33	29.8	3.58	33.5	4.09	35.4	4.23
	12	18.9	2.18	22.5	2.65	26.2	3.13	28.0	3.39	29.8	3.65	33.5	4.17	34.9	4.27
	14	18.9	2.22	22.5	2.70	26.2	3.19	28.0	3.45	29.8	3.71	33.5	4.25	34.5	4.32
	16	18.9	2.26	22.5	2.75	26.2	3.26	28.0	3.52	29.8	3.79	33.3	4.30	34.0	4.37
	18	18.9	2.31	22.5	2.80	26.2	3.32	28.0	3.59	29.8	3.86	32.9	4.44	33.6	4.48
	20	18.9	2.35	22.5	2.86	26.2	3.42	28.0	3.77	29.8	4.14	32.4	4.65	33.1	4.69
	21	18.9	2.37	22.5	2.88	26.2	3.55	28.0	3.91	29.8	4.28	32.2	4.76	32.9	4.80
	23	18.9	2.43	22.5	3.08	26.2	3.80	28.0	4.18	29.8	4.59	31.8	4.98	32.4	5.02
	25	18.9	2.59	22.5	3.29	26.2	4.07	28.0	4.48	29.8	4.92	31.3	5.20	32.0	5.24
	27	18.9	2.77	22.5	3.50	26.2	4.34	28.0	4.79	29.8	5.26	30.8	5.42	31.5	5.47
	29	18.9	2.94	22.5	3.74	26.2	4.64	28.0	5.12	29.7	5.59	30.4	5.64	31.1	5.68
	31	18.9	3.13	22.5	3.99	26.2	4.95	28.0	5.47	29.3	5.81	29.9	5.86	30.6	5.91
	33	18.9	3.33	22.5	4.25	26.2	5.27	28.0	5.83	28.8	6.03	29.5	6.08	30.2	6.14
35	18.9	3.54	22.5	4.52	26.2	5.62	<b>28.0</b>	<b>6.22</b>	28.3	6.24	29.0	6.30	29.7	6.35	
37	18.9	3.76	22.5	4.81	26.2	5.99	27.5	6.44	27.9	6.47	28.6	6.53	29.2	6.58	
39	18.9	4.00	22.5	5.11	26.2	6.38	27.1	6.66	27.4	6.69	28.1	6.75	28.8	6.82	
41	18.9	4.18	22.5	5.30	26.2	6.61	26.7	6.70	27.2	6.79	27.6	6.91	28.4	6.96	
43	18.9	4.37	22.5	5.49	26.2	6.74	26.3	6.78	27.0	6.86	27.8	6.95	27.9	7.03	
45	18.9	4.62	22.5	5.74	26.2	6.85	25.7	6.87	26.9	6.98	27.5	7.06	27.3	7.13	
48	18.9	4.82	22.5	5.94	26.2	6.86	24.6	6.95	26.8	7.11	25.9	7.13	26.7	7.19	

Abbreviations:

CR: Combination ratio

TC: Total capacity (kW)

PI: Power input (compressor + outdoor fan motor) (kW)

Notes:

1. Shaded cells indicate rating condition.

Table continued on next page ...

Table 2-8.2: VMEX009Q8A-D16V280 cooling capacity (continued)

CR	Outdoor air temp. (°C DB)	Indoor air temp. (°C DB / °C WB)													
		20.8 / 14.0		23.3 / 16.0		25.8 / 18.0		27.0 / 19.0		28.2 / 20.0		30.7 / 22.0		32.0 / 24.0	
		TC kW	PI kW	TC kW	PI kW	TC kW	PI kW	TC kW	PI kW	TC kW	PI kW	TC kW	PI kW	TC kW	PI kW
90%	-5	17.0	1.73	20.3	2.07	23.6	2.44	25.2	2.67	26.8	2.84	30.1	3.26	33.4	3.74
	-2	17.0	1.74	20.3	2.09	23.6	2.48	25.2	2.71	26.8	2.87	30.1	3.29	33.4	3.77
	0	17.0	1.77	20.3	2.12	23.6	2.51	25.2	2.74	26.8	2.91	30.1	3.33	33.4	3.80
	2	17.0	1.80	20.3	2.15	23.6	2.54	25.2	2.78	26.8	2.95	30.1	3.40	33.4	3.86
	4	17.0	1.82	20.3	2.18	23.6	2.58	25.2	2.82	26.8	2.99	30.1	3.45	33.4	3.91
	6	17.0	1.85	20.3	2.22	23.6	2.63	25.2	2.87	26.8	3.04	30.1	3.51	33.4	3.98
	8	17.0	1.88	20.3	2.26	23.6	2.68	25.2	2.91	26.8	3.10	30.1	3.57	33.4	4.02
	10	17.0	1.92	20.3	2.31	23.6	2.73	25.2	2.95	26.8	3.17	30.1	3.62	33.4	4.08
	12	17.0	1.95	20.3	2.36	23.6	2.78	25.2	3.00	26.8	3.23	30.1	3.69	33.4	4.16
	14	17.0	1.99	20.3	2.40	23.6	2.83	25.2	3.06	26.8	3.29	30.1	3.76	33.4	4.23
	16	17.0	2.02	20.3	2.44	23.6	2.89	25.2	3.12	26.8	3.35	30.1	3.83	33.3	4.31
	18	17.0	2.05	20.3	2.49	23.6	2.94	25.2	3.18	26.8	3.42	30.1	3.91	32.9	4.44
	20	17.0	2.10	20.3	2.55	23.6	3.00	25.2	3.24	26.8	3.55	30.1	4.20	32.4	4.65
	21	17.0	2.11	20.3	2.56	23.6	3.05	25.2	3.35	26.8	3.67	30.1	4.35	32.2	4.76
	23	17.0	2.15	20.3	2.67	23.6	3.27	25.2	3.60	26.8	3.94	30.1	4.67	31.7	4.98
	25	17.0	2.27	20.3	2.85	23.6	3.50	25.2	3.85	26.8	4.21	30.1	5.00	31.3	5.20
	27	17.0	2.41	20.3	3.03	23.6	3.73	25.2	4.11	26.8	4.50	30.1	5.35	30.8	5.41
	29	17.0	2.57	20.3	3.24	23.6	3.98	25.2	4.38	26.8	4.81	29.8	5.59	30.4	5.63
	31	17.0	2.73	20.3	3.45	23.6	4.24	25.2	4.68	26.8	5.13	29.3	5.81	29.9	5.86
	33	17.0	2.90	20.3	3.66	23.6	4.53	25.2	4.99	26.8	5.47	28.9	6.03	29.5	6.08
35	17.0	3.08	20.3	3.90	23.6	4.82	25.2	5.31	26.8	5.83	28.4	6.25	29.0	6.30	
37	17.0	3.27	20.3	4.14	23.6	5.13	25.2	5.66	26.8	6.22	27.9	6.47	28.6	6.52	
39	17.0	3.47	20.3	4.41	23.6	5.46	25.2	6.03	26.8	6.62	27.5	6.70	28.1	6.75	
41	17.0	3.59	20.3	4.61	23.6	5.66	25.2	6.19	26.8	6.66	27.3	6.87	27.9	6.91	
43	17.0	3.76	20.3	4.81	23.6	5.86	25.2	6.35	26.8	6.80	27.2	6.96	27.7	7.01	
45	17.0	4.00	20.3	5.05	23.6	6.09	25.2	6.56	26.8	6.99	27.0	7.03	27.2	7.11	
48	17.0	4.22	20.3	5.28	23.6	6.32	25.2	6.64	26.8	7.05	26.8	7.13	26.5	7.20	
80%	-5	15.1	1.52	18.0	1.80	20.9	2.13	22.4	2.27	23.9	2.44	26.8	2.82	29.7	3.22
	-2	15.1	1.54	18.0	1.82	20.9	2.15	22.4	2.30	23.9	2.46	26.8	2.85	29.7	3.25
	0	15.1	1.57	18.0	1.84	20.9	2.18	22.4	2.33	23.9	2.51	26.8	2.89	29.7	3.29
	2	15.1	1.60	18.0	1.87	20.9	2.21	22.4	2.37	23.9	2.55	26.8	2.95	29.7	3.36
	4	15.1	1.63	18.0	1.90	20.9	2.25	22.4	2.43	23.9	2.60	26.8	3.00	29.7	3.40
	6	15.1	1.66	18.0	1.95	20.9	2.28	22.4	2.48	23.9	2.65	26.8	3.04	29.7	3.46
	8	15.1	1.69	18.0	1.99	20.9	2.34	22.4	2.52	23.9	2.70	26.8	3.09	29.7	3.53
	10	15.1	1.70	18.0	2.04	20.9	2.40	22.4	2.58	23.9	2.77	26.8	3.16	29.7	3.56
	12	15.1	1.73	18.0	2.07	20.9	2.44	22.4	2.63	23.9	2.83	26.8	3.22	29.7	3.63
	14	15.1	1.76	18.0	2.11	20.9	2.48	22.4	2.67	23.9	2.88	26.8	3.28	29.7	3.70
	16	15.1	1.79	18.0	2.15	20.9	2.53	22.4	2.72	23.9	2.93	26.8	3.34	29.7	3.76
	18	15.1	1.82	18.0	2.19	20.9	2.58	22.4	2.78	23.9	2.98	26.8	3.41	29.7	3.84
	20	15.1	1.85	18.0	2.23	20.9	2.63	22.4	2.83	23.9	3.04	26.8	3.54	29.7	4.11
	21	15.1	1.87	18.0	2.25	20.9	2.66	22.4	2.87	23.9	3.11	26.8	3.66	29.7	4.26
	23	15.1	1.90	18.0	2.30	20.9	2.78	22.4	3.05	23.9	3.33	26.8	3.92	29.7	4.57
	25	15.1	1.96	18.0	2.44	20.9	2.98	22.4	3.26	23.9	3.55	26.8	4.20	29.7	4.89
	27	15.1	2.09	18.0	2.60	20.9	3.17	22.4	3.48	23.9	3.80	26.8	4.49	29.7	5.23
	29	15.1	2.22	18.0	2.77	20.9	3.38	22.4	3.71	23.9	4.06	26.8	4.79	29.7	5.59
	31	15.1	2.36	18.0	2.94	20.9	3.60	22.4	3.95	23.9	4.33	26.8	5.11	29.2	5.81
	33	15.1	2.51	18.0	3.13	20.9	3.83	22.4	4.21	23.9	4.60	26.8	5.45	28.8	6.03
35	15.1	2.66	18.0	3.33	20.9	4.07	22.4	4.48	23.9	4.90	26.8	5.81	28.3	6.25	
37	15.1	2.82	18.0	3.53	20.9	4.33	22.4	4.77	23.9	5.22	26.8	6.20	27.9	6.46	
39	15.1	2.98	18.0	3.76	20.9	4.61	22.4	5.07	23.9	5.56	26.8	6.60	27.4	6.69	
41	15.1	3.05	18.0	3.80	20.9	4.68	22.4	5.21	23.9	5.66	26.8	6.77	27.2	6.81	
43	15.1	3.14	18.0	3.83	20.9	4.75	22.4	5.30	23.9	5.74	26.8	6.84	27.1	6.88	
45	15.1	3.23	18.0	3.88	20.9	4.84	22.4	5.41	23.9	5.84	26.8	6.92	26.7	6.99	
48	15.1	3.34	18.0	3.90	20.9	4.91	22.4	5.48	23.9	5.89	26.8	6.99	26.5	7.09	

Abbreviations:

CR: Combination ratio

TC: Total capacity (kW)

PI: Power input (compressor + outdoor fan motor) (kW)

Notes:

1. Shaded cells indicate rating condition.

Table continued on next page ...

# VMEX 460V 60Hz

Table 2-8.2: VMEX009Q8A-D16V280 cooling capacity (continued)

CR	Outdoor air temp. (°C DB)	Indoor air temp. (°C DB / °C WB)													
		20.8 / 14.0		23.3 / 16.0		25.8 / 18.0		27.0 / 19.0		28.2 / 20.0		30.7 / 22.0		32.0 / 24.0	
		TC	PI	TC	PI	TC	PI	TC	PI	TC	PI	TC	PI	TC	PI
		kW	kW	kW	kW	kW	kW	kW	kW	kW	kW	kW	kW	kW	kW
70%	-5	13.2	1.36	15.8	1.59	18.3	1.81	19.6	1.94	20.9	2.07	23.4	2.36	26.0	2.72
	-2	13.2	1.37	15.8	1.60	18.3	1.82	19.6	1.97	20.9	2.10	23.4	2.40	26.0	2.75
	0	13.2	1.38	15.8	1.62	18.3	1.85	19.6	2.01	20.9	2.14	23.4	2.45	26.0	2.79
	2	13.2	1.38	15.8	1.63	18.3	1.88	19.6	2.05	20.9	2.18	23.4	2.50	26.0	2.84
	4	13.2	1.40	15.8	1.67	18.3	1.93	19.6	2.08	20.9	2.23	23.4	2.54	26.0	2.90
	6	13.2	1.43	15.8	1.70	18.3	1.97	19.6	2.15	20.9	2.28	23.4	2.59	26.0	2.96
	8	13.2	1.45	15.8	1.75	18.3	2.02	19.6	2.18	20.9	2.33	23.4	2.66	26.0	3.01
	10	13.2	1.48	15.8	1.78	18.3	2.07	19.6	2.23	20.9	2.39	23.4	2.72	26.0	3.05
	12	13.2	1.52	15.8	1.80	18.3	2.11	19.6	2.27	20.9	2.43	23.4	2.77	26.0	3.11
	14	13.2	1.54	15.8	1.84	18.3	2.15	19.6	2.31	20.9	2.47	23.4	2.82	26.0	3.17
	16	13.2	1.57	15.8	1.87	18.3	2.19	19.6	2.36	20.9	2.52	23.4	2.87	26.0	3.23
	18	13.2	1.59	15.8	1.90	18.3	2.23	19.6	2.40	20.9	2.57	23.4	2.93	26.0	3.29
	20	13.2	1.62	15.8	1.94	18.3	2.27	19.6	2.44	20.9	2.62	23.4	2.98	26.0	3.39
	21	13.2	1.63	15.8	1.95	18.3	2.29	19.6	2.46	20.9	2.64	23.4	3.03	26.0	3.50
	23	13.2	1.66	15.8	1.99	18.3	2.34	19.6	2.55	20.9	2.77	23.4	3.24	26.0	3.76
	25	13.2	1.69	15.8	2.07	18.3	2.49	19.6	2.72	20.9	2.96	23.4	3.47	26.0	4.02
	27	13.2	1.79	15.8	2.20	18.3	2.66	19.6	2.90	20.9	3.16	23.4	3.71	26.0	4.29
	29	13.2	1.90	15.8	2.34	18.3	2.83	19.6	3.09	20.9	3.36	23.4	3.95	26.0	4.59
	31	13.2	2.01	15.8	2.48	18.3	3.01	19.6	3.29	20.9	3.58	23.4	4.21	26.0	4.89
	33	13.2	2.14	15.8	2.64	18.3	3.20	19.6	3.50	20.9	3.81	23.4	4.49	26.0	5.21
35	13.2	2.26	15.8	2.80	18.3	3.40	19.6	3.72	20.9	4.06	23.4	4.78	26.0	5.56	
37	13.2	2.39	15.8	2.97	18.3	3.61	19.6	3.95	20.9	4.32	23.4	5.09	26.0	5.92	
39	13.2	2.53	15.8	3.14	18.3	3.83	19.6	4.20	20.9	4.59	23.4	5.41	26.0	6.30	
41	13.2	2.64	15.8	3.26	18.3	3.94	19.6	4.34	20.9	4.73	23.4	5.63	26.0	6.58	
43	13.2	2.86	15.8	3.48	18.3	4.11	19.6	4.57	20.9	4.86	23.4	5.84	26.0	6.79	
45	13.2	2.92	15.8	3.55	18.3	4.19	19.6	4.65	20.9	5.11	23.4	6.15	26.0	7.05	
48	13.2	3.00	15.8	3.59	18.3	4.23	19.6	4.72	20.9	5.25	23.4	6.43	26.0	7.21	
60%	-5	11.3	1.16	13.5	1.34	15.7	1.57	16.8	1.67	17.9	1.80	20.1	2.02	22.3	2.32
	-2	11.3	1.17	13.5	1.37	15.7	1.60	16.8	1.69	17.9	1.82	20.1	2.05	22.3	2.34
	0	11.3	1.18	13.5	1.38	15.7	1.62	16.8	1.71	17.9	1.85	20.1	2.08	22.3	2.37
	2	11.3	1.20	13.5	1.41	15.7	1.65	16.8	1.75	17.9	1.88	20.1	2.13	22.3	2.40
	4	11.3	1.24	13.5	1.44	15.7	1.68	16.8	1.77	17.9	1.90	20.1	2.16	22.3	2.43
	6	11.3	1.25	13.5	1.47	15.7	1.71	16.8	1.81	17.9	1.94	20.1	2.20	22.3	2.49
	8	11.3	1.27	13.5	1.49	15.7	1.74	16.8	1.84	17.9	1.98	20.1	2.25	22.3	2.53
	10	11.3	1.30	13.5	1.53	15.7	1.77	16.8	1.89	17.9	2.02	20.1	2.29	22.3	2.56
	12	11.3	1.32	13.5	1.55	15.7	1.80	16.8	1.93	17.9	2.05	20.1	2.33	22.3	2.61
	14	11.3	1.34	13.5	1.58	15.7	1.83	16.8	1.96	17.9	2.10	20.1	2.37	22.3	2.66
	16	11.3	1.36	13.5	1.60	15.7	1.86	16.8	1.99	17.9	2.13	20.1	2.41	22.3	2.71
	18	11.3	1.38	13.5	1.63	15.7	1.89	16.8	2.03	17.9	2.17	20.1	2.46	22.3	2.76
	20	11.3	1.40	13.5	1.66	15.7	1.93	16.8	2.07	17.9	2.21	20.1	2.51	22.3	2.82
	21	11.3	1.42	13.5	1.67	15.7	1.94	16.8	2.09	17.9	2.23	20.1	2.53	22.3	2.84
	23	11.3	1.43	13.5	1.70	15.7	1.98	16.8	2.13	17.9	2.27	20.1	2.63	22.3	3.03
	25	11.3	1.46	13.5	1.73	15.7	2.05	16.8	2.23	17.9	2.41	20.1	2.81	22.3	3.23
	27	11.3	1.52	13.5	1.84	15.7	2.19	16.8	2.38	17.9	2.57	20.1	2.99	22.3	3.44
	29	11.3	1.60	13.5	1.94	15.7	2.33	16.8	2.53	17.9	2.74	20.1	3.19	22.3	3.68
	31	11.3	1.70	13.5	2.06	15.7	2.47	16.8	2.69	17.9	2.92	20.1	3.39	22.3	3.91
	33	11.3	1.79	13.5	2.19	15.7	2.62	16.8	2.86	17.9	3.10	20.1	3.61	22.3	4.17
35	11.3	1.90	13.5	2.32	15.7	2.78	16.8	3.03	17.9	3.29	20.1	3.85	22.3	4.44	
37	11.3	2.01	13.5	2.46	15.7	2.95	16.8	3.22	17.9	3.49	20.1	4.09	22.3	4.73	
39	11.3	2.12	13.5	2.60	15.7	3.13	16.8	3.41	17.9	3.71	20.1	4.34	22.3	5.03	
41	11.3	2.19	13.5	2.71	15.7	3.24	16.8	3.55	17.9	3.85	20.1	4.55	22.3	5.26	
43	11.3	2.26	13.5	2.82	15.7	3.35	16.8	3.65	17.9	3.98	20.1	4.74	22.3	5.48	
45	11.3	2.36	13.5	2.97	15.7	3.49	16.8	3.79	17.9	4.18	20.1	4.95	22.3	5.79	
48	11.3	2.45	13.5	3.10	15.7	3.61	16.8	3.89	17.9	4.34	20.1	5.13	22.3	6.06	

**Abbreviations:**

CR: Combination ratio

TC: Total capacity (kW)

PI: Power input (compressor + outdoor fan motor) (kW)

**Notes:**

1. Shaded cells indicate rating condition.

Table continued on next page ...

Table 2-8.2: VMEX009Q8A-D16V280 cooling capacity (continued)

CR	Outdoor air temp. (°C DB)	Indoor air temp. (°C DB / °C WB)													
		20.8 / 14.0		23.3 / 16.0		25.8 / 18.0		27.0 / 19.0		28.2 / 20.0		30.7 / 22.0		32.0 / 24.0	
		TC	PI	TC	PI	TC	PI	TC	PI	TC	PI	TC	PI	TC	PI
		kW	kW	kW	kW	kW	kW	kW	kW	kW	kW	kW	kW	kW	kW
50%	-5	9.5	1.01	11.3	1.16	13.1	1.34	14.0	1.40	14.9	1.48	16.7	1.68	18.6	1.81
	-2	9.5	1.01	11.3	1.19	13.1	1.35	14.0	1.42	14.9	1.50	16.7	1.70	18.6	1.83
	0	9.5	1.03	11.3	1.21	13.1	1.38	14.0	1.44	14.9	1.52	16.7	1.73	18.6	1.87
	2	9.5	1.05	11.3	1.22	13.1	1.40	14.0	1.46	14.9	1.55	16.7	1.74	18.6	1.90
	4	9.5	1.06	11.3	1.24	13.1	1.41	14.0	1.48	14.9	1.58	16.7	1.78	18.6	1.95
	6	9.5	1.07	11.3	1.26	13.1	1.44	14.0	1.51	14.9	1.61	16.7	1.81	18.6	2.01
	8	9.5	1.10	11.3	1.28	13.1	1.46	14.0	1.54	14.9	1.63	16.7	1.84	18.6	2.07
	10	9.5	1.12	11.3	1.30	13.1	1.48	14.0	1.57	14.9	1.68	16.7	1.89	18.6	2.10
	12	9.5	1.13	11.3	1.32	13.1	1.51	14.0	1.60	14.9	1.71	16.7	1.92	18.6	2.14
	14	9.5	1.15	11.3	1.33	13.1	1.53	14.0	1.63	14.9	1.74	16.7	1.95	18.6	2.18
	16	9.5	1.16	11.3	1.35	13.1	1.55	14.0	1.66	14.9	1.76	16.7	1.99	18.6	2.21
	18	9.5	1.18	11.3	1.37	13.1	1.58	14.0	1.68	14.9	1.79	16.7	2.02	18.6	2.25
	20	9.5	1.20	11.3	1.39	13.1	1.60	14.0	1.71	14.9	1.83	16.7	2.05	18.6	2.30
	21	9.5	1.21	11.3	1.41	13.1	1.62	14.0	1.73	14.9	1.84	16.7	2.08	18.6	2.32
	23	9.5	1.22	11.3	1.42	13.1	1.64	14.0	1.76	14.9	1.88	16.7	2.11	18.6	2.37
	25	9.5	1.24	11.3	1.45	13.1	1.68	14.0	1.79	14.9	1.94	16.7	2.22	18.6	2.53
	27	9.5	1.27	11.3	1.51	13.1	1.77	14.0	1.91	14.9	2.05	16.7	2.36	18.6	2.70
	29	9.5	1.33	11.3	1.59	13.1	1.88	14.0	2.03	14.9	2.19	16.7	2.51	18.6	2.88
	31	9.5	1.41	11.3	1.68	13.1	1.99	14.0	2.15	14.9	2.32	16.7	2.67	18.6	3.06
	33	9.5	1.49	11.3	1.79	13.1	2.11	14.0	2.28	14.9	2.46	16.7	2.84	18.6	3.25
35	9.5	1.58	11.3	1.89	13.1	2.23	14.0	2.41	14.9	2.61	16.7	3.02	18.6	3.45	
37	9.5	1.66	11.3	1.99	13.1	2.36	14.0	2.56	14.9	2.77	16.7	3.20	18.6	3.67	
39	9.5	1.75	11.3	2.10	13.1	2.50	14.0	2.71	14.9	2.93	16.7	3.39	18.6	3.90	
41	9.5	1.82	11.3	2.19	13.1	2.59	14.0	2.83	14.9	3.06	16.7	3.58	18.6	4.08	
43	9.5	1.94	11.3	2.35	13.1	2.68	14.0	2.96	14.9	3.14	16.7	3.76	18.6	4.26	
45	9.5	1.99	11.3	2.41	13.1	2.86	14.0	3.19	14.9	3.27	16.7	4.12	18.6	4.62	
48	9.5	2.04	11.3	2.47	13.1	3.03	14.0	3.39	14.9	3.42	16.7	4.45	18.6	4.97	

Abbreviations:

CR: Combination ratio

TC: Total capacity (kW)

PI: Power input (compressor + outdoor fan motor) (kW)

Notes:

1. Shaded cells indicate rating condition.

# VMEX 460V 60Hz

Table 2-8.3: VMEX010Q8A-D20V335 cooling capacity

CR	Outdoor air temp. (°C DB)	Indoor air temp. (°C DB / °C WB)													
		20.8 / 14.0		23.3 / 16.0		25.8 / 18.0		27.0 / 19.0		28.2 / 20.0		30.7 / 22.0		32.0 / 24.0	
		TC	PI	TC	PI	TC	PI	TC	PI	TC	PI	TC	PI	TC	PI
		kW	kW	kW	kW	kW	kW	kW	kW	kW	kW	kW	kW	kW	kW
130%	-5	29.4	3.18	35.1	3.89	40.7	4.17	42.2	4.34	44.3	4.46	45.3	4.85	46.5	4.88
	-2	29.4	3.18	35.1	3.96	40.7	4.17	42.2	4.36	44.3	4.46	45.3	4.91	46.5	4.93
	0	29.4	3.24	35.1	4.03	40.7	4.32	42.2	4.60	44.3	4.72	45.3	4.97	46.5	4.99
	2	29.4	3.30	35.1	4.04	40.7	4.47	42.2	4.86	44.3	4.77	45.3	5.01	46.5	5.07
	4	29.4	3.37	35.1	4.12	40.7	4.62	42.2	4.88	44.3	4.83	45.3	5.08	46.5	5.16
	6	29.4	3.44	35.1	4.20	40.7	4.79	42.2	4.92	43.8	4.98	44.8	5.16	46.0	5.20
	8	29.4	3.52	35.1	4.30	40.7	5.03	42.2	5.16	43.2	5.15	44.3	5.18	45.4	5.25
	10	29.4	3.59	35.1	4.39	40.7	5.22	42.2	5.33	42.7	5.24	43.8	5.26	44.9	5.40
	12	29.4	3.65	35.1	4.47	40.7	5.32	41.6	5.41	42.2	5.32	43.2	5.34	44.3	5.44
	14	29.4	3.73	35.1	4.56	40.6	5.40	41.2	5.49	41.6	5.40	42.7	5.42	43.8	5.56
	16	29.4	3.79	35.1	4.65	40.1	5.48	40.6	5.56	41.0	5.56	42.1	5.50	43.2	5.65
	18	29.4	3.86	35.1	4.75	39.5	5.56	40.0	5.60	40.6	5.63	41.6	5.68	42.7	5.73
	20	29.4	3.95	35.1	5.05	38.9	5.84	39.5	5.87	40.0	5.90	41.0	5.95	42.1	6.02
	21	29.4	4.05	35.1	5.23	38.6	5.97	39.2	6.01	39.7	6.04	40.8	6.10	41.9	6.15
	23	29.4	4.35	35.1	5.61	38.2	6.25	38.6	6.28	39.1	6.31	40.2	6.37	41.3	6.44
	25	29.4	4.64	35.1	6.01	37.6	6.52	38.0	6.55	38.6	6.59	39.7	6.66	40.8	6.72
	27	29.4	4.96	35.1	6.43	37.1	6.79	37.6	6.83	38.0	6.87	39.1	6.94	40.2	7.01
	29	29.4	5.29	35.1	6.87	36.5	7.07	37.0	7.11	37.6	7.15	38.6	7.22	39.7	7.30
	31	29.4	5.65	34.9	7.27	35.9	7.35	36.5	7.39	37.0	7.42	38.0	7.51	39.1	7.59
	33	29.4	6.02	34.3	7.54	35.4	7.62	35.9	7.66	36.5	7.71	37.6	7.79	38.5	7.88
	35	29.4	6.41	33.7	7.81	34.8	7.91	35.4	7.95	35.9	7.99	37.0	8.08	38.0	8.17
	37	29.4	6.83	33.3	8.10	34.3	8.19	34.8	8.23	35.4	8.28	36.4	8.38	37.4	8.47
	39	29.4	7.27	32.7	8.18	33.7	8.46	34.3	8.51	34.8	8.57	35.9	8.66	37.0	8.77
	41	29.4	7.65	32.3	8.26	33.4	8.54	34.0	8.59	34.5	8.65	35.5	8.68	35.6	8.85
43	29.4	7.84	32.1	8.30	33.2	8.57	33.8	8.63	34.1	8.66	34.9	8.70	35.1	8.87	
45	29.4	8.23	31.9	8.38	32.9	8.65	33.5	8.69	33.6	8.70	33.9	8.73	34.4	9.03	
48	29.4	8.52	31.8	8.65	32.3	8.73	32.9	8.77	33.2	8.80	33.0	8.88	33.6	9.06	
120%	-5	27.2	3.08	32.3	3.72	37.6	4.41	40.2	4.80	42.1	5.01	43.1	5.17	44.0	5.31
	-2	27.2	3.11	32.3	3.76	37.6	4.45	40.2	4.83	42.1	5.07	43.1	5.21	44.0	5.32
	0	27.2	3.13	32.3	3.79	37.6	4.50	40.2	4.84	42.1	5.11	43.1	5.24	44.0	5.33
	2	27.2	3.14	32.3	3.83	37.6	4.53	40.2	4.89	42.1	5.13	43.1	5.28	44.0	5.35
	4	27.2	3.17	32.3	3.88	37.6	4.59	40.2	4.93	42.1	5.20	43.1	5.29	44.0	5.36
	6	27.2	3.21	32.3	3.91	37.6	4.65	40.2	4.99	42.1	5.26	43.1	5.34	44.0	5.38
	8	27.2	3.24	32.3	3.95	37.6	4.71	40.2	5.05	42.1	5.31	43.1	5.35	44.0	5.40
	10	27.2	3.28	32.3	4.00	37.6	4.76	40.2	5.14	42.1	5.31	43.1	5.37	44.0	5.43
	12	27.2	3.34	32.3	4.07	37.6	4.85	40.2	5.24	41.5	5.34	42.5	5.34	43.4	5.46
	14	27.2	3.40	32.3	4.16	37.6	4.94	40.2	5.34	40.9	5.37	42.0	5.42	43.0	5.53
	16	27.2	3.46	32.3	4.24	37.6	5.04	40.0	5.44	40.4	5.45	41.4	5.51	42.4	5.61
	18	27.2	3.53	32.3	4.33	37.6	5.21	39.4	5.56	39.8	5.59	40.8	5.64	41.9	5.69
	20	27.2	3.60	32.3	4.49	37.6	5.61	38.9	5.84	39.4	5.86	40.3	5.91	41.3	5.96
	21	27.2	3.63	32.3	4.65	37.6	5.81	38.5	5.97	39.0	5.99	40.1	6.05	41.0	6.11
	23	27.2	3.88	32.3	4.99	37.6	6.22	38.0	6.24	38.5	6.27	39.5	6.33	40.4	6.38
	25	27.2	4.15	32.3	5.33	37.0	6.49	37.4	6.51	37.9	6.54	39.0	6.60	40.0	6.67
	27	27.2	4.43	32.3	5.70	36.5	6.75	37.0	6.79	37.4	6.82	38.4	6.89	39.4	6.95
	29	27.2	4.72	32.3	6.09	35.9	7.02	36.4	7.07	36.9	7.10	37.8	7.17	38.9	7.23
	31	27.2	5.04	32.3	6.50	35.3	7.31	35.9	7.34	36.4	7.38	37.3	7.45	38.3	7.53
	33	27.2	5.36	32.3	6.93	34.8	7.58	35.3	7.62	35.8	7.65	36.7	7.74	37.7	7.81
	35	27.2	5.71	32.3	7.39	34.2	7.85	34.7	7.90	35.3	7.94	36.3	8.02	37.2	8.11
	37	27.2	6.08	32.3	7.87	33.7	8.14	34.2	8.18	34.7	8.22	35.7	8.30	36.6	8.40
	39	27.2	6.47	32.2	8.32	33.1	8.41	33.6	8.46	34.1	8.50	35.2	8.60	36.1	8.68
	41	27.2	6.64	31.9	8.37	32.9	8.47	33.4	8.52	33.8	8.56	34.9	8.62	35.1	8.75
43	27.2	6.74	31.8	8.43	32.6	8.52	33.1	8.55	33.6	8.59	34.3	8.65	34.5	8.92	
45	27.2	6.82	31.6	8.51	32.3	8.60	32.8	8.63	33.3	8.66	33.6	8.67	34.2	9.12	
48	27.2	6.88	31.3	8.61	31.9	8.68	32.2	8.70	32.9	8.73	33.1	8.70	33.8	9.23	

**Abbreviations:**

CR: Combination ratio

TC: Total capacity (kW)

PI: Power input (compressor + outdoor fan motor) (kW)

**Notes:**

1. Shaded cells indicate rating condition.

Table continued on next page ...

Table 2-8.3: VMEX010Q8A-D20V335 cooling capacity (continued)

CR	Outdoor air temp. (°C DB)	Indoor air temp. (°C DB / °C WB)													
		20.8 / 14.0		23.3 / 16.0		25.8 / 18.0		27.0 / 19.0		28.2 / 20.0		30.7 / 22.0		32.0 / 24.0	
		TC	PI	TC	PI	TC	PI	TC	PI	TC	PI	TC	PI	TC	PI
		kW	kW	kW	kW	kW	kW	kW	kW	kW	kW	kW	kW	kW	kW
110%	-5	24.9	2.69	29.7	3.34	34.5	3.99	36.9	4.28	39.2	4.61	42.2	4.79	43.2	4.93
	-2	24.9	2.74	29.7	3.39	34.5	4.02	36.9	4.33	39.2	4.64	42.2	4.83	43.2	4.96
	0	24.9	2.76	29.7	3.41	34.5	4.05	36.9	4.35	39.2	4.70	42.2	4.88	43.2	5.02
	2	24.9	2.83	29.7	3.44	34.5	4.12	36.9	4.40	39.2	4.75	42.2	4.95	43.2	5.08
	4	24.9	2.88	29.7	3.48	34.5	4.16	36.9	4.45	39.2	4.82	42.2	5.02	43.2	5.13
	6	24.9	2.91	29.7	3.52	34.5	4.20	36.9	4.53	39.2	4.87	42.2	5.07	43.2	5.21
	8	24.9	2.94	29.7	3.57	34.5	4.24	36.9	4.57	39.2	4.93	42.2	5.11	43.2	5.26
	10	24.9	2.97	29.7	3.62	34.5	4.31	36.9	4.65	39.2	5.01	42.2	5.14	43.2	5.31
	12	24.9	3.03	29.7	3.70	34.5	4.39	36.9	4.75	39.2	5.10	41.8	5.22	42.6	5.38
	14	24.9	3.09	29.7	3.76	34.5	4.47	36.9	4.83	39.2	5.20	41.2	5.26	42.1	5.42
	16	24.9	3.14	29.7	3.83	34.5	4.56	36.9	4.92	39.2	5.30	40.7	5.32	41.5	5.47
	18	24.9	3.20	29.7	3.91	34.5	4.65	36.9	5.06	39.2	5.55	40.1	5.60	41.0	5.65
	20	24.9	3.27	29.7	3.99	34.5	4.92	36.9	5.44	38.6	5.83	39.6	5.87	40.4	5.92
	21	24.9	3.30	29.7	4.11	34.5	5.10	36.9	5.64	38.4	5.96	39.2	6.01	40.2	6.06
	23	24.9	3.45	29.7	4.40	34.5	5.47	36.9	6.05	37.8	6.23	38.8	6.29	39.6	6.34
	25	24.9	3.69	29.7	4.70	34.5	5.85	36.9	6.48	37.3	6.50	38.2	6.56	39.1	6.61
	27	24.9	3.93	29.7	5.03	34.5	6.26	36.3	6.75	36.7	6.77	37.7	6.84	38.5	6.90
	29	24.9	4.19	29.7	5.37	34.5	6.69	35.8	7.02	36.3	7.06	37.1	7.12	38.0	7.18
	31	24.9	4.46	29.7	5.72	34.5	7.14	35.2	7.30	35.7	7.33	36.6	7.39	37.4	7.46
	33	24.9	4.75	29.7	6.10	34.2	7.53	34.7	7.57	35.2	7.60	36.0	7.68	37.0	7.75
35	24.9	5.05	29.7	6.50	33.6	7.80	34.1	7.84	34.6	7.89	35.4	7.96	36.4	8.03	
37	24.9	5.38	29.7	6.92	33.1	8.08	33.6	8.12	34.0	8.16	34.9	8.24	35.8	8.32	
39	24.9	5.71	29.7	7.37	32.5	8.36	33.0	8.40	33.5	8.44	34.3	8.53	35.3	8.61	
41	24.9	5.77	29.7	7.43	32.3	8.42	32.8	8.46	33.2	8.50	33.9	8.58	34.2	8.67	
43	24.9	5.83	29.7	7.53	32.0	8.48	32.5	8.52	33.0	8.56	33.6	8.62	33.7	8.84	
45	24.9	6.02	29.7	7.57	31.7	8.55	32.2	8.62	32.7	8.64	33.3	8.85	33.4	9.05	
48	24.9	6.23	29.7	8.21	31.2	8.61	31.7	8.68	32.3	8.73	32.7	8.88	33.0	9.15	
100%	-5	22.6	2.45	26.9	2.94	31.3	3.51	33.5	3.75	35.7	4.07	40.1	4.64	42.4	4.85
	-2	22.6	2.48	26.9	2.98	31.3	3.54	33.5	3.82	35.7	4.13	40.1	4.70	42.4	4.88
	0	22.6	2.50	26.9	3.01	31.3	3.58	33.5	3.87	35.7	4.17	40.1	4.78	42.4	4.93
	2	22.6	2.55	26.9	3.06	31.3	3.62	33.5	3.92	35.7	4.21	40.1	4.85	42.4	5.01
	4	22.6	2.57	26.9	3.08	31.3	3.68	33.5	3.98	35.7	4.27	40.1	4.89	42.4	5.06
	6	22.6	2.61	26.9	3.15	31.3	3.72	33.5	4.05	35.7	4.33	40.1	4.96	42.4	5.14
	8	22.6	2.66	26.9	3.19	31.3	3.79	33.5	4.10	35.7	4.40	40.1	5.04	42.4	5.23
	10	22.6	2.69	26.9	3.25	31.3	3.85	33.5	4.17	35.7	4.48	40.1	5.12	42.4	5.30
	12	22.6	2.73	26.9	3.32	31.3	3.93	33.5	4.24	35.7	4.57	40.1	5.22	41.8	5.34
	14	22.6	2.78	26.9	3.38	31.3	4.00	33.5	4.33	35.7	4.65	40.1	5.32	41.3	5.41
	16	22.6	2.83	26.9	3.44	31.3	4.08	33.5	4.41	35.7	4.75	39.8	5.39	40.7	5.47
	18	22.6	2.89	26.9	3.51	31.3	4.16	33.5	4.49	35.7	4.84	39.4	5.56	40.2	5.61
	20	22.6	2.94	26.9	3.58	31.3	4.28	33.5	4.72	35.7	5.19	38.8	5.83	39.6	5.88
	21	22.6	2.97	26.9	3.61	31.3	4.44	33.5	4.89	35.7	5.36	38.5	5.96	39.4	6.02
	23	22.6	3.04	26.9	3.85	31.3	4.76	33.5	5.24	35.7	5.75	38.0	6.24	38.8	6.29
	25	22.6	3.24	26.9	4.12	31.3	5.09	33.5	5.62	35.7	6.16	37.4	6.51	38.3	6.56
	27	22.6	3.46	26.9	4.39	31.3	5.44	33.5	6.01	35.7	6.59	36.9	6.78	37.7	6.85
	29	22.6	3.68	26.9	4.68	31.3	5.81	33.5	6.42	35.5	7.00	36.4	7.07	37.2	7.12
	31	22.6	3.93	26.9	5.00	31.3	6.19	33.5	6.85	35.1	7.28	35.8	7.34	36.6	7.40
	33	22.6	4.17	26.9	5.32	31.3	6.60	33.5	7.31	34.5	7.55	35.3	7.61	36.1	7.68
35	22.6	4.43	26.9	5.66	31.3	7.04	<b>33.5</b>	<b>7.79</b>	33.9	7.82	34.7	7.89	35.5	7.96	
37	22.6	4.71	26.9	6.03	31.3	7.51	32.9	8.06	33.4	8.10	34.2	8.18	34.9	8.24	
39	22.6	5.01	26.9	6.40	31.3	7.99	32.4	8.34	32.8	8.38	33.6	8.45	34.5	8.54	
41	22.6	5.24	26.9	6.64	31.3	8.28	31.9	8.39	32.5	8.51	33.0	8.65	34.0	8.71	
43	22.6	5.47	26.9	6.87	31.3	8.44	31.4	8.49	32.3	8.59	33.2	8.71	33.4	8.81	
45	22.6	5.79	26.9	7.18	31.3	8.58	30.7	8.61	32.1	8.74	33.0	8.84	32.7	8.93	
48	22.6	6.04	26.9	7.43	31.3	8.59	29.5	8.71	32.1	8.90	30.9	8.93	32.0	9.01	

Abbreviations:

CR: Combination ratio

TC: Total capacity (kW)

PI: Power input (compressor + outdoor fan motor) (kW)

Notes:

1. Shaded cells indicate rating condition.

Table continued on next page ...

# VMEX 460V 60Hz

Table 2-8.3: VMEX010Q8A-D20V335 cooling capacity (continued)

CR	Outdoor air temp. (°C DB)	Indoor air temp. (°C DB / °C WB)													
		20.8 / 14.0		23.3 / 16.0		25.8 / 18.0		27.0 / 19.0		28.2 / 20.0		30.7 / 22.0		32.0 / 24.0	
		TC	PI	TC	PI	TC	PI	TC	PI	TC	PI	TC	PI	TC	PI
		kW	kW	kW	kW	kW	kW	kW	kW	kW	kW	kW	kW	kW	kW
90%	-5	20.3	2.16	24.3	2.60	28.2	3.06	30.2	3.34	32.1	3.55	36.0	4.09	40.0	4.68
	-2	20.3	2.18	24.3	2.62	28.2	3.10	30.2	3.39	32.1	3.60	36.0	4.13	40.0	4.73
	0	20.3	2.22	24.3	2.66	28.2	3.15	30.2	3.43	32.1	3.64	36.0	4.17	40.0	4.76
	2	20.3	2.25	24.3	2.69	28.2	3.18	30.2	3.48	32.1	3.70	36.0	4.26	40.0	4.83
	4	20.3	2.28	24.3	2.73	28.2	3.23	30.2	3.53	32.1	3.75	36.0	4.33	40.0	4.90
	6	20.3	2.31	24.3	2.78	28.2	3.29	30.2	3.59	32.1	3.81	36.0	4.39	40.0	4.99
	8	20.3	2.36	24.3	2.84	28.2	3.36	30.2	3.64	32.1	3.88	36.0	4.47	40.0	5.03
	10	20.3	2.40	24.3	2.90	28.2	3.42	30.2	3.70	32.1	3.97	36.0	4.53	40.0	5.11
	12	20.3	2.45	24.3	2.95	28.2	3.49	30.2	3.76	32.1	4.04	36.0	4.62	40.0	5.21
	14	20.3	2.49	24.3	3.00	28.2	3.55	30.2	3.83	32.1	4.12	36.0	4.70	40.0	5.30
	16	20.3	2.53	24.3	3.06	28.2	3.62	30.2	3.91	32.1	4.20	36.0	4.80	39.8	5.40
	18	20.3	2.57	24.3	3.12	28.2	3.68	30.2	3.98	32.1	4.28	36.0	4.89	39.4	5.56
	20	20.3	2.62	24.3	3.19	28.2	3.76	30.2	4.06	32.1	4.44	36.0	5.26	38.8	5.83
	21	20.3	2.65	24.3	3.21	28.2	3.82	30.2	4.20	32.1	4.60	36.0	5.45	38.5	5.96
	23	20.3	2.70	24.3	3.34	28.2	4.09	30.2	4.50	32.1	4.93	36.0	5.85	37.9	6.24
	25	20.3	2.84	24.3	3.57	28.2	4.38	30.2	4.82	32.1	5.27	36.0	6.26	37.4	6.51
	27	20.3	3.02	24.3	3.80	28.2	4.67	30.2	5.14	32.1	5.64	36.0	6.70	36.8	6.78
	29	20.3	3.22	24.3	4.05	28.2	4.99	30.2	5.49	32.1	6.03	35.7	7.00	36.4	7.05
	31	20.3	3.42	24.3	4.31	28.2	5.31	30.2	5.86	32.1	6.42	35.1	7.28	35.8	7.34
	33	20.3	3.63	24.3	4.59	28.2	5.67	30.2	6.25	32.1	6.86	34.6	7.56	35.3	7.61
35	20.3	3.86	24.3	4.88	28.2	6.04	30.2	6.66	32.1	7.31	34.0	7.83	34.7	7.89	
37	20.3	4.09	24.3	5.19	28.2	6.42	30.2	7.09	32.1	7.79	33.4	8.10	34.2	8.17	
39	20.3	4.35	24.3	5.52	28.2	6.83	30.2	7.55	32.1	8.29	32.9	8.39	33.6	8.45	
41	20.3	4.50	24.3	5.77	28.2	7.08	30.2	7.75	32.1	8.34	32.7	8.60	33.4	8.65	
43	20.3	4.71	24.3	6.02	28.2	7.33	30.2	7.95	32.1	8.52	32.5	8.71	33.1	8.78	
45	20.3	5.01	24.3	6.32	28.2	7.63	30.2	8.21	32.1	8.76	32.3	8.80	32.6	8.90	
48	20.3	5.29	24.3	6.61	28.2	7.92	30.2	8.32	32.1	8.83	32.1	8.93	31.7	9.02	
80%	-5	18.1	1.91	21.5	2.25	25.0	2.67	26.8	2.84	28.6	3.06	32.1	3.53	35.5	4.03
	-2	18.1	1.93	21.5	2.28	25.0	2.69	26.8	2.88	28.6	3.08	32.1	3.57	35.5	4.07
	0	18.1	1.97	21.5	2.31	25.0	2.72	26.8	2.92	28.6	3.14	32.1	3.62	35.5	4.13
	2	18.1	2.01	21.5	2.34	25.0	2.76	26.8	2.97	28.6	3.20	32.1	3.69	35.5	4.20
	4	18.1	2.04	21.5	2.38	25.0	2.82	26.8	3.04	28.6	3.25	32.1	3.76	35.5	4.26
	6	18.1	2.07	21.5	2.44	25.0	2.86	26.8	3.11	28.6	3.31	32.1	3.81	35.5	4.33
	8	18.1	2.11	21.5	2.49	25.0	2.93	26.8	3.16	28.6	3.39	32.1	3.87	35.5	4.42
	10	18.1	2.13	21.5	2.55	25.0	3.00	26.8	3.23	28.6	3.46	32.1	3.96	35.5	4.46
	12	18.1	2.16	21.5	2.59	25.0	3.05	26.8	3.30	28.6	3.54	32.1	4.03	35.5	4.55
	14	18.1	2.21	21.5	2.65	25.0	3.11	26.8	3.35	28.6	3.60	32.1	4.11	35.5	4.63
	16	18.1	2.24	21.5	2.69	25.0	3.17	26.8	3.41	28.6	3.66	32.1	4.19	35.5	4.71
	18	18.1	2.28	21.5	2.74	25.0	3.23	26.8	3.49	28.6	3.74	32.1	4.27	35.5	4.81
	20	18.1	2.32	21.5	2.79	25.0	3.30	26.8	3.55	28.6	3.81	32.1	4.43	35.5	5.14
	21	18.1	2.34	21.5	2.81	25.0	3.33	26.8	3.59	28.6	3.90	32.1	4.59	35.5	5.33
	23	18.1	2.38	21.5	2.88	25.0	3.49	26.8	3.82	28.6	4.17	32.1	4.91	35.5	5.72
	25	18.1	2.46	21.5	3.05	25.0	3.73	26.8	4.08	28.6	4.45	32.1	5.26	35.5	6.12
	27	18.1	2.61	21.5	3.25	25.0	3.97	26.8	4.36	28.6	4.76	32.1	5.62	35.5	6.55
	29	18.1	2.78	21.5	3.46	25.0	4.23	26.8	4.64	28.6	5.08	32.1	5.99	35.5	7.00
	31	18.1	2.95	21.5	3.69	25.0	4.50	26.8	4.94	28.6	5.42	32.1	6.40	34.9	7.28
	33	18.1	3.14	21.5	3.92	25.0	4.80	26.8	5.27	28.6	5.76	32.1	6.82	34.5	7.55
35	18.1	3.33	21.5	4.17	25.0	5.10	26.8	5.61	28.6	6.14	32.1	7.28	33.9	7.82	
37	18.1	3.53	21.5	4.42	25.0	5.43	26.8	5.97	28.6	6.54	32.1	7.76	33.4	8.09	
39	18.1	3.74	21.5	4.71	25.0	5.77	26.8	6.35	28.6	6.96	32.1	8.26	32.8	8.38	
41	18.1	3.82	21.5	4.76	25.0	5.86	26.8	6.52	28.6	7.09	32.1	8.47	32.6	8.53	
43	18.1	3.93	21.5	4.80	25.0	5.94	26.8	6.63	28.6	7.19	32.1	8.57	32.4	8.62	
45	18.1	4.05	21.5	4.85	25.0	6.06	26.8	6.77	28.6	7.31	32.1	8.67	32.0	8.76	
48	18.1	4.18	21.5	4.89	25.0	6.15	26.8	6.86	28.6	7.37	32.1	8.75	31.7	8.88	

Abbreviations:

CR: Combination ratio

TC: Total capacity (kW)

PI: Power input (compressor + outdoor fan motor) (kW)

Notes:

1. Shaded cells indicate rating condition.

Table continued on next page ...



Table 2-8.3: VMEX010Q8A-D20V335 cooling capacity (continued)

CR	Outdoor air temp. (°C DB)	Indoor air temp. (°C DB / °C WB)													
		20.8 / 14.0		23.3 / 16.0		25.8 / 18.0		27.0 / 19.0		28.2 / 20.0		30.7 / 22.0		32.0 / 24.0	
		TC	PI	TC	PI	TC	PI	TC	PI	TC	PI	TC	PI	TC	PI
		kW	kW	kW	kW	kW	kW	kW	kW	kW	kW	kW	kW	kW	kW
70%	-5	15.8	1.70	18.9	2.00	21.9	2.26	23.5	2.42	25.0	2.59	28.0	2.96	31.1	3.40
	-2	15.8	1.72	18.9	2.00	21.9	2.27	23.5	2.47	25.0	2.63	28.0	3.01	31.1	3.45
	0	15.8	1.72	18.9	2.03	21.9	2.32	23.5	2.52	25.0	2.68	28.0	3.07	31.1	3.50
	2	15.8	1.73	18.9	2.04	21.9	2.36	23.5	2.56	25.0	2.73	28.0	3.13	31.1	3.55
	4	15.8	1.76	18.9	2.09	21.9	2.41	23.5	2.61	25.0	2.79	28.0	3.18	31.1	3.64
	6	15.8	1.79	18.9	2.13	21.9	2.47	23.5	2.69	25.0	2.85	28.0	3.24	31.1	3.71
	8	15.8	1.82	18.9	2.19	21.9	2.53	23.5	2.74	25.0	2.91	28.0	3.33	31.1	3.78
	10	15.8	1.86	18.9	2.23	21.9	2.59	23.5	2.79	25.0	2.99	28.0	3.40	31.1	3.82
	12	15.8	1.90	18.9	2.26	21.9	2.65	23.5	2.85	25.0	3.04	28.0	3.46	31.1	3.90
	14	15.8	1.93	18.9	2.30	21.9	2.69	23.5	2.89	25.0	3.10	28.0	3.53	31.1	3.97
	16	15.8	1.96	18.9	2.34	21.9	2.74	23.5	2.95	25.0	3.16	28.0	3.59	31.1	4.04
	18	15.8	1.99	18.9	2.38	21.9	2.79	23.5	3.00	25.0	3.21	28.0	3.66	31.1	4.13
	20	15.8	2.03	18.9	2.43	21.9	2.85	23.5	3.06	25.0	3.28	28.0	3.74	31.1	4.24
	21	15.8	2.05	18.9	2.45	21.9	2.87	23.5	3.09	25.0	3.31	28.0	3.79	31.1	4.39
	23	15.8	2.08	18.9	2.49	21.9	2.93	23.5	3.19	25.0	3.48	28.0	4.06	31.1	4.70
	25	15.8	2.12	18.9	2.59	21.9	3.12	23.5	3.41	25.0	3.71	28.0	4.35	31.1	5.03
	27	15.8	2.25	18.9	2.76	21.9	3.33	23.5	3.63	25.0	3.96	28.0	4.64	31.1	5.38
	29	15.8	2.38	18.9	2.93	21.9	3.54	23.5	3.87	25.0	4.21	28.0	4.94	31.1	5.74
	31	15.8	2.52	18.9	3.11	21.9	3.77	23.5	4.12	25.0	4.48	28.0	5.27	31.1	6.12
	33	15.8	2.68	18.9	3.31	21.9	4.01	23.5	4.38	25.0	4.78	28.0	5.62	31.1	6.53
35	15.8	2.83	18.9	3.51	21.9	4.25	23.5	4.66	25.0	5.08	28.0	5.98	31.1	6.96	
37	15.8	2.99	18.9	3.72	21.9	4.52	23.5	4.94	25.0	5.41	28.0	6.37	31.1	7.41	
39	15.8	3.17	18.9	3.94	21.9	4.80	23.5	5.26	25.0	5.74	28.0	6.77	31.1	7.90	
41	15.8	3.31	18.9	4.08	21.9	4.94	23.5	5.43	25.0	5.92	28.0	7.05	31.1	8.24	
43	15.8	3.58	18.9	4.36	21.9	5.14	23.5	5.73	25.0	6.09	28.0	7.31	31.1	8.50	
45	15.8	3.66	18.9	4.45	21.9	5.25	23.5	5.82	25.0	6.40	28.0	7.70	31.1	8.83	
48	15.8	3.75	18.9	4.49	21.9	5.30	23.5	5.91	25.0	6.57	28.0	8.05	31.1	9.04	
60%	-5	13.5	1.45	16.2	1.68	18.8	1.96	20.1	2.09	21.4	2.26	24.0	2.53	26.7	2.91
	-2	13.5	1.46	16.2	1.71	18.8	2.00	20.1	2.12	21.4	2.28	24.0	2.57	26.7	2.93
	0	13.5	1.48	16.2	1.73	18.8	2.02	20.1	2.15	21.4	2.32	24.0	2.61	26.7	2.96
	2	13.5	1.51	16.2	1.77	18.8	2.06	20.1	2.19	21.4	2.35	24.0	2.66	26.7	3.00
	4	13.5	1.55	16.2	1.80	18.8	2.10	20.1	2.22	21.4	2.38	24.0	2.71	26.7	3.04
	6	13.5	1.57	16.2	1.84	18.8	2.14	20.1	2.26	21.4	2.43	24.0	2.76	26.7	3.12
	8	13.5	1.60	16.2	1.87	18.8	2.18	20.1	2.31	21.4	2.48	24.0	2.81	26.7	3.17
	10	13.5	1.63	16.2	1.91	18.8	2.21	20.1	2.37	21.4	2.53	24.0	2.87	26.7	3.21
	12	13.5	1.66	16.2	1.94	18.8	2.26	20.1	2.41	21.4	2.57	24.0	2.92	26.7	3.26
	14	13.5	1.68	16.2	1.97	18.8	2.29	20.1	2.46	21.4	2.62	24.0	2.97	26.7	3.33
	16	13.5	1.70	16.2	2.00	18.8	2.33	20.1	2.50	21.4	2.67	24.0	3.02	26.7	3.39
	18	13.5	1.73	16.2	2.04	18.8	2.37	20.1	2.54	21.4	2.72	24.0	3.08	26.7	3.45
	20	13.5	1.75	16.2	2.08	18.8	2.41	20.1	2.59	21.4	2.77	24.0	3.14	26.7	3.53
	21	13.5	1.77	16.2	2.09	18.8	2.44	20.1	2.61	21.4	2.79	24.0	3.17	26.7	3.56
	23	13.5	1.80	16.2	2.13	18.8	2.48	20.1	2.67	21.4	2.84	24.0	3.30	26.7	3.79
	25	13.5	1.83	16.2	2.16	18.8	2.57	20.1	2.79	21.4	3.02	24.0	3.52	26.7	4.04
	27	13.5	1.90	16.2	2.30	18.8	2.74	20.1	2.98	21.4	3.22	24.0	3.75	26.7	4.31
	29	13.5	2.00	16.2	2.44	18.8	2.92	20.1	3.17	21.4	3.43	24.0	4.00	26.7	4.61
	31	13.5	2.13	16.2	2.58	18.8	3.10	20.1	3.37	21.4	3.65	24.0	4.25	26.7	4.90
	33	13.5	2.25	16.2	2.74	18.8	3.29	20.1	3.58	21.4	3.88	24.0	4.52	26.7	5.23
35	13.5	2.38	16.2	2.91	18.8	3.48	20.1	3.80	21.4	4.13	24.0	4.82	26.7	5.56	
37	13.5	2.52	16.2	3.08	18.8	3.70	20.1	4.03	21.4	4.38	24.0	5.12	26.7	5.92	
39	13.5	2.66	16.2	3.25	18.8	3.92	20.1	4.27	21.4	4.65	24.0	5.44	26.7	6.30	
41	13.5	2.74	16.2	3.39	18.8	4.06	20.1	4.44	21.4	4.82	24.0	5.69	26.7	6.58	
43	13.5	2.83	16.2	3.54	18.8	4.20	20.1	4.58	21.4	4.99	24.0	5.94	26.7	6.87	
45	13.5	2.96	16.2	3.72	18.8	4.37	20.1	4.75	21.4	5.24	24.0	6.20	26.7	7.25	
48	13.5	3.07	16.2	3.88	18.8	4.52	20.1	4.87	21.4	5.44	24.0	6.43	26.7	7.59	

Abbreviations:

CR: Combination ratio

TC: Total capacity (kW)

PI: Power input (compressor + outdoor fan motor) (kW)

Notes:

1. Shaded cells indicate rating condition.

Table continued on next page ...

# VMEX 460V 60Hz

Table 2-8.3: VMEX010Q8A-D20V335 cooling capacity (continued)

CR	Outdoor air temp. (°C DB)	Indoor air temp. (°C DB / °C WB)													
		20.8 / 14.0		23.3 / 16.0		25.8 / 18.0		27.0 / 19.0		28.2 / 20.0		30.7 / 22.0		32.0 / 24.0	
		TC	PI	TC	PI	TC	PI	TC	PI	TC	PI	TC	PI	TC	PI
		kW	kW	kW	kW	kW	kW	kW	kW	kW	kW	kW	kW	kW	kW
50%	-5	11.3	1.26	13.5	1.46	15.7	1.67	16.8	1.75	17.8	1.85	20.0	2.10	22.3	2.27
	-2	11.3	1.27	13.5	1.49	15.7	1.69	16.8	1.78	17.8	1.88	20.0	2.13	22.3	2.30
	0	11.3	1.29	13.5	1.51	15.7	1.72	16.8	1.80	17.8	1.90	20.0	2.17	22.3	2.34
	2	11.3	1.31	13.5	1.53	15.7	1.75	16.8	1.83	17.8	1.94	20.0	2.18	22.3	2.38
	4	11.3	1.32	13.5	1.56	15.7	1.77	16.8	1.85	17.8	1.98	20.0	2.23	22.3	2.44
	6	11.3	1.35	13.5	1.58	15.7	1.80	16.8	1.89	17.8	2.01	20.0	2.27	22.3	2.52
	8	11.3	1.38	13.5	1.61	15.7	1.83	16.8	1.93	17.8	2.04	20.0	2.30	22.3	2.60
	10	11.3	1.41	13.5	1.63	15.7	1.86	16.8	1.97	17.8	2.10	20.0	2.36	22.3	2.63
	12	11.3	1.42	13.5	1.65	15.7	1.89	16.8	2.01	17.8	2.14	20.0	2.40	22.3	2.68
	14	11.3	1.44	13.5	1.67	15.7	1.91	16.8	2.05	17.8	2.17	20.0	2.45	22.3	2.73
	16	11.3	1.46	13.5	1.69	15.7	1.94	16.8	2.08	17.8	2.20	20.0	2.49	22.3	2.77
	18	11.3	1.48	13.5	1.72	15.7	1.97	16.8	2.11	17.8	2.25	20.0	2.53	22.3	2.82
	20	11.3	1.50	13.5	1.74	15.7	2.01	16.8	2.14	17.8	2.29	20.0	2.57	22.3	2.88
	21	11.3	1.51	13.5	1.76	15.7	2.03	16.8	2.16	17.8	2.31	20.0	2.60	22.3	2.91
	23	11.3	1.53	13.5	1.78	15.7	2.06	16.8	2.20	17.8	2.35	20.0	2.65	22.3	2.97
	25	11.3	1.55	13.5	1.82	15.7	2.10	16.8	2.25	17.8	2.42	20.0	2.78	22.3	3.17
	27	11.3	1.59	13.5	1.89	15.7	2.21	16.8	2.39	17.8	2.57	20.0	2.96	22.3	3.38
	29	11.3	1.67	13.5	1.99	15.7	2.35	16.8	2.54	17.8	2.74	20.0	3.15	22.3	3.60
	31	11.3	1.76	13.5	2.11	15.7	2.49	16.8	2.70	17.8	2.91	20.0	3.35	22.3	3.83
	33	11.3	1.87	13.5	2.24	15.7	2.65	16.8	2.86	17.8	3.09	20.0	3.56	22.3	4.07
35	11.3	1.97	13.5	2.36	15.7	2.79	16.8	3.02	17.8	3.27	20.0	3.78	22.3	4.33	
37	11.3	2.08	13.5	2.50	15.7	2.96	16.8	3.20	17.8	3.46	20.0	4.01	22.3	4.60	
39	11.3	2.19	13.5	2.63	15.7	3.13	16.8	3.39	17.8	3.67	20.0	4.25	22.3	4.88	
41	11.3	2.28	13.5	2.75	15.7	3.24	16.8	3.55	17.8	3.83	20.0	4.48	22.3	5.11	
43	11.3	2.44	13.5	2.94	15.7	3.35	16.8	3.71	17.8	3.93	20.0	4.71	22.3	5.33	
45	11.3	2.49	13.5	3.01	15.7	3.58	16.8	4.00	17.8	4.10	20.0	5.16	22.3	5.79	
48	11.3	2.55	13.5	3.10	15.7	3.79	16.8	4.25	17.8	4.28	20.0	5.57	22.3	6.23	

Abbreviations:

CR: Combination ratio

TC: Total capacity (kW)

PI: Power input (compressor + outdoor fan motor) (kW)

Notes:

1. Shaded cells indicate rating condition.

Table 2-8.4: VMEX012Q8A-D23V400 cooling capacity

CR	Outdoor air temp. (°C DB)	Indoor air temp. (°C DB / °C WB)													
		20.8 / 14.0		23.3 / 16.0		25.8 / 18.0		27.0 / 19.0		28.2 / 20.0		30.7 / 22.0		32.0 / 24.0	
		TC	PI	TC	PI	TC	PI	TC	PI	TC	PI	TC	PI	TC	PI
		kW	kW	kW	kW	kW	kW	kW	kW	kW	kW	kW	kW	kW	kW
130%	-5	35.1	3.80	41.9	4.64	48.6	4.97	50.4	5.18	52.9	5.32	54.1	5.79	55.5	5.83
	-2	35.1	3.80	41.9	4.73	48.6	4.97	50.4	5.21	52.9	5.32	54.1	5.86	55.5	5.88
	0	35.1	3.87	41.9	4.81	48.6	5.16	50.4	5.49	52.9	5.63	54.1	5.93	55.5	5.96
	2	35.1	3.94	41.9	4.82	48.6	5.33	50.4	5.80	52.9	5.70	54.1	5.98	55.5	6.05
	4	35.1	4.02	41.9	4.92	48.6	5.52	50.4	5.83	52.9	5.77	54.1	6.07	55.5	6.17
	6	35.1	4.10	41.9	5.01	48.6	5.72	50.4	5.87	52.3	5.95	53.5	6.16	54.9	6.21
	8	35.1	4.20	41.9	5.13	48.6	6.01	50.4	6.16	51.6	6.14	52.9	6.18	54.2	6.27
	10	35.1	4.29	41.9	5.24	48.6	6.23	50.4	6.37	51.0	6.26	52.3	6.28	53.6	6.45
	12	35.1	4.36	41.9	5.34	48.6	6.35	49.7	6.46	50.4	6.35	51.6	6.37	52.9	6.49
	14	35.1	4.45	41.9	5.44	48.4	6.45	49.1	6.56	49.7	6.45	51.0	6.47	52.3	6.64
	16	35.1	4.53	41.9	5.55	47.9	6.54	48.4	6.64	49.0	6.64	50.3	6.56	51.6	6.74
	18	35.1	4.61	41.9	5.67	47.1	6.64	47.7	6.68	48.4	6.72	49.7	6.78	51.0	6.84
	20	35.1	4.71	41.9	6.03	46.4	6.97	47.1	7.01	47.7	7.04	49.0	7.11	50.3	7.18
	21	35.1	4.84	41.9	6.24	46.1	7.13	46.9	7.17	47.4	7.21	48.7	7.28	50.0	7.35
	23	35.1	5.19	41.9	6.69	45.6	7.46	46.1	7.50	46.7	7.53	48.0	7.61	49.3	7.68
	25	35.1	5.54	41.9	7.17	44.9	7.78	45.4	7.82	46.1	7.87	47.4	7.95	48.7	8.02
	27	35.1	5.92	41.9	7.67	44.3	8.11	44.9	8.16	45.4	8.20	46.7	8.29	48.0	8.37
	29	35.1	6.32	41.9	8.20	43.6	8.44	44.1	8.49	44.9	8.54	46.1	8.62	47.4	8.71
	31	35.1	6.74	41.7	8.67	42.9	8.77	43.6	8.82	44.1	8.86	45.4	8.96	46.7	9.06
	33	35.1	7.18	41.0	9.00	42.3	9.10	42.9	9.15	43.6	9.20	44.9	9.30	46.0	9.40
35	35.1	7.66	40.3	9.33	41.6	9.44	42.3	9.49	42.9	9.54	44.1	9.65	45.4	9.75	
37	35.1	8.15	39.7	9.66	41.0	9.78	41.6	9.83	42.3	9.89	43.4	10.00	44.7	10.12	
39	35.1	8.67	39.0	9.76	40.3	10.10	41.0	10.17	41.6	10.23	42.9	10.34	44.1	10.47	
41	35.1	9.13	38.6	9.86	39.9	10.20	40.6	10.26	41.1	10.32	42.4	10.36	42.4	10.56	
43	35.1	9.36	38.3	9.91	39.6	10.23	40.4	10.31	40.7	10.34	41.7	10.38	41.9	10.58	
45	35.1	9.83	38.1	10.00	39.2	10.32	39.9	10.37	40.1	10.38	40.5	10.42	41.1	10.78	
48	35.1	10.18	38.0	10.33	38.6	10.42	39.3	10.47	39.6	10.50	39.5	10.60	40.2	10.82	
120%	-5	32.4	3.67	38.6	4.45	44.9	5.26	48.0	5.74	50.3	5.98	51.4	6.17	52.6	6.33
	-2	32.4	3.71	38.6	4.49	44.9	5.31	48.0	5.77	50.3	6.05	51.4	6.22	52.6	6.36
	0	32.4	3.74	38.6	4.52	44.9	5.37	48.0	5.78	50.3	6.10	51.4	6.26	52.6	6.37
	2	32.4	3.75	38.6	4.57	44.9	5.41	48.0	5.84	50.3	6.13	51.4	6.30	52.6	6.38
	4	32.4	3.79	38.6	4.63	44.9	5.49	48.0	5.89	50.3	6.21	51.4	6.32	52.6	6.40
	6	32.4	3.83	38.6	4.67	44.9	5.55	48.0	5.96	50.3	6.28	51.4	6.37	52.6	6.42
	8	32.4	3.86	38.6	4.71	44.9	5.63	48.0	6.03	50.3	6.34	51.4	6.39	52.6	6.45
	10	32.4	3.91	38.6	4.77	44.9	5.68	48.0	6.14	50.3	6.34	51.4	6.41	52.6	6.48
	12	32.4	3.99	38.6	4.86	44.9	5.79	48.0	6.25	49.6	6.37	50.7	6.37	51.9	6.52
	14	32.4	4.06	38.6	4.96	44.9	5.90	48.0	6.38	48.9	6.41	50.1	6.47	51.3	6.60
	16	32.4	4.14	38.6	5.06	44.9	6.02	47.7	6.49	48.3	6.50	49.4	6.58	50.6	6.70
	18	32.4	4.21	38.6	5.16	44.9	6.22	47.0	6.64	47.6	6.67	48.7	6.73	50.0	6.79
	20	32.4	4.30	38.6	5.36	44.9	6.69	46.4	6.97	47.0	6.99	48.1	7.06	49.3	7.12
	21	32.4	4.34	38.6	5.55	44.9	6.93	46.0	7.13	46.6	7.16	47.9	7.22	49.0	7.29
	23	32.4	4.64	38.6	5.95	44.9	7.42	45.4	7.45	46.0	7.48	47.1	7.56	48.3	7.62
	25	32.4	4.95	38.6	6.37	44.1	7.75	44.7	7.77	45.3	7.81	46.6	7.88	47.7	7.96
	27	32.4	5.29	38.6	6.81	43.6	8.06	44.1	8.11	44.7	8.15	45.9	8.22	47.0	8.30
	29	32.4	5.64	38.6	7.27	42.9	8.38	43.4	8.43	44.0	8.47	45.1	8.56	46.4	8.64
	31	32.4	6.02	38.6	7.76	42.1	8.72	42.9	8.76	43.4	8.81	44.6	8.90	45.7	8.99
	33	32.4	6.40	38.6	8.27	41.6	9.05	42.1	9.10	42.7	9.14	43.9	9.24	45.0	9.33
35	32.4	6.82	38.6	8.82	40.9	9.37	41.4	9.43	42.1	9.48	43.3	9.58	44.4	9.68	
37	32.4	7.26	38.6	9.40	40.3	9.71	40.9	9.76	41.4	9.81	42.6	9.91	43.7	10.03	
39	32.4	7.72	38.4	9.93	39.6	10.04	40.1	10.10	40.7	10.15	42.0	10.27	43.1	10.37	
41	32.4	7.93	38.1	10.00	39.3	10.11	39.8	10.17	40.4	10.22	41.7	10.29	41.9	10.44	
43	32.4	8.05	37.9	10.07	39.0	10.17	39.5	10.21	40.1	10.26	41.0	10.32	41.3	10.65	
45	32.4	8.14	37.7	10.16	38.6	10.27	39.1	10.31	39.7	10.34	40.1	10.35	40.8	10.88	
48	32.4	8.21	37.4	10.27	38.1	10.36	38.5	10.38	39.3	10.42	39.5	10.39	40.3	11.02	

Abbreviations:

CR: Combination ratio

TC: Total capacity (kW)

PI: Power input (compressor + outdoor fan motor) (kW)

Notes:

1. Shaded cells indicate rating condition.

Table continued on next page ...

# VMEX 460V 60Hz

Table 2-8.4: VMEX012Q8A-D23V400 cooling capacity (continued)

CR	Outdoor air temp. (°C DB)	Indoor air temp. (°C DB / °C WB)													
		20.8 / 14.0		23.3 / 16.0		25.8 / 18.0		27.0 / 19.0		28.2 / 20.0		30.7 / 22.0		32.0 / 24.0	
		TC	PI	TC	PI	TC	PI	TC	PI	TC	PI	TC	PI	TC	PI
		kW	kW	kW	kW	kW	kW	kW	kW	kW	kW	kW	kW	kW	kW
110%	-5	29.7	3.21	35.4	3.99	41.1	4.76	44.0	5.11	46.9	5.50	50.4	5.71	51.6	5.89
	-2	29.7	3.27	35.4	4.04	41.1	4.80	44.0	5.16	46.9	5.54	50.4	5.77	51.6	5.92
	0	29.7	3.30	35.4	4.07	41.1	4.84	44.0	5.20	46.9	5.61	50.4	5.83	51.6	5.99
	2	29.7	3.37	35.4	4.10	41.1	4.92	44.0	5.25	46.9	5.67	50.4	5.91	51.6	6.07
	4	29.7	3.44	35.4	4.15	41.1	4.96	44.0	5.32	46.9	5.75	50.4	5.99	51.6	6.12
	6	29.7	3.47	35.4	4.20	41.1	5.01	44.0	5.40	46.9	5.82	50.4	6.06	51.6	6.22
	8	29.7	3.51	35.4	4.27	41.1	5.07	44.0	5.46	46.9	5.88	50.4	6.10	51.6	6.28
	10	29.7	3.55	35.4	4.32	41.1	5.14	44.0	5.55	46.9	5.98	50.4	6.14	51.6	6.34
	12	29.7	3.62	35.4	4.41	41.1	5.24	44.0	5.67	46.9	6.09	49.9	6.23	50.9	6.42
	14	29.7	3.69	35.4	4.49	41.1	5.34	44.0	5.77	46.9	6.21	49.1	6.28	50.3	6.47
	16	29.7	3.75	35.4	4.57	41.1	5.44	44.0	5.88	46.9	6.33	48.6	6.35	49.6	6.54
	18	29.7	3.82	35.4	4.66	41.1	5.55	44.0	6.04	46.9	6.63	47.9	6.68	49.0	6.74
	20	29.7	3.90	35.4	4.76	41.1	5.88	44.0	6.49	46.1	6.96	47.3	7.01	48.3	7.07
	21	29.7	3.94	35.4	4.90	41.1	6.09	44.0	6.73	45.9	7.12	46.9	7.17	48.0	7.23
	23	29.7	4.12	35.4	5.25	41.1	6.53	44.0	7.22	45.1	7.43	46.3	7.51	47.3	7.57
	25	29.7	4.40	35.4	5.62	41.1	6.98	44.0	7.73	44.6	7.76	45.6	7.83	46.7	7.90
	27	29.7	4.69	35.4	6.00	41.1	7.47	43.3	8.06	43.9	8.09	45.0	8.16	46.0	8.23
	29	29.7	5.00	35.4	6.41	41.1	7.98	42.7	8.39	43.3	8.42	44.3	8.50	45.4	8.57
	31	29.7	5.33	35.4	6.83	41.1	8.52	42.0	8.71	42.6	8.75	43.7	8.82	44.7	8.91
	33	29.7	5.67	35.4	7.28	40.9	8.99	41.4	9.04	42.0	9.07	43.0	9.16	44.1	9.25
35	29.7	6.03	35.4	7.76	40.1	9.31	40.7	9.36	41.3	9.41	42.3	9.50	43.4	9.59	
37	29.7	6.42	35.4	8.26	39.6	9.65	40.1	9.69	40.6	9.74	41.7	9.84	42.7	9.93	
39	29.7	6.82	35.4	8.80	38.9	9.98	39.4	10.03	40.0	10.08	41.0	10.18	42.1	10.28	
41	29.7	6.89	35.4	8.87	38.6	10.05	39.1	10.10	39.7	10.15	40.5	10.25	40.9	10.35	
43	29.7	6.96	35.4	8.98	38.2	10.12	38.8	10.17	39.4	10.22	40.1	10.29	40.2	10.56	
45	29.7	7.18	35.4	9.03	37.9	10.21	38.4	10.29	39.0	10.31	39.7	10.57	39.9	10.80	
48	29.7	7.44	35.4	9.80	37.3	10.28	37.8	10.36	38.6	10.42	39.1	10.61	39.4	10.92	
100%	-5	27.0	2.92	32.1	3.52	37.4	4.19	40.0	4.48	42.6	4.86	47.9	5.54	50.6	5.78
	-2	27.0	2.96	32.1	3.56	37.4	4.23	40.0	4.57	42.6	4.93	47.9	5.61	50.6	5.82
	0	27.0	2.99	32.1	3.60	37.4	4.28	40.0	4.62	42.6	4.98	47.9	5.70	50.6	5.89
	2	27.0	3.04	32.1	3.65	37.4	4.32	40.0	4.68	42.6	5.03	47.9	5.78	50.6	5.98
	4	27.0	3.07	32.1	3.68	37.4	4.39	40.0	4.75	42.6	5.10	47.9	5.84	50.6	6.05
	6	27.0	3.11	32.1	3.76	37.4	4.45	40.0	4.84	42.6	5.17	47.9	5.92	50.6	6.14
	8	27.0	3.17	32.1	3.81	37.4	4.53	40.0	4.89	42.6	5.25	47.9	6.02	50.6	6.24
	10	27.0	3.21	32.1	3.89	37.4	4.60	40.0	4.98	42.6	5.35	47.9	6.12	50.6	6.33
	12	27.0	3.26	32.1	3.96	37.4	4.69	40.0	5.06	42.6	5.45	47.9	6.23	49.9	6.38
	14	27.0	3.32	32.1	4.04	37.4	4.78	40.0	5.16	42.6	5.55	47.9	6.35	49.3	6.46
	16	27.0	3.38	32.1	4.11	37.4	4.88	40.0	5.26	42.6	5.67	47.6	6.43	48.6	6.53
	18	27.0	3.45	32.1	4.19	37.4	4.96	40.0	5.36	42.6	5.78	47.0	6.64	48.0	6.69
	20	27.0	3.51	32.1	4.27	37.4	5.11	40.0	5.64	42.6	6.19	46.3	6.96	47.3	7.02
	21	27.0	3.55	32.1	4.31	37.4	5.30	40.0	5.84	42.6	6.40	46.0	7.12	47.0	7.18
	23	27.0	3.63	32.1	4.60	37.4	5.68	40.0	6.25	42.6	6.87	45.4	7.44	46.3	7.51
	25	27.0	3.87	32.1	4.91	37.4	6.08	40.0	6.71	42.6	7.36	44.7	7.77	45.7	7.83
	27	27.0	4.14	32.1	5.24	37.4	6.49	40.0	7.17	42.6	7.87	44.0	8.10	45.0	8.17
	29	27.0	4.40	32.1	5.59	37.4	6.93	40.0	7.66	42.4	8.36	43.4	8.44	44.4	8.50
	31	27.0	4.69	32.1	5.97	37.4	7.39	40.0	8.17	41.9	8.69	42.7	8.76	43.7	8.84
	33	27.0	4.98	32.1	6.35	37.4	7.88	40.0	8.72	41.1	9.01	42.1	9.09	43.1	9.17
35	27.0	5.29	32.1	6.76	37.4	8.41	<b>40.0</b>	<b>9.30</b>	40.4	9.34	41.4	9.42	42.4	9.50	
37	27.0	5.63	32.1	7.19	37.4	8.96	39.3	9.63	39.9	9.68	40.9	9.76	41.7	9.84	
39	27.0	5.98	32.1	7.65	37.4	9.54	38.7	9.95	39.1	10.00	40.1	10.09	41.1	10.19	
41	27.0	6.26	32.1	7.92	37.4	9.89	38.1	10.02	38.8	10.16	39.4	10.33	40.5	10.40	
43	27.0	6.54	32.1	8.20	37.4	10.07	37.5	10.14	38.6	10.25	39.7	10.39	39.8	10.52	
45	27.0	6.91	32.1	8.58	37.4	10.24	36.7	10.28	38.4	10.44	39.3	10.55	39.0	10.66	
48	27.0	7.21	32.1	8.88	37.4	10.26	35.2	10.39	38.3	10.63	36.9	10.66	38.2	10.75	

Abbreviations:

CR: Combination ratio

TC: Total capacity (kW)

PI: Power input (compressor + outdoor fan motor) (kW)

Notes:

1. Shaded cells indicate rating condition.

Table continued on next page ...

Table 2-8.4: VMEX012Q8A-D23V400 cooling capacity (continued)

CR	Outdoor air temp. (°C DB)	Indoor air temp. (°C DB / °C WB)													
		20.8 / 14.0		23.3 / 16.0		25.8 / 18.0		27.0 / 19.0		28.2 / 20.0		30.7 / 22.0		32.0 / 24.0	
		TC	PI	TC	PI	TC	PI	TC	PI	TC	PI	TC	PI	TC	PI
		kW	kW	kW	kW	kW	kW	kW	kW	kW	kW	kW	kW	kW	kW
90%	-5	24.3	2.58	29.0	3.10	33.7	3.66	36.0	3.99	38.3	4.24	43.0	4.88	47.7	5.59
	-2	24.3	2.61	29.0	3.13	33.7	3.70	36.0	4.04	38.3	4.29	43.0	4.93	47.7	5.64
	0	24.3	2.65	29.0	3.17	33.7	3.76	36.0	4.09	38.3	4.35	43.0	4.98	47.7	5.69
	2	24.3	2.69	29.0	3.21	33.7	3.80	36.0	4.16	38.3	4.42	43.0	5.09	47.7	5.77
	4	24.3	2.73	29.0	3.26	33.7	3.86	36.0	4.21	38.3	4.47	43.0	5.16	47.7	5.85
	6	24.3	2.76	29.0	3.32	33.7	3.93	36.0	4.29	38.3	4.55	43.0	5.25	47.7	5.95
	8	24.3	2.82	29.0	3.38	33.7	4.01	36.0	4.35	38.3	4.63	43.0	5.34	47.7	6.01
	10	24.3	2.87	29.0	3.46	33.7	4.09	36.0	4.41	38.3	4.74	43.0	5.41	47.7	6.10
	12	24.3	2.92	29.0	3.52	33.7	4.16	36.0	4.49	38.3	4.83	43.0	5.51	47.7	6.22
	14	24.3	2.97	29.0	3.58	33.7	4.24	36.0	4.57	38.3	4.91	43.0	5.61	47.7	6.33
	16	24.3	3.02	29.0	3.65	33.7	4.32	36.0	4.66	38.3	5.01	43.0	5.73	47.6	6.44
	18	24.3	3.07	29.0	3.72	33.7	4.40	36.0	4.75	38.3	5.11	43.0	5.84	47.0	6.64
	20	24.3	3.13	29.0	3.81	33.7	4.49	36.0	4.85	38.3	5.30	43.0	6.28	46.3	6.96
	21	24.3	3.16	29.0	3.83	33.7	4.56	36.0	5.01	38.3	5.49	43.0	6.50	46.0	7.12
	23	24.3	3.22	29.0	3.99	33.7	4.89	36.0	5.38	38.3	5.89	43.0	6.98	45.3	7.44
	25	24.3	3.40	29.0	4.26	33.7	5.23	36.0	5.75	38.3	6.29	43.0	7.47	44.7	7.77
	27	24.3	3.61	29.0	4.54	33.7	5.58	36.0	6.14	38.3	6.73	43.0	8.00	44.0	8.10
	29	24.3	3.85	29.0	4.84	33.7	5.95	36.0	6.55	38.3	7.19	42.6	8.36	43.4	8.42
	31	24.3	4.09	29.0	5.15	33.7	6.34	36.0	6.99	38.3	7.67	41.9	8.69	42.7	8.76
	33	24.3	4.34	29.0	5.48	33.7	6.77	36.0	7.46	38.3	8.18	41.3	9.02	42.1	9.09
35	24.3	4.61	29.0	5.83	33.7	7.21	36.0	7.95	38.3	8.72	40.6	9.35	41.4	9.42	
37	24.3	4.89	29.0	6.19	33.7	7.67	36.0	8.46	38.3	9.30	39.9	9.68	40.9	9.75	
39	24.3	5.19	29.0	6.59	33.7	8.16	36.0	9.01	38.3	9.90	39.3	10.01	40.1	10.09	
41	24.3	5.37	29.0	6.89	33.7	8.46	36.0	9.25	38.3	9.96	39.0	10.27	39.9	10.33	
43	24.3	5.63	29.0	7.19	33.7	8.75	36.0	9.49	38.3	10.17	38.8	10.40	39.5	10.49	
45	24.3	5.98	29.0	7.55	33.7	9.11	36.0	9.81	38.3	10.46	38.6	10.51	38.9	10.63	
48	24.3	6.32	29.0	7.90	33.7	9.46	36.0	9.93	38.3	10.55	38.3	10.66	37.9	10.77	
80%	-5	21.6	2.28	25.7	2.69	29.9	3.19	32.0	3.39	34.1	3.65	38.3	4.22	42.4	4.81
	-2	21.6	2.31	25.7	2.72	29.9	3.21	32.0	3.44	34.1	3.68	38.3	4.26	42.4	4.86
	0	21.6	2.35	25.7	2.76	29.9	3.25	32.0	3.48	34.1	3.75	38.3	4.32	42.4	4.93
	2	21.6	2.40	25.7	2.80	29.9	3.30	32.0	3.55	34.1	3.82	38.3	4.40	42.4	5.02
	4	21.6	2.44	25.7	2.84	29.9	3.36	32.0	3.63	34.1	3.88	38.3	4.48	42.4	5.09
	6	21.6	2.48	25.7	2.91	29.9	3.41	32.0	3.71	34.1	3.96	38.3	4.55	42.4	5.17
	8	21.6	2.52	25.7	2.98	29.9	3.49	32.0	3.77	34.1	4.04	38.3	4.62	42.4	5.27
	10	21.6	2.54	25.7	3.05	29.9	3.58	32.0	3.86	34.1	4.14	38.3	4.73	42.4	5.33
	12	21.6	2.58	25.7	3.10	29.9	3.65	32.0	3.94	34.1	4.22	38.3	4.81	42.4	5.43
	14	21.6	2.63	25.7	3.16	29.9	3.71	32.0	4.00	34.1	4.30	38.3	4.90	42.4	5.53
	16	21.6	2.67	25.7	3.21	29.9	3.79	32.0	4.07	34.1	4.37	38.3	5.00	42.4	5.63
	18	21.6	2.72	25.7	3.27	29.9	3.86	32.0	4.16	34.1	4.46	38.3	5.10	42.4	5.74
	20	21.6	2.77	25.7	3.33	29.9	3.94	32.0	4.24	34.1	4.55	38.3	5.29	42.4	6.14
	21	21.6	2.80	25.7	3.36	29.9	3.97	32.0	4.29	34.1	4.65	38.3	5.48	42.4	6.37
	23	21.6	2.85	25.7	3.43	29.9	4.16	32.0	4.56	34.1	4.98	38.3	5.87	42.4	6.83
	25	21.6	2.93	25.7	3.65	29.9	4.45	32.0	4.88	34.1	5.31	38.3	6.28	42.4	7.31
	27	21.6	3.12	25.7	3.89	29.9	4.74	32.0	5.20	34.1	5.68	38.3	6.71	42.4	7.82
	29	21.6	3.32	25.7	4.14	29.9	5.05	32.0	5.54	34.1	6.07	38.3	7.16	42.4	8.36
	31	21.6	3.52	25.7	4.40	29.9	5.38	32.0	5.90	34.1	6.47	38.3	7.65	41.7	8.69
	33	21.6	3.75	25.7	4.68	29.9	5.73	32.0	6.29	34.1	6.88	38.3	8.15	41.1	9.01
35	21.6	3.97	25.7	4.98	29.9	6.09	32.0	6.69	34.1	7.33	38.3	8.69	40.4	9.34	
37	21.6	4.21	25.7	5.28	29.9	6.48	32.0	7.13	34.1	7.81	38.3	9.26	39.9	9.66	
39	21.6	4.46	25.7	5.63	29.9	6.89	32.0	7.58	34.1	8.31	38.3	9.86	39.1	10.00	
41	21.6	4.56	25.7	5.68	29.9	6.99	32.0	7.78	34.1	8.46	38.3	10.12	38.9	10.18	
43	21.6	4.70	25.7	5.73	29.9	7.09	32.0	7.92	34.1	8.58	38.3	10.23	38.7	10.29	
45	21.6	4.83	25.7	5.79	29.9	7.23	32.0	8.09	34.1	8.73	38.3	10.34	38.2	10.46	
48	21.6	4.99	25.7	5.84	29.9	7.35	32.0	8.20	34.1	8.80	38.3	10.45	37.9	10.60	

Abbreviations:

CR: Combination ratio

TC: Total capacity (kW)

PI: Power input (compressor + outdoor fan motor) (kW)

Notes:

1. Shaded cells indicate rating condition.

Table continued on next page ...

# VMEX 460V 60Hz

Table 2-8.4: VMEX012Q8A-D23V400 cooling capacity (continued)

CR	Outdoor air temp. (°C DB)	Indoor air temp. (°C DB / °C WB)													
		20.8 / 14.0		23.3 / 16.0		25.8 / 18.0		27.0 / 19.0		28.2 / 20.0		30.7 / 22.0		32.0 / 24.0	
		TC	PI	TC	PI	TC	PI	TC	PI	TC	PI	TC	PI	TC	PI
		kW	kW	kW	kW	kW	kW	kW	kW	kW	kW	kW	kW	kW	kW
70%	-5	18.9	2.03	22.6	2.38	26.1	2.70	28.0	2.89	29.9	3.09	33.4	3.53	37.1	4.06
	-2	18.9	2.05	22.6	2.39	26.1	2.72	28.0	2.95	29.9	3.14	33.4	3.59	37.1	4.12
	0	18.9	2.06	22.6	2.43	26.1	2.77	28.0	3.01	29.9	3.20	33.4	3.66	37.1	4.17
	2	18.9	2.07	22.6	2.44	26.1	2.82	28.0	3.06	29.9	3.26	33.4	3.74	37.1	4.24
	4	18.9	2.10	22.6	2.50	26.1	2.88	28.0	3.12	29.9	3.33	33.4	3.80	37.1	4.34
	6	18.9	2.13	22.6	2.54	26.1	2.95	28.0	3.22	29.9	3.41	33.4	3.87	37.1	4.42
	8	18.9	2.17	22.6	2.62	26.1	3.02	28.0	3.27	29.9	3.48	33.4	3.98	37.1	4.51
	10	18.9	2.21	22.6	2.66	26.1	3.10	28.0	3.33	29.9	3.57	33.4	4.06	37.1	4.56
	12	18.9	2.27	22.6	2.69	26.1	3.16	28.0	3.40	29.9	3.64	33.4	4.14	37.1	4.65
	14	18.9	2.31	22.6	2.74	26.1	3.21	28.0	3.45	29.9	3.70	33.4	4.21	37.1	4.74
	16	18.9	2.34	22.6	2.80	26.1	3.27	28.0	3.52	29.9	3.77	33.4	4.29	37.1	4.83
	18	18.9	2.38	22.6	2.85	26.1	3.33	28.0	3.58	29.9	3.84	33.4	4.37	37.1	4.93
	20	18.9	2.42	22.6	2.90	26.1	3.40	28.0	3.65	29.9	3.91	33.4	4.46	37.1	5.06
	21	18.9	2.44	22.6	2.92	26.1	3.42	28.0	3.69	29.9	3.95	33.4	4.52	37.1	5.24
	23	18.9	2.48	22.6	2.97	26.1	3.50	28.0	3.81	29.9	4.15	33.4	4.85	37.1	5.62
	25	18.9	2.53	22.6	3.10	26.1	3.72	28.0	4.07	29.9	4.42	33.4	5.19	37.1	6.00
	27	18.9	2.68	22.6	3.30	26.1	3.97	28.0	4.34	29.9	4.73	33.4	5.54	37.1	6.42
	29	18.9	2.85	22.6	3.50	26.1	4.22	28.0	4.63	29.9	5.03	33.4	5.90	37.1	6.86
	31	18.9	3.01	22.6	3.71	26.1	4.50	28.0	4.91	29.9	5.35	33.4	6.29	37.1	7.31
	33	18.9	3.20	22.6	3.95	26.1	4.79	28.0	5.23	29.9	5.70	33.4	6.71	37.1	7.80
35	18.9	3.38	22.6	4.19	26.1	5.08	28.0	5.57	29.9	6.07	33.4	7.14	37.1	8.31	
37	18.9	3.57	22.6	4.44	26.1	5.40	28.0	5.90	29.9	6.45	33.4	7.61	37.1	8.85	
39	18.9	3.79	22.6	4.70	26.1	5.73	28.0	6.28	29.9	6.86	33.4	8.08	37.1	9.43	
41	18.9	3.95	22.6	4.87	26.1	5.90	28.0	6.49	29.9	7.06	33.4	8.42	37.1	9.84	
43	18.9	4.27	22.6	5.20	26.1	6.14	28.0	6.84	29.9	7.27	33.4	8.72	37.1	10.15	
45	18.9	4.37	22.6	5.31	26.1	6.27	28.0	6.95	29.9	7.64	33.4	9.20	37.1	10.54	
48	18.9	4.48	22.6	5.36	26.1	6.33	28.0	7.06	29.9	7.84	33.4	9.61	37.1	10.79	
60%	-5	16.1	1.73	19.3	2.01	22.4	2.34	24.0	2.50	25.6	2.69	28.7	3.03	31.9	3.47
	-2	16.1	1.74	19.3	2.04	22.4	2.38	24.0	2.53	25.6	2.72	28.7	3.07	31.9	3.49
	0	16.1	1.77	19.3	2.07	22.4	2.42	24.0	2.56	25.6	2.77	28.7	3.12	31.9	3.54
	2	16.1	1.80	19.3	2.11	22.4	2.46	24.0	2.61	25.6	2.80	28.7	3.18	31.9	3.58
	4	16.1	1.85	19.3	2.15	22.4	2.51	24.0	2.64	25.6	2.85	28.7	3.23	31.9	3.63
	6	16.1	1.87	19.3	2.20	22.4	2.56	24.0	2.70	25.6	2.90	28.7	3.29	31.9	3.72
	8	16.1	1.91	19.3	2.23	22.4	2.60	24.0	2.75	25.6	2.96	28.7	3.36	31.9	3.78
	10	16.1	1.94	19.3	2.28	22.4	2.64	24.0	2.83	25.6	3.02	28.7	3.42	31.9	3.83
	12	16.1	1.98	19.3	2.32	22.4	2.69	24.0	2.88	25.6	3.07	28.7	3.48	31.9	3.90
	14	16.1	2.01	19.3	2.36	22.4	2.73	24.0	2.93	25.6	3.13	28.7	3.55	31.9	3.97
	16	16.1	2.03	19.3	2.39	22.4	2.78	24.0	2.98	25.6	3.18	28.7	3.61	31.9	4.05
	18	16.1	2.07	19.3	2.43	22.4	2.83	24.0	3.03	25.6	3.25	28.7	3.67	31.9	4.12
	20	16.1	2.09	19.3	2.48	22.4	2.88	24.0	3.10	25.6	3.31	28.7	3.75	31.9	4.21
	21	16.1	2.12	19.3	2.49	22.4	2.91	24.0	3.12	25.6	3.33	28.7	3.78	31.9	4.25
	23	16.1	2.14	19.3	2.54	22.4	2.96	24.0	3.18	25.6	3.40	28.7	3.93	31.9	4.52
	25	16.1	2.18	19.3	2.58	22.4	3.07	24.0	3.33	25.6	3.61	28.7	4.20	31.9	4.82
	27	16.1	2.27	19.3	2.74	22.4	3.27	24.0	3.56	25.6	3.85	28.7	4.47	31.9	5.15
	29	16.1	2.39	19.3	2.91	22.4	3.48	24.0	3.78	25.6	4.10	28.7	4.77	31.9	5.50
	31	16.1	2.54	19.3	3.08	22.4	3.70	24.0	4.02	25.6	4.36	28.7	5.08	31.9	5.85
	33	16.1	2.68	19.3	3.27	22.4	3.92	24.0	4.27	25.6	4.64	28.7	5.40	31.9	6.24
35	16.1	2.84	19.3	3.47	22.4	4.16	24.0	4.54	25.6	4.92	28.7	5.75	31.9	6.64	
37	16.1	3.01	19.3	3.67	22.4	4.41	24.0	4.81	25.6	5.23	28.7	6.12	31.9	7.07	
39	16.1	3.17	19.3	3.89	22.4	4.67	24.0	5.10	25.6	5.55	28.7	6.49	31.9	7.52	
41	16.1	3.27	19.3	4.05	22.4	4.84	24.0	5.30	25.6	5.76	28.7	6.80	31.9	7.86	
43	16.1	3.37	19.3	4.22	22.4	5.01	24.0	5.46	25.6	5.96	28.7	7.09	31.9	8.20	
45	16.1	3.53	19.3	4.44	22.4	5.22	24.0	5.67	25.6	6.25	28.7	7.40	31.9	8.65	
48	16.1	3.67	19.3	4.63	22.4	5.40	24.0	5.81	25.6	6.49	28.7	7.67	31.9	9.06	

Abbreviations:

CR: Combination ratio

TC: Total capacity (kW)

PI: Power input (compressor + outdoor fan motor) (kW)

Notes:

1. Shaded cells indicate rating condition.

Table continued on next page ...

Table 2-8.4: VMEX012Q8A-D23V400 cooling capacity (continued)

CR	Outdoor air temp. (°C DB)	Indoor air temp. (°C DB / °C WB)													
		20.8 / 14.0		23.3 / 16.0		25.8 / 18.0		27.0 / 19.0		28.2 / 20.0		30.7 / 22.0		32.0 / 24.0	
		TC	PI	TC	PI	TC	PI	TC	PI	TC	PI	TC	PI	TC	PI
		kW	kW	kW	kW	kW	kW	kW	kW	kW	kW	kW	kW	kW	kW
50%	-5	13.5	1.51	16.1	1.74	18.7	2.00	20.0	2.09	21.3	2.21	23.9	2.51	26.6	2.71
	-2	13.5	1.52	16.1	1.78	18.7	2.02	20.0	2.12	21.3	2.25	23.9	2.54	26.6	2.74
	0	13.5	1.54	16.1	1.80	18.7	2.06	20.0	2.15	21.3	2.27	23.9	2.59	26.6	2.79
	2	13.5	1.56	16.1	1.83	18.7	2.09	20.0	2.18	21.3	2.31	23.9	2.60	26.6	2.84
	4	13.5	1.58	16.1	1.86	18.7	2.12	20.0	2.21	21.3	2.36	23.9	2.66	26.6	2.92
	6	13.5	1.61	16.1	1.89	18.7	2.15	20.0	2.26	21.3	2.40	23.9	2.70	26.6	3.00
	8	13.5	1.65	16.1	1.92	18.7	2.18	20.0	2.31	21.3	2.44	23.9	2.75	26.6	3.10
	10	13.5	1.68	16.1	1.94	18.7	2.22	20.0	2.35	21.3	2.51	23.9	2.82	26.6	3.15
	12	13.5	1.69	16.1	1.97	18.7	2.26	20.0	2.39	21.3	2.56	23.9	2.87	26.6	3.20
	14	13.5	1.72	16.1	1.99	18.7	2.28	20.0	2.44	21.3	2.59	23.9	2.92	26.6	3.26
	16	13.5	1.74	16.1	2.02	18.7	2.32	20.0	2.48	21.3	2.63	23.9	2.97	26.6	3.31
	18	13.5	1.77	16.1	2.06	18.7	2.36	20.0	2.52	21.3	2.68	23.9	3.02	26.6	3.37
	20	13.5	1.79	16.1	2.08	18.7	2.39	20.0	2.56	21.3	2.73	23.9	3.07	26.6	3.43
	21	13.5	1.80	16.1	2.11	18.7	2.42	20.0	2.58	21.3	2.76	23.9	3.11	26.6	3.47
	23	13.5	1.83	16.1	2.13	18.7	2.46	20.0	2.63	21.3	2.81	23.9	3.16	26.6	3.55
	25	13.5	1.85	16.1	2.17	18.7	2.51	20.0	2.68	21.3	2.90	23.9	3.32	26.6	3.78
	27	13.5	1.89	16.1	2.26	18.7	2.64	20.0	2.86	21.3	3.07	23.9	3.53	26.6	4.04
	29	13.5	1.99	16.1	2.38	18.7	2.81	20.0	3.03	21.3	3.27	23.9	3.76	26.6	4.30
	31	13.5	2.11	16.1	2.52	18.7	2.97	20.0	3.22	21.3	3.47	23.9	4.00	26.6	4.57
	33	13.5	2.23	16.1	2.67	18.7	3.16	20.0	3.41	21.3	3.68	23.9	4.25	26.6	4.86
35	13.5	2.36	16.1	2.82	18.7	3.33	20.0	3.61	21.3	3.90	23.9	4.51	26.6	5.16	
37	13.5	2.48	16.1	2.98	18.7	3.53	20.0	3.82	21.3	4.14	23.9	4.79	26.6	5.49	
39	13.5	2.62	16.1	3.15	18.7	3.73	20.0	4.05	21.3	4.39	23.9	5.08	26.6	5.83	
41	13.5	2.73	16.1	3.28	18.7	3.87	20.0	4.24	21.3	4.58	23.9	5.35	26.6	6.10	
43	13.5	2.91	16.1	3.51	18.7	4.01	20.0	4.43	21.3	4.69	23.9	5.62	26.6	6.37	
45	13.5	2.97	16.1	3.60	18.7	4.28	20.0	4.77	21.3	4.89	23.9	6.16	26.6	6.91	
48	13.5	3.04	16.1	3.70	18.7	4.53	20.0	5.07	21.3	5.11	23.9	6.65	26.6	7.44	

Abbreviations:

CR: Combination ratio

TC: Total capacity (kW)

PI: Power input (compressor + outdoor fan motor) (kW)

Notes:

1. Shaded cells indicate rating condition.

# VMEX 460V 60Hz

Table 2-8.5: VMEX014Q8A-D26V450 cooling capacity

CR	Outdoor air temp. (°C DB)	Indoor air temp. (°C DB / °C WB)													
		20.8 / 14.0		23.3 / 16.0		25.8 / 18.0		27.0 / 19.0		28.2 / 20.0		30.7 / 22.0		32.0 / 24.0	
		TC	PI	TC	PI	TC	PI	TC	PI	TC	PI	TC	PI	TC	PI
		kW	kW	kW	kW	kW	kW	kW	kW	kW	kW	kW	kW	kW	kW
130%	-5	39.5	4.49	47.1	5.48	54.6	5.87	56.7	6.11	59.5	6.28	60.9	6.83	62.4	6.88
	-2	39.5	4.49	47.1	5.58	54.6	5.87	56.7	6.15	59.5	6.28	60.9	6.92	62.4	6.95
	0	39.5	4.57	47.1	5.68	54.6	6.09	56.7	6.48	59.5	6.65	60.9	7.01	62.4	7.04
	2	39.5	4.65	47.1	5.69	54.6	6.30	56.7	6.85	59.5	6.73	60.9	7.06	62.4	7.14
	4	39.5	4.75	47.1	5.80	54.6	6.51	56.7	6.88	59.5	6.81	60.9	7.16	62.4	7.28
	6	39.5	4.84	47.1	5.92	54.6	6.75	56.7	6.94	58.8	7.03	60.2	7.28	61.8	7.33
	8	39.5	4.96	47.1	6.06	54.6	7.09	56.7	7.28	58.1	7.25	59.5	7.30	61.0	7.40
	10	39.5	5.06	47.1	6.19	54.6	7.35	56.7	7.52	57.4	7.39	58.8	7.41	60.3	7.62
	12	39.5	5.15	47.1	6.30	54.6	7.50	55.9	7.63	56.7	7.50	58.0	7.52	59.5	7.67
	14	39.5	5.25	47.1	6.42	54.5	7.61	55.3	7.74	55.9	7.61	57.4	7.63	58.8	7.84
	16	39.5	5.34	47.1	6.56	53.8	7.73	54.5	7.84	55.1	7.84	56.6	7.75	58.0	7.96
	18	39.5	5.45	47.1	6.69	53.0	7.84	53.7	7.89	54.5	7.93	55.9	8.01	57.4	8.08
	20	39.5	5.56	47.1	7.12	52.2	8.23	53.0	8.27	53.7	8.32	55.1	8.39	56.6	8.48
	21	39.5	5.71	47.1	7.37	51.9	8.42	52.7	8.46	53.4	8.51	54.8	8.60	56.2	8.67
	23	39.5	6.13	47.1	7.90	51.3	8.81	51.9	8.85	52.6	8.89	54.0	8.98	55.4	9.07
	25	39.5	6.54	47.1	8.46	50.5	9.19	51.1	9.23	51.9	9.29	53.4	9.38	54.8	9.47
	27	39.5	6.99	47.1	9.06	49.8	9.58	50.5	9.63	51.1	9.68	52.6	9.78	54.0	9.89
	29	39.5	7.46	47.1	9.68	49.0	9.96	49.7	10.02	50.5	10.08	51.9	10.18	53.4	10.29
	31	39.5	7.96	46.9	10.24	48.2	10.36	49.0	10.42	49.7	10.46	51.1	10.58	52.6	10.70
	33	39.5	8.48	46.1	10.63	47.6	10.74	48.2	10.80	49.0	10.86	50.5	10.98	51.7	11.10
35	39.5	9.04	45.3	11.01	46.8	11.14	47.6	11.20	48.2	11.26	49.7	11.40	51.1	11.51	
37	39.5	9.62	44.7	11.41	46.1	11.54	46.8	11.60	47.6	11.68	48.9	11.81	50.3	11.94	
39	39.5	10.24	43.9	11.53	45.3	11.93	46.1	12.00	46.8	12.08	48.2	12.21	49.7	12.36	
41	39.5	10.78	43.4	11.64	44.8	12.04	45.6	12.11	46.3	12.19	47.7	12.23	47.8	12.47	
43	39.5	11.05	43.1	11.70	44.6	12.07	45.4	12.17	45.8	12.20	46.9	12.26	47.2	12.50	
45	39.5	11.60	42.8	11.81	44.1	12.19	44.9	12.25	45.1	12.26	45.6	12.30	46.3	12.73	
48	39.5	12.01	42.7	12.19	43.4	12.30	44.2	12.36	44.6	12.40	44.4	12.51	45.2	12.77	
120%	-5	36.5	4.34	43.4	5.25	50.5	6.21	54.0	6.77	56.6	7.06	57.9	7.28	59.1	7.48
	-2	36.5	4.38	43.4	5.31	50.5	6.27	54.0	6.81	56.6	7.14	57.9	7.34	59.1	7.50
	0	36.5	4.42	43.4	5.34	50.5	6.34	54.0	6.83	56.6	7.21	57.9	7.39	59.1	7.52
	2	36.5	4.43	43.4	5.40	50.5	6.39	54.0	6.89	56.6	7.23	57.9	7.44	59.1	7.53
	4	36.5	4.47	43.4	5.47	50.5	6.48	54.0	6.96	56.6	7.33	57.9	7.46	59.1	7.55
	6	36.5	4.52	43.4	5.51	50.5	6.55	54.0	7.03	56.6	7.41	57.9	7.52	59.1	7.58
	8	36.5	4.56	43.4	5.56	50.5	6.64	54.0	7.12	56.6	7.48	57.9	7.54	59.1	7.62
	10	36.5	4.62	43.4	5.64	50.5	6.70	54.0	7.25	56.6	7.49	57.9	7.57	59.1	7.65
	12	36.5	4.71	43.4	5.74	50.5	6.84	54.0	7.38	55.8	7.52	57.1	7.52	58.3	7.70
	14	36.5	4.80	43.4	5.86	50.5	6.97	54.0	7.53	55.0	7.57	56.4	7.64	57.7	7.79
	16	36.5	4.88	43.4	5.98	50.5	7.10	53.7	7.67	54.3	7.68	55.6	7.77	56.9	7.91
	18	36.5	4.97	43.4	6.10	50.5	7.34	52.9	7.84	53.5	7.87	54.8	7.95	56.2	8.02
	20	36.5	5.08	43.4	6.33	50.5	7.90	52.2	8.23	52.9	8.26	54.2	8.33	55.4	8.41
	21	36.5	5.12	43.4	6.56	50.5	8.18	51.7	8.42	52.4	8.45	53.8	8.52	55.1	8.61
	23	36.5	5.48	43.4	7.03	50.5	8.76	51.1	8.79	51.7	8.83	53.0	8.92	54.3	9.00
	25	36.5	5.85	43.4	7.52	49.7	9.15	50.3	9.18	50.9	9.22	52.4	9.31	53.7	9.40
	27	36.5	6.25	43.4	8.04	49.0	9.52	49.7	9.57	50.3	9.62	51.6	9.71	52.9	9.80
	29	36.5	6.66	43.4	8.58	48.2	9.90	48.9	9.96	49.5	10.00	50.8	10.11	52.2	10.20
	31	36.5	7.10	43.4	9.16	47.4	10.30	48.2	10.34	48.9	10.40	50.1	10.51	51.4	10.61
	33	36.5	7.56	43.4	9.77	46.8	10.68	47.4	10.74	48.1	10.79	49.3	10.91	50.6	11.01
35	36.5	8.05	43.4	10.42	46.0	11.07	46.6	11.13	47.4	11.19	48.7	11.31	50.0	11.42	
37	36.5	8.57	43.4	11.10	45.3	11.47	46.0	11.53	46.6	11.59	47.9	11.71	49.2	11.84	
39	36.5	9.12	43.2	11.72	44.5	11.85	45.2	11.93	45.8	11.99	47.2	12.12	48.5	12.24	
41	36.5	9.37	42.9	11.80	44.2	11.94	44.8	12.01	45.5	12.07	46.9	12.15	47.1	12.33	
43	36.5	9.50	42.7	11.89	43.8	12.01	44.5	12.06	45.1	12.11	46.1	12.19	46.4	12.58	
45	36.5	9.62	42.4	12.00	43.4	12.12	44.0	12.17	44.7	12.21	45.2	12.22	45.9	12.85	
48	36.5	9.69	42.1	12.13	42.8	12.23	43.3	12.26	44.2	12.31	44.5	12.27	45.3	13.01	

Abbreviations:

CR: Combination ratio

TC: Total capacity (kW)

PI: Power input (compressor + outdoor fan motor) (kW)

Notes:

1. Shaded cells indicate rating condition.

Table continued on next page ...



Table 2-8.5: VMEX014Q8A-D26V450 cooling capacity (continued)

CR	Outdoor air temp. (°C DB)	Indoor air temp. (°C DB / °C WB)													
		20.8 / 14.0		23.3 / 16.0		25.8 / 18.0		27.0 / 19.0		28.2 / 20.0		30.7 / 22.0		32.0 / 24.0	
		TC	PI	TC	PI	TC	PI	TC	PI	TC	PI	TC	PI	TC	PI
		kW	kW	kW	kW	kW	kW	kW	kW	kW	kW	kW	kW	kW	kW
110%	-5	33.4	3.79	39.9	4.71	46.3	5.62	49.5	6.04	52.7	6.49	56.7	6.75	58.0	6.95
	-2	33.4	3.86	39.9	4.77	46.3	5.67	49.5	6.10	52.7	6.55	56.7	6.81	58.0	6.99
	0	33.4	3.90	39.9	4.80	46.3	5.71	49.5	6.14	52.7	6.62	56.7	6.88	58.0	7.07
	2	33.4	3.98	39.9	4.85	46.3	5.80	49.5	6.20	52.7	6.69	56.7	6.98	58.0	7.16
	4	33.4	4.06	39.9	4.90	46.3	5.86	49.5	6.28	52.7	6.79	56.7	7.07	58.0	7.23
	6	33.4	4.10	39.9	4.96	46.3	5.92	49.5	6.38	52.7	6.87	56.7	7.15	58.0	7.34
	8	33.4	4.14	39.9	5.04	46.3	5.98	49.5	6.44	52.7	6.95	56.7	7.20	58.0	7.42
	10	33.4	4.19	39.9	5.11	46.3	6.07	49.5	6.56	52.7	7.06	56.7	7.25	58.0	7.48
	12	33.4	4.28	39.9	5.21	46.3	6.19	49.5	6.69	52.7	7.19	56.1	7.35	57.2	7.58
	14	33.4	4.35	39.9	5.30	46.3	6.30	49.5	6.81	52.7	7.33	55.3	7.41	56.6	7.63
	16	33.4	4.43	39.9	5.40	46.3	6.42	49.5	6.94	52.7	7.47	54.6	7.50	55.8	7.72
	18	33.4	4.51	39.9	5.51	46.3	6.56	49.5	7.13	52.7	7.83	53.8	7.89	55.1	7.96
	20	33.4	4.60	39.9	5.62	46.3	6.94	49.5	7.67	51.9	8.21	53.2	8.27	54.3	8.35
	21	33.4	4.65	39.9	5.79	46.3	7.19	49.5	7.95	51.6	8.41	52.7	8.46	54.0	8.54
	23	33.4	4.87	39.9	6.20	46.3	7.71	49.5	8.52	50.8	8.78	52.1	8.86	53.2	8.94
	25	33.4	5.19	39.9	6.63	46.3	8.24	49.5	9.13	50.1	9.16	51.3	9.25	52.6	9.32
	27	33.4	5.54	39.9	7.09	46.3	8.82	48.7	9.52	49.3	9.55	50.6	9.63	51.8	9.72
	29	33.4	5.90	39.9	7.56	46.3	9.43	48.1	9.90	48.7	9.94	49.8	10.03	51.1	10.12
	31	33.4	6.29	39.9	8.07	46.3	10.06	47.3	10.29	47.9	10.33	49.2	10.42	50.3	10.52
	33	33.4	6.69	39.9	8.60	46.0	10.61	46.6	10.67	47.3	10.71	48.4	10.82	49.7	10.92
	35	33.4	7.12	39.9	9.16	45.2	10.99	45.8	11.05	46.4	11.11	47.6	11.22	48.9	11.32
37	33.4	7.58	39.9	9.75	44.5	11.40	45.2	11.44	45.6	11.50	46.9	11.62	48.1	11.72	
39	33.4	8.05	39.9	10.39	43.7	11.78	44.4	11.84	45.0	11.90	46.1	12.02	47.4	12.13	
41	33.4	8.13	39.9	10.47	43.4	11.86	44.0	11.92	44.7	11.98	45.5	12.10	46.0	12.22	
43	33.4	8.22	39.9	10.61	43.0	11.95	43.7	12.01	44.3	12.06	45.1	12.14	45.3	12.47	
45	33.4	8.48	39.9	10.67	42.6	12.06	43.2	12.15	43.9	12.17	44.7	12.48	44.9	12.76	
48	33.4	8.78	39.9	11.57	42.0	12.14	42.5	12.24	43.4	12.30	43.9	12.52	44.3	12.89	
100%	-5	30.4	3.45	36.2	4.15	42.1	4.94	45.0	5.29	47.9	5.74	53.8	6.54	56.9	6.83
	-2	30.4	3.49	36.2	4.21	42.1	5.00	45.0	5.39	47.9	5.82	53.8	6.62	56.9	6.87
	0	30.4	3.52	36.2	4.25	42.1	5.05	45.0	5.46	47.9	5.87	53.8	6.73	56.9	6.95
	2	30.4	3.59	36.2	4.31	42.1	5.11	45.0	5.53	47.9	5.94	53.8	6.83	56.9	7.06
	4	30.4	3.62	36.2	4.35	42.1	5.18	45.0	5.61	47.9	6.02	53.8	6.90	56.9	7.14
	6	30.4	3.67	36.2	4.44	42.1	5.25	45.0	5.71	47.9	6.10	53.8	6.99	56.9	7.25
	8	30.4	3.74	36.2	4.50	42.1	5.35	45.0	5.78	47.9	6.20	53.8	7.10	56.9	7.37
	10	30.4	3.79	36.2	4.59	42.1	5.43	45.0	5.87	47.9	6.32	53.8	7.22	56.9	7.47
	12	30.4	3.85	36.2	4.68	42.1	5.53	45.0	5.98	47.9	6.44	53.8	7.35	56.1	7.53
	14	30.4	3.92	36.2	4.77	42.1	5.64	45.0	6.10	47.9	6.56	53.8	7.50	55.4	7.62
	16	30.4	4.00	36.2	4.85	42.1	5.76	45.0	6.21	47.9	6.69	53.5	7.59	54.6	7.71
	18	30.4	4.07	36.2	4.94	42.1	5.86	45.0	6.33	47.9	6.82	52.9	7.84	54.0	7.90
	20	30.4	4.14	36.2	5.05	42.1	6.04	45.0	6.66	47.9	7.31	52.1	8.21	53.2	8.29
	21	30.4	4.19	36.2	5.09	42.1	6.26	45.0	6.90	47.9	7.56	51.8	8.41	52.9	8.48
	23	30.4	4.29	36.2	5.43	42.1	6.70	45.0	7.38	47.9	8.11	51.1	8.79	52.1	8.86
	25	30.4	4.57	36.2	5.80	42.1	7.18	45.0	7.92	47.9	8.69	50.3	9.17	51.4	9.25
	27	30.4	4.88	36.2	6.19	42.1	7.67	45.0	8.46	47.9	9.29	49.5	9.56	50.6	9.65
	29	30.4	5.19	36.2	6.60	42.1	8.18	45.0	9.04	47.7	9.87	48.9	9.96	50.0	10.03
	31	30.4	5.53	36.2	7.04	42.1	8.73	45.0	9.65	47.1	10.26	48.1	10.34	49.2	10.43
	33	30.4	5.87	36.2	7.50	42.1	9.31	45.0	10.30	46.3	10.64	47.4	10.73	48.5	10.83
	35	30.4	6.24	36.2	7.98	42.1	9.93	45.0	10.98	45.5	11.02	46.6	11.13	47.7	11.22
37	30.4	6.64	36.2	8.49	42.1	10.58	44.2	11.36	44.8	11.42	46.0	11.53	46.9	11.62	
39	30.4	7.06	36.2	9.03	42.1	11.26	43.6	11.75	44.0	11.81	45.2	11.91	46.3	12.03	
41	30.4	7.39	36.2	9.36	42.1	11.67	42.9	11.83	43.7	11.99	44.4	12.19	45.6	12.28	
43	30.4	7.72	36.2	9.69	42.1	11.89	42.2	11.97	43.4	12.11	44.6	12.27	44.8	12.42	
45	30.4	8.16	36.2	10.12	42.1	12.09	41.3	12.13	43.2	12.33	44.3	12.46	43.9	12.58	
48	30.4	8.51	36.2	10.48	42.1	12.11	39.6	12.27	43.1	12.54	41.6	12.59	42.9	12.70	

Abbreviations:

CR: Combination ratio

TC: Total capacity (kW)

PI: Power input (compressor + outdoor fan motor) (kW)

Notes:

1. Shaded cells indicate rating condition.

Table continued on next page ...

# VMEX 460V 60Hz

Table 2-8.5: VMEX014Q8A-D26V450 cooling capacity (continued)

CR	Outdoor air temp. (°C DB)	Indoor air temp. (°C DB / °C WB)													
		20.8 / 14.0		23.3 / 16.0		25.8 / 18.0		27.0 / 19.0		28.2 / 20.0		30.7 / 22.0		32.0 / 24.0	
		TC	PI	TC	PI	TC	PI	TC	PI	TC	PI	TC	PI	TC	PI
		kW	kW	kW	kW	kW	kW	kW	kW	kW	kW	kW	kW	kW	kW
90%	-5	27.3	3.05	32.6	3.66	37.9	4.32	40.5	4.71	43.1	5.01	48.4	5.76	53.7	6.60
	-2	27.3	3.08	32.6	3.70	37.9	4.37	40.5	4.78	43.1	5.07	48.4	5.82	53.7	6.66
	0	27.3	3.12	32.6	3.74	37.9	4.44	40.5	4.83	43.1	5.14	48.4	5.88	53.7	6.71
	2	27.3	3.17	32.6	3.79	37.9	4.48	40.5	4.91	43.1	5.22	48.4	6.00	53.7	6.81
	4	27.3	3.22	32.6	3.85	37.9	4.56	40.5	4.97	43.1	5.28	48.4	6.10	53.7	6.91
	6	27.3	3.26	32.6	3.92	37.9	4.64	40.5	5.07	43.1	5.37	48.4	6.19	53.7	7.03
	8	27.3	3.33	32.6	4.00	37.9	4.74	40.5	5.13	43.1	5.47	48.4	6.31	53.7	7.09
	10	27.3	3.39	32.6	4.08	37.9	4.82	40.5	5.21	43.1	5.59	48.4	6.39	53.7	7.21
	12	27.3	3.45	32.6	4.16	37.9	4.91	40.5	5.30	43.1	5.70	48.4	6.51	53.7	7.34
	14	27.3	3.51	32.6	4.23	37.9	5.00	40.5	5.40	43.1	5.80	48.4	6.63	53.7	7.47
	16	27.3	3.57	32.6	4.31	37.9	5.11	40.5	5.50	43.1	5.92	48.4	6.76	53.5	7.61
	18	27.3	3.62	32.6	4.40	37.9	5.19	40.5	5.61	43.1	6.04	48.4	6.90	52.9	7.84
	20	27.3	3.70	32.6	4.50	37.9	5.30	40.5	5.73	43.1	6.26	48.4	7.41	52.1	8.21
	21	27.3	3.73	32.6	4.53	37.9	5.39	40.5	5.92	43.1	6.48	48.4	7.68	51.8	8.40
	23	27.3	3.80	32.6	4.71	37.9	5.77	40.5	6.35	43.1	6.95	48.4	8.24	50.9	8.79
	25	27.3	4.01	32.6	5.03	37.9	6.17	40.5	6.79	43.1	7.43	48.4	8.82	50.3	9.17
	27	27.3	4.26	32.6	5.36	37.9	6.58	40.5	7.25	43.1	7.95	48.4	9.44	49.5	9.56
	29	27.3	4.54	32.6	5.71	37.9	7.03	40.5	7.74	43.1	8.49	47.9	9.87	48.9	9.94
	31	27.3	4.82	32.6	6.08	37.9	7.49	40.5	8.26	43.1	9.06	47.1	10.25	48.1	10.34
	33	27.3	5.12	32.6	6.47	37.9	7.99	40.5	8.80	43.1	9.66	46.4	10.65	47.4	10.73
35	27.3	5.44	32.6	6.88	37.9	8.51	40.5	9.38	43.1	10.30	45.6	11.04	46.6	11.13	
37	27.3	5.77	32.6	7.31	37.9	9.06	40.5	9.99	43.1	10.98	44.8	11.42	46.0	11.51	
39	27.3	6.13	32.6	7.78	37.9	9.63	40.5	10.64	43.1	11.69	44.2	11.82	45.2	11.91	
41	27.3	6.34	32.6	8.14	37.9	9.98	40.5	10.92	43.1	11.76	43.9	12.12	44.9	12.19	
43	27.3	6.64	32.6	8.49	37.9	10.34	40.5	11.20	43.1	12.01	43.7	12.28	44.5	12.38	
45	27.3	7.06	32.6	8.91	37.9	10.76	40.5	11.58	43.1	12.34	43.4	12.41	43.8	12.55	
48	27.3	7.46	32.6	9.32	37.9	11.16	40.5	11.73	43.1	12.45	43.1	12.58	42.6	12.72	
80%	-5	24.3	2.69	28.9	3.18	33.6	3.76	36.0	4.00	38.4	4.31	43.1	4.98	47.7	5.68
	-2	24.3	2.73	28.9	3.22	33.6	3.79	36.0	4.06	38.4	4.35	43.1	5.03	47.7	5.74
	0	24.3	2.77	28.9	3.26	33.6	3.84	36.0	4.11	38.4	4.43	43.1	5.10	47.7	5.82
	2	24.3	2.83	28.9	3.30	33.6	3.90	36.0	4.19	38.4	4.50	43.1	5.20	47.7	5.93
	4	24.3	2.88	28.9	3.36	33.6	3.97	36.0	4.28	38.4	4.58	43.1	5.29	47.7	6.01
	6	24.3	2.92	28.9	3.44	33.6	4.03	36.0	4.38	38.4	4.67	43.1	5.37	47.7	6.11
	8	24.3	2.98	28.9	3.52	33.6	4.13	36.0	4.45	38.4	4.77	43.1	5.45	47.7	6.23
	10	24.3	3.00	28.9	3.60	33.6	4.23	36.0	4.56	38.4	4.88	43.1	5.58	47.7	6.29
	12	24.3	3.05	28.9	3.65	33.6	4.31	36.0	4.65	38.4	4.99	43.1	5.68	47.7	6.41
	14	24.3	3.11	28.9	3.73	33.6	4.38	36.0	4.72	38.4	5.08	43.1	5.79	47.7	6.53
	16	24.3	3.15	28.9	3.79	33.6	4.47	36.0	4.81	38.4	5.16	43.1	5.90	47.7	6.64
	18	24.3	3.21	28.9	3.86	33.6	4.56	36.0	4.91	38.4	5.27	43.1	6.02	47.7	6.78
	20	24.3	3.27	28.9	3.94	33.6	4.65	36.0	5.00	38.4	5.37	43.1	6.25	47.7	7.25
	21	24.3	3.30	28.9	3.97	33.6	4.69	36.0	5.06	38.4	5.49	43.1	6.47	47.7	7.52
	23	24.3	3.36	28.9	4.05	33.6	4.91	36.0	5.39	38.4	5.87	43.1	6.93	47.7	8.07
	25	24.3	3.46	28.9	4.31	33.6	5.25	36.0	5.76	38.4	6.27	43.1	7.41	47.7	8.63
	27	24.3	3.68	28.9	4.59	33.6	5.59	36.0	6.14	38.4	6.70	43.1	7.92	47.7	9.23
	29	24.3	3.92	28.9	4.88	33.6	5.96	36.0	6.54	38.4	7.16	43.1	8.45	47.7	9.87
	31	24.3	4.16	28.9	5.19	33.6	6.35	36.0	6.97	38.4	7.64	43.1	9.03	46.9	10.26
	33	24.3	4.42	28.9	5.52	33.6	6.76	36.0	7.43	38.4	8.12	43.1	9.62	46.3	10.64
35	24.3	4.69	28.9	5.87	33.6	7.19	36.0	7.90	38.4	8.66	43.1	10.26	45.5	11.02	
37	24.3	4.97	28.9	6.23	33.6	7.65	36.0	8.42	38.4	9.22	43.1	10.94	44.8	11.41	
39	24.3	5.27	28.9	6.64	33.6	8.14	36.0	8.95	38.4	9.81	43.1	11.65	44.0	11.81	
41	24.3	5.39	28.9	6.70	33.6	8.26	36.0	9.19	38.4	9.99	43.1	11.94	43.8	12.02	
43	24.3	5.55	28.9	6.76	33.6	8.38	36.0	9.35	38.4	10.13	43.1	12.08	43.5	12.15	
45	24.3	5.70	28.9	6.84	33.6	8.54	36.0	9.55	38.4	10.30	43.1	12.21	43.0	12.34	
48	24.3	5.89	28.9	6.89	33.6	8.67	36.0	9.68	38.4	10.39	43.1	12.34	42.6	12.51	

Abbreviations:

CR: Combination ratio

TC: Total capacity (kW)

PI: Power input (compressor + outdoor fan motor) (kW)

Notes:

1. Shaded cells indicate rating condition.

Table continued on next page ...

Table 2-8.5: VMEX014Q8A-D26V450 cooling capacity (continued)

CR	Outdoor air temp. (°C DB)	Indoor air temp. (°C DB / °C WB)													
		20.8 / 14.0		23.3 / 16.0		25.8 / 18.0		27.0 / 19.0		28.2 / 20.0		30.7 / 22.0		32.0 / 24.0	
		TC	PI	TC	PI	TC	PI	TC	PI	TC	PI	TC	PI	TC	PI
		kW	kW	kW	kW	kW	kW	kW	kW	kW	kW	kW	kW	kW	kW
70%	-5	21.2	2.40	25.4	2.81	29.4	3.19	31.5	3.42	33.6	3.65	37.6	4.17	41.8	4.80
	-2	21.2	2.42	25.4	2.83	29.4	3.21	31.5	3.48	33.6	3.71	37.6	4.24	41.8	4.86
	0	21.2	2.43	25.4	2.86	29.4	3.27	31.5	3.55	33.6	3.78	37.6	4.32	41.8	4.93
	2	21.2	2.44	25.4	2.88	29.4	3.33	31.5	3.61	33.6	3.84	37.6	4.42	41.8	5.01
	4	21.2	2.48	25.4	2.95	29.4	3.40	31.5	3.68	33.6	3.93	37.6	4.49	41.8	5.12
	6	21.2	2.52	25.4	3.00	29.4	3.48	31.5	3.80	33.6	4.02	37.6	4.57	41.8	5.22
	8	21.2	2.56	25.4	3.09	29.4	3.56	31.5	3.86	33.6	4.11	37.6	4.70	41.8	5.32
	10	21.2	2.62	25.4	3.14	29.4	3.66	31.5	3.94	33.6	4.22	37.6	4.79	41.8	5.39
	12	21.2	2.68	25.4	3.18	29.4	3.73	31.5	4.01	33.6	4.29	37.6	4.88	41.8	5.49
	14	21.2	2.72	25.4	3.24	29.4	3.79	31.5	4.07	33.6	4.37	37.6	4.97	41.8	5.59
	16	21.2	2.77	25.4	3.30	29.4	3.86	31.5	4.16	33.6	4.45	37.6	5.06	41.8	5.70
	18	21.2	2.81	25.4	3.36	29.4	3.94	31.5	4.23	33.6	4.53	37.6	5.16	41.8	5.82
	20	21.2	2.86	25.4	3.42	29.4	4.01	31.5	4.31	33.6	4.62	37.6	5.27	41.8	5.98
	21	21.2	2.89	25.4	3.45	29.4	4.04	31.5	4.35	33.6	4.66	37.6	5.34	41.8	6.19
	23	21.2	2.93	25.4	3.51	29.4	4.13	31.5	4.50	33.6	4.90	37.6	5.73	41.8	6.63
	25	21.2	2.99	25.4	3.66	29.4	4.39	31.5	4.81	33.6	5.22	37.6	6.13	41.8	7.09
	27	21.2	3.17	25.4	3.89	29.4	4.69	31.5	5.12	33.6	5.58	37.6	6.54	41.8	7.58
	29	21.2	3.36	25.4	4.13	29.4	4.99	31.5	5.46	33.6	5.93	37.6	6.97	41.8	8.09
	31	21.2	3.55	25.4	4.38	29.4	5.31	31.5	5.80	33.6	6.32	37.6	7.43	41.8	8.63
	33	21.2	3.77	25.4	4.66	29.4	5.65	31.5	6.17	33.6	6.73	37.6	7.92	41.8	9.20
35	21.2	4.00	25.4	4.94	29.4	5.99	31.5	6.57	33.6	7.16	37.6	8.44	41.8	9.81	
37	21.2	4.22	25.4	5.24	29.4	6.38	31.5	6.97	33.6	7.62	37.6	8.98	41.8	10.45	
39	21.2	4.47	25.4	5.55	29.4	6.76	31.5	7.41	33.6	8.09	37.6	9.54	41.8	11.13	
41	21.2	4.67	25.4	5.75	29.4	6.96	31.5	7.66	33.6	8.34	37.6	9.94	41.8	11.62	
43	21.2	5.05	25.4	6.14	29.4	7.25	31.5	8.07	33.6	8.59	37.6	10.30	41.8	11.98	
45	21.2	5.16	25.4	6.27	29.4	7.40	31.5	8.20	33.6	9.01	37.6	10.86	41.8	12.44	
48	21.2	5.29	25.4	6.33	29.4	7.48	31.5	8.34	33.6	9.26	37.6	11.35	41.8	12.74	
60%	-5	18.2	2.05	21.7	2.37	25.2	2.77	27.0	2.95	28.8	3.18	32.3	3.57	35.8	4.10
	-2	18.2	2.06	21.7	2.41	25.2	2.82	27.0	2.99	28.8	3.21	32.3	3.63	35.8	4.12
	0	18.2	2.09	21.7	2.44	25.2	2.85	27.0	3.03	28.8	3.27	32.3	3.68	35.8	4.18
	2	18.2	2.13	21.7	2.50	25.2	2.91	27.0	3.09	28.8	3.31	32.3	3.75	35.8	4.23
	4	18.2	2.19	21.7	2.54	25.2	2.96	27.0	3.12	28.8	3.36	32.3	3.81	35.8	4.29
	6	18.2	2.21	21.7	2.59	25.2	3.02	27.0	3.19	28.8	3.43	32.3	3.89	35.8	4.39
	8	18.2	2.25	21.7	2.64	25.2	3.07	27.0	3.25	28.8	3.50	32.3	3.96	35.8	4.46
	10	18.2	2.29	21.7	2.69	25.2	3.12	27.0	3.34	28.8	3.57	32.3	4.04	35.8	4.53
	12	18.2	2.34	21.7	2.74	25.2	3.18	27.0	3.40	28.8	3.62	32.3	4.11	35.8	4.60
	14	18.2	2.37	21.7	2.78	25.2	3.23	27.0	3.46	28.8	3.70	32.3	4.19	35.8	4.69
	16	18.2	2.40	21.7	2.83	25.2	3.28	27.0	3.52	28.8	3.76	32.3	4.26	35.8	4.78
	18	18.2	2.44	21.7	2.87	25.2	3.34	27.0	3.58	28.8	3.83	32.3	4.34	35.8	4.87
	20	18.2	2.47	21.7	2.93	25.2	3.40	27.0	3.65	28.8	3.91	32.3	4.42	35.8	4.97
	21	18.2	2.50	21.7	2.94	25.2	3.43	27.0	3.68	28.8	3.94	32.3	4.47	35.8	5.02
	23	18.2	2.53	21.7	3.00	25.2	3.49	27.0	3.76	28.8	4.01	32.3	4.65	35.8	5.34
	25	18.2	2.57	21.7	3.05	25.2	3.62	27.0	3.94	28.8	4.26	32.3	4.96	35.8	5.70
	27	18.2	2.68	21.7	3.24	25.2	3.86	27.0	4.20	28.8	4.54	32.3	5.28	35.8	6.08
	29	18.2	2.83	21.7	3.43	25.2	4.11	27.0	4.47	28.8	4.84	32.3	5.64	35.8	6.50
	31	18.2	3.00	21.7	3.64	25.2	4.36	27.0	4.75	28.8	5.15	32.3	5.99	35.8	6.91
	33	18.2	3.17	21.7	3.86	25.2	4.63	27.0	5.05	28.8	5.47	32.3	6.38	35.8	7.37
35	18.2	3.36	21.7	4.10	25.2	4.91	27.0	5.36	28.8	5.81	32.3	6.79	35.8	7.84	
37	18.2	3.55	21.7	4.34	25.2	5.21	27.0	5.68	28.8	6.17	32.3	7.22	35.8	8.34	
39	18.2	3.74	21.7	4.59	25.2	5.52	27.0	6.02	28.8	6.55	32.3	7.66	35.8	8.88	
41	18.2	3.86	21.7	4.78	25.2	5.72	27.0	6.26	28.8	6.80	32.3	8.03	35.8	9.28	
43	18.2	3.98	21.7	4.99	25.2	5.92	27.0	6.45	28.8	7.03	32.3	8.37	35.8	9.68	
45	18.2	4.17	21.7	5.24	25.2	6.16	27.0	6.69	28.8	7.38	32.3	8.74	35.8	10.22	
48	18.2	4.33	21.7	5.47	25.2	6.37	27.0	6.87	28.8	7.67	32.3	9.06	35.8	10.70	

Abbreviations:

CR: Combination ratio

TC: Total capacity (kW)

PI: Power input (compressor + outdoor fan motor) (kW)

Notes:

1. Shaded cells indicate rating condition.

Table continued on next page ...

# VMEX 460V 60Hz

Table 2-8.5: VMEX014Q8A-D26V450 cooling capacity (continued)

CR	Outdoor air temp. (°C DB)	Indoor air temp. (°C DB / °C WB)													
		20.8 / 14.0		23.3 / 16.0		25.8 / 18.0		27.0 / 19.0		28.2 / 20.0		30.7 / 22.0		32.0 / 24.0	
		TC	PI	TC	PI	TC	PI	TC	PI	TC	PI	TC	PI	TC	PI
		kW	kW	kW	kW	kW	kW	kW	kW	kW	kW	kW	kW	kW	kW
50%	-5	15.2	1.78	18.2	2.05	21.1	2.36	22.5	2.47	23.9	2.61	26.8	2.97	29.9	3.20
	-2	15.2	1.79	18.2	2.10	21.1	2.39	22.5	2.51	23.9	2.65	26.8	3.00	29.9	3.24
	0	15.2	1.82	18.2	2.13	21.1	2.43	22.5	2.54	23.9	2.68	26.8	3.06	29.9	3.29
	2	15.2	1.85	18.2	2.16	21.1	2.47	22.5	2.58	23.9	2.73	26.8	3.07	29.9	3.36
	4	15.2	1.86	18.2	2.19	21.1	2.50	22.5	2.61	23.9	2.79	26.8	3.14	29.9	3.44
	6	15.2	1.90	18.2	2.23	21.1	2.54	22.5	2.67	23.9	2.84	26.8	3.19	29.9	3.55
	8	15.2	1.94	18.2	2.27	21.1	2.58	22.5	2.73	23.9	2.88	26.8	3.24	29.9	3.66
	10	15.2	1.98	18.2	2.29	21.1	2.62	22.5	2.77	23.9	2.96	26.8	3.33	29.9	3.71
	12	15.2	2.00	18.2	2.32	21.1	2.66	22.5	2.83	23.9	3.02	26.8	3.39	29.9	3.77
	14	15.2	2.03	18.2	2.35	21.1	2.69	22.5	2.89	23.9	3.06	26.8	3.45	29.9	3.85
	16	15.2	2.06	18.2	2.38	21.1	2.74	22.5	2.93	23.9	3.11	26.8	3.51	29.9	3.91
	18	15.2	2.09	18.2	2.43	21.1	2.78	22.5	2.97	23.9	3.17	26.8	3.57	29.9	3.98
	20	15.2	2.12	18.2	2.46	21.1	2.83	22.5	3.02	23.9	3.23	26.8	3.63	29.9	4.05
	21	15.2	2.13	18.2	2.49	21.1	2.86	22.5	3.05	23.9	3.26	26.8	3.67	29.9	4.10
	23	15.2	2.16	18.2	2.52	21.1	2.90	22.5	3.11	23.9	3.31	26.8	3.73	29.9	4.19
	25	15.2	2.19	18.2	2.56	21.1	2.96	22.5	3.17	23.9	3.42	26.8	3.92	29.9	4.47
	27	15.2	2.23	18.2	2.66	21.1	3.12	22.5	3.37	23.9	3.63	26.8	4.17	29.9	4.76
	29	15.2	2.35	18.2	2.81	21.1	3.31	22.5	3.58	23.9	3.86	26.8	4.44	29.9	5.08
	31	15.2	2.49	18.2	2.97	21.1	3.51	22.5	3.80	23.9	4.10	26.8	4.72	29.9	5.40
	33	15.2	2.63	18.2	3.15	21.1	3.73	22.5	4.02	23.9	4.35	26.8	5.02	29.9	5.74
35	15.2	2.78	18.2	3.33	21.1	3.94	22.5	4.26	23.9	4.60	26.8	5.33	29.9	6.10	
37	15.2	2.93	18.2	3.52	21.1	4.17	22.5	4.51	23.9	4.88	26.8	5.65	29.9	6.48	
39	15.2	3.09	18.2	3.71	21.1	4.41	22.5	4.78	23.9	5.18	26.8	5.99	29.9	6.88	
41	15.2	3.22	18.2	3.87	21.1	4.57	22.5	5.00	23.9	5.40	26.8	6.31	29.9	7.20	
43	15.2	3.43	18.2	4.14	21.1	4.73	22.5	5.23	23.9	5.54	26.8	6.63	29.9	7.52	
45	15.2	3.51	18.2	4.25	21.1	5.05	22.5	5.63	23.9	5.78	26.8	7.27	29.9	8.16	
48	15.2	3.59	18.2	4.37	21.1	5.35	22.5	5.99	23.9	6.03	26.8	7.86	29.9	8.78	

Abbreviations:

CR: Combination ratio

TC: Total capacity (kW)

PI: Power input (compressor + outdoor fan motor) (kW)

Notes:

1. Shaded cells indicate rating condition.

Table 2-8.6: VMEX016Q8A-D29V500 cooling capacity

CR	Outdoor air temp. (°C DB)	Indoor air temp. (°C DB / °C WB)													
		20.8 / 14.0		23.3 / 16.0		25.8 / 18.0		27.0 / 19.0		28.2 / 20.0		30.7 / 22.0		32.0 / 24.0	
		TC	PI	TC	PI	TC	PI	TC	PI	TC	PI	TC	PI	TC	PI
		kW	kW	kW	kW	kW	kW	kW	kW	kW	kW	kW	kW	kW	kW
130%	-5	43.9	5.24	52.3	6.40	60.7	6.86	63.0	7.14	66.1	7.34	67.7	7.98	69.4	8.03
	-2	43.9	5.24	52.3	6.52	60.7	6.86	63.0	7.18	66.1	7.34	67.7	8.08	69.4	8.11
	0	43.9	5.33	52.3	6.63	60.7	7.11	63.0	7.57	66.1	7.76	67.7	8.18	69.4	8.22
	2	43.9	5.43	52.3	6.65	60.7	7.35	63.0	8.00	66.1	7.85	67.7	8.24	69.4	8.34
	4	43.9	5.55	52.3	6.78	60.7	7.60	63.0	8.03	66.1	7.96	67.7	8.36	69.4	8.50
	6	43.9	5.65	52.3	6.91	60.7	7.89	63.0	8.10	65.3	8.20	66.8	8.49	68.6	8.56
	8	43.9	5.79	52.3	7.07	60.7	8.28	63.0	8.49	64.5	8.47	66.1	8.52	67.7	8.64
	10	43.9	5.91	52.3	7.22	60.7	8.59	63.0	8.78	63.7	8.63	65.4	8.65	67.0	8.89
	12	43.9	6.01	52.3	7.36	60.7	8.76	62.1	8.91	63.0	8.76	64.5	8.78	66.1	8.95
	14	43.9	6.13	52.3	7.50	60.5	8.89	61.4	9.04	62.1	8.89	63.7	8.91	65.4	9.15
	16	43.9	6.24	52.3	7.65	59.8	9.02	60.5	9.16	61.2	9.15	62.9	9.04	64.5	9.30
	18	43.9	6.36	52.3	7.81	58.9	9.16	59.6	9.21	60.5	9.26	62.1	9.35	63.7	9.43
	20	43.9	6.50	52.3	8.31	58.0	9.61	58.9	9.66	59.6	9.71	61.2	9.80	62.9	9.90
	21	43.9	6.67	52.3	8.61	57.7	9.83	58.6	9.88	59.3	9.94	60.9	10.04	62.5	10.13
	23	43.9	7.15	52.3	9.23	57.0	10.28	57.7	10.33	58.4	10.38	60.0	10.49	61.6	10.59
	25	43.9	7.64	52.3	9.88	56.1	10.73	56.8	10.78	57.7	10.85	59.3	10.95	60.9	11.06
	27	43.9	8.16	52.3	10.58	55.4	11.18	56.1	11.25	56.8	11.30	58.4	11.42	60.0	11.54
	29	43.9	8.71	52.3	11.30	54.5	11.63	55.2	11.70	56.1	11.77	57.7	11.89	59.3	12.01
	31	43.9	9.30	52.1	11.96	53.6	12.10	54.5	12.16	55.2	12.22	56.8	12.35	58.4	12.49
	33	43.9	9.90	51.2	12.41	52.9	12.54	53.6	12.61	54.5	12.68	56.1	12.82	57.5	12.96
35	43.9	10.56	50.4	12.86	52.0	13.01	52.9	13.08	53.6	13.15	55.2	13.31	56.8	13.44	
37	43.9	11.23	49.6	13.32	51.2	13.48	52.0	13.55	52.9	13.63	54.3	13.79	55.9	13.94	
39	43.9	11.96	48.7	13.46	50.4	13.93	51.2	14.01	52.0	14.10	53.6	14.25	55.2	14.43	
41	43.9	12.58	48.2	13.59	49.8	14.06	50.7	14.14	51.4	14.23	53.0	14.28	53.1	14.56	
43	43.9	12.90	47.9	13.66	49.6	14.10	50.5	14.21	50.9	14.25	52.1	14.31	52.4	14.59	
45	43.9	13.55	47.6	13.79	49.0	14.23	49.9	14.30	50.2	14.32	50.7	14.36	51.4	14.87	
48	43.9	14.03	47.4	14.23	48.2	14.36	49.1	14.43	49.5	14.48	49.3	14.61	50.2	14.91	
120%	-5	40.5	5.06	48.2	6.13	56.1	7.25	60.0	7.91	62.9	8.24	64.3	8.51	65.7	8.73
	-2	40.5	5.11	48.2	6.20	56.1	7.32	60.0	7.95	62.9	8.34	64.3	8.58	65.7	8.76
	0	40.5	5.16	48.2	6.24	56.1	7.41	60.0	7.97	62.9	8.41	64.3	8.63	65.7	8.78
	2	40.5	5.17	48.2	6.30	56.1	7.46	60.0	8.05	62.9	8.45	64.3	8.69	65.7	8.80
	4	40.5	5.22	48.2	6.38	56.1	7.56	60.0	8.12	62.9	8.56	64.3	8.71	65.7	8.82
	6	40.5	5.28	48.2	6.43	56.1	7.65	60.0	8.21	62.9	8.65	64.3	8.78	65.7	8.85
	8	40.5	5.33	48.2	6.50	56.1	7.76	60.0	8.32	62.9	8.74	64.3	8.81	65.7	8.89
	10	40.5	5.39	48.2	6.58	56.1	7.83	60.0	8.47	62.9	8.74	64.3	8.84	65.7	8.93
	12	40.5	5.49	48.2	6.70	56.1	7.98	60.0	8.62	62.0	8.78	63.4	8.79	64.8	8.99
	14	40.5	5.60	48.2	6.84	56.1	8.14	60.0	8.80	61.1	8.84	62.7	8.92	64.1	9.10
	16	40.5	5.70	48.2	6.98	56.1	8.29	59.6	8.95	60.4	8.97	61.8	9.07	63.2	9.23
	18	40.5	5.81	48.2	7.12	56.1	8.57	58.8	9.16	59.5	9.19	60.9	9.28	62.5	9.36
	20	40.5	5.93	48.2	7.39	56.1	9.23	58.0	9.61	58.8	9.64	60.2	9.73	61.6	9.81
	21	40.5	5.98	48.2	7.65	56.1	9.56	57.5	9.83	58.2	9.87	59.8	9.95	61.3	10.06
	23	40.5	6.39	48.2	8.21	56.1	10.23	56.8	10.26	57.5	10.32	58.9	10.42	60.4	10.50
	25	40.5	6.83	48.2	8.78	55.2	10.68	55.9	10.71	56.6	10.76	58.2	10.87	59.6	10.97
	27	40.5	7.29	48.2	9.38	54.5	11.11	55.2	11.18	55.9	11.23	57.3	11.33	58.8	11.44
	29	40.5	7.78	48.2	10.02	53.6	11.56	54.3	11.63	55.0	11.68	56.4	11.80	58.0	11.90
	31	40.5	8.29	48.2	10.69	52.7	12.03	53.6	12.08	54.3	12.15	55.7	12.27	57.1	12.39
	33	40.5	8.83	48.2	11.40	52.0	12.47	52.7	12.54	53.4	12.60	54.8	12.73	56.2	12.86
35	40.5	9.40	48.2	12.16	51.1	12.92	51.8	12.99	52.7	13.06	54.1	13.20	55.5	13.34	
37	40.5	10.00	48.2	12.96	50.4	13.39	51.1	13.46	51.8	13.53	53.2	13.67	54.6	13.82	
39	40.5	10.64	48.0	13.68	49.5	13.84	50.2	13.93	50.9	14.00	52.5	14.15	53.9	14.29	
41	40.5	10.93	47.6	13.78	49.1	13.94	49.8	14.02	50.5	14.09	52.1	14.19	52.4	14.40	
43	40.5	11.10	47.4	13.88	48.7	14.02	49.4	14.08	50.1	14.14	51.2	14.23	51.6	14.68	
45	40.5	11.23	47.1	14.01	48.2	14.15	48.9	14.21	49.7	14.25	50.2	14.27	51.0	15.00	
48	40.5	11.32	46.7	14.16	47.6	14.28	48.1	14.31	49.1	14.37	49.4	14.33	50.4	15.19	

Abbreviations:

CR: Combination ratio

TC: Total capacity (kW)

PI: Power input (compressor + outdoor fan motor) (kW)

Notes:

1. Shaded cells indicate rating condition.

Table continued on next page ...

# VMEX 460V 60Hz

Table 2-8.6: VMEX016Q8A-D29V500 cooling capacity (continued)

CR	Outdoor air temp. (°C DB)	Indoor air temp. (°C DB / °C WB)													
		20.8 / 14.0		23.3 / 16.0		25.8 / 18.0		27.0 / 19.0		28.2 / 20.0		30.7 / 22.0		32.0 / 24.0	
		TC	PI	TC	PI	TC	PI	TC	PI	TC	PI	TC	PI	TC	PI
		kW	kW	kW	kW	kW	kW	kW	kW	kW	kW	kW	kW	kW	kW
110%	-5	37.1	4.42	44.3	5.50	51.4	6.57	55.0	7.05	58.6	7.58	63.0	7.88	64.5	8.12
	-2	37.1	4.50	44.3	5.57	51.4	6.62	55.0	7.12	58.6	7.64	63.0	7.95	64.5	8.16
	0	37.1	4.55	44.3	5.61	51.4	6.67	55.0	7.16	58.6	7.73	63.0	8.03	64.5	8.26
	2	37.1	4.65	44.3	5.66	51.4	6.78	55.0	7.24	58.6	7.81	63.0	8.15	64.5	8.36
	4	37.1	4.74	44.3	5.72	51.4	6.84	55.0	7.33	58.6	7.93	63.0	8.26	64.5	8.44
	6	37.1	4.79	44.3	5.79	51.4	6.91	55.0	7.45	58.6	8.02	63.0	8.35	64.5	8.57
	8	37.1	4.83	44.3	5.88	51.4	6.99	55.0	7.52	58.6	8.11	63.0	8.40	64.5	8.66
	10	37.1	4.89	44.3	5.96	51.4	7.08	55.0	7.65	58.6	8.24	63.0	8.46	64.5	8.74
	12	37.1	4.99	44.3	6.08	51.4	7.22	55.0	7.81	58.6	8.40	62.3	8.59	63.6	8.85
	14	37.1	5.08	44.3	6.19	51.4	7.36	55.0	7.95	58.6	8.55	61.4	8.66	62.9	8.91
	16	37.1	5.17	44.3	6.31	51.4	7.50	55.0	8.10	58.6	8.73	60.7	8.76	62.0	9.01
	18	37.1	5.27	44.3	6.43	51.4	7.65	55.0	8.33	58.6	9.14	59.8	9.21	61.3	9.30
	20	37.1	5.37	44.3	6.57	51.4	8.10	55.0	8.95	57.7	9.59	59.1	9.66	60.4	9.74
	21	37.1	5.42	44.3	6.76	51.4	8.40	55.0	9.28	57.3	9.81	58.6	9.88	60.0	9.97
	23	37.1	5.68	44.3	7.24	51.4	9.00	55.0	9.95	56.4	10.25	57.9	10.35	59.1	10.44
	25	37.1	6.07	44.3	7.74	51.4	9.62	55.0	10.66	55.7	10.69	57.0	10.80	58.4	10.89
	27	37.1	6.46	44.3	8.28	51.4	10.30	54.1	11.11	54.8	11.15	56.3	11.25	57.5	11.35
	29	37.1	6.89	44.3	8.83	51.4	11.01	53.4	11.56	54.1	11.61	55.4	11.71	56.8	11.82
	31	37.1	7.34	44.3	9.42	51.4	11.75	52.5	12.01	53.2	12.06	54.6	12.16	55.9	12.29
	33	37.1	7.81	44.3	10.04	51.1	12.39	51.8	12.46	52.5	12.51	53.8	12.63	55.2	12.75
35	37.1	8.31	44.3	10.69	50.2	12.84	50.9	12.91	51.6	12.98	52.9	13.10	54.3	13.22	
37	37.1	8.85	44.3	11.39	49.5	13.30	50.2	13.36	50.7	13.43	52.1	13.56	53.4	13.68	
39	37.1	9.40	44.3	12.13	48.6	13.75	49.3	13.82	50.0	13.89	51.3	14.03	52.7	14.17	
41	37.1	9.50	44.3	12.23	48.2	13.85	48.9	13.92	49.6	13.99	50.6	14.13	51.1	14.27	
43	37.1	9.59	44.3	12.38	47.8	13.95	48.5	14.02	49.2	14.09	50.1	14.18	50.3	14.56	
45	37.1	9.90	44.3	12.45	47.3	14.08	48.0	14.19	48.8	14.21	49.6	14.57	49.8	14.89	
48	37.1	10.25	44.3	13.51	46.6	14.17	47.3	14.29	48.2	14.36	48.8	14.62	49.2	15.05	
100%	-5	33.8	4.03	40.2	4.85	46.8	5.77	50.0	6.18	53.2	6.70	59.8	7.64	63.2	7.97
	-2	33.8	4.07	40.2	4.91	46.8	5.83	50.0	6.29	53.2	6.79	59.8	7.73	63.2	8.03
	0	33.8	4.12	40.2	4.96	46.8	5.90	50.0	6.37	53.2	6.86	59.8	7.86	63.2	8.12
	2	33.8	4.20	40.2	5.03	46.8	5.96	50.0	6.45	53.2	6.94	59.8	7.97	63.2	8.24
	4	33.8	4.23	40.2	5.08	46.8	6.05	50.0	6.55	53.2	7.03	59.8	8.05	63.2	8.33
	6	33.8	4.29	40.2	5.18	46.8	6.13	50.0	6.67	53.2	7.13	59.8	8.17	63.2	8.46
	8	33.8	4.37	40.2	5.26	46.8	6.24	50.0	6.74	53.2	7.24	59.8	8.29	63.2	8.60
	10	33.8	4.42	40.2	5.36	46.8	6.34	50.0	6.86	53.2	7.38	59.8	8.43	63.2	8.73
	12	33.8	4.49	40.2	5.46	46.8	6.46	50.0	6.98	53.2	7.52	59.8	8.59	62.3	8.79
	14	33.8	4.58	40.2	5.56	46.8	6.58	50.0	7.12	53.2	7.65	59.8	8.76	61.6	8.90
	16	33.8	4.67	40.2	5.67	46.8	6.72	50.0	7.26	53.2	7.81	59.5	8.86	60.7	9.00
	18	33.8	4.75	40.2	5.77	46.8	6.84	50.0	7.39	53.2	7.97	58.8	9.16	60.0	9.23
	20	33.8	4.84	40.2	5.89	46.8	7.05	50.0	7.77	53.2	8.54	57.9	9.59	59.1	9.68
	21	33.8	4.89	40.2	5.94	46.8	7.31	50.0	8.05	53.2	8.83	57.5	9.81	58.8	9.90
	23	33.8	5.01	40.2	6.34	46.8	7.83	50.0	8.62	53.2	9.47	56.8	10.26	57.9	10.35
	25	33.8	5.34	40.2	6.77	46.8	8.38	50.0	9.24	53.2	10.14	55.9	10.71	57.1	10.80
	27	33.8	5.70	40.2	7.22	46.8	8.95	50.0	9.88	53.2	10.85	55.0	11.16	56.3	11.26
	29	33.8	6.06	40.2	7.71	46.8	9.55	50.0	10.56	53.0	11.52	54.3	11.63	55.5	11.71
	31	33.8	6.46	40.2	8.22	46.8	10.19	50.0	11.26	52.3	11.97	53.4	12.08	54.6	12.18
	33	33.8	6.86	40.2	8.76	46.8	10.87	50.0	12.03	51.4	12.42	52.7	12.53	53.9	12.65
35	33.8	7.29	40.2	9.31	46.8	11.59	<b>50.0</b>	<b>12.82</b>	50.5	12.87	51.8	12.99	53.0	13.10	
37	33.8	7.76	40.2	9.92	46.8	12.35	49.1	13.27	49.8	13.34	51.1	13.46	52.1	13.56	
39	33.8	8.24	40.2	10.54	46.8	13.15	48.4	13.72	48.9	13.79	50.2	13.91	51.4	14.05	
41	33.8	8.63	40.2	10.92	46.8	13.63	47.6	13.81	48.6	14.00	49.3	14.24	50.7	14.34	
43	33.8	9.01	40.2	11.31	46.8	13.88	46.9	13.98	48.2	14.13	49.6	14.33	49.8	14.50	
45	33.8	9.52	40.2	11.82	46.8	14.12	45.9	14.17	48.0	14.39	49.2	14.55	48.8	14.69	
48	33.8	9.94	40.2	12.24	46.8	14.14	44.0	14.33	47.9	14.65	46.2	14.70	47.7	14.83	

Abbreviations:

CR: Combination ratio

TC: Total capacity (kW)

PI: Power input (compressor + outdoor fan motor) (kW)

Notes:

1. Shaded cells indicate rating condition.

Table continued on next page ...

Table 2-8.6: VMEX016Q8A-D29V500 cooling capacity (continued)

CR	Outdoor air temp. (°C DB)	Indoor air temp. (°C DB / °C WB)													
		20.8 / 14.0		23.3 / 16.0		25.8 / 18.0		27.0 / 19.0		28.2 / 20.0		30.7 / 22.0		32.0 / 24.0	
		TC	PI	TC	PI	TC	PI	TC	PI	TC	PI	TC	PI	TC	PI
		kW	kW	kW	kW	kW	kW	kW	kW	kW	kW	kW	kW	kW	kW
90%	-5	30.4	3.56	36.3	4.27	42.1	5.04	45.0	5.50	47.9	5.85	53.7	6.73	59.6	7.70
	-2	30.4	3.59	36.3	4.32	42.1	5.10	45.0	5.58	47.9	5.92	53.7	6.79	59.6	7.78
	0	30.4	3.65	36.3	4.37	42.1	5.18	45.0	5.64	47.9	6.00	53.7	6.87	59.6	7.84
	2	30.4	3.70	36.3	4.43	42.1	5.24	45.0	5.73	47.9	6.09	53.7	7.01	59.6	7.95
	4	30.4	3.76	36.3	4.49	42.1	5.32	45.0	5.81	47.9	6.17	53.7	7.12	59.6	8.07
	6	30.4	3.81	36.3	4.58	42.1	5.42	45.0	5.91	47.9	6.28	53.7	7.23	59.6	8.20
	8	30.4	3.88	36.3	4.67	42.1	5.53	45.0	5.99	47.9	6.38	53.7	7.36	59.6	8.28
	10	30.4	3.96	36.3	4.77	42.1	5.63	45.0	6.08	47.9	6.53	53.7	7.46	59.6	8.41
	12	30.4	4.03	36.3	4.85	42.1	5.74	45.0	6.18	47.9	6.65	53.7	7.60	59.6	8.57
	14	30.4	4.09	36.3	4.94	42.1	5.84	45.0	6.31	47.9	6.77	53.7	7.74	59.6	8.72
	16	30.4	4.16	36.3	5.03	42.1	5.96	45.0	6.43	47.9	6.91	53.7	7.90	59.5	8.88
	18	30.4	4.23	36.3	5.13	42.1	6.06	45.0	6.55	47.9	7.05	53.7	8.05	58.8	9.16
	20	30.4	4.32	36.3	5.25	42.1	6.19	45.0	6.69	47.9	7.31	53.7	8.66	57.9	9.59
	21	30.4	4.35	36.3	5.29	42.1	6.29	45.0	6.91	47.9	7.57	53.7	8.97	57.5	9.81
	23	30.4	4.44	36.3	5.49	42.1	6.74	45.0	7.41	47.9	8.12	53.7	9.62	56.6	10.26
	25	30.4	4.68	36.3	5.87	42.1	7.20	45.0	7.93	47.9	8.67	53.7	10.30	55.9	10.71
	27	30.4	4.98	36.3	6.25	42.1	7.69	45.0	8.47	47.9	9.28	53.7	11.02	55.0	11.16
	29	30.4	5.30	36.3	6.67	42.1	8.21	45.0	9.04	47.9	9.92	53.2	11.52	54.3	11.61
	31	30.4	5.63	36.3	7.10	42.1	8.74	45.0	9.64	47.9	10.57	52.3	11.97	53.4	12.08
	33	30.4	5.98	36.3	7.55	42.1	9.33	45.0	10.28	47.9	11.28	51.6	12.44	52.7	12.53
35	30.4	6.36	36.3	8.03	42.1	9.93	45.0	10.95	47.9	12.02	50.7	12.89	51.8	12.99	
37	30.4	6.74	36.3	8.53	42.1	10.57	45.0	11.66	47.9	12.82	49.8	13.34	51.1	13.44	
39	30.4	7.15	36.3	9.09	42.1	11.25	45.0	12.42	47.9	13.65	49.1	13.80	50.2	13.91	
41	30.4	7.40	36.3	9.50	42.1	11.66	45.0	12.75	47.9	13.73	48.8	14.16	49.8	14.24	
43	30.4	7.76	36.3	9.91	42.1	12.07	45.0	13.08	47.9	14.02	48.5	14.34	49.4	14.46	
45	30.4	8.25	36.3	10.40	42.1	12.56	45.0	13.52	47.9	14.41	48.2	14.49	48.7	14.65	
48	30.4	8.71	36.3	10.88	42.1	13.04	45.0	13.69	47.9	14.54	47.8	14.69	47.3	14.85	
80%	-5	27.0	3.14	32.1	3.71	37.3	4.39	40.0	4.67	42.7	5.03	47.9	5.81	53.0	6.63
	-2	27.0	3.18	32.1	3.76	37.3	4.43	40.0	4.74	42.7	5.07	47.9	5.87	53.0	6.70
	0	27.0	3.24	32.1	3.80	37.3	4.48	40.0	4.80	42.7	5.17	47.9	5.95	53.0	6.79
	2	27.0	3.30	32.1	3.86	37.3	4.55	40.0	4.89	42.7	5.26	47.9	6.07	53.0	6.92
	4	27.0	3.36	32.1	3.92	37.3	4.63	40.0	5.00	42.7	5.35	47.9	6.18	53.0	7.01
	6	27.0	3.41	32.1	4.01	37.3	4.71	40.0	5.11	42.7	5.45	47.9	6.27	53.0	7.13
	8	27.0	3.48	32.1	4.11	37.3	4.82	40.0	5.19	42.7	5.57	47.9	6.37	53.0	7.27
	10	27.0	3.51	32.1	4.20	37.3	4.94	40.0	5.32	42.7	5.70	47.9	6.51	53.0	7.34
	12	27.0	3.56	32.1	4.27	37.3	5.03	40.0	5.43	42.7	5.82	47.9	6.63	53.0	7.48
	14	27.0	3.63	32.1	4.35	37.3	5.11	40.0	5.51	42.7	5.93	47.9	6.76	53.0	7.62
	16	27.0	3.68	32.1	4.42	37.3	5.22	40.0	5.62	42.7	6.03	47.9	6.89	53.0	7.76
	18	27.0	3.75	32.1	4.51	37.3	5.32	40.0	5.74	42.7	6.15	47.9	7.03	53.0	7.91
	20	27.0	3.82	32.1	4.60	37.3	5.43	40.0	5.84	42.7	6.27	47.9	7.29	53.0	8.47
	21	27.0	3.85	32.1	4.63	37.3	5.48	40.0	5.91	42.7	6.41	47.9	7.55	53.0	8.78
	23	27.0	3.92	32.1	4.73	37.3	5.74	40.0	6.29	42.7	6.86	47.9	8.09	53.0	9.42
	25	27.0	4.04	32.1	5.03	37.3	6.13	40.0	6.72	42.7	7.33	47.9	8.66	53.0	10.07
	27	27.0	4.30	32.1	5.36	37.3	6.53	40.0	7.17	42.7	7.83	47.9	9.24	53.0	10.78
	29	27.0	4.58	32.1	5.70	37.3	6.96	40.0	7.64	42.7	8.36	47.9	9.87	53.0	11.52
	31	27.0	4.86	32.1	6.06	37.3	7.41	40.0	8.14	42.7	8.92	47.9	10.54	52.1	11.97
	33	27.0	5.17	32.1	6.44	37.3	7.90	40.0	8.67	42.7	9.49	47.9	11.23	51.4	12.42
35	27.0	5.48	32.1	6.86	37.3	8.40	40.0	9.23	42.7	10.11	47.9	11.97	50.5	12.87	
37	27.0	5.81	32.1	7.27	37.3	8.93	40.0	9.83	42.7	10.76	47.9	12.77	49.8	13.32	
39	27.0	6.15	32.1	7.76	37.3	9.50	40.0	10.45	42.7	11.46	47.9	13.60	48.9	13.79	
41	27.0	6.29	32.1	7.83	37.3	9.64	40.0	10.73	42.7	11.66	47.9	13.94	48.6	14.03	
43	27.0	6.47	32.1	7.90	37.3	9.78	40.0	10.92	42.7	11.82	47.9	14.11	48.3	14.18	
45	27.0	6.66	32.1	7.99	37.3	9.97	40.0	11.15	42.7	12.03	47.9	14.26	47.7	14.41	
48	27.0	6.88	32.1	8.04	37.3	10.13	40.0	11.30	42.7	12.13	47.9	14.40	47.3	14.61	

Abbreviations:

CR: Combination ratio

TC: Total capacity (kW)

PI: Power input (compressor + outdoor fan motor) (kW)

Notes:

1. Shaded cells indicate rating condition.

Table continued on next page ...

# VMEX 460V 60Hz

Table 2-8.6: VMEX016Q8A-D29V500 cooling capacity (continued)

CR	Outdoor air temp. (°C DB)	Indoor air temp. (°C DB / °C WB)													
		20.8 / 14.0		23.3 / 16.0		25.8 / 18.0		27.0 / 19.0		28.2 / 20.0		30.7 / 22.0		32.0 / 24.0	
		TC	PI	TC	PI	TC	PI	TC	PI	TC	PI	TC	PI	TC	PI
		kW	kW	kW	kW	kW	kW	kW	kW	kW	kW	kW	kW	kW	kW
70%	-5	23.6	2.80	28.2	3.28	32.7	3.72	35.0	3.99	37.3	4.26	41.8	4.87	46.4	5.60
	-2	23.6	2.82	28.2	3.30	32.7	3.74	35.0	4.07	37.3	4.33	41.8	4.95	46.4	5.68
	0	23.6	2.84	28.2	3.34	32.7	3.82	35.0	4.14	37.3	4.41	41.8	5.05	46.4	5.75
	2	23.6	2.85	28.2	3.36	32.7	3.88	35.0	4.22	37.3	4.49	41.8	5.16	46.4	5.85
	4	23.6	2.89	28.2	3.44	32.7	3.97	35.0	4.30	37.3	4.59	41.8	5.24	46.4	5.98
	6	23.6	2.94	28.2	3.50	32.7	4.07	35.0	4.43	37.3	4.69	41.8	5.33	46.4	6.10
	8	23.6	2.99	28.2	3.61	32.7	4.16	35.0	4.50	37.3	4.79	41.8	5.49	46.4	6.21
	10	23.6	3.05	28.2	3.66	32.7	4.27	35.0	4.60	37.3	4.92	41.8	5.60	46.4	6.29
	12	23.6	3.13	28.2	3.71	32.7	4.35	35.0	4.68	37.3	5.01	41.8	5.70	46.4	6.41
	14	23.6	3.18	28.2	3.78	32.7	4.42	35.0	4.75	37.3	5.10	41.8	5.81	46.4	6.53
	16	23.6	3.23	28.2	3.85	32.7	4.51	35.0	4.86	37.3	5.20	41.8	5.91	46.4	6.65
	18	23.6	3.28	28.2	3.92	32.7	4.60	35.0	4.94	37.3	5.29	41.8	6.03	46.4	6.79
	20	23.6	3.33	28.2	3.99	32.7	4.68	35.0	5.03	37.3	5.39	41.8	6.15	46.4	6.98
	21	23.6	3.37	28.2	4.03	32.7	4.72	35.0	5.08	37.3	5.44	41.8	6.24	46.4	7.22
	23	23.6	3.42	28.2	4.10	32.7	4.82	35.0	5.25	37.3	5.72	41.8	6.69	46.4	7.74
	25	23.6	3.49	28.2	4.27	32.7	5.13	35.0	5.62	37.3	6.10	41.8	7.15	46.4	8.28
	27	23.6	3.70	28.2	4.54	32.7	5.48	35.0	5.98	37.3	6.51	41.8	7.64	46.4	8.85
	29	23.6	3.92	28.2	4.82	32.7	5.82	35.0	6.38	37.3	6.93	41.8	8.14	46.4	9.45
	31	23.6	4.15	28.2	5.11	32.7	6.20	35.0	6.77	37.3	7.38	41.8	8.67	46.4	10.07
	33	23.6	4.41	28.2	5.44	32.7	6.60	35.0	7.21	37.3	7.86	41.8	9.24	46.4	10.75
35	23.6	4.67	28.2	5.77	32.7	7.00	35.0	7.67	37.3	8.36	41.8	9.85	46.4	11.46	
37	23.6	4.92	28.2	6.12	32.7	7.45	35.0	8.14	37.3	8.90	41.8	10.49	46.4	12.20	
39	23.6	5.22	28.2	6.48	32.7	7.90	35.0	8.66	37.3	9.45	41.8	11.14	46.4	12.99	
41	23.6	5.45	28.2	6.71	32.7	8.13	35.0	8.94	37.3	9.74	41.8	11.60	46.4	13.57	
43	23.6	5.89	28.2	7.17	32.7	8.46	35.0	9.42	37.3	10.03	41.8	12.03	46.4	13.99	
45	23.6	6.02	28.2	7.32	32.7	8.64	35.0	9.58	37.3	10.53	41.8	12.68	46.4	14.53	
48	23.6	6.18	28.2	7.39	32.7	8.73	35.0	9.73	37.3	10.81	41.8	13.25	46.4	14.87	
60%	-5	20.2	2.39	24.1	2.77	28.0	3.23	30.0	3.44	32.0	3.71	35.9	4.17	39.8	4.78
	-2	20.2	2.40	24.1	2.81	28.0	3.29	30.0	3.49	32.0	3.75	35.9	4.23	39.8	4.82
	0	20.2	2.44	24.1	2.85	28.0	3.33	30.0	3.53	32.0	3.81	35.9	4.30	39.8	4.88
	2	20.2	2.48	24.1	2.91	28.0	3.39	30.0	3.60	32.0	3.87	35.9	4.38	39.8	4.94
	4	20.2	2.55	24.1	2.97	28.0	3.46	30.0	3.65	32.0	3.92	35.9	4.45	39.8	5.01
	6	20.2	2.58	24.1	3.03	28.0	3.52	30.0	3.73	32.0	4.00	35.9	4.54	39.8	5.13
	8	20.2	2.63	24.1	3.08	28.0	3.59	30.0	3.80	32.0	4.08	35.9	4.63	39.8	5.21
	10	20.2	2.68	24.1	3.14	28.0	3.65	30.0	3.90	32.0	4.16	35.9	4.72	39.8	5.29
	12	20.2	2.73	24.1	3.20	28.0	3.71	30.0	3.97	32.0	4.23	35.9	4.80	39.8	5.37
	14	20.2	2.76	24.1	3.25	28.0	3.77	30.0	4.04	32.0	4.32	35.9	4.89	39.8	5.48
	16	20.2	2.80	24.1	3.30	28.0	3.84	30.0	4.11	32.0	4.39	35.9	4.98	39.8	5.58
	18	20.2	2.85	24.1	3.35	28.0	3.90	30.0	4.18	32.0	4.47	35.9	5.06	39.8	5.68
	20	20.2	2.88	24.1	3.42	28.0	3.97	30.0	4.27	32.0	4.56	35.9	5.17	39.8	5.80
	21	20.2	2.92	24.1	3.44	28.0	4.01	30.0	4.30	32.0	4.60	35.9	5.22	39.8	5.86
	23	20.2	2.95	24.1	3.51	28.0	4.08	30.0	4.39	32.0	4.68	35.9	5.42	39.8	6.24
	25	20.2	3.01	24.1	3.56	28.0	4.23	30.0	4.60	32.0	4.98	35.9	5.79	39.8	6.65
	27	20.2	3.13	24.1	3.78	28.0	4.51	30.0	4.91	32.0	5.30	35.9	6.17	39.8	7.10
	29	20.2	3.30	24.1	4.01	28.0	4.80	30.0	5.22	32.0	5.65	35.9	6.58	39.8	7.58
	31	20.2	3.51	24.1	4.25	28.0	5.10	30.0	5.55	32.0	6.01	35.9	7.00	39.8	8.07
	33	20.2	3.70	24.1	4.51	28.0	5.41	30.0	5.89	32.0	6.39	35.9	7.45	39.8	8.60
35	20.2	3.92	24.1	4.79	28.0	5.74	30.0	6.25	32.0	6.79	35.9	7.93	39.8	9.16	
37	20.2	4.15	24.1	5.06	28.0	6.08	30.0	6.63	32.0	7.20	35.9	8.43	39.8	9.74	
39	20.2	4.37	24.1	5.36	28.0	6.44	30.0	7.03	32.0	7.65	35.9	8.95	39.8	10.37	
41	20.2	4.51	24.1	5.59	28.0	6.68	30.0	7.31	32.0	7.93	35.9	9.37	39.8	10.83	
43	20.2	4.65	24.1	5.82	28.0	6.91	30.0	7.53	32.0	8.21	35.9	9.77	39.8	11.30	
45	20.2	4.87	24.1	6.12	28.0	7.19	30.0	7.81	32.0	8.62	35.9	10.21	39.8	11.93	
48	20.2	5.05	24.1	6.39	28.0	7.44	30.0	8.02	32.0	8.95	35.9	10.58	39.8	12.49	

Abbreviations:

CR: Combination ratio

TC: Total capacity (kW)

PI: Power input (compressor + outdoor fan motor) (kW)

Notes:

1. Shaded cells indicate rating condition.

Table continued on next page ...



Table 2-8.6: VMEX016Q8A-D29V500 cooling capacity (continued)

CR	Outdoor air temp. (°C DB)	Indoor air temp. (°C DB / °C WB)													
		20.8 / 14.0		23.3 / 16.0		25.8 / 18.0		27.0 / 19.0		28.2 / 20.0		30.7 / 22.0		32.0 / 24.0	
		TC	PI	TC	PI	TC	PI	TC	PI	TC	PI	TC	PI	TC	PI
		kW	kW	kW	kW	kW	kW	kW	kW	kW	kW	kW	kW	kW	kW
50%	-5	16.9	2.07	20.2	2.40	23.4	2.76	25.0	2.89	26.6	3.04	29.8	3.46	33.2	3.73
	-2	16.9	2.09	20.2	2.45	23.4	2.79	25.0	2.93	26.6	3.10	29.8	3.51	33.2	3.78
	0	16.9	2.12	20.2	2.49	23.4	2.84	25.0	2.97	26.6	3.13	29.8	3.57	33.2	3.85
	2	16.9	2.15	20.2	2.52	23.4	2.89	25.0	3.01	26.6	3.19	29.8	3.58	33.2	3.92
	4	16.9	2.18	20.2	2.56	23.4	2.92	25.0	3.04	26.6	3.25	29.8	3.67	33.2	4.02
	6	16.9	2.22	20.2	2.60	23.4	2.96	25.0	3.11	26.6	3.31	29.8	3.73	33.2	4.14
	8	16.9	2.27	20.2	2.65	23.4	3.01	25.0	3.18	26.6	3.36	29.8	3.79	33.2	4.27
	10	16.9	2.32	20.2	2.68	23.4	3.06	25.0	3.23	26.6	3.45	29.8	3.89	33.2	4.34
	12	16.9	2.33	20.2	2.71	23.4	3.11	25.0	3.30	26.6	3.52	29.8	3.96	33.2	4.41
	14	16.9	2.37	20.2	2.75	23.4	3.14	25.0	3.37	26.6	3.58	29.8	4.03	33.2	4.49
	16	16.9	2.40	20.2	2.78	23.4	3.20	25.0	3.42	26.6	3.63	29.8	4.09	33.2	4.56
	18	16.9	2.44	20.2	2.83	23.4	3.25	25.0	3.47	26.6	3.70	29.8	4.16	33.2	4.65
	20	16.9	2.47	20.2	2.87	23.4	3.30	25.0	3.52	26.6	3.77	29.8	4.23	33.2	4.73
	21	16.9	2.49	20.2	2.90	23.4	3.33	25.0	3.56	26.6	3.80	29.8	4.28	33.2	4.79
	23	16.9	2.52	20.2	2.94	23.4	3.39	25.0	3.63	26.6	3.87	29.8	4.35	33.2	4.89
	25	16.9	2.56	20.2	2.99	23.4	3.45	25.0	3.70	26.6	3.99	29.8	4.58	33.2	5.22
	27	16.9	2.61	20.2	3.11	23.4	3.65	25.0	3.94	26.6	4.23	29.8	4.87	33.2	5.56
	29	16.9	2.75	20.2	3.28	23.4	3.87	25.0	4.18	26.6	4.51	29.8	5.18	33.2	5.93
	31	16.9	2.90	20.2	3.47	23.4	4.09	25.0	4.44	26.6	4.79	29.8	5.51	33.2	6.31
	33	16.9	3.08	20.2	3.68	23.4	4.35	25.0	4.70	26.6	5.08	29.8	5.86	33.2	6.70
35	16.9	3.25	20.2	3.89	23.4	4.60	25.0	4.98	26.6	5.37	29.8	6.22	33.2	7.12	
37	16.9	3.42	20.2	4.11	23.4	4.87	25.0	5.27	26.6	5.70	29.8	6.60	33.2	7.57	
39	16.9	3.61	20.2	4.34	23.4	5.15	25.0	5.58	26.6	6.05	29.8	7.00	33.2	8.03	
41	16.9	3.76	20.2	4.52	23.4	5.33	25.0	5.84	26.6	6.31	29.8	7.37	33.2	8.41	
43	16.9	4.01	20.2	4.83	23.4	5.52	25.0	6.10	26.6	6.47	29.8	7.74	33.2	8.78	
45	16.9	4.10	20.2	4.96	23.4	5.89	25.0	6.58	26.6	6.74	29.8	8.49	33.2	9.53	
48	16.9	4.20	20.2	5.10	23.4	6.24	25.0	6.99	26.6	7.04	29.8	9.17	33.2	10.25	

Abbreviations:

CR: Combination ratio

TC: Total capacity (kW)

PI: Power input (compressor + outdoor fan motor) (kW)

Notes:

1. Shaded cells indicate rating condition.

# VMEX 460V 60Hz

Table 2-8.7: VMEX018Q8A-D33V560 cooling capacity

CR	Outdoor air temp. (°C DB)	Indoor air temp. (°C DB / °C WB)													
		20.8 / 14.0		23.3 / 16.0		25.8 / 18.0		27.0 / 19.0		28.2 / 20.0		30.7 / 22.0		32.0 / 24.0	
		TC	PI	TC	PI	TC	PI	TC	PI	TC	PI	TC	PI	TC	PI
		kW	kW	kW	kW	kW	kW	kW	kW	kW	kW	kW	kW	kW	kW
130%	-5	49.2	5.93	58.6	7.24	68.0	7.76	70.6	8.08	74.0	8.31	75.8	9.03	77.7	9.09
	-2	49.2	5.93	58.6	7.38	68.0	7.76	70.6	8.12	74.0	8.31	75.8	9.15	77.7	9.18
	0	49.2	6.03	58.6	7.51	68.0	8.04	70.6	8.57	74.0	8.79	75.8	9.26	77.7	9.30
	2	49.2	6.14	58.6	7.52	68.0	8.32	70.6	9.05	74.0	8.89	75.8	9.33	77.7	9.44
	4	49.2	6.28	58.6	7.67	68.0	8.61	70.6	9.09	74.0	9.00	75.8	9.47	77.7	9.62
	6	49.2	6.40	58.6	7.82	68.0	8.93	70.6	9.17	73.2	9.28	74.9	9.61	76.9	9.69
	8	49.2	6.55	58.6	8.00	68.0	9.37	70.6	9.61	72.3	9.59	74.1	9.64	75.9	9.78
	10	49.2	6.69	58.6	8.18	68.0	9.72	70.6	9.94	71.4	9.77	73.2	9.79	75.0	10.07
	12	49.2	6.81	58.6	8.33	68.0	9.91	69.6	10.08	70.6	9.91	72.2	9.94	74.0	10.13
	14	49.2	6.94	58.6	8.49	67.8	10.06	68.8	10.23	69.6	10.06	71.4	10.09	73.2	10.36
	16	49.2	7.06	58.6	8.66	67.0	10.21	67.8	10.36	68.6	10.36	70.4	10.24	72.2	10.52
	18	49.2	7.20	58.6	8.84	66.0	10.36	66.8	10.42	67.8	10.48	69.6	10.58	71.4	10.68
	20	49.2	7.35	58.6	9.41	65.0	10.87	66.0	10.93	66.8	10.99	68.6	11.09	70.4	11.21
	21	49.2	7.55	58.6	9.74	64.6	11.13	65.6	11.19	66.4	11.25	68.2	11.36	70.0	11.46
	23	49.2	8.10	58.6	10.44	63.8	11.64	64.6	11.69	65.4	11.75	67.2	11.87	69.0	11.99
	25	49.2	8.64	58.6	11.19	62.8	12.14	63.6	12.20	64.6	12.28	66.4	12.40	68.2	12.52
	27	49.2	9.23	58.6	11.97	62.0	12.65	62.8	12.73	63.6	12.79	65.4	12.93	67.2	13.06
	29	49.2	9.86	58.6	12.79	61.0	13.16	61.8	13.24	62.8	13.32	64.6	13.46	66.4	13.59
	31	49.2	10.52	58.4	13.53	60.0	13.69	61.0	13.77	61.8	13.83	63.6	13.98	65.4	14.14
	33	49.2	11.21	57.4	14.04	59.2	14.20	60.0	14.28	61.0	14.35	62.8	14.51	64.4	14.67
35	49.2	11.95	56.4	14.55	58.2	14.73	59.2	14.80	60.0	14.88	61.8	15.06	63.6	15.21	
37	49.2	12.71	55.6	15.08	57.4	15.25	58.2	15.33	59.2	15.43	60.8	15.61	62.6	15.78	
39	49.2	13.53	54.6	15.24	56.4	15.76	57.4	15.86	58.2	15.96	60.0	16.13	61.8	16.33	
41	49.2	14.24	54.0	15.38	55.8	15.91	56.8	16.01	57.6	16.11	59.4	16.17	59.4	16.48	
43	49.2	14.61	53.6	15.46	55.5	15.95	56.5	16.08	57.0	16.13	58.3	16.20	58.7	16.51	
45	49.2	15.33	53.3	15.61	54.9	16.10	55.9	16.19	56.2	16.20	56.7	16.26	57.6	16.83	
48	49.2	15.88	53.1	16.11	54.0	16.25	55.0	16.33	55.5	16.39	55.2	16.53	56.2	16.88	
120%	-5	45.4	5.73	54.0	6.94	62.8	8.21	67.2	8.95	70.4	9.33	72.0	9.63	73.6	9.88
	-2	45.4	5.79	54.0	7.01	62.8	8.29	67.2	9.00	70.4	9.44	72.0	9.71	73.6	9.92
	0	45.4	5.84	54.0	7.06	62.8	8.38	67.2	9.02	70.4	9.52	72.0	9.76	73.6	9.94
	2	45.4	5.85	54.0	7.13	62.8	8.44	67.2	9.11	70.4	9.56	72.0	9.84	73.6	9.96
	4	45.4	5.91	54.0	7.22	62.8	8.56	67.2	9.19	70.4	9.69	72.0	9.86	73.6	9.98
	6	45.4	5.98	54.0	7.28	62.8	8.66	67.2	9.29	70.4	9.79	72.0	9.94	73.6	10.01
	8	45.4	6.03	54.0	7.35	62.8	8.78	67.2	9.41	70.4	9.89	72.0	9.97	73.6	10.06
	10	45.4	6.10	54.0	7.45	62.8	8.86	67.2	9.58	70.4	9.90	72.0	10.00	73.6	10.11
	12	45.4	6.22	54.0	7.59	62.8	9.03	67.2	9.76	69.4	9.94	71.0	9.94	72.6	10.17
	14	45.4	6.34	54.0	7.74	62.8	9.21	67.2	9.95	68.4	10.00	70.2	10.10	71.8	10.29
	16	45.4	6.45	54.0	7.90	62.8	9.39	66.8	10.13	67.6	10.15	69.2	10.26	70.8	10.45
	18	45.4	6.57	54.0	8.06	62.8	9.70	65.8	10.36	66.6	10.40	68.2	10.50	70.0	10.60
	20	45.4	6.71	54.0	8.37	62.8	10.44	65.0	10.87	65.8	10.91	67.4	11.01	69.0	11.11
	21	45.4	6.77	54.0	8.66	62.8	10.81	64.4	11.13	65.2	11.17	67.0	11.26	68.6	11.38
	23	45.4	7.24	54.0	9.29	62.8	11.58	63.6	11.62	64.4	11.68	66.0	11.79	67.6	11.89
	25	45.4	7.73	54.0	9.93	61.8	12.09	62.6	12.13	63.4	12.18	65.2	12.30	66.8	12.42
	27	45.4	8.25	54.0	10.62	61.0	12.58	61.8	12.65	62.6	12.71	64.2	12.83	65.8	12.95
	29	45.4	8.80	54.0	11.34	60.0	13.08	60.8	13.16	61.6	13.22	63.2	13.36	65.0	13.47
	31	45.4	9.39	54.0	12.10	59.0	13.61	60.0	13.67	60.8	13.75	62.4	13.88	64.0	14.02
	33	45.4	9.99	54.0	12.91	58.2	14.12	59.0	14.20	59.8	14.26	61.4	14.41	63.0	14.55
35	45.4	10.64	54.0	13.77	57.2	14.63	58.0	14.71	59.0	14.78	60.6	14.94	62.2	15.10	
37	45.4	11.32	54.0	14.67	56.4	15.16	57.2	15.23	58.0	15.31	59.6	15.47	61.2	15.64	
39	45.4	12.05	53.8	15.49	55.4	15.66	56.2	15.76	57.0	15.84	58.8	16.02	60.4	16.17	
41	45.4	12.38	53.4	15.60	55.0	15.78	55.8	15.87	56.6	15.95	58.4	16.06	58.7	16.29	
43	45.4	12.56	53.1	15.71	54.5	15.87	55.3	15.93	56.1	16.01	57.3	16.10	57.8	16.62	
45	45.4	12.71	52.8	15.86	54.0	16.02	54.8	16.08	55.6	16.13	56.2	16.15	57.2	16.98	
48	45.4	12.81	52.3	16.03	53.3	16.16	53.9	16.20	55.0	16.26	55.3	16.21	56.4	17.20	

Abbreviations:

CR: Combination ratio

TC: Total capacity (kW)

PI: Power input (compressor + outdoor fan motor) (kW)

Notes:

1. Shaded cells indicate rating condition.

Table continued on next page ...

Table 2-8.7: VMEX018Q8A-D33V560 cooling capacity (continued)

CR	Outdoor air temp. (°C DB)	Indoor air temp. (°C DB / °C WB)													
		20.8 / 14.0		23.3 / 16.0		25.8 / 18.0		27.0 / 19.0		28.2 / 20.0		30.7 / 22.0		32.0 / 24.0	
		TC	PI	TC	PI	TC	PI	TC	PI	TC	PI	TC	PI	TC	PI
		kW	kW	kW	kW	kW	kW	kW	kW	kW	kW	kW	kW	kW	kW
110%	-5	41.6	5.00	49.6	6.23	57.6	7.43	61.6	7.98	65.6	8.58	70.6	8.91	72.2	9.19
	-2	41.6	5.10	49.6	6.31	57.6	7.49	61.6	8.06	65.6	8.65	70.6	9.00	72.2	9.24
	0	41.6	5.15	49.6	6.34	57.6	7.55	61.6	8.11	65.6	8.75	70.6	9.09	72.2	9.35
	2	41.6	5.26	49.6	6.40	57.6	7.67	61.6	8.20	65.6	8.84	70.6	9.22	72.2	9.47
	4	41.6	5.37	49.6	6.48	57.6	7.74	61.6	8.30	65.6	8.97	70.6	9.35	72.2	9.55
	6	41.6	5.42	49.6	6.55	57.6	7.82	61.6	8.43	65.6	9.07	70.6	9.45	72.2	9.70
	8	41.6	5.47	49.6	6.66	57.6	7.91	61.6	8.52	65.6	9.18	70.6	9.51	72.2	9.80
	10	41.6	5.53	49.6	6.75	57.6	8.02	61.6	8.66	65.6	9.33	70.6	9.58	72.2	9.89
	12	41.6	5.65	49.6	6.88	57.6	8.18	61.6	8.84	65.6	9.50	69.8	9.72	71.2	10.02
	14	41.6	5.75	49.6	7.00	57.6	8.33	61.6	9.00	65.6	9.68	68.8	9.80	70.4	10.09
	16	41.6	5.85	49.6	7.14	57.6	8.49	61.6	9.17	65.6	9.88	68.0	9.91	69.4	10.20
	18	41.6	5.96	49.6	7.28	57.6	8.66	61.6	9.43	65.6	10.35	67.0	10.42	68.6	10.52
	20	41.6	6.08	49.6	7.43	57.6	9.17	61.6	10.13	64.6	10.85	66.2	10.93	67.6	11.03
	21	41.6	6.14	49.6	7.65	57.6	9.50	61.6	10.50	64.2	11.11	65.6	11.19	67.2	11.28
	23	41.6	6.43	49.6	8.19	57.6	10.19	61.6	11.26	63.2	11.60	64.8	11.71	66.2	11.81
	25	41.6	6.86	49.6	8.76	57.6	10.89	61.6	12.07	62.4	12.10	63.8	12.22	65.4	12.32
	27	41.6	7.31	49.6	9.37	57.6	11.66	60.6	12.58	61.4	12.61	63.0	12.73	64.4	12.85
	29	41.6	7.80	49.6	9.99	57.6	12.46	59.8	13.08	60.6	13.14	62.0	13.26	63.6	13.38
	31	41.6	8.31	49.6	10.66	57.6	13.30	58.8	13.59	59.6	13.65	61.2	13.77	62.6	13.90
	33	41.6	8.84	49.6	11.36	57.2	14.02	58.0	14.10	58.8	14.16	60.2	14.30	61.8	14.43
35	41.6	9.41	49.6	12.10	56.2	14.53	57.0	14.61	57.8	14.69	59.2	14.82	60.8	14.96	
37	41.6	10.01	49.6	12.89	55.4	15.06	56.2	15.12	56.8	15.20	58.4	15.35	59.8	15.49	
39	41.6	10.64	49.6	13.73	54.4	15.57	55.2	15.65	56.0	15.72	57.4	15.88	59.0	16.04	
41	41.6	10.75	49.6	13.84	54.0	15.68	54.8	15.76	55.6	15.83	56.7	15.99	57.2	16.15	
43	41.6	10.86	49.6	14.02	53.5	15.79	54.3	15.87	55.1	15.94	56.2	16.05	56.3	16.47	
45	41.6	11.21	49.6	14.09	53.0	15.93	53.8	16.06	54.7	16.09	55.6	16.49	55.8	16.86	
48	41.6	11.60	49.6	15.29	52.2	16.04	52.9	16.17	54.0	16.26	54.7	16.55	55.1	17.04	
100%	-5	37.8	4.56	45.0	5.48	52.4	6.53	56.0	6.99	59.6	7.59	67.0	8.65	70.8	9.03
	-2	37.8	4.61	45.0	5.56	52.4	6.60	56.0	7.12	59.6	7.69	67.0	8.75	70.8	9.08
	0	37.8	4.66	45.0	5.62	52.4	6.67	56.0	7.21	59.6	7.76	67.0	8.89	70.8	9.18
	2	37.8	4.75	45.0	5.69	52.4	6.75	56.0	7.31	59.6	7.85	67.0	9.03	70.8	9.33
	4	37.8	4.79	45.0	5.75	52.4	6.85	56.0	7.41	59.6	7.95	67.0	9.11	70.8	9.43
	6	37.8	4.85	45.0	5.86	52.4	6.94	56.0	7.55	59.6	8.07	67.0	9.24	70.8	9.58
	8	37.8	4.95	45.0	5.95	52.4	7.06	56.0	7.63	59.6	8.20	67.0	9.39	70.8	9.74
	10	37.8	5.01	45.0	6.06	52.4	7.18	56.0	7.76	59.6	8.35	67.0	9.54	70.8	9.88
	12	37.8	5.08	45.0	6.18	52.4	7.31	56.0	7.90	59.6	8.51	67.0	9.72	69.8	9.95
	14	37.8	5.18	45.0	6.30	52.4	7.45	56.0	8.06	59.6	8.66	67.0	9.91	69.0	10.07
	16	37.8	5.28	45.0	6.41	52.4	7.61	56.0	8.21	59.6	8.84	66.6	10.03	68.0	10.19
	18	37.8	5.38	45.0	6.53	52.4	7.74	56.0	8.37	59.6	9.02	65.8	10.36	67.2	10.44
	20	37.8	5.48	45.0	6.67	52.4	7.98	56.0	8.80	59.6	9.66	64.8	10.85	66.2	10.95
	21	37.8	5.53	45.0	6.73	52.4	8.27	56.0	9.11	59.6	9.99	64.4	11.11	65.8	11.20
	23	37.8	5.67	45.0	7.18	52.4	8.86	56.0	9.76	59.6	10.72	63.6	11.62	64.8	11.71
	25	37.8	6.04	45.0	7.67	52.4	9.48	56.0	10.46	59.6	11.48	62.6	12.12	64.0	12.22
	27	37.8	6.45	45.0	8.17	52.4	10.13	56.0	11.19	59.6	12.28	61.6	12.63	63.0	12.75
	29	37.8	6.86	45.0	8.72	52.4	10.81	56.0	11.95	59.4	13.04	60.8	13.16	62.2	13.26
	31	37.8	7.31	45.0	9.31	52.4	11.54	56.0	12.75	58.6	13.55	59.8	13.67	61.2	13.79
	33	37.8	7.76	45.0	9.91	52.4	12.30	56.0	13.61	57.6	14.06	59.0	14.18	60.4	14.31
35	37.8	8.25	45.0	10.54	52.4	13.12	56.0	14.51	56.6	14.57	58.0	14.70	59.4	14.82	
37	37.8	8.78	45.0	11.22	52.4	13.98	55.0	15.02	55.8	15.10	57.2	15.23	58.4	15.35	
39	37.8	9.33	45.0	11.93	52.4	14.88	54.2	15.53	54.8	15.61	56.2	15.74	57.6	15.90	
41	37.8	9.76	45.0	12.36	52.4	15.43	53.4	15.64	54.4	15.85	55.2	16.11	56.8	16.23	
43	37.8	10.20	45.0	12.80	52.4	15.71	52.5	15.82	54.0	16.00	55.6	16.22	55.8	16.41	
45	37.8	10.78	45.0	13.38	52.4	15.98	51.4	16.04	53.7	16.29	55.1	16.47	54.6	16.62	
48	37.8	11.25	45.0	13.85	52.4	16.01	49.3	16.22	53.6	16.58	51.7	16.64	53.4	16.78	

Abbreviations:

CR: Combination ratio

TC: Total capacity (kW)

PI: Power input (compressor + outdoor fan motor) (kW)

Notes:

1. Shaded cells indicate rating condition.

Table continued on next page ...

# VMEX 460V 60Hz

Table 2-8.7: VMEX018Q8A-D33V560 cooling capacity (continued)

CR	Outdoor air temp. (°C DB)	Indoor air temp. (°C DB / °C WB)													
		20.8 / 14.0		23.3 / 16.0		25.8 / 18.0		27.0 / 19.0		28.2 / 20.0		30.7 / 22.0		32.0 / 24.0	
		TC	PI	TC	PI	TC	PI	TC	PI	TC	PI	TC	PI	TC	PI
		kW	kW	kW	kW	kW	kW	kW	kW	kW	kW	kW	kW	kW	kW
90%	-5	34.0	4.03	40.6	4.83	47.2	5.70	50.4	6.22	53.6	6.62	60.2	7.61	66.8	8.72
	-2	34.0	4.07	40.6	4.88	47.2	5.78	50.4	6.31	53.6	6.70	60.2	7.69	66.8	8.80
	0	34.0	4.13	40.6	4.95	47.2	5.86	50.4	6.38	53.6	6.79	60.2	7.77	66.8	8.87
	2	34.0	4.19	40.6	5.01	47.2	5.93	50.4	6.48	53.6	6.89	60.2	7.93	66.8	9.00
	4	34.0	4.25	40.6	5.08	47.2	6.03	50.4	6.57	53.6	6.98	60.2	8.06	66.8	9.13
	6	34.0	4.31	40.6	5.18	47.2	6.14	50.4	6.69	53.6	7.10	60.2	8.18	66.8	9.29
	8	34.0	4.39	40.6	5.28	47.2	6.26	50.4	6.78	53.6	7.23	60.2	8.33	66.8	9.37
	10	34.0	4.48	40.6	5.40	47.2	6.37	50.4	6.88	53.6	7.39	60.2	8.44	66.8	9.52
	12	34.0	4.56	40.6	5.49	47.2	6.49	50.4	7.00	53.6	7.53	60.2	8.60	66.8	9.70
	14	34.0	4.63	40.6	5.59	47.2	6.61	50.4	7.14	53.6	7.67	60.2	8.76	66.8	9.87
	16	34.0	4.71	40.6	5.69	47.2	6.75	50.4	7.27	53.6	7.82	60.2	8.94	66.6	10.05
	18	34.0	4.79	40.6	5.81	47.2	6.86	50.4	7.41	53.6	7.98	60.2	9.11	65.8	10.36
	20	34.0	4.89	40.6	5.94	47.2	7.00	50.4	7.57	53.6	8.27	60.2	9.80	64.8	10.85
	21	34.0	4.93	40.6	5.98	47.2	7.12	50.4	7.82	53.6	8.57	60.2	10.15	64.4	11.11
	23	34.0	5.03	40.6	6.22	47.2	7.63	50.4	8.39	53.6	9.19	60.2	10.89	63.4	11.62
	25	34.0	5.30	40.6	6.65	47.2	8.15	50.4	8.98	53.6	9.82	60.2	11.65	62.6	12.12
	27	34.0	5.63	40.6	7.08	47.2	8.70	50.4	9.58	53.6	10.50	60.2	12.48	61.6	12.63
	29	34.0	6.00	40.6	7.55	47.2	9.29	50.4	10.23	53.6	11.22	59.6	13.04	60.8	13.14
	31	34.0	6.37	40.6	8.04	47.2	9.89	50.4	10.91	53.6	11.97	58.6	13.55	59.8	13.67
	33	34.0	6.77	40.6	8.55	47.2	10.56	50.4	11.63	53.6	12.77	57.8	14.08	59.0	14.18
35	34.0	7.20	40.6	9.09	47.2	11.24	50.4	12.40	53.6	13.61	56.8	14.59	58.0	14.70	
37	34.0	7.63	40.6	9.66	47.2	11.97	50.4	13.20	53.6	14.51	55.8	15.10	57.2	15.21	
39	34.0	8.10	40.6	10.29	47.2	12.73	50.4	14.06	53.6	15.45	55.0	15.62	56.2	15.74	
41	34.0	8.37	40.6	10.75	47.2	13.19	50.4	14.43	53.6	15.54	54.6	16.02	55.8	16.11	
43	34.0	8.78	40.6	11.22	47.2	13.66	50.4	14.80	53.6	15.87	54.3	16.23	55.3	16.36	
45	34.0	9.34	40.6	11.77	47.2	14.22	50.4	15.30	53.6	16.31	54.0	16.40	54.5	16.58	
48	34.0	9.85	40.6	12.32	47.2	14.75	50.4	15.49	53.6	16.45	53.6	16.63	53.0	16.81	
80%	-5	30.2	3.55	36.0	4.20	41.8	4.97	44.8	5.28	47.8	5.69	53.6	6.58	59.4	7.51
	-2	30.2	3.60	36.0	4.25	41.8	5.01	44.8	5.37	47.8	5.74	53.6	6.64	59.4	7.58
	0	30.2	3.67	36.0	4.30	41.8	5.08	44.8	5.43	47.8	5.85	53.6	6.74	59.4	7.69
	2	30.2	3.74	36.0	4.37	41.8	5.15	44.8	5.53	47.8	5.95	53.6	6.87	59.4	7.83
	4	30.2	3.80	36.0	4.44	41.8	5.25	44.8	5.66	47.8	6.06	53.6	7.00	59.4	7.94
	6	30.2	3.86	36.0	4.54	41.8	5.33	44.8	5.79	47.8	6.17	53.6	7.10	59.4	8.07
	8	30.2	3.94	36.0	4.65	41.8	5.45	44.8	5.88	47.8	6.31	53.6	7.21	59.4	8.23
	10	30.2	3.97	36.0	4.75	41.8	5.59	44.8	6.02	47.8	6.45	53.6	7.37	59.4	8.31
	12	30.2	4.03	36.0	4.83	41.8	5.69	44.8	6.14	47.8	6.59	53.6	7.51	59.4	8.47
	14	30.2	4.11	36.0	4.93	41.8	5.79	44.8	6.24	47.8	6.71	53.6	7.65	59.4	8.62
	16	30.2	4.17	36.0	5.01	41.8	5.91	44.8	6.36	47.8	6.83	53.6	7.80	59.4	8.78
	18	30.2	4.24	36.0	5.10	41.8	6.02	44.8	6.49	47.8	6.96	53.6	7.96	59.4	8.96
	20	30.2	4.32	36.0	5.20	41.8	6.14	44.8	6.61	47.8	7.10	53.6	8.25	59.4	9.58
	21	30.2	4.36	36.0	5.24	41.8	6.20	44.8	6.69	47.8	7.26	53.6	8.55	59.4	9.93
	23	30.2	4.44	36.0	5.36	41.8	6.49	44.8	7.12	47.8	7.76	53.6	9.15	59.4	10.66
	25	30.2	4.58	36.0	5.69	41.8	6.94	44.8	7.61	47.8	8.29	53.6	9.80	59.4	11.40
	27	30.2	4.87	36.0	6.06	41.8	7.39	44.8	8.12	47.8	8.86	53.6	10.46	59.4	12.20
	29	30.2	5.18	36.0	6.45	41.8	7.88	44.8	8.64	47.8	9.47	53.6	11.17	59.4	13.04
	31	30.2	5.50	36.0	6.86	41.8	8.39	44.8	9.21	47.8	10.09	53.6	11.93	58.4	13.55
	33	30.2	5.85	36.0	7.29	41.8	8.94	44.8	9.82	47.8	10.74	53.6	12.71	57.6	14.06
35	30.2	6.20	36.0	7.76	41.8	9.50	44.8	10.44	47.8	11.44	53.6	13.55	56.6	14.57	
37	30.2	6.57	36.0	8.23	41.8	10.11	44.8	11.13	47.8	12.18	53.6	14.45	55.8	15.08	
39	30.2	6.96	36.0	8.78	41.8	10.76	44.8	11.83	47.8	12.97	53.6	15.39	54.8	15.61	
41	30.2	7.12	36.0	8.86	41.8	10.91	44.8	12.15	47.8	13.20	53.6	15.78	54.5	15.88	
43	30.2	7.33	36.0	8.94	41.8	11.07	44.8	12.35	47.8	13.38	53.6	15.97	54.1	16.05	
45	30.2	7.54	36.0	9.04	41.8	11.28	44.8	12.61	47.8	13.62	53.6	16.14	53.5	16.31	
48	30.2	7.78	36.0	9.10	41.8	11.46	44.8	12.79	47.8	13.73	53.6	16.30	53.0	16.54	

Abbreviations:

CR: Combination ratio

TC: Total capacity (kW)

PI: Power input (compressor + outdoor fan motor) (kW)

Notes:

1. Shaded cells indicate rating condition.

Table continued on next page ...

Table 2-8.7: VMEX018Q8A-D33V560 cooling capacity (continued)

CR	Outdoor air temp. (°C DB)	Indoor air temp. (°C DB / °C WB)													
		20.8 / 14.0		23.3 / 16.0		25.8 / 18.0		27.0 / 19.0		28.2 / 20.0		30.7 / 22.0		32.0 / 24.0	
		TC	PI	TC	PI	TC	PI	TC	PI	TC	PI	TC	PI	TC	PI
		kW	kW	kW	kW	kW	kW	kW	kW	kW	kW	kW	kW	kW	kW
70%	-5	26.4	3.17	31.6	3.72	36.6	4.21	39.2	4.52	41.8	4.82	46.8	5.51	52.0	6.34
	-2	26.4	3.20	31.6	3.73	36.6	4.24	39.2	4.60	41.8	4.91	46.8	5.60	52.0	6.43
	0	26.4	3.21	31.6	3.79	36.6	4.32	39.2	4.69	41.8	4.99	46.8	5.71	52.0	6.51
	2	26.4	3.23	31.6	3.80	36.6	4.39	39.2	4.78	41.8	5.08	46.8	5.83	52.0	6.62
	4	26.4	3.27	31.6	3.90	36.6	4.49	39.2	4.86	41.8	5.19	46.8	5.93	52.0	6.77
	6	26.4	3.33	31.6	3.97	36.6	4.60	39.2	5.02	41.8	5.31	46.8	6.03	52.0	6.90
	8	26.4	3.39	31.6	4.08	36.6	4.71	39.2	5.10	41.8	5.43	46.8	6.21	52.0	7.03
	10	26.4	3.46	31.6	4.15	36.6	4.83	39.2	5.20	41.8	5.57	46.8	6.34	52.0	7.12
	12	26.4	3.54	31.6	4.20	36.6	4.93	39.2	5.30	41.8	5.67	46.8	6.45	52.0	7.26
	14	26.4	3.60	31.6	4.28	36.6	5.01	39.2	5.38	41.8	5.77	46.8	6.57	52.0	7.39
	16	26.4	3.66	31.6	4.36	36.6	5.10	39.2	5.50	41.8	5.89	46.8	6.69	52.0	7.53
	18	26.4	3.72	31.6	4.44	36.6	5.20	39.2	5.59	41.8	5.98	46.8	6.82	52.0	7.69
	20	26.4	3.77	31.6	4.52	36.6	5.30	39.2	5.69	41.8	6.10	46.8	6.96	52.0	7.90
	21	26.4	3.81	31.6	4.56	36.6	5.34	39.2	5.75	41.8	6.16	46.8	7.06	52.0	8.17
	23	26.4	3.87	31.6	4.63	36.6	5.46	39.2	5.95	41.8	6.47	46.8	7.57	52.0	8.76
	25	26.4	3.95	31.6	4.83	36.6	5.81	39.2	6.36	41.8	6.90	46.8	8.10	52.0	9.37
	27	26.4	4.19	31.6	5.14	36.6	6.20	39.2	6.77	41.8	7.37	46.8	8.64	52.0	10.01
	29	26.4	4.44	31.6	5.46	36.6	6.59	39.2	7.22	41.8	7.84	46.8	9.21	52.0	10.70
	31	26.4	4.69	31.6	5.79	36.6	7.02	39.2	7.67	41.8	8.35	46.8	9.82	52.0	11.40
	33	26.4	4.99	31.6	6.16	36.6	7.47	39.2	8.15	41.8	8.90	46.8	10.46	52.0	12.16
35	26.4	5.28	31.6	6.53	36.6	7.92	39.2	8.68	41.8	9.47	46.8	11.15	52.0	12.97	
37	26.4	5.57	31.6	6.92	36.6	8.43	39.2	9.21	41.8	10.07	46.8	11.87	52.0	13.81	
39	26.4	5.91	31.6	7.33	36.6	8.94	39.2	9.80	41.8	10.70	46.8	12.61	52.0	14.71	
41	26.4	6.17	31.6	7.59	36.6	9.20	39.2	10.12	41.8	11.02	46.8	13.13	52.0	15.36	
43	26.4	6.67	31.6	8.11	36.6	9.58	39.2	10.67	41.8	11.35	46.8	13.61	52.0	15.83	
45	26.4	6.82	31.6	8.29	36.6	9.78	39.2	10.84	41.8	11.91	46.8	14.35	52.0	16.44	
48	26.4	6.99	31.6	8.36	36.6	9.88	39.2	11.02	41.8	12.24	46.8	14.99	52.0	16.83	
60%	-5	22.6	2.70	27.0	3.14	31.4	3.65	33.6	3.89	35.8	4.20	40.2	4.72	44.6	5.41
	-2	22.6	2.72	27.0	3.19	31.4	3.72	33.6	3.95	35.8	4.25	40.2	4.79	44.6	5.45
	0	22.6	2.76	27.0	3.22	31.4	3.77	33.6	4.00	35.8	4.32	40.2	4.86	44.6	5.52
	2	22.6	2.81	27.0	3.30	31.4	3.84	33.6	4.08	35.8	4.38	40.2	4.96	44.6	5.59
	4	22.6	2.89	27.0	3.36	31.4	3.91	33.6	4.13	35.8	4.44	40.2	5.04	44.6	5.67
	6	22.6	2.92	27.0	3.43	31.4	3.99	33.6	4.22	35.8	4.53	40.2	5.14	44.6	5.80
	8	22.6	2.97	27.0	3.48	31.4	4.06	33.6	4.30	35.8	4.62	40.2	5.24	44.6	5.90
	10	22.6	3.03	27.0	3.56	31.4	4.13	33.6	4.42	35.8	4.71	40.2	5.34	44.6	5.98
	12	22.6	3.09	27.0	3.62	31.4	4.20	33.6	4.50	35.8	4.79	40.2	5.44	44.6	6.08
	14	22.6	3.13	27.0	3.68	31.4	4.26	33.6	4.58	35.8	4.89	40.2	5.53	44.6	6.20
	16	22.6	3.17	27.0	3.73	31.4	4.34	33.6	4.65	35.8	4.97	40.2	5.63	44.6	6.32
	18	22.6	3.23	27.0	3.79	31.4	4.42	33.6	4.73	35.8	5.06	40.2	5.73	44.6	6.43
	20	22.6	3.27	27.0	3.87	31.4	4.50	33.6	4.83	35.8	5.16	40.2	5.85	44.6	6.57
	21	22.6	3.30	27.0	3.89	31.4	4.54	33.6	4.87	35.8	5.20	40.2	5.91	44.6	6.63
	23	22.6	3.34	27.0	3.97	31.4	4.61	33.6	4.97	35.8	5.30	40.2	6.14	44.6	7.06
	25	22.6	3.40	27.0	4.03	31.4	4.79	33.6	5.20	35.8	5.63	40.2	6.55	44.6	7.53
	27	22.6	3.54	27.0	4.28	31.4	5.10	33.6	5.55	35.8	6.00	40.2	6.98	44.6	8.04
	29	22.6	3.73	27.0	4.54	31.4	5.44	33.6	5.91	35.8	6.39	40.2	7.45	44.6	8.58
	31	22.6	3.97	27.0	4.81	31.4	5.77	33.6	6.28	35.8	6.80	40.2	7.92	44.6	9.13
	33	22.6	4.18	27.0	5.10	31.4	6.12	33.6	6.67	35.8	7.23	40.2	8.43	44.6	9.74
35	22.6	4.44	27.0	5.42	31.4	6.49	33.6	7.08	35.8	7.68	40.2	8.97	44.6	10.36	
37	22.6	4.69	27.0	5.73	31.4	6.88	33.6	7.51	35.8	8.15	40.2	9.54	44.6	11.03	
39	22.6	4.95	27.0	6.06	31.4	7.29	33.6	7.96	35.8	8.66	40.2	10.13	44.6	11.73	
41	22.6	5.11	27.0	6.32	31.4	7.56	33.6	8.28	35.8	8.98	40.2	10.61	44.6	12.26	
43	22.6	5.27	27.0	6.59	31.4	7.82	33.6	8.52	35.8	9.29	40.2	11.06	44.6	12.79	
45	22.6	5.51	27.0	6.92	31.4	8.14	33.6	8.84	35.8	9.75	40.2	11.55	44.6	13.50	
48	22.6	5.72	27.0	7.23	31.4	8.42	33.6	9.07	35.8	10.13	40.2	11.97	44.6	14.14	

Abbreviations:

CR: Combination ratio

TC: Total capacity (kW)

PI: Power input (compressor + outdoor fan motor) (kW)

Notes:

1. Shaded cells indicate rating condition.

Table continued on next page ...

# VMEX 460V 60Hz

Table 2-8.7: VMEX018Q8A-D33V560 cooling capacity (continued)

CR	Outdoor air temp. (°C DB)	Indoor air temp. (°C DB / °C WB)													
		20.8 / 14.0		23.3 / 16.0		25.8 / 18.0		27.0 / 19.0		28.2 / 20.0		30.7 / 22.0		32.0 / 24.0	
		TC	PI	TC	PI	TC	PI	TC	PI	TC	PI	TC	PI	TC	PI
		kW	kW	kW	kW	kW	kW	kW	kW	kW	kW	kW	kW	kW	kW
50%	-5	18.9	2.35	22.6	2.72	26.2	3.12	28.0	3.27	29.8	3.45	33.4	3.92	37.2	4.22
	-2	18.9	2.37	22.6	2.77	26.2	3.15	28.0	3.31	29.8	3.51	33.4	3.97	37.2	4.28
	0	18.9	2.40	22.6	2.82	26.2	3.21	28.0	3.36	29.8	3.55	33.4	4.04	37.2	4.35
	2	18.9	2.44	22.6	2.85	26.2	3.27	28.0	3.41	29.8	3.61	33.4	4.05	37.2	4.44
	4	18.9	2.46	22.6	2.90	26.2	3.30	28.0	3.45	29.8	3.68	33.4	4.16	37.2	4.55
	6	18.9	2.51	22.6	2.95	26.2	3.35	28.0	3.53	29.8	3.75	33.4	4.22	37.2	4.69
	8	18.9	2.57	22.6	3.00	26.2	3.41	28.0	3.60	29.8	3.80	33.4	4.29	37.2	4.84
	10	18.9	2.62	22.6	3.03	26.2	3.46	28.0	3.66	29.8	3.91	33.4	4.40	37.2	4.91
	12	18.9	2.64	22.6	3.07	26.2	3.52	28.0	3.73	29.8	3.99	33.4	4.48	37.2	4.99
	14	18.9	2.68	22.6	3.11	26.2	3.56	28.0	3.81	29.8	4.05	33.4	4.56	37.2	5.08
	16	18.9	2.72	22.6	3.15	26.2	3.62	28.0	3.87	29.8	4.11	33.4	4.63	37.2	5.16
	18	18.9	2.76	22.6	3.21	26.2	3.68	28.0	3.93	29.8	4.18	33.4	4.71	37.2	5.26
	20	18.9	2.80	22.6	3.25	26.2	3.73	28.0	3.99	29.8	4.26	33.4	4.79	37.2	5.36
	21	18.9	2.82	22.6	3.28	26.2	3.77	28.0	4.03	29.8	4.30	33.4	4.85	37.2	5.42
	23	18.9	2.85	22.6	3.32	26.2	3.83	28.0	4.11	29.8	4.38	33.4	4.93	37.2	5.53
	25	18.9	2.89	22.6	3.38	26.2	3.91	28.0	4.18	29.8	4.52	33.4	5.18	37.2	5.91
	27	18.9	2.95	22.6	3.52	26.2	4.13	28.0	4.46	29.8	4.79	33.4	5.51	37.2	6.30
	29	18.9	3.11	22.6	3.71	26.2	4.38	28.0	4.73	29.8	5.10	33.4	5.87	37.2	6.71
	31	18.9	3.28	22.6	3.93	26.2	4.63	28.0	5.03	29.8	5.42	33.4	6.24	37.2	7.14
	33	18.9	3.48	22.6	4.16	26.2	4.93	28.0	5.32	29.8	5.75	33.4	6.63	37.2	7.59
35	18.9	3.68	22.6	4.40	26.2	5.20	28.0	5.63	29.8	6.08	33.4	7.04	37.2	8.06	
37	18.9	3.87	22.6	4.65	26.2	5.51	28.0	5.96	29.8	6.45	33.4	7.47	37.2	8.56	
39	18.9	4.09	22.6	4.91	26.2	5.83	28.0	6.32	29.8	6.84	33.4	7.92	37.2	9.09	
41	18.9	4.26	22.6	5.12	26.2	6.04	28.0	6.61	29.8	7.14	33.4	8.34	37.2	9.51	
43	18.9	4.54	22.6	5.47	26.2	6.25	28.0	6.91	29.8	7.32	33.4	8.76	37.2	9.94	
45	18.9	4.64	22.6	5.61	26.2	6.67	28.0	7.44	29.8	7.63	33.4	9.61	37.2	10.78	
48	18.9	4.75	22.6	5.77	26.2	7.06	28.0	7.91	29.8	7.97	33.4	10.38	37.2	11.60	

Abbreviations:

CR: Combination ratio

TC: Total capacity (kW)

PI: Power input (compressor + outdoor fan motor) (kW)

Notes:

1. Shaded cells indicate rating condition.

Table 2-8.8: VMEX020Q8A-D36V615 cooling capacity

CR	Outdoor air temp. (°C DB)	Indoor air temp. (°C DB / °C WB)													
		20.8 / 14.0		23.3 / 16.0		25.8 / 18.0		27.0 / 19.0		28.2 / 20.0		30.7 / 22.0		32.0 / 24.0	
		TC	PI	TC	PI	TC	PI	TC	PI	TC	PI	TC	PI	TC	PI
		kW	kW	kW	kW	kW	kW	kW	kW	kW	kW	kW	kW	kW	kW
130%	-5	54.0	6.72	64.4	8.20	74.7	8.79	77.5	9.15	81.3	9.41	83.2	10.23	85.3	10.30
	-2	54.0	6.72	64.4	8.36	74.7	8.79	77.5	9.20	81.3	9.41	83.2	10.36	85.3	10.40
	0	54.0	6.84	64.4	8.51	74.7	9.11	77.5	9.71	81.3	9.96	83.2	10.49	85.3	10.54
	2	54.0	6.96	64.4	8.52	74.7	9.43	77.5	10.26	81.3	10.07	83.2	10.57	85.3	10.69
	4	54.0	7.11	64.4	8.69	74.7	9.75	77.5	10.30	81.3	10.20	83.2	10.73	85.3	10.90
	6	54.0	7.25	64.4	8.86	74.7	10.11	77.5	10.38	80.4	10.52	82.2	10.89	84.4	10.98
	8	54.0	7.42	64.4	9.07	74.7	10.62	77.5	10.89	79.4	10.86	81.3	10.93	83.3	11.09
	10	54.0	7.58	64.4	9.26	74.7	11.01	77.5	11.26	78.4	11.06	80.4	11.09	82.4	11.41
	12	54.0	7.71	64.4	9.44	74.7	11.23	76.4	11.42	77.5	11.23	79.3	11.26	81.3	11.48
	14	54.0	7.87	64.4	9.62	74.5	11.40	75.6	11.59	76.4	11.40	78.4	11.43	80.4	11.74
	16	54.0	8.00	64.4	9.82	73.6	11.57	74.5	11.74	75.3	11.73	77.3	11.60	79.3	11.92
	18	54.0	8.15	64.4	10.02	72.5	11.74	73.4	11.81	74.5	11.88	76.4	11.99	78.4	12.10
	20	54.0	8.33	64.4	10.66	71.4	12.32	72.5	12.39	73.4	12.45	75.3	12.56	77.3	12.70
	21	54.0	8.55	64.4	11.04	70.9	12.61	72.0	12.67	72.9	12.74	74.9	12.87	76.9	12.98
	23	54.0	9.17	64.4	11.83	70.1	13.18	70.9	13.25	71.8	13.32	73.8	13.45	75.8	13.58
	25	54.0	9.79	64.4	12.67	69.0	13.76	69.8	13.83	70.9	13.92	72.9	14.05	74.9	14.18
	27	54.0	10.46	64.4	13.56	68.1	14.34	69.0	14.42	69.8	14.49	71.8	14.65	73.8	14.80
	29	54.0	11.17	64.4	14.49	67.0	14.91	67.9	15.00	69.0	15.09	70.9	15.25	72.9	15.40
	31	54.0	11.92	64.1	15.33	65.9	15.51	67.0	15.60	67.9	15.66	69.8	15.84	71.8	16.02
	33	54.0	12.70	63.0	15.91	65.0	16.09	65.9	16.17	67.0	16.26	69.0	16.44	70.7	16.62
35	54.0	13.54	61.9	16.49	63.9	16.68	65.0	16.77	65.9	16.86	67.9	17.06	69.8	17.24	
37	54.0	14.40	61.1	17.08	63.0	17.28	63.9	17.37	65.0	17.48	66.8	17.68	68.7	17.88	
39	54.0	15.33	60.0	17.26	61.9	17.86	63.0	17.97	63.9	18.08	65.9	18.28	67.9	18.50	
41	54.0	16.14	59.3	17.43	61.3	18.03	62.4	18.14	63.3	18.25	65.2	18.32	65.3	18.67	
43	54.0	16.55	58.9	17.51	61.0	18.08	62.1	18.22	62.6	18.27	64.1	18.35	64.5	18.71	
45	54.0	17.37	58.5	17.68	60.3	18.24	61.4	18.34	61.7	18.36	62.3	18.42	63.2	19.06	
48	54.0	17.99	58.4	18.25	59.3	18.42	60.4	18.50	60.9	18.57	60.7	18.73	61.8	19.13	
120%	-5	49.9	6.49	59.3	7.86	69.0	9.30	73.8	10.14	77.3	10.57	79.1	10.91	80.8	11.20
	-2	49.9	6.55	59.3	7.94	69.0	9.39	73.8	10.20	77.3	10.69	79.1	11.00	80.8	11.24
	0	49.9	6.61	59.3	8.00	69.0	9.50	73.8	10.22	77.3	10.79	79.1	11.06	80.8	11.26
	2	49.9	6.63	59.3	8.08	69.0	9.56	73.8	10.32	77.3	10.83	79.1	11.15	80.8	11.28
	4	49.9	6.70	59.3	8.18	69.0	9.70	73.8	10.41	77.3	10.98	79.1	11.17	80.8	11.31
	6	49.9	6.77	59.3	8.25	69.0	9.81	73.8	10.53	77.3	11.09	79.1	11.26	80.8	11.35
	8	49.9	6.83	59.3	8.33	69.0	9.95	73.8	10.66	77.3	11.21	79.1	11.30	80.8	11.40
	10	49.9	6.91	59.3	8.44	69.0	10.04	73.8	10.86	77.3	11.21	79.1	11.33	80.8	11.45
	12	49.9	7.05	59.3	8.60	69.0	10.24	73.8	11.06	76.2	11.26	78.0	11.27	79.7	11.53
	14	49.9	7.18	59.3	8.77	69.0	10.44	73.8	11.28	75.1	11.33	77.1	11.44	78.8	11.66
	16	49.9	7.31	59.3	8.95	69.0	10.64	73.4	11.48	74.2	11.50	76.0	11.63	77.8	11.84
	18	49.9	7.44	59.3	9.13	69.0	10.99	72.3	11.74	73.1	11.79	74.9	11.90	76.9	12.01
	20	49.9	7.60	59.3	9.48	69.0	11.83	71.4	12.32	72.3	12.36	74.0	12.47	75.8	12.58
	21	49.9	7.67	59.3	9.82	69.0	12.25	70.7	12.61	71.6	12.65	73.6	12.76	75.3	12.89
	23	49.9	8.20	59.3	10.52	69.0	13.12	69.8	13.16	70.7	13.23	72.5	13.36	74.2	13.47
	25	49.9	8.75	59.3	11.26	67.9	13.69	68.7	13.74	69.6	13.80	71.6	13.94	73.4	14.07
	27	49.9	9.35	59.3	12.03	67.0	14.25	67.9	14.34	68.7	14.40	70.5	14.53	72.3	14.67
	29	49.9	9.97	59.3	12.85	65.9	14.82	66.8	14.91	67.7	14.98	69.4	15.13	71.4	15.27
	31	49.9	10.64	59.3	13.71	64.8	15.42	65.9	15.49	66.8	15.58	68.5	15.73	70.3	15.89
	33	49.9	11.32	59.3	14.62	63.9	16.00	64.8	16.09	65.7	16.15	67.4	16.33	69.2	16.49
35	49.9	12.05	59.3	15.60	62.8	16.57	63.7	16.66	64.8	16.75	66.5	16.93	68.3	17.11	
37	49.9	12.83	59.3	16.62	61.9	17.17	62.8	17.26	63.7	17.35	65.5	17.53	67.2	17.72	
39	49.9	13.65	59.1	17.55	60.8	17.75	61.7	17.86	62.6	17.95	64.6	18.15	66.3	18.32	
41	49.9	14.02	58.6	17.67	60.4	17.87	61.2	17.98	62.1	18.07	64.1	18.20	64.4	18.46	
43	49.9	14.23	58.3	17.80	59.9	17.98	60.8	18.05	61.6	18.14	63.0	18.25	63.4	18.83	
45	49.9	14.40	58.0	17.96	59.3	18.15	60.1	18.22	61.1	18.28	61.7	18.30	62.8	19.24	
48	49.9	14.51	57.5	18.16	58.5	18.31	59.2	18.36	60.4	18.42	60.8	18.37	62.0	19.48	

Abbreviations:

CR: Combination ratio

TC: Total capacity (kW)

PI: Power input (compressor + outdoor fan motor) (kW)

Notes:

1. Shaded cells indicate rating condition.

Table continued on next page ...

# VMEX 460V 60Hz

Table 2-8.8: VMEX020Q8A-D36V615 cooling capacity (continued)

CR	Outdoor air temp. (°C DB)	Indoor air temp. (°C DB / °C WB)													
		20.8 / 14.0		23.3 / 16.0		25.8 / 18.0		27.0 / 19.0		28.2 / 20.0		30.7 / 22.0		32.0 / 24.0	
		TC	PI	TC	PI	TC	PI	TC	PI	TC	PI	TC	PI	TC	PI
		kW	kW	kW	kW	kW	kW	kW	kW	kW	kW	kW	kW	kW	kW
110%	-5	45.7	5.67	54.5	7.06	63.3	8.42	67.7	9.04	72.0	9.72	77.5	10.10	79.3	10.41
	-2	45.7	5.78	54.5	7.15	63.3	8.49	67.7	9.13	72.0	9.80	77.5	10.20	79.3	10.47
	0	45.7	5.83	54.5	7.19	63.3	8.56	67.7	9.19	72.0	9.91	77.5	10.30	79.3	10.59
	2	45.7	5.96	54.5	7.26	63.3	8.69	67.7	9.29	72.0	10.02	77.5	10.45	79.3	10.73
	4	45.7	6.08	54.5	7.34	63.3	8.77	67.7	9.40	72.0	10.17	77.5	10.59	79.3	10.82
	6	45.7	6.14	54.5	7.42	63.3	8.86	67.7	9.55	72.0	10.28	77.5	10.70	79.3	10.99
	8	45.7	6.20	54.5	7.54	63.3	8.96	67.7	9.65	72.0	10.40	77.5	10.78	79.3	11.11
	10	45.7	6.27	54.5	7.64	63.3	9.09	67.7	9.82	72.0	10.57	77.5	10.85	79.3	11.20
	12	45.7	6.40	54.5	7.80	63.3	9.26	67.7	10.02	72.0	10.77	76.7	11.01	78.2	11.35
	14	45.7	6.51	54.5	7.93	63.3	9.44	67.7	10.19	72.0	10.97	75.6	11.10	77.3	11.43
	16	45.7	6.63	54.5	8.09	63.3	9.62	67.7	10.39	72.0	11.19	74.7	11.23	76.2	11.55
	18	45.7	6.76	54.5	8.24	63.3	9.82	67.7	10.68	72.0	11.72	73.6	11.81	75.3	11.92
	20	45.7	6.89	54.5	8.42	63.3	10.39	67.7	11.48	70.9	12.30	72.7	12.39	74.2	12.50
	21	45.7	6.96	54.5	8.66	63.3	10.77	67.7	11.90	70.5	12.59	72.0	12.67	73.8	12.78
	23	45.7	7.29	54.5	9.28	63.3	11.54	67.7	12.76	69.4	13.14	71.2	13.27	72.7	13.38
	25	45.7	7.78	54.5	9.93	63.3	12.34	67.7	13.67	68.5	13.71	70.1	13.85	71.8	13.96
	27	45.7	8.29	54.5	10.61	63.3	13.21	66.6	14.25	67.4	14.29	69.2	14.42	70.7	14.56
	29	45.7	8.84	54.5	11.32	63.3	14.11	65.7	14.82	66.6	14.89	68.1	15.02	69.9	15.16
	31	45.7	9.42	54.5	12.08	63.3	15.07	64.6	15.40	65.5	15.47	67.2	15.60	68.7	15.75
	33	45.7	10.02	54.5	12.87	62.8	15.89	63.7	15.98	64.6	16.04	66.1	16.20	67.9	16.35
35	45.7	10.66	54.5	13.71	61.7	16.46	62.6	16.55	63.5	16.64	65.0	16.80	66.8	16.95	
37	45.7	11.34	54.5	14.60	60.8	17.06	61.7	17.13	62.4	17.22	64.1	17.39	65.7	17.55	
39	45.7	12.05	54.5	15.56	59.7	17.64	60.6	17.73	61.5	17.81	63.0	17.99	64.8	18.17	
41	45.7	12.18	54.5	15.68	59.3	17.76	60.2	17.85	61.0	17.94	62.2	18.12	62.8	18.29	
43	45.7	12.30	54.5	15.88	58.8	17.89	59.7	17.98	60.6	18.06	61.7	18.18	61.9	18.67	
45	45.7	12.70	54.5	15.97	58.2	18.05	59.1	18.19	60.0	18.23	61.1	18.68	61.3	19.10	
48	45.7	13.15	54.5	17.32	57.4	18.17	58.1	18.32	59.3	18.42	60.1	18.75	60.5	19.31	
100%	-5	41.5	5.16	49.4	6.21	57.5	7.40	61.5	7.92	65.5	8.60	73.6	9.80	77.8	10.23
	-2	41.5	5.22	49.4	6.30	57.5	7.48	61.5	8.07	65.5	8.71	73.6	9.91	77.8	10.29
	0	41.5	5.28	49.4	6.36	57.5	7.56	61.5	8.17	65.5	8.80	73.6	10.08	77.8	10.41
	2	41.5	5.38	49.4	6.45	57.5	7.64	61.5	8.28	65.5	8.89	73.6	10.23	77.8	10.57
	4	41.5	5.42	49.4	6.51	57.5	7.76	61.5	8.40	65.5	9.01	73.6	10.32	77.8	10.69
	6	41.5	5.50	49.4	6.64	57.5	7.86	61.5	8.55	65.5	9.14	73.6	10.47	77.8	10.85
	8	41.5	5.61	49.4	6.74	57.5	8.00	61.5	8.65	65.5	9.29	73.6	10.64	77.8	11.03
	10	41.5	5.67	49.4	6.87	57.5	8.13	61.5	8.80	65.5	9.46	73.6	10.81	77.8	11.19
	12	41.5	5.76	49.4	7.00	57.5	8.29	61.5	8.95	65.5	9.64	73.6	11.01	76.7	11.28
	14	41.5	5.87	49.4	7.13	57.5	8.44	61.5	9.13	65.5	9.81	73.6	11.23	75.8	11.41
	16	41.5	5.98	49.4	7.27	57.5	8.62	61.5	9.31	65.5	10.02	73.1	11.37	74.7	11.54
	18	41.5	6.09	49.4	7.40	57.5	8.77	61.5	9.48	65.5	10.21	72.3	11.74	73.8	11.83
	20	41.5	6.20	49.4	7.56	57.5	9.04	61.5	9.97	65.5	10.95	71.2	12.30	72.7	12.41
	21	41.5	6.27	49.4	7.62	57.5	9.37	61.5	10.32	65.5	11.32	70.7	12.58	72.3	12.69
	23	41.5	6.42	49.4	8.13	57.5	10.04	61.5	11.06	65.5	12.14	69.8	13.16	71.2	13.27
	25	41.5	6.85	49.4	8.69	57.5	10.75	61.5	11.85	65.5	13.01	68.8	13.74	70.3	13.85
	27	41.5	7.31	49.4	9.26	57.5	11.48	61.5	12.67	65.5	13.91	67.7	14.31	69.2	14.45
	29	41.5	7.78	49.4	9.88	57.5	12.25	61.5	13.54	65.2	14.78	66.8	14.91	68.3	15.02
	31	41.5	8.29	49.4	10.55	57.5	13.07	61.5	14.45	64.4	15.35	65.7	15.49	67.2	15.62
	33	41.5	8.80	49.4	11.23	57.5	13.94	61.5	15.42	63.3	15.93	64.8	16.06	66.3	16.22
35	41.5	9.35	49.4	11.94	57.5	14.87	<b>61.5</b>	<b>16.44</b>	62.2	16.51	63.7	16.66	65.2	16.80	
37	41.5	9.95	49.4	12.72	57.5	15.84	60.4	17.02	61.3	17.10	62.8	17.26	64.1	17.39	
39	41.5	10.57	49.4	13.52	57.5	16.86	59.5	17.59	60.2	17.68	61.7	17.84	63.3	18.01	
41	41.5	11.06	49.4	14.01	57.5	17.48	58.6	17.72	59.7	17.95	60.6	18.26	62.3	18.38	
43	41.5	11.55	49.4	14.50	57.5	17.80	57.7	17.92	59.3	18.13	61.0	18.37	61.2	18.59	
45	41.5	12.21	49.4	15.16	57.5	18.11	56.4	18.17	59.0	18.45	60.5	18.66	60.0	18.84	
48	41.5	12.75	49.4	15.69	57.5	18.13	54.1	18.38	58.9	18.78	56.8	18.85	58.7	19.01	

Abbreviations:

CR: Combination ratio

TC: Total capacity (kW)

PI: Power input (compressor + outdoor fan motor) (kW)

Notes:

1. Shaded cells indicate rating condition.

Table continued on next page ...



Table 2-8.8: VMEX020Q8A-D36V615 cooling capacity (continued)

CR	Outdoor air temp. (°C DB)	Indoor air temp. (°C DB / °C WB)													
		20.8 / 14.0		23.3 / 16.0		25.8 / 18.0		27.0 / 19.0		28.2 / 20.0		30.7 / 22.0		32.0 / 24.0	
		TC	PI	TC	PI	TC	PI	TC	PI	TC	PI	TC	PI	TC	PI
		kW	kW	kW	kW	kW	kW	kW	kW	kW	kW	kW	kW	kW	kW
90%	-5	37.3	4.57	44.6	5.48	51.8	6.46	55.4	7.05	58.9	7.50	66.1	8.62	73.4	9.88
	-2	37.3	4.61	44.6	5.53	51.8	6.55	55.4	7.15	58.9	7.59	66.1	8.71	73.4	9.97
	0	37.3	4.68	44.6	5.60	51.8	6.64	55.4	7.23	58.9	7.69	66.1	8.81	73.4	10.05
	2	37.3	4.75	44.6	5.67	51.8	6.71	55.4	7.35	58.9	7.81	66.1	8.99	73.4	10.20
	4	37.3	4.82	44.6	5.76	51.8	6.83	55.4	7.44	58.9	7.91	66.1	9.13	73.4	10.35
	6	37.3	4.89	44.6	5.87	51.8	6.95	55.4	7.59	58.9	8.05	66.1	9.27	73.4	10.52
	8	37.3	4.98	44.6	5.98	51.8	7.09	55.4	7.68	58.9	8.19	66.1	9.44	73.4	10.62
	10	37.3	5.07	44.6	6.11	51.8	7.22	55.4	7.80	58.9	8.37	66.1	9.57	73.4	10.79
	12	37.3	5.16	44.6	6.23	51.8	7.36	55.4	7.93	58.9	8.53	66.1	9.75	73.4	10.99
	14	37.3	5.25	44.6	6.34	51.8	7.49	55.4	8.09	58.9	8.68	66.1	9.93	73.4	11.19
	16	37.3	5.34	44.6	6.45	51.8	7.64	55.4	8.24	58.9	8.86	66.1	10.12	73.1	11.39
	18	37.3	5.43	44.6	6.58	51.8	7.78	55.4	8.40	58.9	9.04	66.1	10.32	72.3	11.74
	20	37.3	5.54	44.6	6.73	51.8	7.93	55.4	8.57	58.9	9.37	66.1	11.10	71.2	12.30
	21	37.3	5.58	44.6	6.78	51.8	8.06	55.4	8.86	58.9	9.70	66.1	11.50	70.7	12.58
	23	37.3	5.69	44.6	7.05	51.8	8.64	55.4	9.51	58.9	10.41	66.1	12.34	69.6	13.16
	25	37.3	6.00	44.6	7.53	51.8	9.24	55.4	10.17	58.9	11.12	66.1	13.20	68.8	13.74
	27	37.3	6.38	44.6	8.02	51.8	9.86	55.4	10.86	58.9	11.90	66.1	14.13	67.6	14.31
	29	37.3	6.80	44.6	8.55	51.8	10.52	55.4	11.59	58.9	12.72	65.5	14.78	66.8	14.89
	31	37.3	7.22	44.6	9.11	51.8	11.21	55.4	12.36	58.9	13.56	64.4	15.35	65.7	15.49
	33	37.3	7.67	44.6	9.68	51.8	11.96	55.4	13.18	58.9	14.47	63.5	15.95	64.8	16.06
35	37.3	8.15	44.6	10.30	51.8	12.74	55.4	14.05	58.9	15.42	62.4	16.53	63.7	16.66	
37	37.3	8.64	44.6	10.94	51.8	13.56	55.4	14.96	58.9	16.44	61.3	17.10	62.8	17.24	
39	37.3	9.17	44.6	11.65	51.8	14.42	55.4	15.93	58.9	17.50	60.4	17.70	61.7	17.83	
41	37.3	9.49	44.6	12.18	51.8	14.95	55.4	16.35	58.9	17.61	60.0	18.15	61.3	18.26	
43	37.3	9.94	44.6	12.71	51.8	15.48	55.4	16.77	58.9	17.98	59.7	18.39	60.8	18.54	
45	37.3	10.58	44.6	13.34	51.8	16.11	55.4	17.33	58.9	18.48	59.3	18.58	59.8	18.79	
48	37.3	11.17	44.6	13.96	51.8	16.72	55.4	17.56	58.9	18.64	58.8	18.84	58.2	19.04	
80%	-5	33.2	4.02	39.5	4.76	45.9	5.63	49.2	5.99	52.5	6.45	58.9	7.45	65.2	8.51
	-2	33.2	4.08	39.5	4.82	45.9	5.68	49.2	6.08	52.5	6.51	58.9	7.53	65.2	8.59
	0	33.2	4.15	39.5	4.87	45.9	5.75	49.2	6.15	52.5	6.63	58.9	7.63	65.2	8.71
	2	33.2	4.24	39.5	4.95	45.9	5.83	49.2	6.27	52.5	6.74	58.9	7.79	65.2	8.87
	4	33.2	4.31	39.5	5.03	45.9	5.94	49.2	6.41	52.5	6.86	58.9	7.93	65.2	8.99
	6	33.2	4.38	39.5	5.15	45.9	6.03	49.2	6.55	52.5	6.99	58.9	8.05	65.2	9.15
	8	33.2	4.46	39.5	5.27	45.9	6.18	49.2	6.66	52.5	7.15	58.9	8.16	65.2	9.32
	10	33.2	4.50	39.5	5.38	45.9	6.34	49.2	6.82	52.5	7.31	58.9	8.35	65.2	9.42
	12	33.2	4.56	39.5	5.47	45.9	6.45	49.2	6.96	52.5	7.47	58.9	8.51	65.2	9.59
	14	33.2	4.65	39.5	5.58	45.9	6.56	49.2	7.07	52.5	7.60	58.9	8.66	65.2	9.77
	16	33.2	4.72	39.5	5.67	45.9	6.69	49.2	7.20	52.5	7.73	58.9	8.84	65.2	9.95
	18	33.2	4.81	39.5	5.78	45.9	6.82	49.2	7.36	52.5	7.89	58.9	9.02	65.2	10.15
	20	33.2	4.90	39.5	5.89	45.9	6.96	49.2	7.49	52.5	8.04	58.9	9.35	65.2	10.86
	21	33.2	4.94	39.5	5.94	45.9	7.02	49.2	7.58	52.5	8.22	58.9	9.68	65.2	11.26
	23	33.2	5.03	39.5	6.07	45.9	7.36	49.2	8.06	52.5	8.80	58.9	10.37	65.2	12.08
	25	33.2	5.18	39.5	6.45	45.9	7.87	49.2	8.62	52.5	9.39	58.9	11.10	65.2	12.92
	27	33.2	5.52	39.5	6.87	45.9	8.38	49.2	9.20	52.5	10.04	58.9	11.85	65.2	13.83
	29	33.2	5.87	39.5	7.31	45.9	8.93	49.2	9.79	52.5	10.72	58.9	12.65	65.2	14.78
	31	33.2	6.23	39.5	7.78	45.9	9.51	49.2	10.44	52.5	11.43	58.9	13.52	64.1	15.36
	33	33.2	6.62	39.5	8.26	45.9	10.13	49.2	11.12	52.5	12.16	58.9	14.40	63.3	15.93
35	33.2	7.02	39.5	8.80	45.9	10.77	49.2	11.83	52.5	12.96	58.9	15.36	62.2	16.51	
37	33.2	7.44	39.5	9.33	45.9	11.46	49.2	12.61	52.5	13.80	58.9	16.37	61.3	17.08	
39	33.2	7.89	39.5	9.95	45.9	12.19	49.2	13.41	52.5	14.69	58.9	17.44	60.2	17.68	
41	33.2	8.07	39.5	10.04	45.9	12.36	49.2	13.76	52.5	14.96	58.9	17.88	59.8	17.99	
43	33.2	8.30	39.5	10.13	45.9	12.54	49.2	14.00	52.5	15.16	58.9	18.09	59.4	18.18	
45	33.2	8.54	39.5	10.24	45.9	12.78	49.2	14.29	52.5	15.43	58.9	18.29	58.7	18.48	
48	33.2	8.82	39.5	10.32	45.9	12.99	49.2	14.49	52.5	15.56	58.9	18.47	58.2	18.74	

Abbreviations:

CR: Combination ratio

TC: Total capacity (kW)

PI: Power input (compressor + outdoor fan motor) (kW)

Notes:

1. Shaded cells indicate rating condition.

Table continued on next page ...

# VMEX 460V 60Hz

Table 2-8.8: VMEX020Q8A-D36V615 cooling capacity (continued)

CR	Outdoor air temp. (°C DB)	Indoor air temp. (°C DB / °C WB)													
		20.8 / 14.0		23.3 / 16.0		25.8 / 18.0		27.0 / 19.0		28.2 / 20.0		30.7 / 22.0		32.0 / 24.0	
		TC	PI	TC	PI	TC	PI	TC	PI	TC	PI	TC	PI	TC	PI
		kW	kW	kW	kW	kW	kW	kW	kW	kW	kW	kW	kW	kW	kW
70%	-5	29.0	3.59	34.7	4.21	40.2	4.77	43.1	5.12	45.9	5.46	51.4	6.25	57.1	7.18
	-2	29.0	3.62	34.7	4.23	40.2	4.80	43.1	5.21	45.9	5.56	51.4	6.35	57.1	7.28
	0	29.0	3.64	34.7	4.29	40.2	4.90	43.1	5.31	45.9	5.66	51.4	6.47	57.1	7.38
	2	29.0	3.66	34.7	4.31	40.2	4.98	43.1	5.41	45.9	5.76	51.4	6.61	57.1	7.50
	4	29.0	3.71	34.7	4.42	40.2	5.09	43.1	5.51	45.9	5.88	51.4	6.72	57.1	7.67
	6	29.0	3.77	34.7	4.49	40.2	5.21	43.1	5.69	45.9	6.02	51.4	6.84	57.1	7.82
	8	29.0	3.84	34.7	4.62	40.2	5.33	43.1	5.77	45.9	6.15	51.4	7.03	57.1	7.97
	10	29.0	3.92	34.7	4.70	40.2	5.47	43.1	5.89	45.9	6.31	51.4	7.18	57.1	8.06
	12	29.0	4.01	34.7	4.76	40.2	5.58	43.1	6.00	45.9	6.43	51.4	7.31	57.1	8.22
	14	29.0	4.08	34.7	4.85	40.2	5.67	43.1	6.09	45.9	6.54	51.4	7.45	57.1	8.38
	16	29.0	4.14	34.7	4.94	40.2	5.78	43.1	6.23	45.9	6.67	51.4	7.58	57.1	8.53
	18	29.0	4.21	34.7	5.03	40.2	5.89	43.1	6.34	45.9	6.78	51.4	7.73	57.1	8.71
	20	29.0	4.28	34.7	5.12	40.2	6.00	43.1	6.45	45.9	6.91	51.4	7.89	57.1	8.95
	21	29.0	4.32	34.7	5.16	40.2	6.05	43.1	6.51	45.9	6.98	51.4	8.00	57.1	9.26
	23	29.0	4.39	34.7	5.25	40.2	6.18	43.1	6.74	45.9	7.33	51.4	8.57	57.1	9.93
	25	29.0	4.48	34.7	5.47	40.2	6.58	43.1	7.20	45.9	7.82	51.4	9.17	57.1	10.61
	27	29.0	4.74	34.7	5.83	40.2	7.02	43.1	7.67	45.9	8.35	51.4	9.79	57.1	11.34
	29	29.0	5.03	34.7	6.18	40.2	7.47	43.1	8.18	45.9	8.89	51.4	10.44	57.1	12.12
	31	29.0	5.32	34.7	6.56	40.2	7.95	43.1	8.69	45.9	9.46	51.4	11.12	57.1	12.92
	33	29.0	5.65	34.7	6.98	40.2	8.46	43.1	9.24	45.9	10.08	51.4	11.85	57.1	13.78
35	29.0	5.98	34.7	7.40	40.2	8.97	43.1	9.84	45.9	10.72	51.4	12.63	57.1	14.69	
37	29.0	6.31	34.7	7.84	40.2	9.55	43.1	10.44	45.9	11.41	51.4	13.45	57.1	15.64	
39	29.0	6.69	34.7	8.31	40.2	10.13	43.1	11.10	45.9	12.12	51.4	14.29	57.1	16.66	
41	29.0	6.99	34.7	8.60	40.2	10.42	43.1	11.47	45.9	12.49	51.4	14.88	57.1	17.40	
43	29.0	7.56	34.7	9.19	40.2	10.85	43.1	12.08	45.9	12.86	51.4	15.42	57.1	17.94	
45	29.0	7.72	34.7	9.39	40.2	11.08	43.1	12.28	45.9	13.50	51.4	16.26	57.1	18.63	
48	29.0	7.92	34.7	9.48	40.2	11.19	43.1	12.48	45.9	13.87	51.4	16.99	57.1	19.07	
60%	-5	24.8	3.06	29.7	3.55	34.5	4.14	36.9	4.41	39.3	4.76	44.1	5.35	49.0	6.13
	-2	24.8	3.08	29.7	3.61	34.5	4.22	36.9	4.47	39.3	4.81	44.1	5.43	49.0	6.17
	0	24.8	3.13	29.7	3.65	34.5	4.27	36.9	4.53	39.3	4.89	44.1	5.51	49.0	6.26
	2	24.8	3.18	29.7	3.74	34.5	4.35	36.9	4.62	39.3	4.96	44.1	5.62	49.0	6.34
	4	24.8	3.27	29.7	3.81	34.5	4.44	36.9	4.68	39.3	5.03	44.1	5.71	49.0	6.42
	6	24.8	3.30	29.7	3.88	34.5	4.52	36.9	4.78	39.3	5.13	44.1	5.82	49.0	6.58
	8	24.8	3.37	29.7	3.95	34.5	4.60	36.9	4.87	39.3	5.24	44.1	5.93	49.0	6.68
	10	24.8	3.43	29.7	4.03	34.5	4.67	36.9	5.01	39.3	5.34	44.1	6.05	49.0	6.78
	12	24.8	3.50	29.7	4.10	34.5	4.76	36.9	5.10	39.3	5.43	44.1	6.16	49.0	6.89
	14	24.8	3.54	29.7	4.16	34.5	4.83	36.9	5.18	39.3	5.54	44.1	6.27	49.0	7.02
	16	24.8	3.59	29.7	4.23	34.5	4.92	36.9	5.27	39.3	5.63	44.1	6.38	49.0	7.16
	18	24.8	3.66	29.7	4.30	34.5	5.01	36.9	5.36	39.3	5.74	44.1	6.49	49.0	7.29
	20	24.8	3.70	29.7	4.39	34.5	5.10	36.9	5.47	39.3	5.85	44.1	6.62	49.0	7.44
	21	24.8	3.74	29.7	4.41	34.5	5.14	36.9	5.52	39.3	5.89	44.1	6.69	49.0	7.51
	23	24.8	3.79	29.7	4.50	34.5	5.23	36.9	5.63	39.3	6.00	44.1	6.96	49.0	8.00
	25	24.8	3.85	29.7	4.56	34.5	5.43	36.9	5.89	39.3	6.38	44.1	7.42	49.0	8.53
	27	24.8	4.01	29.7	4.85	34.5	5.78	36.9	6.29	39.3	6.80	44.1	7.91	49.0	9.10
	29	24.8	4.23	29.7	5.14	34.5	6.16	36.9	6.69	39.3	7.24	44.1	8.44	49.0	9.73
	31	24.8	4.50	29.7	5.45	34.5	6.54	36.9	7.11	39.3	7.71	44.1	8.97	49.0	10.35
	33	24.8	4.74	29.7	5.78	34.5	6.93	36.9	7.55	39.3	8.20	44.1	9.55	49.0	11.03
35	24.8	5.03	29.7	6.14	34.5	7.35	36.9	8.02	39.3	8.71	44.1	10.17	49.0	11.74	
37	24.8	5.32	29.7	6.49	34.5	7.80	36.9	8.51	39.3	9.24	44.1	10.81	49.0	12.49	
39	24.8	5.60	29.7	6.87	34.5	8.26	36.9	9.02	39.3	9.81	44.1	11.48	49.0	13.29	
41	24.8	5.79	29.7	7.16	34.5	8.56	36.9	9.38	39.3	10.18	44.1	12.02	49.0	13.89	
43	24.8	5.97	29.7	7.47	34.5	8.86	36.9	9.66	39.3	10.53	44.1	12.53	49.0	14.50	
45	24.8	6.25	29.7	7.84	34.5	9.23	36.9	10.02	39.3	11.05	44.1	13.09	49.0	15.30	
48	24.8	6.48	29.7	8.19	34.5	9.54	36.9	10.28	39.3	11.48	44.1	13.57	49.0	16.02	

**Abbreviations:**

CR: Combination ratio

TC: Total capacity (kW)

PI: Power input (compressor + outdoor fan motor) (kW)

**Notes:**

1. Shaded cells indicate rating condition.

Table continued on next page ...

Table 2-8.8: VMEX020Q8A-D36V615 cooling capacity (continued)

CR	Outdoor air temp. (°C DB)	Indoor air temp. (°C DB / °C WB)													
		20.8 / 14.0		23.3 / 16.0		25.8 / 18.0		27.0 / 19.0		28.2 / 20.0		30.7 / 22.0		32.0 / 24.0	
		TC	PI	TC	PI	TC	PI	TC	PI	TC	PI	TC	PI	TC	PI
		kW	kW	kW	kW	kW	kW	kW	kW	kW	kW	kW	kW	kW	kW
50%	-5	20.8	2.66	24.8	3.08	28.8	3.53	30.8	3.70	32.7	3.90	36.7	4.44	40.9	4.79
	-2	20.8	2.68	24.8	3.14	28.8	3.57	30.8	3.75	32.7	3.97	36.7	4.50	40.9	4.85
	0	20.8	2.72	24.8	3.19	28.8	3.64	30.8	3.80	32.7	4.02	36.7	4.57	40.9	4.93
	2	20.8	2.76	24.8	3.23	28.8	3.70	30.8	3.86	32.7	4.09	36.7	4.59	40.9	5.03
	4	20.8	2.79	24.8	3.29	28.8	3.74	30.8	3.90	32.7	4.17	36.7	4.71	40.9	5.16
	6	20.8	2.84	24.8	3.34	28.8	3.80	30.8	3.99	32.7	4.25	36.7	4.78	40.9	5.31
	8	20.8	2.91	24.8	3.40	28.8	3.86	30.8	4.08	32.7	4.31	36.7	4.86	40.9	5.48
	10	20.8	2.97	24.8	3.43	28.8	3.92	30.8	4.15	32.7	4.43	36.7	4.98	40.9	5.56
	12	20.8	2.99	24.8	3.48	28.8	3.99	30.8	4.23	32.7	4.52	36.7	5.07	40.9	5.65
	14	20.8	3.04	24.8	3.52	28.8	4.03	30.8	4.32	32.7	4.59	36.7	5.16	40.9	5.76
	16	20.8	3.08	24.8	3.57	28.8	4.10	30.8	4.39	32.7	4.65	36.7	5.25	40.9	5.85
	18	20.8	3.12	24.8	3.63	28.8	4.17	30.8	4.45	32.7	4.74	36.7	5.34	40.9	5.96
	20	20.8	3.17	24.8	3.68	28.8	4.23	30.8	4.52	32.7	4.83	36.7	5.43	40.9	6.07
	21	20.8	3.19	24.8	3.72	28.8	4.28	30.8	4.56	32.7	4.87	36.7	5.49	40.9	6.14
	23	20.8	3.23	24.8	3.77	28.8	4.34	30.8	4.65	32.7	4.96	36.7	5.58	40.9	6.27
	25	20.8	3.28	24.8	3.83	28.8	4.43	30.8	4.74	32.7	5.12	36.7	5.87	40.9	6.69
	27	20.8	3.35	24.8	3.99	28.8	4.67	30.8	5.05	32.7	5.43	36.7	6.25	40.9	7.13
	29	20.8	3.52	24.8	4.21	28.8	4.96	30.8	5.36	32.7	5.78	36.7	6.65	40.9	7.60
	31	20.8	3.72	24.8	4.45	28.8	5.25	30.8	5.69	32.7	6.14	36.7	7.07	40.9	8.09
	33	20.8	3.94	24.8	4.72	28.8	5.58	30.8	6.03	32.7	6.51	36.7	7.51	40.9	8.60
35	20.8	4.17	24.8	4.98	28.8	5.89	30.8	6.38	32.7	6.89	36.7	7.98	40.9	9.13	
37	20.8	4.39	24.8	5.27	28.8	6.25	30.8	6.76	32.7	7.31	36.7	8.46	40.9	9.70	
39	20.8	4.63	24.8	5.56	28.8	6.60	30.8	7.16	32.7	7.75	36.7	8.97	40.9	10.30	
41	20.8	4.82	24.8	5.80	28.8	6.84	30.8	7.49	32.7	8.09	36.7	9.45	40.9	10.78	
43	20.8	5.14	24.8	6.20	28.8	7.08	30.8	7.83	32.7	8.30	36.7	9.93	40.9	11.26	
45	20.8	5.26	24.8	6.36	28.8	7.56	30.8	8.43	32.7	8.65	36.7	10.89	40.9	12.22	
48	20.8	5.38	24.8	6.54	28.8	8.00	30.8	8.97	32.7	9.03	36.7	11.76	40.9	13.15	

Abbreviations:

CR: Combination ratio

TC: Total capacity (kW)

PI: Power input (compressor + outdoor fan motor) (kW)

Notes:

1. Shaded cells indicate rating condition.

# VMEX 460V 60Hz

## 8.2 Heating Capacity Tables

Table 2-8.9: VMEX008Q8A-D13V224 heating

CR	Outdoor air temp.		Indoor air temp. °C DB											
			16.0		18.0		20.0		21.0		22.0		24.0	
	°C DB	°C WB	TC kW	PI kW	TC kW	PI kW	TC kW	PI kW	TC kW	PI kW	TC kW	PI kW	TC kW	PI kW
130%	-19.8	-20.0	17.5	3.41	17.4	3.64	17.3	3.89	17.3	4.01	17.2	4.13	17.2	4.37
	-18.8	-19.0	17.7	3.48	17.7	3.72	17.7	3.96	17.6	4.07	17.6	4.19	17.5	4.43
	-16.7	-17.0	18.4	3.64	18.3	3.87	18.3	4.10	18.3	4.21	18.3	4.33	18.2	4.55
	-13.7	-15.0	19.2	3.81	19.1	4.03	19.0	4.25	19.0	4.36	18.9	4.47	18.9	4.69
	-11.8	-13.0	20.0	3.98	20.0	4.19	19.9	4.40	19.8	4.51	19.8	4.61	19.7	4.82
	-9.8	-11.0	20.9	4.16	20.8	4.36	20.7	4.56	20.7	4.66	20.7	4.76	20.7	4.96
	-9.5	-10.0	21.4	4.24	21.3	4.44	21.3	4.63	21.3	4.73	21.2	4.83	21.2	5.02
	-8.5	-9.1	21.9	4.32	21.8	4.51	21.8	4.70	21.7	4.79	21.7	4.89	21.6	5.08
	-7.0	-7.6	22.6	4.44	22.6	4.63	22.5	4.81	22.5	4.91	22.5	4.99	22.4	5.18
	-5.0	-5.6	23.8	4.61	23.7	4.79	23.7	4.96	23.7	5.05	23.6	5.13	23.6	5.31
	-3.0	-3.7	24.9	4.76	24.9	4.93	24.9	5.10	24.8	5.18	24.8	5.26	24.7	5.43
	0.0	-0.7	26.9	4.99	26.9	5.15	26.8	5.30	26.8	5.36	26.7	5.46	26.7	5.61
	3.0	2.2	29.1	5.20	29.0	5.35	28.9	5.49	28.9	5.56	28.9	5.63	28.8	5.77
	5.0	4.1	30.5	5.33	30.4	5.47	30.4	5.60	30.3	5.67	30.3	5.74	30.3	5.87
	7.0	6.0	32.1	5.46	32.0	5.58	32.0	5.72	31.9	5.78	31.9	5.84	30.6	5.61
	9.0	7.9	33.7	5.57	33.6	5.70	33.6	5.82	33.5	5.88	32.8	5.75	30.6	5.27
11.0	9.8	35.4	5.68	35.3	5.80	35.1	5.87	33.9	5.64	32.8	5.41	30.6	4.96	
13.0	11.8	37.3	5.79	37.2	5.90	35.1	5.50	33.9	5.28	32.8	5.08	30.6	4.66	
15.0	13.7	39.1	5.89	37.4	5.59	35.1	5.18	33.9	4.98	32.8	4.78	30.6	4.39	
120%	-19.8	-20.0	17.4	3.73	17.3	3.95	17.2	4.18	17.2	4.28	17.2	4.39	17.1	4.62
	-18.8	-19.0	17.7	3.80	17.6	4.02	17.6	4.24	17.5	4.34	17.5	4.46	17.4	4.68
	-16.7	-17.0	18.3	3.95	18.3	4.16	18.1	4.37	18.2	4.48	18.2	4.58	18.1	4.79
	-13.7	-15.0	19.1	4.11	19.0	4.31	18.9	4.51	18.9	4.61	18.9	4.71	18.9	4.91
	-11.8	-13.0	19.9	4.26	19.9	4.46	19.8	4.65	19.8	4.75	19.7	4.84	19.7	5.04
	-9.8	-11.0	20.8	4.43	20.7	4.61	20.7	4.80	20.7	4.89	20.7	4.98	20.6	5.16
	-9.5	-10.0	21.3	4.51	21.3	4.69	21.2	4.86	21.2	4.96	21.2	5.05	21.1	5.23
	-8.5	-9.1	21.8	4.58	21.7	4.75	21.7	4.93	21.6	5.01	21.6	5.11	21.5	5.28
	-7.0	-7.6	22.5	4.69	22.5	4.86	22.5	5.03	22.5	5.12	22.4	5.20	22.4	5.37
	-5.0	-5.6	23.7	4.84	23.7	5.01	23.6	5.17	23.6	5.25	23.6	5.33	23.5	5.49
	-3.0	-3.7	24.9	4.99	24.9	5.15	24.8	5.30	24.8	5.37	24.7	5.45	24.7	5.60
	0.0	-0.7	26.8	5.20	26.8	5.35	26.7	5.48	26.7	5.56	26.7	5.63	26.7	5.77
	3.0	2.2	29.0	5.40	28.9	5.53	28.9	5.66	28.8	5.73	28.8	5.79	28.2	5.76
	5.0	4.1	30.4	5.51	30.3	5.64	30.3	5.77	30.3	5.83	30.3	5.89	28.2	5.41
	7.0	6.0	32.0	5.63	32.0	5.75	31.9	5.87	31.4	5.78	30.3	5.55	28.2	5.09
	9.0	7.9	33.6	5.74	33.5	5.85	32.4	5.66	31.4	5.43	30.3	5.21	28.2	4.79
11.0	9.8	35.3	5.84	34.5	5.74	32.4	5.32	31.4	5.11	30.3	4.91	28.2	4.51	
13.0	11.8	36.6	5.78	34.5	5.38	32.4	4.99	31.4	4.80	30.3	4.61	28.2	4.24	
15.0	13.7	36.6	5.45	34.5	5.07	32.4	4.71	31.4	4.53	30.3	4.35	28.2	4.01	
110%	-19.8	-20.0	17.3	4.06	17.2	4.26	17.1	4.46	17.1	4.56	17.1	4.66	17.1	4.87
	-18.8	-19.0	17.6	4.12	17.5	4.32	17.5	4.52	17.5	4.62	17.4	4.72	17.4	4.92
	-16.7	-17.0	18.3	4.26	18.2	4.45	18.4	4.64	18.1	4.74	18.1	4.84	18.0	5.03
	-13.7	-15.0	19.0	4.40	18.9	4.59	18.9	4.77	18.9	4.86	18.9	4.96	18.8	5.14
	-11.8	-13.0	19.8	4.55	19.8	4.73	19.7	4.90	19.7	4.99	19.6	5.08	19.6	5.26
	-9.8	-11.0	20.7	4.70	20.7	4.86	20.7	5.03	20.6	5.12	20.6	5.20	20.6	5.37
	-9.5	-10.0	21.3	4.77	21.2	4.93	21.1	5.10	21.1	5.18	21.1	5.26	21.0	5.43
	-8.5	-9.1	21.7	4.83	21.6	5.00	21.6	5.16	21.5	5.24	21.5	5.32	21.5	5.48
	-7.0	-7.6	22.5	4.95	22.5	5.10	22.4	5.25	22.4	5.33	22.4	5.41	22.3	5.56
	-5.0	-5.6	23.7	5.08	23.6	5.23	23.5	5.38	23.5	5.45	23.5	5.53	23.4	5.68
	-3.0	-3.7	24.8	5.21	24.8	5.35	24.7	5.50	24.7	5.56	24.6	5.63	24.6	5.78
	0.0	-0.7	26.7	5.41	26.7	5.54	26.7	5.67	26.7	5.73	26.7	5.80	25.9	5.69
	3.0	2.2	28.9	5.59	28.8	5.71	28.8	5.83	28.7	5.88	27.8	5.65	25.9	5.18
	5.0	4.1	30.3	5.70	30.3	5.82	29.7	5.76	28.7	5.53	27.8	5.31	25.9	4.87
	7.0	6.0	31.9	5.80	31.6	5.84	29.7	5.41	28.7	5.20	27.8	4.99	25.9	4.58
	9.0	7.9	33.5	5.90	31.6	5.49	29.7	5.09	28.7	4.89	27.8	4.70	25.9	4.32
11.0	9.8	33.5	5.55	31.6	5.16	29.7	4.79	28.7	4.61	27.8	4.43	25.9	4.08	
13.0	11.8	33.5	5.20	31.6	4.84	29.7	4.50	28.7	4.33	27.8	4.16	25.9	3.84	
15.0	13.7	33.5	4.62	31.6	4.57	29.7	4.25	28.7	4.09	27.8	3.94	25.9	3.63	

Abbreviations:

CR: Combination ratio

TC: Total capacity (kW)

PI: Power input (compressor + outdoor fan motor) (kW)

Notes:

1. Shaded cells indicate rating condition.

Table continued on next page ...

Table 2-8.9 VMEX008Q8A-D13V224 heating capacity (continued)

CR	Outdoor air temp.		Indoor air temp. °C DB											
			16.0		18.0		20.0		21.0		22.0		24.0	
	°C DB	°C WB	TC	PI	TC	PI	TC	PI	TC	PI	TC	PI	TC	PI
100%	-19.8	-20.0	17.2	4.38	17.1	4.56	17.1	4.75	17.1	4.85	17.1	4.93	17.0	5.12
	-18.8	-19.0	17.5	4.44	17.5	4.62	17.4	4.80	17.4	4.90	17.3	4.99	17.3	5.17
	-16.7	-17.0	18.2	4.56	18.1	4.74	18.1	4.91	18.0	5.00	18.0	5.09	18.0	5.26
	-13.7	-15.0	18.9	4.69	18.9	4.86	18.8	5.03	18.8	5.12	18.8	5.20	18.7	5.37
	-11.8	-13.0	19.7	4.83	19.7	4.99	19.6	5.15	19.6	5.23	19.6	5.31	19.5	5.48
	-9.8	-11.0	20.7	4.96	20.6	5.12	20.6	5.27	20.6	5.35	20.5	5.43	20.5	5.58
	-9.5	-10.0	21.2	5.03	21.1	5.18	21.1	5.33	21.0	5.41	21.0	5.48	20.9	5.63
	-8.5	-9.1	21.6	5.09	21.5	5.24	21.5	5.38	21.5	5.46	21.4	5.53	21.4	5.68
	-7.0	-7.6	22.4	5.19	22.4	5.33	22.3	5.47	22.3	5.55	22.3	5.61	22.2	5.76
	-5.0	-5.6	23.6	5.32	23.5	5.45	23.5	5.59	23.4	5.65	23.4	5.72	23.3	5.86
	-3.0	-3.7	24.7	5.44	24.7	5.49	24.6	5.70	24.6	5.76	24.6	5.82	23.6	5.58
	0.0	-0.7	26.7	5.61	26.7	5.73	26.6	5.85	26.1	5.76	25.3	5.52	23.6	5.06
	3.0	2.2	28.8	5.78	28.7	5.88	27.0	5.45	26.1	5.23	25.3	5.03	23.6	4.61
	5.0	4.1	30.3	5.88	28.7	5.53	27.0	5.12	26.1	4.93	25.3	4.73	23.6	4.35
	7.0	6.0	30.4	5.58	28.7	5.20	27.0	4.82	26.1	4.64	25.3	4.46	23.6	4.10
9.0	7.9	30.4	5.25	28.7	4.89	27.0	4.54	26.1	4.31	25.3	4.20	23.6	3.87	
11.0	9.8	30.4	4.94	28.7	4.61	27.0	4.28	26.1	4.12	25.3	3.96	23.6	3.66	
13.0	11.8	30.4	4.64	28.7	4.33	27.0	4.03	26.1	3.88	25.3	3.74	23.6	3.45	
15.0	13.7	30.4	4.38	28.7	4.09	27.0	3.81	26.1	3.67	25.3	3.53	23.6	3.27	
90%	-19.8	-20.0	17.1	4.71	17.0	4.87	17.0	5.04	16.9	5.12	16.9	5.21	16.9	5.37
	-18.8	-19.0	17.4	4.76	17.4	4.93	17.3	5.09	17.3	5.17	17.3	5.25	17.2	5.41
	-16.7	-17.0	18.1	4.88	18.0	5.03	18.0	5.19	18.0	5.27	17.9	5.35	17.9	5.50
	-13.7	-15.0	18.8	5.00	18.7	5.15	18.7	5.30	18.7	5.37	18.7	5.45	18.7	5.60
	-11.8	-13.0	19.6	5.11	19.6	5.26	19.5	5.40	19.5	5.48	19.5	5.55	19.4	5.69
	-9.8	-11.0	20.5	5.23	20.5	5.37	20.4	5.51	20.4	5.58	20.4	5.65	20.4	5.79
	-9.5	-10.0	21.0	5.30	21.0	5.43	21.0	5.57	20.9	5.63	20.9	5.70	20.9	5.83
	-8.5	-9.1	21.5	5.35	21.5	5.48	21.4	5.61	21.4	5.68	21.4	5.75	21.1	5.80
	-7.0	-7.6	22.2	5.44	22.2	5.57	22.2	5.70	22.2	5.76	22.2	5.82	21.1	5.54
	-5.0	-5.6	23.4	5.56	23.4	5.68	23.4	5.80	23.3	5.86	22.7	5.68	21.1	5.21
	-3.0	-3.7	24.6	5.67	24.6	5.78	24.3	5.80	23.4	5.57	22.7	5.35	21.1	4.91
	0.0	-0.7	26.6	5.83	25.8	5.68	24.3	5.26	23.4	5.06	22.7	4.86	21.1	4.46
	3.0	2.2	27.4	5.55	25.8	5.17	24.3	4.79	23.4	4.61	22.7	4.43	21.1	4.08
	5.0	4.1	27.4	5.22	25.8	4.86	24.3	4.52	23.4	4.34	22.7	4.18	21.1	3.85
	7.0	6.0	27.4	4.91	25.8	4.58	24.3	4.26	23.4	4.10	22.7	3.94	21.1	3.64
9.0	7.9	27.4	4.63	25.8	4.31	24.3	4.01	23.4	3.87	22.7	3.72	21.1	3.44	
11.0	9.8	27.4	4.36	25.8	4.07	24.3	3.79	23.4	3.66	22.7	3.52	21.1	3.25	
13.0	11.8	27.4	4.10	25.8	3.84	24.3	3.57	23.4	3.45	22.7	3.32	21.1	3.07	
15.0	13.7	27.4	3.87	25.8	3.62	24.3	3.39	23.4	3.27	22.7	3.15	21.1	2.92	
80%	-19.8	-20.0	17.1	5.03	17.0	5.18	17.0	5.33	17.0	5.40	16.9	5.48	16.9	5.62
	-18.8	-19.0	17.3	5.08	17.3	5.23	17.2	5.37	17.2	5.45	17.2	5.51	17.1	5.66
	-16.7	-17.0	18.0	5.18	17.9	5.32	17.9	5.46	17.9	5.53	17.9	5.60	17.8	5.74
	-13.7	-15.0	18.8	5.29	18.7	5.42	18.7	5.56	18.7	5.62	18.6	5.69	18.6	5.83
	-11.8	-13.0	19.5	5.40	19.5	5.53	19.5	5.65	19.5	5.71	19.5	5.78	18.9	5.63
	-9.8	-11.0	20.5	5.50	20.5	5.63	20.4	5.75	20.4	5.81	20.2	5.80	18.9	5.31
	-9.5	-10.0	21.0	5.56	20.9	5.68	20.9	5.80	20.9	5.86	20.2	5.63	18.9	5.16
	-8.5	-9.1	21.4	5.61	19.9	5.73	21.3	5.84	20.9	5.71	20.2	5.48	18.9	5.02
	-7.0	-7.6	22.2	5.69	22.2	5.80	21.6	5.68	20.9	5.45	20.2	5.23	18.9	4.80
	-5.0	-5.6	23.4	5.79	23.0	5.76	21.6	5.33	20.9	5.13	20.2	4.92	18.9	4.52
	-3.0	-3.7	24.3	5.82	23.0	5.42	21.6	5.02	20.9	4.83	20.2	4.64	18.9	4.27
	0.0	-0.7	24.3	5.28	23.0	4.92	21.6	4.57	20.9	4.40	20.2	4.23	18.9	3.89
	3.0	2.2	24.3	4.81	23.0	4.49	21.6	4.18	20.9	4.02	20.2	3.87	18.9	3.57
	5.0	4.1	24.3	4.53	23.0	4.23	21.6	3.94	20.9	3.79	20.2	3.66	18.9	3.37
	7.0	6.0	24.3	4.27	23.0	3.99	21.6	3.72	20.9	3.59	20.2	3.46	18.9	3.19
9.0	7.9	24.3	4.03	23.0	3.77	21.6	3.51	20.9	3.39	20.2	3.27	18.9	3.02	
11.0	9.8	24.3	3.81	23.0	3.56	21.6	3.32	20.9	3.21	20.2	3.09	18.9	2.87	
13.0	11.8	24.3	3.59	23.0	3.36	21.6	3.14	20.9	3.03	20.2	2.92	18.9	2.71	
15.0	13.7	24.3	3.39	23.0	3.19	21.6	2.98	20.9	2.87	20.2	2.77	18.9	2.58	

Abbreviations:

CR: Combination ratio

TC: Total capacity (kW)

PI: Power input (compressor + outdoor fan motor) (kW)

Notes:

1. Shaded cells indicate rating condition.

Table continued on next page ...

# VMEX 460V 60Hz

Table 2-8.9 VMEX008Q8A-D13V224 heating capacity (continued)

CR	Outdoor air temp.		Indoor air temp. °C DB											
			16.0		18.0		20.0		21.0		22.0		24.0	
	°C DB	°C WB	TC	PI	TC	PI	TC	PI	TC	PI	TC	PI	TC	PI
70%	-19.8	-20.0	16.9	5.36	16.8	5.48	16.8	5.61	16.8	5.68	16.8	5.75	16.4	5.68
	-18.8	-19.0	17.2	5.40	17.2	5.53	17.1	5.65	17.1	5.71	17.1	5.78	16.4	5.56
	-16.7	-17.0	17.9	5.49	17.9	5.61	17.8	5.73	17.8	5.80	17.6	5.16	16.4	5.31
	-13.7	-15.0	18.6	5.58	18.6	5.70	18.6	5.82	18.2	5.73	17.6	5.50	16.4	5.05
	-11.8	-13.0	19.4	5.68	19.4	5.79	18.9	5.65	18.2	5.43	17.6	5.21	16.4	4.78
	-9.8	-11.0	20.4	5.77	20.1	5.76	18.9	5.34	18.2	5.13	17.6	4.93	16.4	4.53
	-9.5	-10.0	20.9	5.82	20.1	5.60	18.9	5.18	18.2	4.98	17.6	4.79	16.4	4.40
	-8.5	-9.1	21.3	5.85	20.1	5.45	18.9	5.05	18.2	4.85	17.6	4.66	16.4	4.29
	-7.0	-7.6	21.3	5.59	20.1	5.20	18.9	4.83	18.2	4.64	17.6	4.46	16.4	4.11
	-5.0	-5.6	21.3	5.25	20.1	4.89	18.9	4.54	18.2	4.37	17.6	5.16	16.4	3.87
	-3.0	-3.7	21.3	4.95	20.1	4.61	18.9	4.29	18.2	4.12	17.6	3.97	16.4	3.66
	0.0	-0.7	21.3	4.50	20.1	4.21	18.9	3.91	18.2	3.77	17.6	3.63	16.4	3.36
	3.0	2.2	21.3	4.11	20.1	3.85	18.9	3.59	18.2	3.46	17.6	3.33	16.4	3.08
	5.0	4.1	21.3	3.88	20.1	3.63	18.9	3.39	18.2	3.27	17.6	3.15	16.4	2.92
	7.0	6.0	21.3	3.67	20.1	3.44	18.9	3.20	18.2	3.09	17.6	2.99	16.4	2.77
9.0	7.9	21.3	3.47	20.1	3.25	18.9	3.04	18.2	2.93	17.6	2.83	16.4	2.62	
11.0	9.8	21.3	3.28	20.1	3.07	18.9	2.88	18.2	2.78	17.6	2.69	16.4	2.49	
13.0	11.8	21.3	3.10	20.1	2.91	18.9	2.72	18.2	2.64	17.6	2.54	16.4	2.37	
15.0	13.7	21.3	2.94	20.1	2.76	18.9	2.59	18.2	2.50	17.6	2.42	16.4	2.25	
60%	-19.8	-20.0	16.9	5.68	16.8	5.79	16.2	5.57	15.7	5.35	15.2	5.14	14.1	4.71
	-18.8	-19.0	17.1	5.72	17.1	5.83	16.2	5.45	15.7	5.24	15.2	5.03	14.1	4.61
	-16.7	-17.0	17.8	5.80	17.2	5.61	16.2	5.20	15.7	5.00	15.2	4.80	14.1	4.41
	-13.7	-15.0	18.3	5.73	17.2	5.33	16.2	4.94	15.7	4.76	15.2	4.57	14.1	4.20
	-11.8	-13.0	18.3	5.43	17.2	5.05	16.2	4.69	15.7	4.51	15.2	4.34	14.1	4.01
	-9.8	-11.0	18.3	5.13	17.2	4.78	16.2	4.44	15.7	4.27	15.2	4.11	14.1	3.79
	-9.5	-10.0	18.3	4.98	17.2	4.64	16.2	4.31	15.7	4.16	15.2	3.99	14.1	3.68
	-8.5	-9.1	18.3	4.85	17.2	4.53	16.2	4.21	15.7	4.05	15.2	3.89	14.1	3.59
	-7.0	-7.6	18.3	4.64	17.2	4.33	16.2	4.02	15.7	3.88	15.2	3.73	14.1	3.45
	-5.0	-5.6	18.3	4.37	17.2	4.08	16.2	3.80	15.7	3.66	15.2	3.52	14.1	3.26
	-3.0	-3.7	18.3	4.12	17.2	3.86	16.2	3.59	15.7	3.47	15.2	3.34	14.1	3.09
	0.0	-0.7	18.3	3.77	17.2	3.53	16.2	3.29	15.7	3.18	15.2	3.06	14.1	2.84
	3.0	2.2	18.3	3.46	17.2	3.24	16.2	3.03	15.7	2.92	15.2	2.82	14.1	2.62
	5.0	4.1	18.3	3.27	17.2	3.07	16.2	2.87	15.7	2.77	15.2	2.67	14.1	2.48
	7.0	6.0	18.3	3.09	17.2	2.90	16.2	2.72	15.7	2.63	15.2	2.54	14.1	2.36
9.0	7.9	18.3	2.93	17.2	2.75	16.2	2.58	15.7	2.50	15.2	2.41	14.1	2.25	
11.0	9.8	18.3	2.78	17.2	2.62	16.2	2.45	15.7	2.37	15.2	2.29	14.1	2.14	
13.0	11.8	18.3	2.63	17.2	2.48	16.2	2.33	15.7	2.25	15.2	2.18	14.1	2.03	
15.0	13.7	18.3	2.50	17.2	2.35	16.2	2.22	15.7	2.15	15.2	2.08	14.1	1.94	
50%	-19.8	-20.0	15.2	5.17	14.4	4.81	13.5	4.47	13.0	4.31	12.6	4.14	11.7	3.81
	-18.8	-19.0	15.2	5.06	14.4	4.71	13.5	4.38	13.0	4.21	12.6	4.05	11.7	3.74
	-16.7	-17.0	15.2	4.83	14.4	4.50	13.5	4.19	13.0	4.03	12.6	3.88	11.7	3.58
	-13.7	-15.0	15.2	4.59	14.4	4.29	13.5	3.99	13.0	3.84	12.6	3.70	11.7	3.42
	-11.8	-13.0	15.2	4.36	14.4	4.07	13.5	3.79	13.0	3.66	12.6	3.52	11.7	3.25
	-9.8	-11.0	15.2	4.13	14.4	3.86	13.5	3.60	13.0	3.47	12.6	3.34	11.7	3.09
	-9.5	-10.0	15.2	4.02	14.4	3.76	13.5	3.51	13.0	3.38	12.6	3.25	11.7	3.01
	-8.5	-9.1	15.2	3.92	14.4	3.67	13.5	3.42	13.0	3.30	12.6	3.18	11.7	2.94
	-7.0	-7.6	15.2	3.76	14.4	3.52	13.5	3.28	13.0	3.17	12.6	3.05	11.7	2.83
	-5.0	-5.6	15.2	3.54	14.4	3.32	13.5	3.10	13.0	3.00	12.6	2.89	11.7	2.68
	-3.0	-3.7	15.2	3.36	14.4	3.15	13.5	2.94	13.0	2.84	12.6	2.74	11.7	2.55
	0.0	-0.7	15.2	3.08	14.4	2.89	13.5	2.71	13.0	2.62	12.6	2.53	11.7	2.35
	3.0	2.2	15.2	2.84	14.4	2.67	13.5	2.50	13.0	2.42	12.6	2.33	11.7	2.18
	5.0	4.1	15.2	2.69	14.4	2.53	13.5	2.37	13.0	2.30	12.6	2.22	11.7	2.07
	7.0	6.0	15.2	2.55	14.4	2.40	13.5	2.26	13.0	2.18	12.6	2.12	11.7	1.98
9.0	7.9	15.2	2.42	14.4	2.28	13.5	2.15	13.0	2.08	12.6	2.02	11.7	1.88	
11.0	9.8	15.2	2.30	14.4	2.17	13.5	2.05	13.0	1.98	12.6	1.92	11.7	1.80	
13.0	11.8	15.2	2.19	14.4	2.07	13.5	1.95	13.0	1.89	12.6	1.83	11.7	1.72	
15.0	13.7	15.2	2.08	14.4	1.97	13.5	1.86	13.0	1.80	12.6	1.75	11.7	1.64	

Abbreviations:

CR: Combination ratio

TC: Total capacity (kW)

PI: Power input (compressor + outdoor fan motor) (kW)

Notes:

1. Shaded cells indicate rating condition.

Table 2-8.10: VMEX009Q8A-D16V280 heating capacity

CR	Outdoor air temp.		Indoor air temp. °C DB											
			16.0		18.0		20.0		21.0		22.0		24.0	
	°C DB	°C WB	TC	PI	TC	PI	TC	PI	TC	PI	TC	PI	TC	PI
130%	-19.8	-20.0	20.4	4.20	20.3	4.49	20.2	4.79	20.2	4.94	20.1	5.08	20.1	5.38
	-18.8	-19.0	20.7	4.29	20.6	4.58	20.6	4.88	20.5	5.02	20.5	5.16	20.4	5.45
	-16.7	-17.0	21.5	4.49	21.4	4.77	21.3	5.05	21.3	5.19	21.3	5.33	21.2	5.61
	-13.7	-15.0	22.4	4.70	22.3	4.97	22.2	5.24	22.2	5.37	22.1	5.51	22.1	5.78
	-11.8	-13.0	23.3	4.91	23.3	5.17	23.2	5.42	23.1	5.55	23.1	5.69	23.0	5.94
	-9.8	-11.0	24.4	5.12	24.3	5.37	24.2	5.62	24.2	5.74	24.2	5.86	24.1	6.11
	-9.5	-10.0	25.0	5.23	24.9	5.47	24.8	5.71	24.8	5.83	24.7	5.95	24.7	6.19
	-8.5	-9.1	25.5	5.32	25.4	5.55	25.4	5.79	25.3	5.91	25.3	6.02	25.2	6.26
	-7.0	-7.6	26.4	5.48	26.4	5.71	26.3	5.93	26.3	6.05	26.2	6.16	26.1	6.39
	-5.0	-5.6	27.8	5.69	27.7	5.90	27.6	6.12	27.6	6.23	27.5	6.33	27.5	6.54
	-3.0	-3.7	29.1	5.87	29.0	6.08	29.0	6.28	28.9	6.39	28.9	6.49	28.8	6.69
	0.0	-0.7	31.4	6.16	31.4	6.35	31.3	6.53	31.3	6.60	31.2	6.73	31.2	6.91
	3.0	2.2	33.9	6.41	33.8	6.59	33.7	6.77	33.7	6.85	33.7	6.94	33.6	7.11
	5.0	4.1	35.6	6.57	35.5	6.74	35.5	6.90	35.4	6.99	35.4	7.07	35.3	7.24
	7.0	6.0	37.4	6.73	37.3	6.88	37.3	7.04	37.2	7.12	37.2	7.20	35.7	6.91
9.0	7.9	39.3	6.87	39.2	7.02	39.2	7.17	39.1	7.24	38.3	7.09	35.7	6.50	
11.0	9.8	41.3	7.00	41.2	7.14	41.0	7.24	39.6	6.95	38.3	6.66	35.7	6.12	
13.0	11.8	43.5	7.14	43.4	7.27	41.0	6.78	39.6	6.51	38.3	6.26	35.7	5.74	
15.0	13.7	45.6	7.26	43.6	6.89	41.0	6.39	39.6	6.14	38.3	5.89	35.7	5.42	
120%	-19.8	-20.0	20.3	4.60	20.2	4.87	20.1	5.15	20.1	5.28	20.1	5.42	20.0	5.69
	-18.8	-19.0	20.6	4.68	20.5	4.95	20.5	5.22	20.4	5.35	20.4	5.49	20.3	5.76
	-16.7	-17.0	21.4	4.87	21.3	5.13	21.2	5.38	21.2	5.52	21.2	5.65	21.1	5.90
	-13.7	-15.0	22.3	5.06	22.2	5.31	22.1	5.55	22.1	5.69	22.1	5.81	22.0	6.06
	-11.8	-13.0	23.2	5.25	23.2	5.49	23.1	5.73	23.1	5.85	23.0	5.97	23.0	6.21
	-9.8	-11.0	24.3	5.45	24.2	5.68	24.2	5.91	24.1	6.02	24.1	6.13	24.0	6.36
	-9.5	-10.0	24.9	5.55	24.8	5.78	24.7	5.99	24.7	6.11	24.7	6.22	24.6	6.44
	-8.5	-9.1	25.4	5.64	25.3	5.85	25.3	6.07	25.2	6.18	25.2	6.30	25.1	6.51
	-7.0	-7.6	26.3	5.79	26.3	5.99	26.2	6.20	26.2	6.31	26.1	6.41	26.1	6.62
	-5.0	-5.6	27.7	5.97	27.6	6.17	27.5	6.37	27.5	6.47	27.5	6.57	27.4	6.77
	-3.0	-3.7	29.0	6.15	29.0	6.34	28.9	6.53	28.9	6.62	28.8	6.72	28.8	6.90
	0.0	-0.7	31.3	6.41	31.3	6.59	31.2	6.76	31.2	6.85	31.1	6.93	31.1	7.11
	3.0	2.2	33.8	6.65	33.7	6.81	33.7	6.97	33.6	7.06	33.6	7.14	32.9	7.10
	5.0	4.1	35.5	6.80	35.4	6.95	35.4	7.10	35.3	7.18	35.3	7.26	32.9	6.67
	7.0	6.0	37.3	6.93	37.3	7.08	37.2	7.23	36.6	7.13	35.4	6.84	32.9	6.27
9.0	7.9	39.2	7.07	39.1	7.21	37.8	6.97	36.6	6.70	35.4	6.43	32.9	5.90	
11.0	9.8	41.2	7.20	40.2	7.07	37.8	6.56	36.6	6.30	35.4	6.05	32.9	5.56	
13.0	11.8	42.7	7.13	40.2	6.63	37.8	6.15	36.6	5.92	35.4	5.69	32.9	5.23	
15.0	13.7	42.7	6.71	40.2	6.25	37.8	5.80	36.6	5.58	35.4	5.36	32.9	4.94	
110%	-19.8	-20.0	20.2	5.00	20.1	5.25	20.0	5.50	20.0	5.62	20.0	5.75	19.9	6.00
	-18.8	-19.0	20.5	5.08	20.4	5.32	20.4	5.57	20.4	5.69	20.3	5.82	20.3	6.06
	-16.7	-17.0	21.3	5.25	21.2	5.48	21.5	5.72	21.1	5.84	21.1	5.96	21.0	6.19
	-13.7	-15.0	22.2	5.42	22.1	5.65	22.0	5.88	22.0	5.99	22.0	6.11	21.9	6.33
	-11.8	-13.0	23.1	5.61	23.1	5.82	23.0	6.04	23.0	6.15	22.9	6.26	22.9	6.48
	-9.8	-11.0	24.2	5.79	24.1	5.99	24.1	6.20	24.0	6.31	24.0	6.41	24.0	6.62
	-9.5	-10.0	24.8	5.88	24.7	6.08	24.6	6.29	24.6	6.39	24.6	6.49	24.5	6.69
	-8.5	-9.1	25.3	5.96	25.2	6.16	25.2	6.36	25.1	6.46	25.1	6.56	25.1	5.98
	-7.0	-7.6	26.2	6.09	26.2	6.28	26.1	6.47	26.1	6.57	26.1	6.67	26.0	6.86
	-5.0	-5.6	27.6	6.26	27.5	6.45	27.4	6.63	27.4	6.72	27.4	6.81	27.3	7.00
	-3.0	-3.7	28.9	6.43	28.9	6.60	28.8	6.77	28.8	6.86	28.7	6.94	28.7	7.12
	0.0	-0.7	31.2	6.67	31.2	6.83	31.1	6.99	31.1	7.07	31.1	7.15	30.2	7.01
	3.0	2.2	33.7	6.89	33.6	7.04	33.6	7.18	33.5	7.25	32.4	6.96	30.2	6.38
	5.0	4.1	35.4	7.02	35.4	7.17	34.7	7.10	33.5	6.81	32.4	6.54	30.2	6.00
	7.0	6.0	37.2	7.15	36.9	7.20	34.7	6.67	33.5	6.40	32.4	6.15	30.2	5.65
9.0	7.9	39.1	7.27	36.9	6.77	34.7	6.27	33.5	6.02	32.4	5.79	30.2	5.32	
11.0	9.8	39.1	6.84	36.9	6.36	34.7	5.90	33.5	5.68	32.4	5.45	30.2	5.02	
13.0	11.8	39.1	6.41	36.9	5.97	34.7	5.55	33.5	5.34	32.4	5.13	30.2	4.73	
15.0	13.7	39.1	5.69	36.9	5.63	34.7	5.24	33.5	5.04	32.4	4.85	30.2	4.47	

Abbreviations:

CR: Combination ratio

TC: Total capacity (kW)

PI: Power input (compressor + outdoor fan motor) (kW)

Notes:

1. Shaded cells indicate rating condition.

Table continued on next page ...

# VMEX 460V 60Hz

Table 2-8.10: VMEX009Q8A-D16V280 heating capacity (continued)

CR	Outdoor air temp.		Indoor air temp. °C DB											
			16.0		18.0		20.0		21.0		22.0		24.0	
	°C DB	°C WB	TC	PI	TC	PI	TC	PI	TC	PI	TC	PI	TC	PI
100%	-19.8	-20.0	20.1	5.40	20.0	5.62	20.0	5.86	19.9	5.97	19.9	6.08	19.8	6.31
	-18.8	-19.0	20.4	5.47	20.4	5.69	20.3	5.92	20.3	6.03	20.2	6.15	20.2	6.37
	-16.7	-17.0	21.2	5.62	21.1	5.84	21.1	6.06	21.0	6.16	21.0	6.27	21.0	6.49
	-13.7	-15.0	22.1	5.79	22.0	5.99	21.9	6.20	21.9	6.31	21.9	6.41	21.8	6.62
	-11.8	-13.0	23.0	5.96	23.0	6.15	22.9	6.35	22.9	6.45	22.9	6.55	22.8	6.75
	-9.8	-11.0	24.1	6.12	24.0	6.31	24.0	6.50	24.0	6.60	23.9	6.69	23.9	6.87
	-9.5	-10.0	24.7	6.20	24.6	6.39	24.6	6.57	24.5	6.67	24.5	6.76	24.4	6.94
	-8.5	-9.1	25.2	6.27	25.1	6.46	25.1	6.63	25.1	6.73	25.0	6.82	25.0	7.00
	-7.0	-7.6	26.1	6.40	26.1	6.57	26.0	6.74	26.0	6.83	26.0	6.92	25.9	7.10
	-5.0	-5.6	27.5	6.56	27.4	6.72	27.4	6.89	27.3	6.97	27.3	7.05	27.2	7.22
	-3.0	-3.7	28.8	6.70	28.8	6.09	28.7	7.02	28.7	7.10	28.7	7.17	27.5	6.87
	0.0	-0.7	31.1	6.92	31.1	7.07	31.0	7.21	30.5	7.10	29.5	6.80	27.5	6.24
	3.0	2.2	33.6	7.12	33.5	7.25	31.5	6.71	30.5	6.45	29.5	6.19	27.5	5.69
	5.0	4.1	35.3	7.25	33.5	6.81	31.5	6.31	30.5	6.07	29.5	5.83	27.5	5.36
	7.0	6.0	35.5	6.88	33.5	6.40	<b>31.5</b>	<b>5.94</b>	30.5	5.72	29.5	5.49	27.5	5.05
	9.0	7.9	35.5	6.46	33.5	6.02	31.5	5.59	30.5	5.32	29.5	5.18	27.5	4.77
11.0	9.8	35.5	6.09	33.5	5.68	31.5	5.28	30.5	5.08	29.5	4.88	27.5	4.50	
13.0	11.8	35.5	5.72	33.5	5.34	31.5	4.97	30.5	4.78	29.5	4.61	27.5	4.25	
15.0	13.7	35.5	5.39	33.5	5.04	31.5	4.69	30.5	4.52	29.5	4.35	27.5	4.03	
90%	-19.8	-20.0	20.0	5.80	19.9	6.00	19.9	6.21	19.8	6.31	19.8	6.42	19.8	6.62
	-18.8	-19.0	20.3	5.86	20.3	6.07	20.2	6.27	20.2	6.37	20.2	6.47	20.1	6.67
	-16.7	-17.0	21.1	6.01	21.0	6.20	21.0	6.39	21.0	6.50	20.9	6.59	20.9	6.78
	-13.7	-15.0	22.0	6.16	21.9	6.34	21.9	6.53	21.8	6.62	21.8	6.71	21.8	6.90
	-11.8	-13.0	22.9	6.30	22.9	6.48	22.8	6.66	22.8	6.75	22.8	6.83	22.7	7.01
	-9.8	-11.0	24.0	6.45	24.0	6.62	23.9	6.79	23.9	6.87	23.9	6.97	23.8	7.14
	-9.5	-10.0	24.6	6.53	24.5	6.70	24.5	6.86	24.4	6.94	24.4	7.03	24.4	7.19
	-8.5	-9.1	25.1	6.60	25.1	6.76	25.0	6.92	25.0	7.00	25.0	7.08	24.7	7.15
	-7.0	-7.6	26.0	6.70	26.0	6.86	25.9	7.02	25.9	7.10	25.9	7.17	24.7	6.83
	-5.0	-5.6	27.4	6.85	27.3	7.00	27.3	7.14	27.2	7.22	26.5	7.00	24.7	6.42
	-3.0	-3.7	28.7	6.98	28.7	7.12	28.4	7.15	27.4	6.87	26.5	6.59	24.7	6.05
	0.0	-0.7	31.0	7.18	30.1	7.00	28.4	6.49	27.4	6.23	26.5	5.99	24.7	5.50
	3.0	2.2	31.9	6.84	30.1	6.37	28.4	5.91	27.4	5.69	26.5	5.46	24.7	5.03
	5.0	4.1	31.9	6.43	30.1	5.99	28.4	5.57	27.4	5.35	26.5	5.15	24.7	4.74
	7.0	6.0	31.9	6.05	30.1	5.65	28.4	5.25	27.4	5.05	26.5	4.86	24.7	4.48
	9.0	7.9	31.9	5.70	30.1	5.31	28.4	4.94	27.4	4.77	26.5	4.59	24.7	4.24
11.0	9.8	31.9	5.37	30.1	5.01	28.4	4.67	27.4	4.50	26.5	4.34	24.7	4.01	
13.0	11.8	31.9	5.05	30.1	4.73	28.4	4.40	27.4	4.25	26.5	4.10	24.7	3.79	
15.0	13.7	31.9	4.78	30.1	4.47	28.4	4.17	27.4	4.03	26.5	3.88	24.7	3.59	
80%	-19.8	-20.0	19.9	6.20	19.8	6.38	19.8	6.56	19.8	6.66	19.7	6.75	19.7	6.93
	-18.8	-19.0	20.2	6.26	20.2	6.44	20.1	6.62	20.1	6.71	20.1	6.80	20.0	6.98
	-16.7	-17.0	21.0	6.39	20.9	6.56	20.9	6.73	20.9	6.82	20.9	6.90	20.8	7.07
	-13.7	-15.0	21.9	6.52	21.8	6.68	21.8	6.85	21.8	6.93	21.7	7.01	21.7	7.18
	-11.8	-13.0	22.8	6.65	22.8	6.81	22.7	6.97	22.7	7.04	22.7	7.13	22.0	6.94
	-9.8	-11.0	23.9	6.78	23.9	6.94	23.8	7.09	23.8	7.16	23.6	7.14	22.0	6.55
	-9.5	-10.0	24.5	6.85	24.4	7.00	24.4	7.14	24.4	7.22	23.6	6.94	22.0	6.36
	-8.5	-9.1	25.0	6.91	23.2	7.06	24.9	7.20	24.4	7.04	23.6	6.75	22.0	6.19
	-7.0	-7.6	25.9	7.01	25.9	7.15	25.2	7.00	24.4	6.72	23.6	6.45	22.0	5.92
	-5.0	-5.6	27.3	7.14	26.8	7.10	25.2	6.57	24.4	6.32	23.6	6.06	22.0	5.57
	-3.0	-3.7	28.4	7.17	26.8	6.68	25.2	6.19	24.4	5.96	23.6	5.72	22.0	5.26
	0.0	-0.7	28.4	6.51	26.8	6.06	25.2	5.63	24.4	5.42	23.6	5.21	22.0	4.80
	3.0	2.2	28.4	5.93	26.8	5.53	25.2	5.15	24.4	4.95	23.6	4.77	22.0	4.40
	5.0	4.1	28.4	5.59	26.8	5.21	25.2	4.85	24.4	4.67	23.6	4.51	22.0	4.16
	7.0	6.0	28.4	5.26	26.8	4.92	25.2	4.58	24.4	4.42	23.6	4.26	22.0	3.93
	9.0	7.9	28.4	4.97	26.8	4.64	25.2	4.33	24.4	4.17	23.6	4.03	22.0	3.73
11.0	9.8	28.4	4.69	26.8	4.39	25.2	4.10	24.4	3.95	23.6	3.81	22.0	3.53	
13.0	11.8	28.4	4.42	26.8	4.14	25.2	3.87	24.4	3.73	23.6	3.60	22.0	3.34	
15.0	13.7	28.4	4.18	26.8	3.93	25.2	3.67	24.4	3.54	23.6	3.42	22.0	3.18	

Abbreviations:

CR: Combination ratio

TC: Total capacity (kW)

PI: Power input (compressor + outdoor fan motor) (kW)

Notes:

1. Shaded cells indicate rating condition.

Table continued on next page ...



Table 2-8.10: VMEX009Q8A-D16V280

CR	Outdoor air temp.		Indoor air temp. °C DB											
			16.0		18.0		20.0		21.0		22.0		24.0	
	°C DB	°C WB	TC	PI	TC	PI	TC	PI	TC	PI	TC	PI	TC	PI
70%	-19.8	-20.0	19.8	6.60	19.7	6.76	19.7	6.92	19.7	7.00	19.7	7.08	19.2	7.00
	-18.8	-19.0	20.1	6.66	20.1	6.81	20.0	6.97	20.0	7.04	20.0	7.13	19.2	6.86
	-16.7	-17.0	20.9	6.77	20.9	6.92	20.8	7.07	20.8	7.14	20.6	6.36	19.2	6.54
	-13.7	-15.0	21.8	6.88	21.7	7.03	21.7	7.17	21.3	7.07	20.6	6.78	19.2	6.22
	-11.8	-13.0	22.6	7.00	22.6	7.14	22.1	6.97	21.3	6.70	20.6	6.43	19.2	5.89
	-9.8	-11.0	23.7	7.11	23.4	7.10	22.1	6.58	21.3	6.33	20.6	6.07	19.2	5.58
	-9.5	-10.0	24.3	7.17	23.4	6.90	22.1	6.39	21.3	6.14	20.6	5.90	19.2	5.42
	-8.5	-9.1	24.8	7.21	23.4	6.71	22.1	6.22	21.3	5.98	20.6	5.75	19.2	5.28
	-7.0	-7.6	24.8	6.89	23.4	6.41	22.1	5.95	21.3	5.72	20.6	5.50	19.2	5.06
	-5.0	-5.6	24.8	6.47	23.4	6.03	22.1	5.60	21.3	5.38	20.6	6.36	19.2	4.77
	-3.0	-3.7	24.8	6.09	23.4	5.69	22.1	5.28	21.3	5.08	20.6	4.89	19.2	4.51
	0.0	-0.7	24.8	5.55	23.4	5.18	22.1	4.82	21.3	4.64	20.6	4.47	19.2	4.13
	3.0	2.2	24.8	5.07	23.4	4.74	22.1	4.42	21.3	4.26	20.6	4.10	19.2	3.80
	5.0	4.1	24.8	4.78	23.4	4.47	22.1	4.18	21.3	4.03	20.6	3.88	19.2	3.59
	7.0	6.0	24.8	4.52	23.4	4.24	22.1	3.95	21.3	3.81	20.6	3.68	19.2	3.41
9.0	7.9	24.8	4.27	23.4	4.00	22.1	3.74	21.3	3.61	20.6	3.49	19.2	3.23	
11.0	9.8	24.8	4.04	23.4	3.79	22.1	3.55	21.3	3.43	20.6	3.31	19.2	3.07	
13.0	11.8	24.8	3.82	23.4	3.59	22.1	3.36	21.3	3.25	20.6	3.13	19.2	2.92	
15.0	13.7	24.8	3.62	23.4	3.40	22.1	3.19	21.3	3.09	20.6	2.98	19.2	2.78	
60%	-19.8	-20.0	19.7	7.00	19.6	7.14	18.9	6.87	18.3	6.60	17.7	6.33	16.5	5.81
	-18.8	-19.0	20.0	7.05	20.0	7.18	18.9	6.72	18.3	6.46	17.7	6.19	16.5	5.69
	-16.7	-17.0	20.8	7.14	20.1	6.92	18.9	6.41	18.3	6.16	17.7	5.92	16.5	5.44
	-13.7	-15.0	21.3	7.07	20.1	6.57	18.9	6.09	18.3	5.86	17.7	5.63	16.5	5.18
	-11.8	-13.0	21.3	6.69	20.1	6.22	18.9	5.78	18.3	5.56	17.7	5.35	16.5	4.94
	-9.8	-11.0	21.3	6.32	20.1	5.89	18.9	5.47	18.3	5.26	17.7	5.06	16.5	4.67
	-9.5	-10.0	21.3	6.14	20.1	5.72	18.9	5.31	18.3	5.12	17.7	4.92	16.5	4.54
	-8.5	-9.1	21.3	5.98	20.1	5.58	18.9	5.18	18.3	4.99	17.7	4.80	16.5	4.43
	-7.0	-7.6	21.3	5.72	20.1	5.34	18.9	4.96	18.3	4.78	17.7	4.60	16.5	4.25
	-5.0	-5.6	21.3	5.38	20.1	5.03	18.9	4.68	18.3	4.51	17.7	4.34	16.5	4.02
	-3.0	-3.7	21.3	5.08	20.1	4.75	18.9	4.43	18.3	4.27	17.7	4.11	16.5	3.80
	0.0	-0.7	21.3	4.64	20.1	4.35	18.9	4.06	18.3	3.92	17.7	3.77	16.5	3.49
	3.0	2.2	21.3	4.26	20.1	4.00	18.9	3.73	18.3	3.60	17.7	3.48	16.5	3.22
	5.0	4.1	21.3	4.03	20.1	3.78	18.9	3.53	18.3	3.42	17.7	3.29	16.5	3.06
	7.0	6.0	21.3	3.81	20.1	3.58	18.9	3.35	18.3	3.24	17.7	3.13	16.5	2.91
9.0	7.9	21.3	3.61	20.1	3.39	18.9	3.18	18.3	3.08	17.7	2.97	16.5	2.77	
11.0	9.8	21.3	3.42	20.1	3.22	18.9	3.02	18.3	2.92	17.7	2.82	16.5	2.64	
13.0	11.8	21.3	3.24	20.1	3.05	18.9	2.87	18.3	2.78	17.7	2.68	16.5	2.51	
15.0	13.7	21.3	3.09	20.1	2.90	18.9	2.73	18.3	2.65	17.7	2.56	16.5	2.39	
50%	-19.8	-20.0	17.7	6.37	16.7	5.93	15.8	5.51	15.2	5.31	14.7	5.10	13.7	4.70
	-18.8	-19.0	17.7	6.23	16.7	5.81	15.8	5.40	15.2	5.19	14.7	4.99	13.7	4.61
	-16.7	-17.0	17.7	5.95	16.7	5.55	15.8	5.16	15.2	4.97	14.7	4.78	13.7	4.41
	-13.7	-15.0	17.7	5.66	16.7	5.28	15.8	4.91	15.2	4.74	14.7	4.56	13.7	4.21
	-11.8	-13.0	17.7	5.38	16.7	5.02	15.8	4.67	15.2	4.50	14.7	4.34	13.7	4.01
	-9.8	-11.0	17.7	5.09	16.7	4.76	15.8	4.44	15.2	4.27	14.7	4.12	13.7	3.81
	-9.5	-10.0	17.7	4.95	16.7	4.63	15.8	4.32	15.2	4.17	14.7	4.01	13.7	3.71
	-8.5	-9.1	17.7	4.83	16.7	4.52	15.8	4.21	15.2	4.07	14.7	3.92	13.7	3.63
	-7.0	-7.6	17.7	4.63	16.7	4.34	15.8	4.04	15.2	3.90	14.7	3.76	13.7	3.49
	-5.0	-5.6	17.7	4.37	16.7	4.10	15.8	3.83	15.2	3.69	14.7	3.56	13.7	3.30
	-3.0	-3.7	17.7	4.13	16.7	3.88	15.8	3.63	15.2	3.50	14.7	3.38	13.7	3.14
	0.0	-0.7	17.7	3.80	16.7	3.56	15.8	3.34	15.2	3.22	14.7	3.12	13.7	2.90
	3.0	2.2	17.7	3.49	16.7	3.29	15.8	3.08	15.2	2.98	14.7	2.88	13.7	2.68
	5.0	4.1	17.7	3.32	16.7	3.12	15.8	2.92	15.2	2.83	14.7	2.74	13.7	2.55
	7.0	6.0	17.7	3.15	16.7	2.96	15.8	2.78	15.2	2.69	14.7	2.61	13.7	2.44
9.0	7.9	17.7	2.99	16.7	2.82	15.8	2.65	15.2	2.57	14.7	2.48	13.7	2.32	
11.0	9.8	17.7	2.84	16.7	2.68	15.8	2.52	15.2	2.45	14.7	2.37	13.7	2.21	
13.0	11.8	17.7	2.70	16.7	2.55	15.8	2.40	15.2	2.33	14.7	2.25	13.7	2.11	
15.0	13.7	17.7	2.57	16.7	2.43	15.8	2.29	15.2	2.22	14.7	2.15	13.7	2.02	

Abbreviations:

CR: Combination ratio

TC: Total capacity (kW)

PI: Power input (compressor + outdoor fan motor) (kW)

Notes:

1. Shaded cells indicate rating condition.

# VMEX 460V 60Hz

Table 2-8.11: VMEX010Q8A-D20V335 heating capacity

CR	Outdoor air temp.		Indoor air temp. °C DB											
			16.0		18.0		20.0		21.0		22.0		24.0	
	°C DB	°C WB	TC	PI	TC	PI	TC	PI	TC	PI	TC	PI	TC	PI
130%	-19.8	-20.0	24.3	5.40	24.2	5.78	24.0	6.17	24.0	6.36	23.9	6.55	23.9	6.93
	-18.8	-19.0	24.6	5.52	24.5	5.90	24.5	6.28	24.4	6.47	24.4	6.65	24.3	7.02
	-16.7	-17.0	25.6	5.78	25.5	6.14	25.4	6.51	25.4	6.69	25.4	6.86	25.2	7.22
	-13.7	-15.0	26.7	6.05	26.5	6.40	26.4	6.75	26.4	6.91	26.3	7.09	26.3	7.44
	-11.8	-13.0	27.7	6.32	27.7	6.66	27.6	6.98	27.5	7.15	27.5	7.32	27.4	7.65
	-9.8	-11.0	29.0	6.60	28.9	6.91	28.8	7.23	28.8	7.39	28.8	7.55	28.7	7.87
	-9.5	-10.0	29.8	6.74	29.6	7.04	29.5	7.35	29.5	7.51	29.4	7.66	29.4	7.97
	-8.5	-9.1	30.4	6.86	30.2	7.15	30.2	7.46	30.1	7.61	30.1	7.76	30.0	8.07
	-7.0	-7.6	31.4	7.05	31.4	7.35	31.3	7.64	31.3	7.79	31.2	7.93	31.1	8.23
	-5.0	-5.6	33.1	7.32	33.0	7.60	32.9	7.88	32.9	8.02	32.7	8.15	32.7	8.42
	-3.0	-3.7	34.6	7.56	34.5	7.83	34.5	8.09	34.4	8.23	34.4	8.35	34.3	8.61
	0.0	-0.7	37.4	7.93	37.4	8.18	37.3	8.41	37.3	8.50	37.1	8.66	37.1	8.90
	3.0	2.2	40.4	8.26	40.2	8.48	40.1	8.71	40.1	8.82	40.1	8.94	40.0	9.16
	5.0	4.1	42.4	8.46	42.3	8.68	42.3	8.89	42.1	9.00	42.1	9.11	42.0	9.32
	7.0	6.0	44.5	8.66	44.4	8.86	44.4	9.07	44.3	9.17	44.3	9.27	42.5	8.90
9.0	7.9	46.8	8.84	46.7	9.04	46.7	9.23	46.5	9.33	45.6	9.13	42.5	8.36	
11.0	9.8	49.2	9.02	49.0	9.20	48.8	9.32	47.1	8.95	45.6	8.58	42.5	7.88	
13.0	11.8	51.8	9.19	51.7	9.37	48.8	8.73	47.1	8.38	45.6	8.06	42.5	7.39	
15.0	13.7	54.3	9.35	51.9	8.87	48.8	8.23	47.1	7.91	45.6	7.59	42.5	6.97	
120%	-19.8	-20.0	24.2	5.92	24.0	6.27	23.9	6.63	23.9	6.80	23.9	6.97	23.8	7.33
	-18.8	-19.0	24.5	6.03	24.4	6.38	24.4	6.73	24.3	6.90	24.3	7.07	24.2	7.42
	-16.7	-17.0	25.5	6.27	25.4	6.61	25.2	6.93	25.2	7.10	25.2	7.27	25.1	7.60
	-13.7	-15.0	26.6	6.52	26.4	6.84	26.3	7.15	26.3	7.32	26.3	7.48	26.2	7.80
	-11.8	-13.0	27.6	6.77	27.6	7.07	27.5	7.38	27.5	7.54	27.4	7.69	27.4	8.00
	-9.8	-11.0	28.9	7.02	28.8	7.31	28.8	7.61	28.7	7.76	28.7	7.90	28.6	8.20
	-9.5	-10.0	29.6	7.15	29.5	7.44	29.4	7.72	29.4	7.87	29.4	8.01	29.3	8.30
	-8.5	-9.1	30.2	7.26	30.1	7.54	30.1	7.82	30.0	7.96	30.0	8.11	29.9	8.38
	-7.0	-7.6	31.3	7.45	31.3	7.72	31.2	7.99	31.2	8.13	31.1	8.26	31.1	8.52
	-5.0	-5.6	33.0	7.69	32.9	7.95	32.7	8.21	32.7	8.34	32.7	8.46	32.6	8.71
	-3.0	-3.7	34.5	7.92	34.5	8.17	34.4	8.41	34.4	8.52	34.3	8.65	34.3	8.89
	0.0	-0.7	37.3	8.26	37.3	8.48	37.1	8.70	37.1	8.82	37.0	8.93	37.0	9.16
	3.0	2.2	40.2	8.56	40.1	8.77	40.1	8.98	40.0	9.09	40.0	9.19	39.2	9.14
	5.0	4.1	42.3	8.75	42.1	8.95	42.1	9.15	42.0	9.25	42.0	9.35	39.2	8.58
	7.0	6.0	44.4	8.93	44.4	9.12	44.3	9.31	43.6	9.18	42.1	8.80	39.2	8.08
9.0	7.9	46.7	9.11	46.6	9.29	45.0	8.98	43.6	8.63	42.1	8.28	39.2	7.60	
11.0	9.8	49.0	9.27	47.9	9.11	45.0	8.45	43.6	8.12	42.1	7.79	39.2	7.16	
13.0	11.8	50.8	9.18	47.9	8.54	45.0	7.92	43.6	7.62	42.1	7.32	39.2	6.74	
15.0	13.7	50.8	8.64	47.9	8.05	45.0	7.47	43.6	7.18	42.1	6.90	39.2	6.36	
110%	-19.8	-20.0	24.0	6.44	23.9	6.76	23.8	7.08	23.8	7.24	23.8	7.40	23.7	7.73
	-18.8	-19.0	24.4	6.54	24.3	6.86	24.3	7.17	24.3	7.33	24.2	7.49	24.2	7.81
	-16.7	-17.0	25.4	6.76	25.2	7.06	25.6	7.37	25.1	7.52	25.1	7.68	25.0	7.98
	-13.7	-15.0	26.4	6.98	26.3	7.28	26.2	7.57	26.2	7.72	26.2	7.87	26.1	8.16
	-11.8	-13.0	27.5	7.22	27.5	7.50	27.4	7.78	27.4	7.92	27.3	8.06	27.3	8.35
	-9.8	-11.0	28.8	7.45	28.7	7.72	28.7	7.99	28.6	8.13	28.6	8.26	28.6	8.52
	-9.5	-10.0	29.5	7.57	29.4	7.83	29.3	8.10	29.3	8.23	29.3	8.36	29.2	8.61
	-8.5	-9.1	30.1	7.67	30.0	7.93	30.0	8.19	29.9	8.32	29.9	8.45	29.9	7.70
	-7.0	-7.6	31.2	7.85	31.2	8.09	31.1	8.34	31.1	8.46	31.1	8.58	31.0	8.83
	-5.0	-5.6	32.9	8.07	32.7	8.31	32.6	8.53	32.6	8.65	32.6	8.77	32.5	9.01
	-3.0	-3.7	34.4	8.28	34.4	8.49	34.3	8.72	34.3	8.83	34.2	8.94	34.2	9.17
	0.0	-0.7	37.1	8.58	37.1	8.79	37.0	9.00	37.0	9.10	37.0	9.21	36.0	9.03
	3.0	2.2	40.1	8.87	40.0	9.06	40.0	9.25	39.9	9.34	38.6	8.96	36.0	8.22
	5.0	4.1	42.1	9.04	42.1	9.23	41.3	9.14	39.9	8.77	38.6	8.43	36.0	7.73
	7.0	6.0	44.3	9.21	43.9	9.27	41.3	8.58	39.9	8.25	38.6	7.92	36.0	7.27
9.0	7.9	46.5	9.36	43.9	8.71	41.3	8.08	39.9	7.76	38.6	7.45	36.0	6.86	
11.0	9.8	46.5	8.80	43.9	8.20	41.3	7.60	39.9	7.31	38.6	7.02	36.0	6.47	
13.0	11.8	46.5	8.26	43.9	7.69	41.3	7.14	39.9	6.87	38.6	6.61	36.0	6.09	
15.0	13.7	46.5	7.33	43.9	7.25	41.3	6.75	39.9	6.49	38.6	6.25	36.0	5.76	

Abbreviations:

CR: Combination ratio

TC: Total capacity (kW)

PI: Power input (compressor + outdoor fan motor) (kW)

Notes:

1. Shaded cells indicate rating condition.

Table continued on next page ...

Table 2-8.11: VMEX010Q8A-D20V335 heating capacity (continued)

CR	Outdoor air temp.		Indoor air temp. °C DB											
			16.0		18.0		20.0		21.0		22.0		24.0	
	°C DB	°C WB	TC	PI	TC	PI	TC	PI	TC	PI	TC	PI	TC	PI
100%	-19.8	-20.0	23.9	6.95	23.8	7.24	23.8	7.54	23.7	7.69	23.7	7.83	23.6	8.13
	-18.8	-19.0	24.3	7.04	24.3	7.33	24.2	7.62	24.2	7.77	24.0	7.92	24.0	8.21
	-16.7	-17.0	25.2	7.24	25.1	7.52	25.1	7.80	25.0	7.94	25.0	8.08	25.0	8.36
	-13.7	-15.0	26.3	7.45	26.2	7.72	26.1	7.99	26.1	8.13	26.1	8.26	26.0	8.52
	-11.8	-13.0	27.4	7.67	27.4	7.92	27.3	8.18	27.3	8.31	27.3	8.43	27.1	8.69
	-9.8	-11.0	28.7	7.88	28.6	8.13	28.6	8.37	28.6	8.49	28.5	8.61	28.5	8.85
	-9.5	-10.0	29.4	7.99	29.3	8.23	29.3	8.46	29.2	8.58	29.2	8.70	29.0	8.94
	-8.5	-9.1	30.0	8.08	29.9	8.32	29.9	8.54	29.9	8.66	29.8	8.78	29.8	9.01
	-7.0	-7.6	31.1	8.24	31.1	8.46	31.0	8.68	31.0	8.80	31.0	8.91	30.8	9.14
	-5.0	-5.6	32.7	8.44	32.6	8.65	32.6	8.87	32.5	8.97	32.5	9.08	32.4	9.30
	-3.0	-3.7	34.3	8.63	34.3	7.84	34.2	9.04	34.2	9.14	34.2	9.24	32.7	8.85
	0.0	-0.7	37.0	8.91	37.0	9.10	36.9	9.29	36.3	9.14	35.1	8.76	32.7	8.04
	3.0	2.2	40.0	9.17	39.9	9.34	37.5	8.64	36.3	8.31	35.1	7.98	32.7	7.32
	5.0	4.1	42.0	9.34	39.9	8.77	37.5	8.13	36.3	7.82	35.1	7.51	32.7	6.90
	7.0	6.0	42.3	8.86	39.9	8.25	<b>37.5</b>	<b>7.65</b>	36.3	7.36	35.1	7.07	32.7	6.51
9.0	7.9	42.3	8.33	39.9	7.76	37.5	7.20	36.3	6.85	35.1	6.67	32.7	6.14	
11.0	9.8	42.3	7.84	39.9	7.31	37.5	6.80	36.3	6.54	35.1	6.29	32.7	5.80	
13.0	11.8	42.3	7.36	39.9	6.88	37.5	6.40	36.3	6.16	35.1	5.93	32.7	5.47	
15.0	13.7	42.3	6.94	39.9	6.49	37.5	6.04	36.3	5.82	35.1	5.60	32.7	5.19	
90%	-19.8	-20.0	23.8	7.47	23.6	7.73	23.6	8.00	23.5	8.13	23.5	8.27	23.5	8.52
	-18.8	-19.0	24.1	7.55	24.1	7.82	24.0	8.08	24.0	8.21	24.0	8.34	23.9	8.59
	-16.7	-17.0	25.1	7.74	25.0	7.99	25.0	8.24	25.0	8.36	24.8	8.48	24.8	8.73
	-13.7	-15.0	26.1	7.93	26.0	8.17	26.0	8.40	25.9	8.52	25.9	8.64	25.9	8.88
	-11.8	-13.0	27.2	8.12	27.2	8.35	27.1	8.57	27.1	8.69	27.1	8.80	27.0	9.03
	-9.8	-11.0	28.5	8.31	28.5	8.52	28.4	8.74	28.4	8.85	28.4	8.97	28.3	9.19
	-9.5	-10.0	29.2	8.40	29.1	8.62	29.1	8.83	29.0	8.94	29.0	9.05	29.0	9.26
	-8.5	-9.1	29.8	8.49	29.8	8.70	29.7	8.91	29.7	9.01	29.7	9.12	29.4	9.21
	-7.0	-7.6	30.9	8.63	30.9	8.83	30.8	9.04	30.8	9.14	30.8	9.24	29.4	8.79
	-5.0	-5.6	32.6	8.82	32.4	9.01	32.4	9.20	32.3	9.30	31.5	9.01	29.4	8.27
	-3.0	-3.7	34.1	8.99	34.1	9.17	33.8	9.21	32.6	8.84	31.5	8.48	29.4	7.79
	0.0	-0.7	37.0	9.25	35.9	9.02	33.8	8.36	32.6	8.03	31.5	7.71	29.4	7.08
	3.0	2.2	38.0	8.81	35.9	8.21	33.8	7.61	32.6	7.32	31.5	7.03	29.4	6.48
	5.0	4.1	38.0	8.29	35.9	7.72	33.8	7.17	32.6	6.89	31.5	6.64	29.4	6.11
	7.0	6.0	38.0	7.79	35.9	7.27	33.8	6.76	32.6	6.51	31.5	6.26	29.4	5.77
9.0	7.9	38.0	7.34	35.9	6.84	33.8	6.37	32.6	6.14	31.5	5.91	29.4	5.45	
11.0	9.8	38.0	6.91	35.9	6.46	33.8	6.02	32.6	5.80	31.5	5.58	29.4	5.17	
13.0	11.8	38.0	6.51	35.9	6.09	33.8	5.67	32.6	5.47	31.5	5.28	29.4	4.88	
15.0	13.7	38.0	6.15	35.9	5.75	33.8	5.37	32.6	5.19	31.5	5.00	29.4	4.63	
80%	-19.8	-20.0	23.7	7.99	23.6	8.22	23.6	8.45	23.6	8.57	23.5	8.69	23.5	8.92
	-18.8	-19.0	24.0	8.06	24.0	8.30	23.9	8.52	23.9	8.64	23.9	8.75	23.8	8.99
	-16.7	-17.0	25.0	8.23	24.9	8.44	24.9	8.67	24.9	8.78	24.9	8.89	24.8	9.11
	-13.7	-15.0	26.1	8.40	26.0	8.60	26.0	8.82	26.0	8.92	25.8	9.03	25.8	9.25
	-11.8	-13.0	27.1	8.56	27.1	8.77	27.0	8.97	27.0	9.07	27.0	9.18	26.2	8.93
	-9.8	-11.0	28.5	8.73	28.5	8.93	28.3	9.13	28.3	9.22	28.1	9.20	26.2	8.43
	-9.5	-10.0	29.2	8.82	29.0	9.01	29.0	9.20	29.0	9.30	28.1	8.93	26.2	8.19
	-8.5	-9.1	29.8	8.90	27.7	9.09	29.6	9.27	29.0	9.06	28.1	8.69	26.2	7.97
	-7.0	-7.6	30.8	9.03	30.8	9.21	30.0	9.01	29.0	8.65	28.1	8.31	26.2	7.62
	-5.0	-5.6	32.5	9.19	31.9	9.14	30.0	8.46	29.0	8.14	28.1	7.81	26.2	7.17
	-3.0	-3.7	33.8	9.24	31.9	8.60	30.0	7.97	29.0	7.67	28.1	7.36	26.2	6.78
	0.0	-0.7	33.8	8.39	31.9	7.81	30.0	7.25	29.0	6.98	28.1	6.71	26.2	6.18
	3.0	2.2	33.8	7.64	31.9	7.12	30.0	6.63	29.0	6.38	28.1	6.14	26.2	5.66
	5.0	4.1	33.8	7.19	31.9	6.72	30.0	6.25	29.0	6.02	28.1	5.80	26.2	5.35
	7.0	6.0	33.8	6.78	31.9	6.34	30.0	5.90	29.0	5.69	28.1	5.48	26.2	5.07
9.0	7.9	33.8	6.40	31.9	5.98	30.0	5.57	29.0	5.37	28.1	5.19	26.2	4.80	
11.0	9.8	33.8	6.04	31.9	5.65	30.0	5.28	29.0	5.09	28.1	4.91	26.2	4.55	
13.0	11.8	33.8	5.69	31.9	5.33	30.0	4.99	29.0	4.81	28.1	4.64	26.2	4.30	
15.0	13.7	33.8	5.38	31.9	5.06	30.0	4.73	29.0	4.56	28.1	4.40	26.2	4.09	

Abbreviations:

CR: Combination ratio

TC: Total capacity (kW)

PI: Power input (compressor + outdoor fan motor) (kW)

Notes:

1. Shaded cells indicate rating condition.

Table continued on next page ...

# VMEX 460V 60Hz

Table 2-8.11: VMEX010Q8A-D20V335 heating capacity (continued)

CR	Outdoor air temp.		Indoor air temp. °C DB											
			16.0		18.0		20.0		21.0		22.0		24.0	
	°C DB	°C WB	TC	PI	TC	PI	TC	PI	TC	PI	TC	PI	TC	PI
70%	-19.8	-20.0	23.5	8.50	23.4	8.70	23.4	8.91	23.4	9.01	23.4	9.12	22.8	9.02
	-18.8	-19.0	23.9	8.57	23.9	8.77	23.8	8.97	23.8	9.07	23.8	9.18	22.8	8.83
	-16.7	-17.0	24.8	8.71	24.8	8.91	24.7	9.10	24.7	9.20	24.5	8.20	22.8	8.42
	-13.7	-15.0	25.9	8.86	25.8	9.05	25.8	9.24	25.3	9.10	24.5	8.73	22.8	8.01
	-11.8	-13.0	27.0	9.01	27.0	9.19	26.3	8.97	25.3	8.62	24.5	8.28	22.8	7.59
	-9.8	-11.0	28.3	9.16	27.9	9.15	26.3	8.47	25.3	8.15	24.5	7.82	22.8	7.18
	-9.5	-10.0	29.0	9.24	27.9	8.88	26.3	8.23	25.3	7.91	24.5	7.60	22.8	6.98
	-8.5	-9.1	29.6	9.29	27.9	8.64	26.3	8.01	25.3	7.70	24.5	7.40	22.8	6.81
	-7.0	-7.6	29.6	8.87	27.9	8.26	26.3	7.66	25.3	7.37	24.5	7.08	22.8	6.52
	-5.0	-5.6	29.6	8.34	27.9	7.77	26.3	7.21	25.3	6.93	24.5	8.19	22.8	6.15
	-3.0	-3.7	29.6	7.85	27.9	7.32	26.3	6.81	25.3	6.55	24.5	6.30	22.8	5.81
	0.0	-0.7	29.6	7.14	27.9	6.68	26.3	6.21	25.3	5.98	24.5	5.76	22.8	5.33
	3.0	2.2	29.6	6.53	27.9	6.11	26.3	5.69	25.3	5.48	24.5	5.28	22.8	4.89
	5.0	4.1	29.6	6.16	27.9	5.76	26.3	5.38	25.3	5.19	24.5	5.00	22.8	4.63
	7.0	6.0	29.6	5.82	27.9	5.45	26.3	5.09	25.3	4.91	24.5	4.74	22.8	4.39
9.0	7.9	29.6	5.50	27.9	5.16	26.3	4.82	25.3	4.65	24.5	4.49	22.8	4.16	
11.0	9.8	29.6	5.21	27.9	4.88	26.3	4.57	25.3	4.41	24.5	4.26	22.8	3.95	
13.0	11.8	29.6	4.92	27.9	4.62	26.3	4.32	25.3	4.18	24.5	4.03	22.8	3.76	
15.0	13.7	29.6	4.66	27.9	4.38	26.3	4.10	25.3	3.97	24.5	3.83	22.8	3.58	
60%	-19.8	-20.0	23.5	9.02	23.3	9.19	22.5	8.84	21.8	8.49	21.1	8.16	19.6	7.48
	-18.8	-19.0	23.8	9.08	23.8	9.25	22.5	8.65	21.8	8.32	21.1	7.98	19.6	7.32
	-16.7	-17.0	24.8	9.20	23.9	8.91	22.5	8.26	21.8	7.94	21.1	7.62	19.6	7.00
	-13.7	-15.0	25.4	9.10	23.9	8.46	22.5	7.85	21.8	7.55	21.1	7.25	19.6	6.67
	-11.8	-13.0	25.4	8.61	23.9	8.02	22.5	7.44	21.8	7.16	21.1	6.88	19.6	6.37
	-9.8	-11.0	25.4	8.14	23.9	7.58	22.5	7.04	21.8	6.78	21.1	6.52	19.6	6.01
	-9.5	-10.0	25.4	7.91	23.9	7.37	22.5	6.85	21.8	6.60	21.1	6.34	19.6	5.84
	-8.5	-9.1	25.4	7.70	23.9	7.18	22.5	6.68	21.8	6.43	21.1	6.18	19.6	5.70
	-7.0	-7.6	25.4	7.36	23.9	6.87	22.5	6.39	21.8	6.16	21.1	5.92	19.6	5.47
	-5.0	-5.6	25.4	6.93	23.9	6.48	22.5	6.03	21.8	5.81	21.1	5.59	19.6	5.18
	-3.0	-3.7	25.4	6.55	23.9	6.12	22.5	5.70	21.8	5.50	21.1	5.30	19.6	4.90
	0.0	-0.7	25.4	5.98	23.9	5.60	22.5	5.23	21.8	5.05	21.1	4.86	19.6	4.50
	3.0	2.2	25.4	5.48	23.9	5.15	22.5	4.81	21.8	4.64	21.1	4.48	19.6	4.15
	5.0	4.1	25.4	5.19	23.9	4.87	22.5	4.55	21.8	4.40	21.1	4.24	19.6	3.94
	7.0	6.0	25.4	4.91	23.9	4.61	22.5	4.31	21.8	4.17	21.1	4.03	19.6	3.75
9.0	7.9	25.4	4.65	23.9	4.37	22.5	4.09	21.8	3.96	21.1	3.82	19.6	3.57	
11.0	9.8	25.4	4.41	23.9	4.15	22.5	3.89	21.8	3.77	21.1	3.64	19.6	3.40	
13.0	11.8	25.4	4.17	23.9	3.93	22.5	3.70	21.8	3.58	21.1	3.46	19.6	3.23	
15.0	13.7	25.4	3.97	23.9	3.74	22.5	3.52	21.8	3.41	21.1	3.30	19.6	3.08	
50%	-19.8	-20.0	21.1	8.21	19.9	7.64	18.8	7.09	18.0	6.83	17.4	6.57	16.3	6.05
	-18.8	-19.0	21.1	8.03	19.9	7.48	18.8	6.95	18.0	6.69	17.4	6.43	16.3	5.93
	-16.7	-17.0	21.1	7.66	19.9	7.14	18.8	6.65	18.0	6.40	17.4	6.16	16.3	5.68
	-13.7	-15.0	21.1	7.29	19.9	6.81	18.8	6.33	18.0	6.10	17.4	5.87	16.3	5.42
	-11.8	-13.0	21.1	6.92	19.9	6.47	18.8	6.02	18.0	5.80	17.4	5.58	16.3	5.17
	-9.8	-11.0	21.1	6.56	19.9	6.13	18.8	5.71	18.0	5.50	17.4	5.30	16.3	4.91
	-9.5	-10.0	21.1	6.38	19.9	5.96	18.8	5.56	18.0	5.36	17.4	5.17	16.3	4.78
	-8.5	-9.1	21.1	6.22	19.9	5.82	18.8	5.42	18.0	5.24	17.4	5.05	16.3	4.67
	-7.0	-7.6	21.1	5.96	19.9	5.58	18.8	5.21	18.0	5.03	17.4	4.85	16.3	4.49
	-5.0	-5.6	21.1	5.62	19.9	5.28	18.8	4.93	18.0	4.76	17.4	4.59	16.3	4.25
	-3.0	-3.7	21.1	5.32	19.9	5.00	18.8	4.67	18.0	4.51	17.4	4.35	16.3	4.04
	0.0	-0.7	21.1	4.89	19.9	4.59	18.8	4.30	18.0	4.15	17.4	4.01	16.3	3.74
	3.0	2.2	21.1	4.50	19.9	4.23	18.8	3.96	18.0	3.83	17.4	3.71	16.3	3.46
	5.0	4.1	21.1	4.27	19.9	4.01	18.8	3.77	18.0	3.65	17.4	3.53	16.3	3.29
	7.0	6.0	21.1	4.05	19.9	3.81	18.8	3.59	18.0	3.47	17.4	3.36	16.3	3.14
9.0	7.9	21.1	3.84	19.9	3.63	18.8	3.41	18.0	3.31	17.4	3.20	16.3	2.99	
11.0	9.8	21.1	3.66	19.9	3.45	18.8	3.25	18.0	3.15	17.4	3.05	16.3	2.85	
13.0	11.8	21.1	3.48	19.9	3.28	18.8	3.09	18.0	3.00	17.4	2.90	16.3	2.72	
15.0	13.7	21.1	3.31	19.9	3.13	18.8	2.95	18.0	2.86	17.4	2.77	16.3	2.60	

Abbreviations:

CR: Combination ratio

TC: Total capacity (kW)

PI: Power input (compressor + outdoor fan motor) (kW)

Notes:

1. Shaded cells indicate rating condition.

Table 2-8.12: VMEX012Q8A-D23V400 heating capacity

CR	Outdoor air temp.		Indoor air temp. °C DB											
			16.0		18.0		20.0		21.0		22.0		24.0	
	°C DB	°C WB	TC	PI	TC	PI	TC	PI	TC	PI	TC	PI	TC	PI
130%	-19.8	-20.0	29.1	6.63	29.0	7.09	28.9	7.57	28.9	7.80	28.7	8.03	28.7	8.50
	-18.8	-19.0	29.6	6.77	29.4	7.24	29.4	7.70	29.3	7.93	29.3	8.15	29.1	8.61
	-16.7	-17.0	30.7	7.09	30.6	7.53	30.4	7.98	30.4	8.20	30.4	8.42	30.3	8.86
	-13.7	-15.0	32.0	7.42	31.9	7.85	31.7	8.27	31.7	8.48	31.6	8.70	31.6	9.12
	-11.8	-13.0	33.3	7.75	33.3	8.16	33.1	8.56	33.0	8.77	33.0	8.98	32.9	9.38
	-9.8	-11.0	34.9	8.09	34.7	8.48	34.6	8.87	34.6	9.06	34.6	9.26	34.4	9.65
	-9.5	-10.0	35.7	8.26	35.6	8.64	35.4	9.01	35.4	9.21	35.3	9.39	35.3	9.77
	-8.5	-9.1	36.4	8.41	36.3	8.77	36.3	9.15	36.1	9.33	36.1	9.51	36.0	9.89
	-7.0	-7.6	37.7	8.65	37.7	9.01	37.6	9.37	37.6	9.55	37.4	9.72	37.3	10.09
	-5.0	-5.6	39.7	8.98	39.6	9.32	39.4	9.66	39.4	9.83	39.3	9.99	39.3	10.33
	-3.0	-3.7	41.6	9.27	41.4	9.60	41.4	9.92	41.3	10.09	41.3	10.24	41.1	10.56
	0.0	-0.7	44.9	9.72	44.9	10.03	44.7	10.32	44.7	10.43	44.6	10.62	44.6	10.91
	3.0	2.2	48.4	10.12	48.3	10.40	48.1	10.68	48.1	10.82	48.1	10.96	48.0	11.23
	5.0	4.1	50.9	10.38	50.7	10.65	50.7	10.90	50.6	11.04	50.6	11.17	50.4	11.43
	7.0	6.0	53.4	10.62	53.3	10.87	53.3	11.12	53.1	11.24	53.1	11.37	51.0	10.91
9.0	7.9	56.1	10.84	56.0	11.09	56.0	11.32	55.9	11.44	54.7	11.20	51.0	10.26	
11.0	9.8	59.0	11.06	58.9	11.28	58.6	11.43	56.6	10.98	54.7	10.52	51.0	9.66	
13.0	11.8	62.1	11.27	62.0	11.49	58.6	10.71	56.6	10.28	54.7	9.88	51.0	9.06	
15.0	13.7	65.1	11.46	62.3	10.88	58.6	10.09	56.6	9.70	54.7	9.31	51.0	8.55	
120%	-19.8	-20.0	29.0	7.26	28.9	7.69	28.7	8.12	28.7	8.33	28.7	8.55	28.6	8.99
	-18.8	-19.0	29.4	7.39	29.3	7.82	29.3	8.25	29.1	8.45	29.1	8.67	29.0	9.10
	-16.7	-17.0	30.6	7.69	30.4	8.10	30.2	8.50	30.3	8.71	30.3	8.92	30.1	9.32
	-13.7	-15.0	31.9	7.99	31.7	8.38	31.6	8.77	31.6	8.98	31.6	9.17	31.4	9.56
	-11.8	-13.0	33.1	8.30	33.1	8.67	33.0	9.05	33.0	9.25	32.9	9.43	32.9	9.81
	-9.8	-11.0	34.7	8.61	34.6	8.97	34.6	9.33	34.4	9.51	34.4	9.69	34.3	10.05
	-9.5	-10.0	35.6	8.77	35.4	9.12	35.3	9.46	35.3	9.65	35.3	9.82	35.1	10.17
	-8.5	-9.1	36.3	8.90	36.1	9.25	36.1	9.59	36.0	9.76	36.0	9.94	35.9	10.28
	-7.0	-7.6	37.6	9.14	37.6	9.46	37.4	9.79	37.4	9.96	37.3	10.12	37.3	10.45
	-5.0	-5.6	39.6	9.43	39.4	9.75	39.3	10.06	39.3	10.22	39.3	10.38	39.1	10.68
	-3.0	-3.7	41.4	9.71	41.4	10.01	41.3	10.31	41.3	10.45	41.1	10.61	41.1	10.90
	0.0	-0.7	44.7	10.12	44.7	10.40	44.6	10.67	44.6	10.82	44.4	10.95	44.4	11.23
	3.0	2.2	48.3	10.50	48.1	10.76	48.1	11.01	48.0	11.15	48.0	11.27	47.0	11.21
	5.0	4.1	50.7	10.73	50.6	10.98	50.6	11.22	50.4	11.34	50.4	11.46	47.0	10.53
	7.0	6.0	53.3	10.95	53.3	11.18	53.1	11.41	52.3	11.26	50.6	10.79	47.0	9.90
9.0	7.9	56.0	11.17	55.9	11.39	54.0	11.01	52.3	10.58	50.6	10.15	47.0	9.32	
11.0	9.8	58.9	11.37	57.4	11.17	54.0	10.36	52.3	9.95	50.6	9.55	47.0	8.78	
13.0	11.8	61.0	11.26	57.4	10.48	54.0	9.71	52.3	9.34	50.6	8.98	47.0	8.26	
15.0	13.7	61.0	10.60	57.4	9.87	54.0	9.16	52.3	8.81	50.6	8.47	47.0	7.80	
110%	-19.8	-20.0	28.9	7.89	28.7	8.28	28.6	8.69	28.6	8.88	28.6	9.08	28.4	9.48
	-18.8	-19.0	29.3	8.02	29.1	8.41	29.1	8.79	29.1	8.99	29.0	9.19	29.0	9.57
	-16.7	-17.0	30.4	8.28	30.3	8.66	30.7	9.04	30.1	9.22	30.1	9.42	30.0	9.78
	-13.7	-15.0	31.7	8.56	31.6	8.93	31.4	9.28	31.4	9.47	31.4	9.65	31.3	10.00
	-11.8	-13.0	33.0	8.86	33.0	9.20	32.9	9.54	32.9	9.71	32.7	9.88	32.7	10.23
	-9.8	-11.0	34.6	9.14	34.4	9.47	34.4	9.79	34.3	9.97	34.3	10.12	34.3	10.45
	-9.5	-10.0	35.4	9.28	35.3	9.60	35.1	9.93	35.1	10.09	35.1	10.25	35.0	10.56
	-8.5	-9.1	36.1	9.40	36.0	9.72	36.0	10.04	35.9	10.20	35.9	10.35	35.9	9.44
	-7.0	-7.6	37.4	9.62	37.4	9.92	37.3	10.22	37.3	10.38	37.3	10.53	37.1	10.83
	-5.0	-5.6	39.4	9.89	39.3	10.18	39.1	10.46	39.1	10.61	39.1	10.76	39.0	11.05
	-3.0	-3.7	41.3	10.15	41.3	10.42	41.1	10.70	41.1	10.83	41.0	10.96	41.0	11.24
	0.0	-0.7	44.6	10.53	44.6	10.78	44.4	11.04	44.4	11.16	44.4	11.29	43.1	11.07
	3.0	2.2	48.1	10.88	48.0	11.11	48.0	11.34	47.9	11.45	46.3	10.99	43.1	10.07
	5.0	4.1	50.6	11.09	50.6	11.32	49.6	11.21	47.9	10.76	46.3	10.33	43.1	9.48
	7.0	6.0	53.1	11.29	52.7	11.37	49.6	10.53	47.9	10.11	46.3	9.71	43.1	8.92
9.0	7.9	55.9	11.48	52.7	10.68	49.6	9.90	47.9	9.51	46.3	9.14	43.1	8.41	
11.0	9.8	55.9	10.79	52.7	10.05	49.6	9.32	47.9	8.97	46.3	8.61	43.1	7.93	
13.0	11.8	55.9	10.12	52.7	9.43	49.6	8.76	47.9	8.43	46.3	8.10	43.1	7.47	
15.0	13.7	55.9	8.99	52.7	8.89	49.6	8.27	47.9	7.96	46.3	7.66	43.1	7.07	

Abbreviations:

CR: Combination ratio

TC: Total capacity (kW)

PI: Power input (compressor + outdoor fan motor) (kW)

Notes:

1. Shaded cells indicate rating condition.

Table continued on next page ...

# VMEX 460V 60Hz

Table 2-8.12: VMEX012Q8A-D23V400 heating capacity (continued)

CR	Outdoor air temp.		Indoor air temp. °C DB											
			16.0		18.0		20.0		21.0		22.0		24.0	
	°C DB	°C WB	TC	PI	TC	PI	TC	PI	TC	PI	TC	PI	TC	PI
100%	-19.8	-20.0	28.7	8.53	28.6	8.88	28.6	9.25	28.4	9.43	28.4	9.60	28.3	9.96
	-18.8	-19.0	29.1	8.64	29.1	8.99	29.0	9.34	29.0	9.53	28.9	9.71	28.9	10.06
	-16.7	-17.0	30.3	8.88	30.1	9.22	30.1	9.56	30.0	9.73	30.0	9.90	30.0	10.24
	-13.7	-15.0	31.6	9.14	31.4	9.47	31.3	9.79	31.3	9.96	31.3	10.12	31.1	10.45
	-11.8	-13.0	32.9	9.40	32.9	9.71	32.7	10.03	32.7	10.18	32.7	10.34	32.6	10.66
	-9.8	-11.0	34.4	9.66	34.3	9.96	34.3	10.26	34.3	10.42	34.1	10.56	34.1	10.85
	-9.5	-10.0	35.3	9.79	35.1	10.09	35.1	10.38	35.0	10.53	35.0	10.67	34.9	10.96
	-8.5	-9.1	36.0	9.90	35.9	10.20	35.9	10.48	35.9	10.62	35.7	10.77	35.7	11.05
	-7.0	-7.6	37.3	10.10	37.3	10.38	37.1	10.65	37.1	10.79	37.1	10.93	37.0	11.21
	-5.0	-5.6	39.3	10.35	39.1	10.61	39.1	10.88	39.0	11.00	39.0	11.13	38.9	11.40
	-3.0	-3.7	41.1	10.59	41.1	9.61	41.0	11.09	41.0	11.21	41.0	11.33	39.3	10.85
	0.0	-0.7	44.4	10.93	44.4	11.16	44.3	11.39	43.6	11.21	42.1	10.74	39.3	9.85
	3.0	2.2	48.0	11.24	47.9	11.45	45.0	10.60	43.6	10.18	42.1	9.78	39.3	8.98
	5.0	4.1	50.4	11.45	47.9	10.76	45.0	9.96	43.6	9.59	42.1	9.21	39.3	8.47
	7.0	6.0	50.7	10.87	47.9	10.11	45.0	9.38	43.6	9.03	42.1	8.67	39.3	7.98
	9.0	7.9	50.7	10.21	47.9	9.51	45.0	8.83	43.6	8.39	42.1	8.17	39.3	7.53
11.0	9.8	50.7	9.61	47.9	8.97	45.0	8.33	43.6	8.02	42.1	7.71	39.3	7.11	
13.0	11.8	50.7	9.03	47.9	8.43	45.0	7.85	43.6	7.55	42.1	7.27	39.3	6.71	
15.0	13.7	50.7	8.52	47.9	7.96	45.0	7.41	43.6	7.14	42.1	6.87	39.3	6.36	
90%	-19.8	-20.0	28.5	9.16	28.4	9.48	28.4	9.81	28.2	9.96	28.2	10.13	28.2	10.45
	-18.8	-19.0	28.9	9.26	28.9	9.59	28.8	9.90	28.8	10.06	28.8	10.22	28.7	10.54
	-16.7	-17.0	30.1	9.49	29.9	9.79	29.9	10.10	29.9	10.26	29.8	10.40	29.8	10.71
	-13.7	-15.0	31.4	9.72	31.2	10.01	31.2	10.31	31.1	10.45	31.1	10.60	31.1	10.89
	-11.8	-13.0	32.7	9.95	32.7	10.23	32.5	10.51	32.5	10.66	32.5	10.79	32.4	11.07
	-9.8	-11.0	34.2	10.18	34.2	10.45	34.1	10.72	34.1	10.85	34.1	11.00	33.9	11.27
	-9.5	-10.0	35.1	10.31	34.9	10.57	34.9	10.83	34.8	10.96	34.8	11.10	34.8	11.35
	-8.5	-9.1	35.8	10.42	35.8	10.67	35.7	10.93	35.7	11.05	35.7	11.18	35.2	11.29
	-7.0	-7.6	37.1	10.59	37.1	10.83	36.9	11.08	36.9	11.21	36.9	11.33	35.2	10.78
	-5.0	-5.6	39.1	10.82	38.9	11.05	38.9	11.28	38.8	11.40	37.8	11.05	35.2	10.13
	-3.0	-3.7	40.9	11.02	40.9	11.24	40.5	11.29	39.1	10.84	37.8	10.40	35.2	9.55
	0.0	-0.7	44.4	11.34	43.1	11.06	40.5	10.25	39.1	9.84	37.8	9.45	35.2	8.69
	3.0	2.2	45.6	10.80	43.1	10.06	40.5	9.33	39.1	8.98	37.8	8.62	35.2	7.94
	5.0	4.1	45.6	10.16	43.1	9.46	40.5	8.80	39.1	8.45	37.8	8.14	35.2	7.49
	7.0	6.0	45.6	9.55	43.1	8.92	40.5	8.28	39.1	7.98	37.8	7.67	35.2	7.08
	9.0	7.9	45.6	9.00	43.1	8.39	40.5	7.81	39.1	7.53	37.8	7.25	35.2	6.69
11.0	9.8	45.6	8.48	43.1	7.92	40.5	7.38	39.1	7.11	37.8	6.85	35.2	6.33	
13.0	11.8	45.6	7.98	43.1	7.47	40.5	6.96	39.1	6.71	37.8	6.47	35.2	5.98	
15.0	13.7	45.6	7.54	43.1	7.05	40.5	6.59	39.1	6.36	37.8	6.13	35.2	5.68	
80%	-19.8	-20.0	28.4	9.79	28.3	10.07	28.3	10.37	28.3	10.51	28.1	10.66	28.1	10.94
	-18.8	-19.0	28.9	9.88	28.9	10.17	28.7	10.45	28.7	10.60	28.7	10.73	28.6	11.02
	-16.7	-17.0	30.0	10.09	29.9	10.35	29.9	10.63	29.9	10.77	29.9	10.90	29.7	11.17
	-13.7	-15.0	31.3	10.29	31.1	10.55	31.1	10.82	31.1	10.94	31.0	11.07	31.0	11.34
	-11.8	-13.0	32.6	10.50	32.6	10.76	32.4	11.00	32.4	11.12	32.4	11.26	31.4	10.95
	-9.8	-11.0	34.1	10.71	34.1	10.95	34.0	11.19	34.0	11.30	33.7	11.28	31.4	10.34
	-9.5	-10.0	35.0	10.82	34.9	11.05	34.9	11.28	34.9	11.40	33.7	10.95	31.4	10.04
	-8.5	-9.1	35.7	10.91	33.2	11.15	35.6	11.37	34.9	11.11	33.7	10.66	31.4	9.77
	-7.0	-7.6	37.0	11.07	37.0	11.29	36.0	11.05	34.9	10.61	33.7	10.18	31.4	9.34
	-5.0	-5.6	39.0	11.27	38.3	11.21	36.0	10.38	34.9	9.98	33.7	9.57	31.4	8.80
	-3.0	-3.7	40.6	11.33	38.3	10.55	36.0	9.77	34.9	9.40	33.7	9.03	31.4	8.31
	0.0	-0.7	40.6	10.28	38.3	9.57	36.0	8.89	34.9	8.56	33.7	8.22	31.4	7.58
	3.0	2.2	40.6	9.37	38.3	8.73	36.0	8.13	34.9	7.82	33.7	7.53	31.4	6.94
	5.0	4.1	40.6	8.82	38.3	8.23	36.0	7.66	34.9	7.38	33.7	7.11	31.4	6.57
	7.0	6.0	40.6	8.31	38.3	7.77	36.0	7.24	34.9	6.98	33.7	6.72	31.4	6.21
	9.0	7.9	40.6	7.84	38.3	7.33	36.0	6.83	34.9	6.59	33.7	6.36	31.4	5.88
11.0	9.8	40.6	7.41	38.3	6.93	36.0	6.47	34.9	6.24	33.7	6.02	31.4	5.58	
13.0	11.8	40.6	6.98	38.3	6.54	36.0	6.11	34.9	5.90	33.7	5.69	31.4	5.27	
15.0	13.7	40.6	6.60	38.3	6.20	36.0	5.80	34.9	5.59	33.7	5.40	31.4	5.02	

Abbreviations:

CR: Combination ratio

TC: Total capacity (kW)

PI: Power input (compressor + outdoor fan motor) (kW)

Notes:

1. Shaded cells indicate rating condition.

Table continued on next page ...

Table 2-8.12: VMEX012Q8A-D23V400 heating capacity (continued)

CR	Outdoor air temp.		Indoor air temp. °C DB											
			16.0		18.0		20.0		21.0		22.0		24.0	
	°C DB	°C WB	TC	PI	TC	PI	TC	PI	TC	PI	TC	PI	TC	PI
70%	-19.8	-20.0	28.2	10.43	28.1	10.67	28.1	10.93	28.1	11.05	28.1	11.18	27.4	11.06
	-18.8	-19.0	28.6	10.51	28.6	10.76	28.5	11.00	28.5	11.12	28.5	11.26	27.4	10.83
	-16.7	-17.0	29.8	10.68	29.8	10.93	29.6	11.16	29.6	11.28	29.4	10.05	27.4	10.33
	-13.7	-15.0	31.1	10.87	30.9	11.10	30.9	11.33	30.4	11.16	29.4	10.71	27.4	9.82
	-11.8	-13.0	32.4	11.05	32.4	11.27	31.5	11.00	30.4	10.57	29.4	10.15	27.4	9.31
	-9.8	-11.0	33.9	11.23	33.5	11.22	31.5	10.39	30.4	9.99	29.4	9.59	27.4	8.81
	-9.5	-10.0	34.8	11.33	33.5	10.89	31.5	10.09	30.4	9.70	29.4	9.32	27.4	8.56
	-8.5	-9.1	35.5	11.39	33.5	10.60	31.5	9.82	30.4	9.44	29.4	9.08	27.4	8.34
	-7.0	-7.6	35.5	10.88	33.5	10.12	31.5	9.39	30.4	9.04	29.4	8.69	27.4	7.99
	-5.0	-5.6	35.5	10.22	33.5	9.53	31.5	8.84	30.4	8.50	29.4	10.04	27.4	7.54
	-3.0	-3.7	35.5	9.62	33.5	8.98	31.5	8.34	30.4	8.03	29.4	7.72	27.4	7.13
	0.0	-0.7	35.5	8.76	33.5	8.19	31.5	7.61	30.4	7.33	29.4	7.07	27.4	6.53
	3.0	2.2	35.5	8.00	33.5	7.49	31.5	6.98	30.4	6.72	29.4	6.48	27.4	5.99
	5.0	4.1	35.5	7.55	33.5	7.07	31.5	6.60	30.4	6.36	29.4	6.13	27.4	5.68
	7.0	6.0	35.5	7.14	33.5	6.69	31.5	6.24	30.4	6.02	29.4	5.81	27.4	5.38
9.0	7.9	35.5	6.75	33.5	6.32	31.5	5.91	30.4	5.70	29.4	5.51	27.4	5.10	
11.0	9.8	35.5	6.38	33.5	5.98	31.5	5.60	30.4	5.41	29.4	5.23	27.4	4.85	
13.0	11.8	35.5	6.03	33.5	5.66	31.5	5.30	30.4	5.13	29.4	4.95	27.4	4.60	
15.0	13.7	35.5	5.71	33.5	5.37	31.5	5.03	30.4	4.87	29.4	4.70	27.4	4.39	
60%	-19.8	-20.0	28.1	11.06	28.0	11.27	27.0	10.84	26.1	10.41	25.3	10.00	23.6	9.17
	-18.8	-19.0	28.6	11.13	28.6	11.34	27.0	10.61	26.1	10.20	25.3	9.78	23.6	8.98
	-16.7	-17.0	29.7	11.28	28.7	10.93	27.0	10.12	26.1	9.73	25.3	9.34	23.6	8.59
	-13.7	-15.0	30.4	11.16	28.7	10.38	27.0	9.62	26.1	9.26	25.3	8.89	23.6	8.17
	-11.8	-13.0	30.4	10.56	28.7	9.83	27.0	9.12	26.1	8.78	25.3	8.44	23.6	7.81
	-9.8	-11.0	30.4	9.98	28.7	9.29	27.0	8.64	26.1	8.31	25.3	7.99	23.6	7.37
	-9.5	-10.0	30.4	9.70	28.7	9.04	27.0	8.39	26.1	8.09	25.3	7.77	23.6	7.16
	-8.5	-9.1	30.4	9.44	28.7	8.81	27.0	8.19	26.1	7.88	25.3	7.58	23.6	6.99
	-7.0	-7.6	30.4	9.03	28.7	8.43	27.0	7.83	26.1	7.55	25.3	7.26	23.6	6.71
	-5.0	-5.6	30.4	8.50	28.7	7.94	27.0	7.39	26.1	7.13	25.3	6.86	23.6	6.35
	-3.0	-3.7	30.4	8.03	28.7	7.50	27.0	6.99	26.1	6.75	25.3	6.49	23.6	6.01
	0.0	-0.7	30.4	7.33	28.7	6.87	27.0	6.41	26.1	6.19	25.3	5.96	23.6	5.52
	3.0	2.2	30.4	6.72	28.7	6.31	27.0	5.90	26.1	5.69	25.3	5.49	23.6	5.09
	5.0	4.1	30.4	6.36	28.7	5.97	27.0	5.58	26.1	5.40	25.3	5.20	23.6	4.84
	7.0	6.0	30.4	6.02	28.7	5.65	27.0	5.29	26.1	5.12	25.3	4.95	23.6	4.59
9.0	7.9	30.4	5.70	28.7	5.36	27.0	5.02	26.1	4.86	25.3	4.69	23.6	4.37	
11.0	9.8	30.4	5.41	28.7	5.09	27.0	4.77	26.1	4.62	25.3	4.46	23.6	4.17	
13.0	11.8	30.4	5.12	28.7	4.82	27.0	4.53	26.1	4.39	25.3	4.24	23.6	3.96	
15.0	13.7	30.4	4.87	28.7	4.58	27.0	4.31	26.1	4.18	25.3	4.04	23.6	3.78	
50%	-19.8	-20.0	25.3	10.06	23.9	9.37	22.5	8.70	21.6	8.38	20.9	8.05	19.5	7.42
	-18.8	-19.0	25.3	9.84	23.9	9.17	22.5	8.53	21.6	8.20	20.9	7.88	19.5	7.27
	-16.7	-17.0	25.3	9.39	23.9	8.76	22.5	8.15	21.6	7.84	20.9	7.55	19.5	6.97
	-13.7	-15.0	25.3	8.94	23.9	8.34	22.5	7.76	21.6	7.48	20.9	7.20	19.5	6.65
	-11.8	-13.0	25.3	8.49	23.9	7.93	22.5	7.38	21.6	7.11	20.9	6.85	19.5	6.33
	-9.8	-11.0	25.3	8.04	23.9	7.52	22.5	7.00	21.6	6.75	20.9	6.50	19.5	6.02
	-9.5	-10.0	25.3	7.82	23.9	7.31	22.5	6.82	21.6	6.58	20.9	6.33	19.5	5.86
	-8.5	-9.1	25.3	7.63	23.9	7.14	22.5	6.65	21.6	6.42	20.9	6.19	19.5	5.72
	-7.0	-7.6	25.3	7.31	23.9	6.85	22.5	6.38	21.6	6.16	20.9	5.94	19.5	5.51
	-5.0	-5.6	25.3	6.89	23.9	6.47	22.5	6.04	21.6	5.83	20.9	5.63	19.5	5.21
	-3.0	-3.7	25.3	6.53	23.9	6.13	22.5	5.72	21.6	5.53	20.9	5.34	19.5	4.96
	0.0	-0.7	25.3	5.99	23.9	5.63	22.5	5.27	21.6	5.09	20.9	4.92	19.5	4.58
	3.0	2.2	25.3	5.52	23.9	5.19	22.5	4.86	21.6	4.70	20.9	4.54	19.5	4.24
	5.0	4.1	25.3	5.24	23.9	4.92	22.5	4.62	21.6	4.47	20.9	4.32	19.5	4.03
	7.0	6.0	25.3	4.97	23.9	4.68	22.5	4.40	21.6	4.25	20.9	4.12	19.5	3.85
9.0	7.9	25.3	4.71	23.9	4.45	22.5	4.18	21.6	4.06	20.9	3.92	19.5	3.67	
11.0	9.8	25.3	4.48	23.9	4.23	22.5	3.98	21.6	3.86	20.9	3.74	19.5	3.50	
13.0	11.8	25.3	4.26	23.9	4.02	22.5	3.79	21.6	3.68	20.9	3.56	19.5	3.34	
15.0	13.7	25.3	4.06	23.9	3.84	22.5	3.62	21.6	3.51	20.9	3.40	19.5	3.19	

Abbreviations:

CR: Combination ratio

TC: Total capacity (kW)

PI: Power input (compressor + outdoor fan motor) (kW)

Notes:

1. Shaded cells indicate rating condition.

# VMEX 460V 60Hz

Table 2-8.13: VMEX014Q8A-D26V450 heating capacity

CR	Outdoor air temp.		Indoor air temp. °C DB											
			16.0		18.0		20.0		21.0		22.0		24.0	
	°C DB	°C WB	TC	PI	TC	PI	TC	PI	TC	PI	TC	PI	TC	PI
130%	-19.8	-20.0	32.4	7.68	32.2	8.22	32.1	8.77	32.1	9.03	31.9	9.30	31.9	9.85
	-18.8	-19.0	32.9	7.85	32.7	8.39	32.7	8.92	32.5	9.19	32.5	9.44	32.4	9.98
	-16.7	-17.0	34.1	8.22	34.0	8.72	33.8	9.25	33.8	9.50	33.8	9.75	33.7	10.26
	-13.7	-15.0	35.6	8.60	35.4	9.09	35.2	9.59	35.2	9.82	35.1	10.08	35.1	10.57
	-11.8	-13.0	37.0	8.98	37.0	9.46	36.8	9.92	36.7	10.16	36.7	10.40	36.5	10.87
	-9.8	-11.0	38.7	9.37	38.6	9.82	38.4	10.28	38.4	10.50	38.4	10.73	38.3	11.18
	-9.5	-10.0	39.7	9.57	39.5	10.01	39.4	10.45	39.4	10.67	39.2	10.88	39.2	11.32
	-8.5	-9.1	40.5	9.74	40.3	10.16	40.3	10.60	40.2	10.81	40.2	11.02	40.0	11.46
	-7.0	-7.6	41.9	10.02	41.9	10.45	41.7	10.86	41.7	11.07	41.6	11.26	41.4	11.69
	-5.0	-5.6	44.1	10.40	44.0	10.80	43.8	11.20	43.8	11.39	43.7	11.58	43.7	11.97
	-3.0	-3.7	46.2	10.74	46.0	11.12	46.0	11.49	45.9	11.69	45.9	11.87	45.7	12.24
	0.0	-0.7	49.8	11.26	49.8	11.62	49.7	11.96	49.7	12.08	49.5	12.31	49.5	12.65
	3.0	2.2	53.8	11.73	53.7	12.06	53.5	12.38	53.5	12.54	53.5	12.71	53.3	13.02
	5.0	4.1	56.5	12.03	56.3	12.34	56.3	12.63	56.2	12.79	56.2	12.95	56.0	13.24
	7.0	6.0	59.4	12.31	59.2	12.59	59.2	12.89	59.0	13.03	59.0	13.17	56.7	12.65
9.0	7.9	62.4	12.56	62.2	12.85	62.2	13.11	62.1	13.26	60.8	12.97	56.7	11.89	
11.0	9.8	65.6	12.82	65.4	13.07	65.1	13.24	62.9	12.72	60.8	12.20	56.7	11.20	
13.0	11.8	69.0	13.06	68.9	13.31	65.1	12.41	62.9	11.91	60.8	11.45	56.7	10.50	
15.0	13.7	72.4	13.28	69.2	12.61	65.1	11.69	62.9	11.24	60.8	10.79	56.7	9.91	
120%	-19.8	-20.0	32.2	8.41	32.1	8.91	31.9	9.42	31.9	9.66	31.9	9.91	31.7	10.42
	-18.8	-19.0	32.7	8.57	32.5	9.06	32.5	9.56	32.4	9.80	32.4	10.05	32.2	10.55
	-16.7	-17.0	34.0	8.91	33.8	9.39	33.6	9.85	33.7	10.09	33.7	10.33	33.5	10.80
	-13.7	-15.0	35.4	9.26	35.2	9.71	35.1	10.16	35.1	10.40	35.1	10.63	34.9	11.08
	-11.8	-13.0	36.8	9.61	36.8	10.05	36.7	10.49	36.7	10.71	36.5	10.93	36.5	11.36
	-9.8	-11.0	38.6	9.98	38.4	10.39	38.4	10.81	38.3	11.03	38.3	11.22	38.1	11.65
	-9.5	-10.0	39.5	10.16	39.4	10.57	39.2	10.97	39.2	11.18	39.2	11.38	39.0	11.79
	-8.5	-9.1	40.3	10.32	40.2	10.71	40.2	11.11	40.0	11.31	40.0	11.52	39.8	11.91
	-7.0	-7.6	41.7	10.59	41.7	10.97	41.6	11.35	41.6	11.55	41.4	11.73	41.4	12.11
	-5.0	-5.6	44.0	10.93	43.8	11.29	43.6	11.66	43.6	11.84	43.6	12.03	43.5	12.38
	-3.0	-3.7	46.0	11.25	46.0	11.60	45.9	11.94	45.9	12.11	45.7	12.30	45.7	12.64
	0.0	-0.7	49.7	11.73	49.7	12.06	49.5	12.37	49.5	12.54	49.4	12.69	49.4	13.02
	3.0	2.2	53.7	12.17	53.5	12.47	53.5	12.76	53.3	12.92	53.3	13.06	52.2	12.99
	5.0	4.1	56.4	12.44	56.2	12.72	56.2	13.00	56.0	13.14	56.0	13.28	52.2	12.20
	7.0	6.0	59.2	12.69	59.2	12.96	59.1	13.23	58.1	13.04	56.2	12.51	52.2	11.48
9.0	7.9	62.2	12.95	62.1	13.20	60.0	12.76	58.1	12.26	56.2	11.76	52.2	10.80	
11.0	9.8	65.4	13.17	63.8	12.95	60.0	12.00	58.1	11.53	56.2	11.07	52.2	10.18	
13.0	11.8	67.8	13.04	63.8	12.14	60.0	11.25	58.1	10.83	56.2	10.40	52.2	9.57	
15.0	13.7	67.8	12.28	63.8	11.44	60.0	10.62	58.1	10.21	56.2	9.81	52.2	9.03	
110%	-19.8	-20.0	32.1	9.15	31.9	9.60	31.7	10.07	31.7	10.29	31.8	10.52	31.6	10.98
	-18.8	-19.0	32.5	9.29	32.4	9.74	32.4	10.19	32.4	10.42	32.2	10.64	32.2	11.10
	-16.7	-17.0	33.8	9.60	33.7	10.04	34.1	10.47	33.5	10.69	33.5	10.91	33.3	11.34
	-13.7	-15.0	35.2	9.92	35.1	10.35	34.9	10.76	34.9	10.97	34.9	11.18	34.8	11.59
	-11.8	-13.0	36.7	10.26	36.7	10.66	36.5	11.05	36.5	11.25	36.3	11.45	36.3	11.86
	-9.8	-11.0	38.4	10.59	38.3	10.97	38.3	11.35	38.1	11.55	38.1	11.73	38.1	12.11
	-9.5	-10.0	39.4	10.76	39.2	11.12	39.0	11.51	39.0	11.69	39.0	11.87	38.9	12.24
	-8.5	-9.1	40.2	10.90	40.0	11.27	40.0	11.63	39.8	11.82	39.8	12.00	39.8	10.94
	-7.0	-7.6	41.6	11.15	41.6	11.49	41.4	11.84	41.4	12.03	41.4	12.20	41.3	12.55
	-5.0	-5.6	43.8	11.46	43.7	11.80	43.5	12.13	43.5	12.30	43.5	12.47	43.3	12.81
	-3.0	-3.7	45.9	11.76	45.9	12.07	45.7	12.39	45.7	12.55	45.6	12.71	45.6	13.03
	0.0	-0.7	49.5	12.20	49.5	12.49	49.4	12.79	49.4	12.93	49.4	13.09	47.9	12.83
	3.0	2.2	53.5	12.61	53.3	12.88	53.3	13.14	53.2	13.27	51.4	12.73	47.9	11.68
	5.0	4.1	56.2	12.85	56.2	13.11	55.1	12.99	53.2	12.47	51.4	11.97	47.9	10.98
	7.0	6.0	59.0	13.09	58.6	13.17	55.1	12.20	53.2	11.72	51.4	11.25	47.9	10.33
9.0	7.9	62.1	13.30	58.6	12.38	55.1	11.48	53.2	11.03	51.4	10.59	47.9	9.74	
11.0	9.8	62.1	12.51	58.6	11.65	55.1	10.80	53.2	10.39	51.4	9.98	47.9	9.19	
13.0	11.8	62.1	11.73	58.6	10.93	55.1	10.15	53.2	9.77	51.4	9.39	47.9	8.65	
15.0	13.7	62.1	10.42	58.6	10.31	55.1	9.59	53.2	9.22	51.4	8.88	47.9	8.19	

Abbreviations:

CR: Combination ratio

TC: Total capacity (kW)

PI: Power input (compressor + outdoor fan motor) (kW)

Notes:

1. Shaded cells indicate rating condition.

Table continued on next page ...



Table 2-8.13: VMEX014Q8A-D26V450 heating capacity (continued)

CR	Outdoor air temp.		Indoor air temp. °C DB											
			16.0		18.0		20.0		21.0		22.0		24.0	
	°C DB	°C WB	TC	PI	TC	PI	TC	PI	TC	PI	TC	PI	TC	PI
100%	-19.8	-20.0	31.9	9.88	31.7	10.29	31.7	10.71	31.6	10.93	31.6	11.12	31.4	11.55
	-18.8	-19.0	32.4	10.01	32.4	10.42	32.2	10.83	32.2	11.04	32.1	11.25	32.1	11.66
	-16.7	-17.0	33.7	10.29	33.5	10.69	33.5	11.08	33.3	11.28	33.3	11.48	33.3	11.87
	-13.7	-15.0	35.1	10.59	34.9	10.97	34.8	11.35	34.8	11.55	34.8	11.73	34.6	12.11
	-11.8	-13.0	36.5	10.90	36.5	11.25	36.4	11.62	36.4	11.80	36.4	11.99	36.2	12.35
	-9.8	-11.0	38.3	11.20	38.1	11.55	38.1	11.89	38.1	12.07	37.9	12.24	37.9	12.58
	-9.5	-10.0	39.2	11.35	39.1	11.69	39.1	12.03	38.9	12.20	38.9	12.37	38.7	12.70
	-8.5	-9.1	40.0	11.48	39.8	11.82	39.8	12.14	39.8	12.31	39.7	12.48	39.7	12.80
	-7.0	-7.6	41.4	11.70	41.4	12.03	41.3	12.34	41.3	12.51	41.3	12.66	41.1	12.99
	-5.0	-5.6	43.7	12.00	43.5	12.30	43.5	12.61	43.3	12.75	43.3	12.90	43.2	13.21
	-3.0	-3.7	45.7	12.27	45.7	11.14	45.6	12.85	45.6	12.99	45.6	13.13	43.7	12.58
	0.0	-0.7	49.4	12.66	49.4	12.93	49.2	13.20	48.4	12.99	46.8	12.45	43.7	11.42
	3.0	2.2	53.3	13.03	53.2	13.27	50.0	12.28	48.4	11.80	46.8	11.34	43.7	10.40
	5.0	4.1	56.0	13.27	53.2	12.47	50.0	11.55	48.4	11.11	46.8	10.67	43.7	9.81
	7.0	6.0	56.4	12.59	53.2	11.72	50.0	10.87	48.4	10.46	46.8	10.05	43.7	9.25
9.0	7.9	56.4	11.83	53.2	11.03	50.0	10.24	48.4	9.73	46.8	9.47	43.7	8.72	
11.0	9.8	56.4	11.14	53.2	10.39	50.0	9.66	48.4	9.29	46.8	8.94	43.7	8.24	
13.0	11.8	56.4	10.46	53.2	9.77	50.0	9.09	48.4	8.75	46.8	8.43	43.7	7.78	
15.0	13.7	56.4	9.87	53.2	9.22	50.0	8.58	48.4	8.27	46.8	7.96	43.7	7.37	
90%	-19.8	-20.0	31.7	10.62	31.5	10.98	31.5	11.36	31.4	11.55	31.4	11.74	31.4	12.11
	-18.8	-19.0	32.2	10.73	32.2	11.11	32.0	11.48	32.0	11.66	32.0	11.84	31.8	12.21
	-16.7	-17.0	33.4	11.00	33.3	11.35	33.3	11.70	33.3	11.89	33.1	12.06	33.1	12.41
	-13.7	-15.0	34.9	11.26	34.7	11.60	34.7	11.94	34.5	12.11	34.5	12.28	34.5	12.62
	-11.8	-13.0	36.3	11.53	36.3	11.86	36.1	12.18	36.1	12.35	36.1	12.51	36.0	12.83
	-9.8	-11.0	38.0	11.80	38.0	12.11	37.9	12.42	37.9	12.58	37.9	12.75	37.7	13.06
	-9.5	-10.0	39.0	11.94	38.8	12.25	38.8	12.55	38.7	12.70	38.7	12.86	38.7	13.16
	-8.5	-9.1	39.8	12.07	39.8	12.37	39.6	12.66	39.6	12.80	39.6	12.96	39.1	13.09
	-7.0	-7.6	41.2	12.27	41.2	12.55	41.0	12.85	41.0	12.99	41.0	13.13	39.1	12.49
	-5.0	-5.6	43.4	12.54	43.3	12.80	43.3	13.07	43.1	13.21	42.0	12.80	39.1	11.74
	-3.0	-3.7	45.5	12.78	45.5	13.03	45.0	13.09	43.4	12.56	42.0	12.06	39.1	11.07
	0.0	-0.7	49.3	13.14	47.9	12.82	45.0	11.87	43.4	11.41	42.0	10.95	39.1	10.06
	3.0	2.2	50.7	12.52	47.9	11.66	45.0	10.81	43.4	10.40	42.0	9.99	39.1	9.20
	5.0	4.1	50.7	11.77	47.9	10.97	45.0	10.19	43.4	9.80	42.0	9.43	39.1	8.68
	7.0	6.0	50.7	11.07	47.9	10.33	45.0	9.60	43.4	9.25	42.0	8.89	39.1	8.20
9.0	7.9	50.7	10.43	47.9	9.73	45.0	9.05	43.4	8.72	42.0	8.40	39.1	7.75	
11.0	9.8	50.7	9.82	47.9	9.18	45.0	8.55	43.4	8.24	42.0	7.93	39.1	7.34	
13.0	11.8	50.7	9.25	47.9	8.65	45.0	8.06	43.4	7.78	42.0	7.50	39.1	6.93	
15.0	13.7	50.7	8.74	47.9	8.17	45.0	7.64	43.4	7.37	42.0	7.10	39.1	6.58	
80%	-19.8	-20.0	31.6	11.35	31.4	11.67	31.4	12.01	31.4	12.18	31.3	12.35	31.3	12.68
	-18.8	-19.0	32.1	11.45	32.1	11.79	31.9	12.11	31.9	12.28	31.9	12.44	31.7	12.78
	-16.7	-17.0	33.3	11.69	33.2	12.00	33.2	12.32	33.2	12.48	33.2	12.63	33.0	12.94
	-13.7	-15.0	34.8	11.93	34.6	12.22	34.6	12.53	34.6	12.68	34.4	12.83	34.4	13.14
	-11.8	-13.0	36.2	12.17	36.2	12.46	36.0	12.75	36.0	12.89	36.0	13.04	34.9	12.69
	-9.8	-11.0	37.9	12.41	37.9	12.69	37.8	12.97	37.8	13.10	37.5	13.07	34.9	11.98
	-9.5	-10.0	38.9	12.53	38.7	12.80	38.7	13.07	38.7	13.21	37.5	12.69	34.9	11.63
	-8.5	-9.1	39.7	12.65	36.9	12.92	39.5	13.17	38.7	12.87	37.5	12.35	34.9	11.32
	-7.0	-7.6	41.1	12.83	41.1	13.09	40.0	12.80	38.7	12.30	37.5	11.80	34.9	10.83
	-5.0	-5.6	43.3	13.06	42.5	12.99	40.0	12.03	38.7	11.56	37.5	11.10	34.9	10.19
	-3.0	-3.7	45.1	13.13	42.5	12.22	40.0	11.32	38.7	10.90	37.5	10.46	34.9	9.63
	0.0	-0.7	45.1	11.91	42.5	11.10	40.0	10.31	38.7	9.92	37.5	9.53	34.9	8.78
	3.0	2.2	45.1	10.86	42.5	10.12	40.0	9.42	38.7	9.06	37.5	8.72	34.9	8.05
	5.0	4.1	45.1	10.22	42.5	9.54	40.0	8.88	38.7	8.55	37.5	8.24	34.9	7.61
	7.0	6.0	45.1	9.63	42.5	9.01	40.0	8.39	38.7	8.09	37.5	7.79	34.9	7.20
9.0	7.9	45.1	9.09	42.5	8.50	40.0	7.92	38.7	7.64	37.5	7.37	34.9	6.82	
11.0	9.8	45.1	8.58	42.5	8.03	40.0	7.50	38.7	7.23	37.5	6.97	34.9	6.46	
13.0	11.8	45.1	8.09	42.5	7.58	40.0	7.09	38.7	6.83	37.5	6.59	34.9	6.11	
15.0	13.7	45.1	7.65	42.5	7.19	40.0	6.72	38.7	6.48	37.5	6.25	34.9	5.82	

Abbreviations:

CR: Combination ratio

TC: Total capacity (kW)

PI: Power input (compressor + outdoor fan motor) (kW)

Notes:

1. Shaded cells indicate rating condition.

Table continued on next page ...

# VMEX 460V 60Hz

Table 2-8.13: VMEX014Q8A-D26V450 heating capacity (continued)

CR	Outdoor air temp.		Indoor air temp. °C DB											
			16.0		18.0		20.0		21.0		22.0		24.0	
	°C DB	°C WB	TC	PI	TC	PI	TC	PI	TC	PI	TC	PI	TC	PI
70%	-19.8	-20.0	31.4	12.08	31.2	12.37	31.2	12.66	31.2	12.80	31.2	12.96	30.4	12.82
	-18.8	-19.0	31.8	12.18	31.8	12.46	31.7	12.75	31.7	12.89	31.7	13.04	30.4	12.55
	-16.7	-17.0	33.1	12.38	33.1	12.66	32.9	12.93	32.9	13.07	32.6	11.65	30.4	11.97
	-13.7	-15.0	34.5	12.59	34.4	12.86	34.4	13.13	33.7	12.93	32.6	12.41	30.4	11.38
	-11.8	-13.0	35.9	12.80	35.9	13.06	35.0	12.75	33.7	12.25	32.6	11.76	30.4	10.78
	-9.8	-11.0	37.7	13.02	37.2	13.00	35.0	12.04	33.7	11.58	32.6	11.11	30.4	10.21
	-9.5	-10.0	38.6	13.13	37.2	12.62	35.0	11.69	33.7	11.24	32.6	10.80	30.4	9.92
	-8.5	-9.1	39.4	13.20	37.2	12.28	35.0	11.38	33.7	10.94	32.6	10.52	30.4	9.67
	-7.0	-7.6	39.4	12.61	37.2	11.73	35.0	10.88	33.7	10.47	32.6	10.06	30.4	9.26
	-5.0	-5.6	39.4	11.84	37.2	11.04	35.0	10.25	33.7	9.85	32.6	11.64	30.4	8.74
	-3.0	-3.7	39.4	11.15	37.2	10.40	35.0	9.67	33.7	9.30	32.6	8.95	30.4	8.26
	0.0	-0.7	39.4	10.15	37.2	9.49	35.0	8.82	33.7	8.50	32.6	8.19	30.4	7.57
	3.0	2.2	39.4	9.27	37.2	8.68	35.0	8.09	33.7	7.79	32.6	7.51	30.4	6.94
	5.0	4.1	39.4	8.75	37.2	8.19	35.0	7.65	33.7	7.37	32.6	7.10	30.4	6.58
	7.0	6.0	39.4	8.27	37.2	7.75	35.0	7.23	33.7	6.97	32.6	6.73	30.4	6.24
9.0	7.9	39.4	7.82	37.2	7.33	35.0	6.85	33.7	6.61	32.6	6.38	30.4	5.91	
11.0	9.8	39.4	7.40	37.2	6.93	35.0	6.49	33.7	6.27	32.6	6.06	30.4	5.62	
13.0	11.8	39.4	6.99	37.2	6.56	35.0	6.14	33.7	5.94	32.6	5.73	30.4	5.34	
15.0	13.7	39.4	6.62	37.2	6.23	35.0	5.83	33.7	5.65	32.6	5.45	30.4	5.08	
60%	-19.8	-20.0	31.3	12.82	31.1	13.06	30.0	12.56	29.0	12.07	28.1	11.59	26.2	10.63
	-18.8	-19.0	31.7	12.90	31.7	13.14	30.0	12.29	29.0	11.82	28.1	11.33	26.2	10.40
	-16.7	-17.0	33.0	13.07	31.9	12.66	30.0	11.73	29.0	11.28	28.1	10.83	26.2	9.95
	-13.7	-15.0	33.8	12.93	31.9	12.03	30.0	11.15	29.0	10.73	28.1	10.30	26.2	9.47
	-11.8	-13.0	33.8	12.24	31.9	11.39	30.0	10.57	29.0	10.18	28.1	9.78	26.2	9.05
	-9.8	-11.0	33.8	11.56	31.9	10.77	30.0	10.01	29.0	9.63	28.1	9.26	26.2	8.54
	-9.5	-10.0	33.8	11.24	31.9	10.47	30.0	9.73	29.0	9.37	28.1	9.01	26.2	8.30
	-8.5	-9.1	33.8	10.94	31.9	10.21	30.0	9.49	29.0	9.13	28.1	8.78	26.2	8.10
	-7.0	-7.6	33.8	10.46	31.9	9.77	30.0	9.08	29.0	8.75	28.1	8.41	26.2	7.78
	-5.0	-5.6	33.8	9.85	31.9	9.20	30.0	8.57	29.0	8.26	28.1	7.95	26.2	7.35
	-3.0	-3.7	33.8	9.30	31.9	8.70	30.0	8.10	29.0	7.82	28.1	7.52	26.2	6.96
	0.0	-0.7	33.8	8.50	31.9	7.96	30.0	7.43	29.0	7.17	28.1	6.90	26.2	6.39
	3.0	2.2	33.8	7.79	31.9	7.31	30.0	6.83	29.0	6.59	28.1	6.37	26.2	5.90
	5.0	4.1	33.8	7.37	31.9	6.92	30.0	6.47	29.0	6.25	28.1	6.03	26.2	5.60
	7.0	6.0	33.8	6.97	31.9	6.55	30.0	6.13	29.0	5.93	28.1	5.73	26.2	5.32
9.0	7.9	33.8	6.61	31.9	6.21	30.0	5.82	29.0	5.63	28.1	5.43	26.2	5.07	
11.0	9.8	33.8	6.27	31.9	5.90	30.0	5.53	29.0	5.35	28.1	5.17	26.2	4.83	
13.0	11.8	33.8	5.93	31.9	5.59	30.0	5.25	29.0	5.08	28.1	4.91	26.2	4.59	
15.0	13.7	33.8	5.65	31.9	5.31	30.0	5.00	29.0	4.84	28.1	4.69	26.2	4.38	
50%	-19.8	-20.0	28.2	11.66	26.6	10.86	25.0	10.08	24.1	9.71	23.3	9.33	21.7	8.60
	-18.8	-19.0	28.2	11.41	26.6	10.63	25.0	9.88	24.1	9.50	23.3	9.13	21.7	8.43
	-16.7	-17.0	28.2	10.88	26.6	10.15	25.0	9.44	24.1	9.09	23.3	8.75	21.7	8.07
	-13.7	-15.0	28.2	10.36	26.6	9.67	25.0	8.99	24.1	8.67	23.3	8.34	21.7	7.71
	-11.8	-13.0	28.2	9.84	26.6	9.19	25.0	8.55	24.1	8.24	23.3	7.93	21.7	7.34
	-9.8	-11.0	28.2	9.32	26.6	8.71	25.0	8.12	24.1	7.82	23.3	7.54	21.7	6.97
	-9.5	-10.0	28.2	9.06	26.6	8.47	25.0	7.90	24.1	7.62	23.3	7.34	21.7	6.79
	-8.5	-9.1	28.2	8.84	26.6	8.27	25.0	7.71	24.1	7.44	23.3	7.17	21.7	6.63
	-7.0	-7.6	28.2	8.47	26.6	7.93	25.0	7.40	24.1	7.14	23.3	6.89	21.7	6.38
	-5.0	-5.6	28.2	7.99	26.6	7.50	25.0	7.00	24.1	6.76	23.3	6.52	21.7	6.04
	-3.0	-3.7	28.2	7.57	26.6	7.10	25.0	6.63	24.1	6.41	23.3	6.18	21.7	5.75
	0.0	-0.7	28.2	6.95	26.6	6.52	25.0	6.11	24.1	5.90	23.3	5.70	21.7	5.31
	3.0	2.2	28.2	6.39	26.6	6.01	25.0	5.63	24.1	5.45	23.3	5.27	21.7	4.91
	5.0	4.1	28.2	6.07	26.6	5.70	25.0	5.35	24.1	5.18	23.3	5.01	21.7	4.67
	7.0	6.0	28.2	5.76	26.6	5.42	25.0	5.10	24.1	4.93	23.3	4.77	21.7	4.46
9.0	7.9	28.2	5.46	26.6	5.15	25.0	4.84	24.1	4.70	23.3	4.55	21.7	4.25	
11.0	9.8	28.2	5.19	26.6	4.90	25.0	4.62	24.1	4.47	23.3	4.33	21.7	4.05	
13.0	11.8	28.2	4.94	26.6	4.66	25.0	4.39	24.1	4.26	23.3	4.12	21.7	3.87	
15.0	13.7	28.2	4.70	26.6	4.45	25.0	4.19	24.1	4.07	23.3	3.94	21.7	3.70	

**Abbreviations:**

CR: Combination ratio

TC: Total capacity (kW)

PI: Power input (compressor + outdoor fan motor) (kW)

**Notes:**

1. Shaded cells indicate rating condition.

Table 2-8.14: VMEX016Q8A-D29V500 heating capacity

CR	Outdoor air temp.		Indoor air temp. °C DB											
			16.0		18.0		20.0		21.0		22.0		24.0	
	°C DB	°C WB	TC	PI	TC	PI	TC	PI	TC	PI	TC	PI	TC	PI
130%	-19.8	-20.0	36.3	9.31	36.1	9.96	35.9	10.63	35.9	10.95	35.7	11.28	35.7	11.95
	-18.8	-19.0	36.8	9.52	36.6	10.17	36.6	10.82	36.4	11.14	36.4	11.45	36.3	12.10
	-16.7	-17.0	38.2	9.96	38.0	10.58	37.9	11.21	37.9	11.52	37.9	11.83	37.7	12.44
	-13.7	-15.0	39.8	10.42	39.6	11.02	39.5	11.62	39.5	11.91	39.3	12.22	39.3	12.82
	-11.8	-13.0	41.4	10.89	41.4	11.47	41.2	12.03	41.1	12.32	41.1	12.61	40.9	13.18
	-9.8	-11.0	43.4	11.37	43.2	11.91	43.0	12.46	43.0	12.73	43.0	13.01	42.8	13.56
	-9.5	-10.0	44.4	11.61	44.3	12.14	44.1	12.67	44.1	12.94	43.9	13.20	43.9	13.73
	-8.5	-9.1	45.3	11.81	45.2	12.32	45.2	12.86	45.0	13.11	45.0	13.37	44.8	13.90
	-7.0	-7.6	46.9	12.15	46.9	12.67	46.8	13.16	46.8	13.42	46.6	13.66	46.4	14.17
	-5.0	-5.6	49.4	12.61	49.2	13.09	49.1	13.57	49.1	13.81	48.9	14.04	48.9	14.51
	-3.0	-3.7	51.7	13.03	51.6	13.49	51.6	13.93	51.4	14.17	51.4	14.39	51.2	14.84
	0.0	-0.7	55.8	13.66	55.8	14.09	55.6	14.50	55.6	14.65	55.5	14.93	55.5	15.34
	3.0	2.2	60.3	14.22	60.1	14.62	59.9	15.01	59.9	15.20	59.9	15.41	59.7	15.78
	5.0	4.1	63.3	14.58	63.1	14.96	63.1	15.32	62.9	15.51	62.9	15.70	62.8	16.06
	7.0	6.0	66.5	14.93	66.3	15.27	66.3	15.63	66.1	15.80	66.1	15.97	63.5	15.34
9.0	7.9	69.9	15.23	69.7	15.58	69.7	15.90	69.5	16.07	68.1	15.73	63.5	14.41	
11.0	9.8	73.4	15.54	73.2	15.85	72.9	16.06	70.4	15.42	68.1	14.79	63.5	13.57	
13.0	11.8	77.3	15.83	77.2	16.14	72.9	15.05	70.4	14.45	68.1	13.88	63.5	12.73	
15.0	13.7	81.1	16.11	77.5	15.29	72.9	14.17	70.4	13.63	68.1	13.08	63.5	12.02	
120%	-19.8	-20.0	36.1	10.20	35.9	10.80	35.7	11.42	35.7	11.71	35.7	12.02	35.6	12.63
	-18.8	-19.0	36.6	10.39	36.4	10.99	36.4	11.59	36.3	11.88	36.3	12.19	36.1	12.79
	-16.7	-17.0	38.0	10.80	37.9	11.38	37.6	11.95	37.7	12.24	37.7	12.53	37.5	13.09
	-13.7	-15.0	39.6	11.23	39.5	11.78	39.3	12.32	39.3	12.62	39.3	12.89	39.1	13.44
	-11.8	-13.0	41.2	11.66	41.2	12.19	41.1	12.72	41.1	12.99	40.9	13.25	40.9	13.78
	-9.8	-11.0	43.2	12.10	43.0	12.60	43.0	13.11	42.8	13.37	42.8	13.61	42.7	14.12
	-9.5	-10.0	44.3	12.32	44.1	12.82	43.9	13.30	43.9	13.56	43.9	13.80	43.7	14.29
	-8.5	-9.1	45.2	12.51	45.0	12.99	45.0	13.47	44.8	13.71	44.8	13.97	44.6	14.45
	-7.0	-7.6	46.8	12.84	46.8	13.30	46.6	13.76	46.6	14.00	46.4	14.22	46.4	14.69
	-5.0	-5.6	49.2	13.25	49.1	13.69	48.9	14.14	48.9	14.36	48.9	14.58	48.7	15.01
	-3.0	-3.7	51.6	13.64	51.6	14.07	51.4	14.48	51.4	14.69	51.2	14.91	51.2	15.32
	0.0	-0.7	55.6	14.22	55.6	14.62	55.5	14.99	55.5	15.20	55.3	15.39	55.3	15.78
	3.0	2.2	60.1	14.76	59.9	15.11	59.9	15.47	59.7	15.66	59.7	15.83	58.5	15.75
	5.0	4.1	63.1	15.08	62.9	15.42	62.9	15.76	62.8	15.94	62.8	16.11	58.5	14.79
	7.0	6.0	66.3	15.39	66.3	15.71	66.1	16.04	65.1	15.82	62.9	15.17	58.5	13.92
9.0	7.9	69.7	15.70	69.5	16.01	67.2	15.47	65.1	14.86	62.9	14.26	58.5	13.09	
11.0	9.8	73.2	15.97	71.5	15.70	67.2	14.55	65.1	13.98	62.9	13.42	58.5	12.34	
13.0	11.8	75.9	15.82	71.5	14.72	67.2	13.64	65.1	13.13	62.9	12.62	58.5	11.61	
15.0	13.7	75.9	14.89	71.5	13.87	67.2	12.87	65.1	12.38	62.9	11.90	58.5	10.95	
110%	-19.8	-20.0	35.9	11.09	35.7	11.64	35.6	12.20	35.6	12.48	35.6	12.75	35.4	13.32
	-18.8	-19.0	36.4	11.26	36.3	11.81	36.3	12.36	36.3	12.63	36.1	12.91	36.1	13.45
	-16.7	-17.0	37.9	11.64	37.7	12.17	38.2	12.70	37.5	12.96	37.5	13.23	37.3	13.75
	-13.7	-15.0	39.5	12.03	39.3	12.55	39.1	13.04	39.1	13.30	39.1	13.56	38.9	14.05
	-11.8	-13.0	41.1	12.44	41.1	12.92	40.9	13.40	40.9	13.64	40.7	13.88	40.7	14.38
	-9.8	-11.0	43.0	12.84	42.8	13.30	42.8	13.76	42.7	14.00	42.7	14.22	42.7	14.69
	-9.5	-10.0	44.1	13.04	43.9	13.49	43.7	13.95	43.7	14.17	43.7	14.40	43.6	14.84
	-8.5	-9.1	45.0	13.21	44.8	13.66	44.8	14.10	44.6	14.33	44.6	14.55	44.6	13.27
	-7.0	-7.6	46.6	13.52	46.6	13.93	46.4	14.36	46.4	14.58	46.4	14.79	46.2	15.22
	-5.0	-5.6	49.1	13.90	48.9	14.31	48.7	14.70	48.7	14.91	48.7	15.11	48.5	15.53
	-3.0	-3.7	51.4	14.26	51.4	14.64	51.2	15.03	51.2	15.22	51.0	15.41	51.0	15.80
	0.0	-0.7	55.5	14.79	55.5	15.15	55.3	15.51	55.3	15.68	55.3	15.87	53.7	15.56
	3.0	2.2	59.9	15.29	59.7	15.61	59.7	15.94	59.6	16.09	57.6	15.44	53.7	14.16
	5.0	4.1	62.9	15.58	62.9	15.90	61.7	15.75	59.6	15.11	57.6	14.52	53.7	13.32
	7.0	6.0	66.1	15.87	65.6	15.97	61.7	14.79	59.6	14.21	57.6	13.64	53.7	12.53
9.0	7.9	69.5	16.12	65.6	15.01	61.7	13.92	59.6	13.37	57.6	12.84	53.7	11.81	
11.0	9.8	69.5	15.17	65.6	14.12	61.7	13.09	59.6	12.60	57.6	12.10	53.7	11.14	
13.0	11.8	69.5	14.22	65.6	13.25	61.7	12.31	59.6	11.84	57.6	11.38	53.7	10.49	
15.0	13.7	69.5	12.63	65.6	12.50	61.7	11.62	59.6	11.18	57.6	10.77	53.7	9.93	

Abbreviations:

CR: Combination ratio

TC: Total capacity (kW)

PI: Power input (compressor + outdoor fan motor) (kW)

Notes:

1. Shaded cells indicate rating condition.

Table continued on next page ...

# VMEX 460V 60Hz

Table 2-8.14: VMEX016Q8A-D29V500 heating capacity (continued)

CR	Outdoor air temp.		Indoor air temp. °C DB											
			16.0		18.0		20.0		21.0		22.0		24.0	
	°C DB	°C WB	TC	PI	TC	PI	TC	PI	TC	PI	TC	PI	TC	PI
100%	-19.8	-20.0	35.7	11.98	35.6	12.48	35.6	12.99	35.4	13.25	35.4	13.49	35.2	14.00
	-18.8	-19.0	36.3	12.14	36.3	12.63	36.1	13.13	36.1	13.39	35.9	13.64	35.9	14.14
	-16.7	-17.0	37.7	12.48	37.5	12.96	37.5	13.44	37.3	13.68	37.3	13.92	37.3	14.40
	-13.7	-15.0	39.3	12.84	39.1	13.30	38.9	13.76	38.9	14.00	38.9	14.22	38.8	14.69
	-11.8	-13.0	40.9	13.21	40.9	13.64	40.7	14.09	40.7	14.31	40.7	14.53	40.5	14.98
	-9.8	-11.0	42.8	13.57	42.7	14.00	42.7	14.41	42.7	14.64	42.5	14.84	42.5	15.25
	-9.5	-10.0	43.9	13.76	43.7	14.17	43.7	14.58	43.6	14.79	43.6	14.99	43.4	15.40
	-8.5	-9.1	44.8	13.92	44.6	14.33	44.6	14.72	44.6	14.93	44.4	15.13	44.4	15.52
	-7.0	-7.6	46.4	14.19	46.4	14.58	46.2	14.96	46.2	15.16	46.2	15.35	46.0	15.75
	-5.0	-5.6	48.9	14.55	48.7	14.91	48.7	15.28	48.5	15.46	48.5	15.64	48.4	16.02
	-3.0	-3.7	51.2	14.87	51.2	15.51	51.0	15.58	51.0	15.75	51.0	15.92	48.9	15.25
	0.0	-0.7	55.3	15.35	55.3	15.68	55.1	16.00	54.2	15.75	52.4	15.10	48.9	13.85
	3.0	2.2	59.7	15.80	59.6	16.09	56.0	14.89	54.2	14.31	52.4	13.75	48.9	12.61
	5.0	4.1	62.8	16.09	59.6	15.11	56.0	14.00	54.2	13.47	52.4	12.94	48.9	11.90
	7.0	6.0	63.1	15.27	59.6	14.21	56.0	13.18	54.2	12.68	52.4	12.19	48.9	11.21
	9.0	7.9	63.1	14.34	59.6	13.37	56.0	12.41	54.2	11.79	52.4	11.49	48.9	10.58
11.0	9.8	63.1	13.51	59.6	12.60	56.0	11.71	54.2	11.26	52.4	10.84	48.9	10.00	
13.0	11.8	63.1	12.68	59.6	11.84	56.0	11.02	54.2	10.61	52.4	10.22	48.9	9.43	
15.0	13.7	63.1	11.96	59.6	11.18	56.0	10.41	54.2	10.03	52.4	9.65	48.9	8.93	
90%	-19.8	-20.0	35.5	12.87	35.3	13.32	35.3	13.78	35.1	14.00	35.1	14.24	35.1	14.69
	-18.8	-19.0	36.0	13.01	36.0	13.47	35.8	13.92	35.8	14.14	35.8	14.36	35.7	14.81
	-16.7	-17.0	37.4	13.33	37.3	13.76	37.3	14.19	37.3	14.41	37.1	14.62	37.1	15.04
	-13.7	-15.0	39.0	13.66	38.9	14.07	38.9	14.48	38.7	14.69	38.7	14.89	38.7	15.30
	-11.8	-13.0	40.6	13.98	40.6	14.38	40.5	14.77	40.5	14.98	40.5	15.16	40.3	15.56
	-9.8	-11.0	42.6	14.31	42.6	14.69	42.4	15.06	42.4	15.25	42.4	15.46	42.2	15.83
	-9.5	-10.0	43.7	14.48	43.5	14.86	43.5	15.22	43.3	15.40	43.3	15.59	43.3	15.95
	-8.5	-9.1	44.5	14.64	44.5	14.99	44.4	15.35	44.4	15.52	44.4	15.71	43.8	15.87
	-7.0	-7.6	46.1	14.87	46.1	15.22	46.0	15.58	46.0	15.75	46.0	15.92	43.8	15.15
	-5.0	-5.6	48.6	15.20	48.4	15.52	48.4	15.85	48.3	16.02	47.0	15.52	43.8	14.24
	-3.0	-3.7	50.9	15.49	50.9	15.80	50.4	15.87	48.6	15.23	47.0	14.62	43.8	13.42
	0.0	-0.7	55.2	15.94	53.6	15.54	50.4	14.40	48.6	13.83	47.0	13.28	43.8	12.20
	3.0	2.2	56.8	15.18	53.6	14.14	50.4	13.11	48.6	12.61	47.0	12.12	43.8	11.16
	5.0	4.1	56.8	14.28	53.6	13.30	50.4	12.36	48.6	11.88	47.0	11.43	43.8	10.53
	7.0	6.0	56.8	13.42	53.6	12.53	50.4	11.64	48.6	11.21	47.0	10.78	43.8	9.94
	9.0	7.9	56.8	12.65	53.6	11.79	50.4	10.97	48.6	10.58	47.0	10.18	43.8	9.40
11.0	9.8	56.8	11.91	53.6	11.13	50.4	10.37	48.6	10.00	47.0	9.62	43.8	8.90	
13.0	11.8	56.8	11.21	53.6	10.49	50.4	9.77	48.6	9.43	47.0	9.09	43.8	8.40	
15.0	13.7	56.8	10.60	53.6	9.91	50.4	9.26	48.6	8.93	47.0	8.61	43.8	7.98	
80%	-19.8	-20.0	35.4	13.76	35.2	14.16	35.2	14.57	35.2	14.77	35.0	14.98	35.0	15.37
	-18.8	-19.0	35.9	13.88	35.9	14.29	35.7	14.69	35.7	14.89	35.7	15.08	35.6	15.49
	-16.7	-17.0	37.3	14.17	37.2	14.55	37.2	14.94	37.2	15.13	37.2	15.32	37.0	15.70
	-13.7	-15.0	38.9	14.46	38.8	14.82	38.8	15.20	38.8	15.37	38.6	15.56	38.6	15.93
	-11.8	-13.0	40.5	14.75	40.5	15.11	40.4	15.46	40.4	15.63	40.4	15.82	39.1	15.39
	-9.8	-11.0	42.5	15.05	42.5	15.39	42.3	15.73	42.3	15.88	42.0	15.85	39.1	14.53
	-9.5	-10.0	43.6	15.20	43.4	15.52	43.4	15.85	43.4	16.02	42.0	15.39	39.1	14.10
	-8.5	-9.1	44.4	15.34	41.3	15.66	44.3	15.97	43.4	15.61	42.0	14.98	39.1	13.73
	-7.0	-7.6	46.0	15.56	46.0	15.87	44.8	15.52	43.4	14.91	42.0	14.31	39.1	13.13
	-5.0	-5.6	48.5	15.83	47.6	15.75	44.8	14.58	43.4	14.02	42.0	13.45	39.1	12.36
	-3.0	-3.7	50.5	15.92	47.6	14.82	44.8	13.73	43.4	13.21	42.0	12.68	39.1	11.67
	0.0	-0.7	50.5	14.45	47.6	13.45	44.8	12.50	43.4	12.03	42.0	11.55	39.1	10.65
	3.0	2.2	50.5	13.16	47.6	12.27	44.8	11.42	43.4	10.99	42.0	10.58	39.1	9.76
	5.0	4.1	50.5	12.39	47.6	11.57	44.8	10.77	43.4	10.37	42.0	10.00	39.1	9.23
	7.0	6.0	50.5	11.67	47.6	10.92	44.8	10.17	43.4	9.81	42.0	9.45	39.1	8.73
	9.0	7.9	50.5	11.02	47.6	10.30	44.8	9.60	43.4	9.26	42.0	8.93	39.1	8.27
11.0	9.8	50.5	10.41	47.6	9.74	44.8	9.09	43.4	8.76	42.0	8.45	39.1	7.84	
13.0	11.8	50.5	9.81	47.6	9.19	44.8	8.59	43.4	8.28	42.0	7.99	39.1	7.41	
15.0	13.7	50.5	9.28	47.6	8.71	44.8	8.15	43.4	7.86	42.0	7.58	39.1	7.05	

Abbreviations:

CR: Combination ratio

TC: Total capacity (kW)

PI: Power input (compressor + outdoor fan motor) (kW)

Notes:

1. Shaded cells indicate rating condition.

Table continued on next page ...

Table 2-8.14: VMEX016Q8A-D29V500 heating capacity (continued)

CR	Outdoor air temp.		Indoor air temp. °C DB											
			16.0		18.0		20.0		21.0		22.0		24.0	
	°C DB	°C WB	TC	PI	TC	PI	TC	PI	TC	PI	TC	PI	TC	PI
70%	-19.8	-20.0	35.1	14.65	34.9	14.99	34.9	15.35	34.9	15.52	34.9	15.71	34.1	15.54
	-18.8	-19.0	35.7	14.77	35.7	15.11	35.5	15.46	35.5	15.63	35.5	15.82	34.1	15.22
	-16.7	-17.0	37.1	15.01	37.1	15.35	36.9	15.68	36.9	15.85	36.5	14.12	34.1	14.51
	-13.7	-15.0	38.7	15.27	38.5	15.59	38.5	15.92	37.8	15.68	36.5	15.04	34.1	13.80
	-11.8	-13.0	40.3	15.52	40.3	15.83	39.2	15.46	37.8	14.86	36.5	14.26	34.1	13.08
	-9.8	-11.0	42.2	15.78	41.7	15.76	39.2	14.60	37.8	14.04	36.5	13.47	34.1	12.37
	-9.5	-10.0	43.3	15.92	41.7	15.30	39.2	14.17	37.8	13.62	36.5	13.09	34.1	12.03
	-8.5	-9.1	44.2	16.00	41.7	14.89	39.2	13.80	37.8	13.27	36.5	12.75	34.1	11.72
	-7.0	-7.6	44.2	15.28	41.7	14.22	39.2	13.20	37.8	12.70	36.5	12.20	34.1	11.23
	-5.0	-5.6	44.2	14.36	41.7	13.38	39.2	12.43	37.8	11.95	36.5	14.11	34.1	10.59
	-3.0	-3.7	44.2	13.52	41.7	12.61	39.2	11.72	37.8	11.28	36.5	10.85	34.1	10.01
	0.0	-0.7	44.2	12.31	41.7	11.50	39.2	10.70	37.8	10.30	36.5	9.93	34.1	9.17
	3.0	2.2	44.2	11.25	41.7	10.53	39.2	9.81	37.8	9.45	36.5	9.11	34.1	8.42
	5.0	4.1	44.2	10.61	41.7	9.93	39.2	9.28	37.8	8.93	36.5	8.61	34.1	7.98
	7.0	6.0	44.2	10.03	41.7	9.40	39.2	8.76	37.8	8.45	36.5	8.16	34.1	7.57
9.0	7.9	44.2	9.48	41.7	8.88	39.2	8.30	37.8	8.01	36.5	7.74	34.1	7.17	
11.0	9.8	44.2	8.97	41.7	8.40	39.2	7.87	37.8	7.60	36.5	7.34	34.1	6.81	
13.0	11.8	44.2	8.47	41.7	7.96	39.2	7.45	37.8	7.21	36.5	6.95	34.1	6.47	
15.0	13.7	44.2	8.03	41.7	7.55	39.2	7.07	37.8	6.85	36.5	6.61	34.1	6.16	
60%	-19.8	-20.0	35.0	15.54	34.8	15.83	33.6	15.23	32.5	14.63	31.5	14.05	29.3	12.89
	-18.8	-19.0	35.6	15.64	35.6	15.94	33.6	14.91	32.5	14.33	31.5	13.74	29.3	12.61
	-16.7	-17.0	37.0	15.85	35.7	15.35	33.6	14.22	32.5	13.68	31.5	13.13	29.3	12.07
	-13.7	-15.0	37.9	15.68	35.7	14.58	33.6	13.52	32.5	13.01	31.5	12.49	29.3	11.48
	-11.8	-13.0	37.9	14.84	35.7	13.81	33.6	12.82	32.5	12.34	31.5	11.86	29.3	10.97
	-9.8	-11.0	37.9	14.02	35.7	13.06	33.6	12.13	32.5	11.67	31.5	11.23	29.3	10.35
	-9.5	-10.0	37.9	13.62	35.7	12.70	33.6	11.79	32.5	11.37	31.5	10.92	29.3	10.06
	-8.5	-9.1	37.9	13.26	35.7	12.37	33.6	11.50	32.5	11.07	31.5	10.65	29.3	9.82
	-7.0	-7.6	37.9	12.68	35.7	11.84	33.6	11.01	32.5	10.61	31.5	10.20	29.3	9.43
	-5.0	-5.6	37.9	11.95	35.7	11.16	33.6	10.39	32.5	10.01	31.5	9.64	29.3	8.92
	-3.0	-3.7	37.9	11.28	35.7	10.54	33.6	9.82	32.5	9.48	31.5	9.12	29.3	8.44
	0.0	-0.7	37.9	10.30	35.7	9.65	33.6	9.00	32.5	8.69	31.5	8.37	29.3	7.75
	3.0	2.2	37.9	9.45	35.7	8.87	33.6	8.28	32.5	7.99	31.5	7.72	29.3	7.15
	5.0	4.1	37.9	8.93	35.7	8.39	33.6	7.84	32.5	7.58	31.5	7.31	29.3	6.79
	7.0	6.0	37.9	8.45	35.7	7.94	33.6	7.43	32.5	7.19	31.5	6.95	29.3	6.45
9.0	7.9	37.9	8.01	35.7	7.53	33.6	7.05	32.5	6.83	31.5	6.59	29.3	6.14	
11.0	9.8	37.9	7.60	35.7	7.15	33.6	6.71	32.5	6.49	31.5	6.26	29.3	5.85	
13.0	11.8	37.9	7.19	35.7	6.78	33.6	6.37	32.5	6.16	31.5	5.96	29.3	5.56	
15.0	13.7	37.9	6.85	35.7	6.44	33.6	6.06	32.5	5.87	31.5	5.68	29.3	5.31	
50%	-19.8	-20.0	31.5	14.14	29.8	13.16	28.0	12.22	26.9	11.78	26.1	11.31	24.3	10.42
	-18.8	-19.0	31.5	13.83	29.8	12.89	28.0	11.98	26.9	11.52	26.1	11.07	24.3	10.22
	-16.7	-17.0	31.5	13.20	29.8	12.31	28.0	11.45	26.9	11.02	26.1	10.61	24.3	9.79
	-13.7	-15.0	31.5	12.56	29.8	11.72	28.0	10.90	26.9	10.51	26.1	10.12	24.3	9.35
	-11.8	-13.0	31.5	11.93	29.8	11.14	28.0	10.37	26.9	10.00	26.1	9.62	24.3	8.90
	-9.8	-11.0	31.5	11.30	29.8	10.56	28.0	9.84	26.9	9.48	26.1	9.14	24.3	8.46
	-9.5	-10.0	31.5	10.99	29.8	10.27	28.0	9.58	26.9	9.24	26.1	8.90	24.3	8.23
	-8.5	-9.1	31.5	10.71	29.8	10.03	28.0	9.35	26.9	9.02	26.1	8.69	24.3	8.04
	-7.0	-7.6	31.5	10.27	29.8	9.62	28.0	8.97	26.9	8.66	26.1	8.35	24.3	7.74
	-5.0	-5.6	31.5	9.69	29.8	9.09	28.0	8.49	26.9	8.20	26.1	7.91	24.3	7.33
	-3.0	-3.7	31.5	9.17	29.8	8.61	28.0	8.04	26.9	7.77	26.1	7.50	24.3	6.97
	0.0	-0.7	31.5	8.42	29.8	7.91	28.0	7.41	26.9	7.15	26.1	6.91	24.3	6.44
	3.0	2.2	31.5	7.75	29.8	7.29	28.0	6.83	26.9	6.61	26.1	6.38	24.3	5.96
	5.0	4.1	31.5	7.36	29.8	6.91	28.0	6.49	26.9	6.28	26.1	6.08	24.3	5.67
	7.0	6.0	31.5	6.98	29.8	6.57	28.0	6.18	26.9	5.97	26.1	5.79	24.3	5.41
9.0	7.9	31.5	6.62	29.8	6.25	28.0	5.87	26.9	5.70	26.1	5.51	24.3	5.15	
11.0	9.8	31.5	6.30	29.8	5.94	28.0	5.60	26.9	5.43	26.1	5.25	24.3	4.91	
13.0	11.8	31.5	5.99	29.8	5.65	28.0	5.32	26.9	5.17	26.1	5.00	24.3	4.69	
15.0	13.7	31.5	5.70	29.8	5.39	28.0	5.08	26.9	4.93	26.1	4.78	24.3	4.48	

Abbreviations:

CR: Combination ratio

TC: Total capacity (kW)

PI: Power input (compressor + outdoor fan motor) (kW)

Notes:

1. Shaded cells indicate rating condition.

# VMEX 460V 60Hz

Table 2-8.15: VMEX018Q8A-D33V560 heating capacity

CR	Outdoor air temp.		Indoor air temp. °C DB											
			16.0		18.0		20.0		21.0		22.0		24.0	
	°C DB	°C WB	TC	PI	TC	PI	TC	PI	TC	PI	TC	PI	TC	PI
130%	-19.8	-20.0	40.8	10.80	40.6	11.56	40.4	12.33	40.4	12.71	40.2	13.09	40.2	13.86
	-18.8	-19.0	41.4	11.04	41.2	11.79	41.2	12.55	41.0	12.93	41.0	13.28	40.8	14.04
	-16.7	-17.0	43.0	11.56	42.8	12.27	42.6	13.01	42.6	13.36	42.6	13.72	42.4	14.44
	-13.7	-15.0	44.8	12.09	44.6	12.79	44.4	13.48	44.4	13.82	44.2	14.18	44.2	14.87
	-11.8	-13.0	46.6	12.63	46.6	13.30	46.4	13.96	46.2	14.30	46.2	14.63	46.0	15.29
	-9.8	-11.0	48.8	13.19	48.6	13.82	48.4	14.46	48.4	14.77	48.4	15.09	48.2	15.73
	-9.5	-10.0	50.0	13.46	49.8	14.08	49.6	14.69	49.6	15.01	49.4	15.31	49.4	15.92
	-8.5	-9.1	51.0	13.70	50.8	14.30	50.8	14.91	50.6	15.21	50.6	15.51	50.4	16.12
	-7.0	-7.6	52.8	14.10	52.8	14.69	52.6	15.27	52.6	15.57	52.4	15.85	52.2	16.44
	-5.0	-5.6	55.6	14.63	55.4	15.19	55.2	15.75	55.2	16.02	55.0	16.28	55.0	16.84
	-3.0	-3.7	58.2	15.11	58.0	15.65	58.0	16.16	57.8	16.44	57.8	16.70	57.6	17.22
	0.0	-0.7	62.8	15.85	62.8	16.34	62.6	16.82	62.6	17.00	62.4	17.32	62.4	17.79
	3.0	2.2	67.8	16.50	67.6	16.96	67.4	17.42	67.4	17.63	67.4	17.87	67.2	18.31
	5.0	4.1	71.2	16.92	71.0	17.36	71.0	17.77	70.8	17.99	70.8	18.21	70.6	18.63
	7.0	6.0	74.8	17.32	74.6	17.71	74.6	18.13	74.4	18.33	74.4	18.53	71.4	17.79
	9.0	7.9	78.6	17.67	78.4	18.07	78.4	18.45	78.2	18.65	76.6	18.25	71.4	16.72
11.0	9.8	82.6	18.03	82.4	18.39	82.0	18.63	79.2	17.89	76.6	17.16	71.4	15.75	
13.0	11.8	87.0	18.37	86.8	18.73	82.0	17.45	79.2	16.76	76.6	16.10	71.4	14.77	
15.0	13.7	91.2	18.69	87.2	17.73	82.0	16.44	79.2	15.81	76.6	15.17	71.4	13.94	
120%	-19.8	-20.0	40.6	11.84	40.4	12.53	40.2	13.24	40.2	13.58	40.2	13.94	40.0	14.65
	-18.8	-19.0	41.2	12.05	41.0	12.75	41.0	13.44	40.8	13.78	40.8	14.14	40.6	14.83
	-16.7	-17.0	42.8	12.53	42.6	13.20	42.3	13.86	42.4	14.20	42.4	14.54	42.2	15.19
	-13.7	-15.0	44.6	13.03	44.4	13.66	44.2	14.30	44.2	14.64	44.2	14.95	44.0	15.59
	-11.8	-13.0	46.4	13.52	46.4	14.14	46.2	14.75	46.2	15.07	46.0	15.37	46.0	15.98
	-9.8	-11.0	48.6	14.04	48.4	14.62	48.4	15.21	48.2	15.51	48.2	15.79	48.0	16.38
	-9.5	-10.0	49.8	14.30	49.6	14.87	49.4	15.43	49.4	15.73	49.4	16.01	49.2	16.58
	-8.5	-9.1	50.8	14.51	50.6	15.07	50.6	15.63	50.4	15.91	50.4	16.20	50.2	16.76
	-7.0	-7.6	52.6	14.89	52.6	15.43	52.4	15.96	52.4	16.24	52.2	16.50	52.2	17.04
	-5.0	-5.6	55.4	15.37	55.2	15.89	55.0	16.40	55.0	16.66	55.0	16.92	54.8	17.42
	-3.0	-3.7	58.0	15.83	58.0	16.32	57.8	16.80	57.8	17.04	57.6	17.30	57.6	17.77
	0.0	-0.7	62.6	16.50	62.6	16.96	62.4	17.40	62.4	17.64	62.2	17.85	62.2	18.31
	3.0	2.2	67.6	17.12	67.4	17.53	67.4	17.95	67.2	18.17	67.2	18.37	65.8	18.27
	5.0	4.1	71.0	17.49	70.8	17.89	70.8	18.29	70.6	18.49	70.6	18.69	65.8	17.16
	7.0	6.0	74.6	17.85	74.6	18.23	74.4	18.61	73.2	18.35	70.8	17.59	65.8	16.14
	9.0	7.9	78.4	18.21	78.2	18.57	75.6	17.95	73.2	17.24	70.8	16.54	65.8	15.19
11.0	9.8	82.4	18.53	80.4	18.21	75.6	16.88	73.2	16.22	70.8	15.57	65.8	14.32	
13.0	11.8	85.4	18.35	80.4	17.08	75.6	15.83	73.2	15.23	70.8	14.64	65.8	13.46	
15.0	13.7	85.4	17.28	80.4	16.09	75.6	14.93	73.2	14.36	70.8	13.80	65.8	12.71	
110%	-19.8	-20.0	40.4	12.87	40.2	13.50	40.0	14.16	40.0	14.48	40.0	14.79	39.8	15.45
	-18.8	-19.0	41.0	13.07	40.8	13.70	40.8	14.34	40.8	14.66	40.6	14.97	40.6	15.61
	-16.7	-17.0	42.6	13.50	42.4	14.12	43.0	14.73	42.2	15.03	42.2	15.35	42.0	15.95
	-13.7	-15.0	44.4	13.96	44.2	14.56	44.0	15.13	44.0	15.43	44.0	15.73	43.8	16.30
	-11.8	-13.0	46.2	14.44	46.2	14.99	46.0	15.55	46.0	15.83	45.8	16.11	45.8	16.68
	-9.8	-11.0	48.4	14.89	48.2	15.43	48.2	15.97	48.0	16.24	48.0	16.50	48.0	17.04
	-9.5	-10.0	49.6	15.13	49.4	15.65	49.2	16.18	49.2	16.44	49.2	16.70	49.0	17.22
	-8.5	-9.1	50.6	15.33	50.4	15.85	50.4	16.36	50.2	16.62	50.2	16.88	50.2	17.39
	-7.0	-7.6	52.4	15.69	52.4	16.16	52.2	16.66	52.2	16.92	52.2	17.16	52.0	17.65
	-5.0	-5.6	55.2	16.12	55.0	16.60	54.8	17.06	54.8	17.30	54.8	17.53	54.6	18.01
	-3.0	-3.7	57.8	16.54	57.8	16.98	57.6	17.43	57.6	17.65	57.4	17.87	57.4	18.33
	0.0	-0.7	62.4	17.16	62.4	17.57	62.2	17.99	62.2	18.19	62.2	18.41	60.4	18.05
	3.0	2.2	67.4	17.73	67.2	18.11	67.2	18.49	67.0	18.67	64.8	17.91	60.4	16.42
	5.0	4.1	70.8	18.07	70.8	18.45	69.4	18.27	67.0	17.53	64.8	16.84	60.4	15.45
	7.0	6.0	74.4	18.41	73.8	18.53	69.4	17.16	67.0	16.48	64.8	15.83	60.4	14.54
	9.0	7.9	78.2	18.71	73.8	17.41	69.4	16.14	67.0	15.51	64.8	14.89	60.4	13.70
11.0	9.8	78.2	17.59	73.8	16.38	69.4	15.19	67.0	14.62	64.8	14.04	60.4	12.93	
13.0	11.8	78.2	16.50	73.8	15.37	69.4	14.28	67.0	13.74	64.8	13.21	60.4	12.17	
15.0	13.7	78.2	14.66	73.8	14.50	69.4	13.48	67.0	12.97	64.8	12.49	60.4	11.52	

Abbreviations:

CR: Combination ratio

TC: Total capacity (kW)

PI: Power input (compressor + outdoor fan motor) (kW)

Notes:

1. Shaded cells indicate rating condition.

Table continued on next page ...

Table 2-8.15: VMEX018Q8A-D33V560 heating capacity (continued)

CR	Outdoor air temp.		Indoor air temp. °C DB											
			16.0		18.0		20.0		21.0		22.0		24.0	
	°C DB	°C WB	TC	PI	TC	PI	TC	PI	TC	PI	TC	PI	TC	PI
100%	-19.8	-20.0	40.2	13.90	40.0	14.48	40.0	15.07	39.8	15.37	39.8	15.65	39.6	16.24
	-18.8	-19.0	40.8	14.08	40.8	14.65	40.6	15.23	40.6	15.53	40.4	15.83	40.4	16.40
	-16.7	-17.0	42.4	14.48	42.2	15.03	42.2	15.59	42.0	15.87	42.0	16.14	42.0	16.70
	-13.7	-15.0	44.2	14.89	44.0	15.43	43.8	15.97	43.8	16.24	43.8	16.50	43.6	17.04
	-11.8	-13.0	46.0	15.33	46.0	15.83	45.8	16.34	45.8	16.60	45.8	16.86	45.6	17.38
	-9.8	-11.0	48.2	15.75	48.0	16.24	48.0	16.72	48.0	16.98	47.8	17.22	47.8	17.69
	-9.5	-10.0	49.4	15.97	49.2	16.44	49.2	16.92	49.0	17.16	49.0	17.40	48.8	17.87
	-8.5	-9.1	50.4	16.14	50.2	16.62	50.2	17.08	50.2	17.32	50.0	17.55	50.0	18.01
	-7.0	-7.6	52.2	16.46	52.2	16.92	52.0	17.36	52.0	17.59	52.0	17.81	51.8	18.27
	-5.0	-5.6	55.0	16.88	54.8	17.30	54.8	17.73	54.6	17.93	54.6	18.15	54.4	18.59
	-3.0	-3.7	57.6	17.26	57.6	15.67	57.4	18.07	57.4	18.27	57.4	18.47	55.0	17.69
	0.0	-0.7	62.2	17.81	62.2	18.19	62.0	18.57	61.0	18.27	59.0	17.51	55.0	16.06
	3.0	2.2	67.2	18.33	67.0	18.67	63.0	17.28	61.0	16.60	59.0	15.95	55.0	14.63
	5.0	4.1	70.6	18.67	67.0	17.53	63.0	16.24	61.0	15.63	59.0	15.01	55.0	13.80
	7.0	6.0	71.0	17.71	67.0	16.48	63.0	15.29	61.0	14.71	59.0	14.14	55.0	13.01
9.0	7.9	71.0	16.64	67.0	15.51	63.0	14.40	61.0	13.68	59.0	13.32	55.0	12.27	
11.0	9.8	71.0	15.67	67.0	14.61	63.0	13.58	61.0	13.07	59.0	12.57	55.0	11.60	
13.0	11.8	71.0	14.71	67.0	13.74	63.0	12.79	61.0	12.31	59.0	11.85	55.0	10.94	
15.0	13.7	71.0	13.88	67.0	12.97	63.0	12.07	61.0	11.64	59.0	11.20	55.0	10.37	
90%	-19.8	-20.0	39.9	14.93	39.7	15.45	39.7	15.98	39.5	16.24	39.5	16.52	39.5	17.04
	-18.8	-19.0	40.5	15.09	40.5	15.63	40.3	16.14	40.3	16.40	40.3	16.66	40.1	17.18
	-16.7	-17.0	42.1	15.47	41.9	15.97	41.9	16.46	41.9	16.72	41.7	16.96	41.7	17.45
	-13.7	-15.0	43.9	15.85	43.7	16.32	43.7	16.80	43.5	17.04	43.5	17.28	43.5	17.75
	-11.8	-13.0	45.7	16.22	45.7	16.68	45.5	17.14	45.5	17.38	45.5	17.59	45.3	18.05
	-9.8	-11.0	47.9	16.60	47.9	17.04	47.7	17.47	47.7	17.69	47.7	17.93	47.5	18.37
	-9.5	-10.0	49.1	16.80	48.9	17.24	48.9	17.65	48.7	17.87	48.7	18.09	48.7	18.51
	-8.5	-9.1	50.1	16.98	50.1	17.39	49.9	17.81	49.9	18.01	49.9	18.23	49.3	18.41
	-7.0	-7.6	51.9	17.26	51.9	17.65	51.7	18.07	51.7	18.27	51.7	18.47	49.3	17.57
	-5.0	-5.6	54.7	17.63	54.5	18.01	54.5	18.39	54.3	18.59	52.9	18.01	49.3	16.52
	-3.0	-3.7	57.3	17.97	57.3	18.33	56.7	18.41	54.7	17.67	52.9	16.96	49.3	15.57
	0.0	-0.7	62.1	18.49	60.3	18.03	56.7	16.70	54.7	16.04	52.9	15.41	49.3	14.16
	3.0	2.2	63.9	17.61	60.3	16.40	56.7	15.21	54.7	14.63	52.9	14.06	49.3	12.95
	5.0	4.1	63.9	16.56	60.3	15.43	56.7	14.34	54.7	13.78	52.9	13.26	49.3	12.21
	7.0	6.0	63.9	15.57	60.3	14.54	56.7	13.50	54.7	13.01	52.9	12.51	49.3	11.54
9.0	7.9	63.9	14.67	60.3	13.68	56.7	12.73	54.7	12.27	52.9	11.81	49.3	10.90	
11.0	9.8	63.9	13.82	60.3	12.91	56.7	12.03	54.7	11.60	52.9	11.16	49.3	10.33	
13.0	11.8	63.9	13.01	60.3	12.17	56.7	11.34	54.7	10.94	52.9	10.54	49.3	9.75	
15.0	13.7	63.9	12.29	60.3	11.50	56.7	10.74	54.7	10.36	52.9	9.99	49.3	9.25	
80%	-19.8	-20.0	39.8	15.96	39.6	16.42	39.6	16.90	39.6	17.14	39.4	17.37	39.4	17.83
	-18.8	-19.0	40.4	16.10	40.4	16.58	40.2	17.04	40.2	17.27	40.2	17.49	40.0	17.97
	-16.7	-17.0	42.0	16.44	41.8	16.88	41.8	17.33	41.8	17.55	41.8	17.77	41.6	18.21
	-13.7	-15.0	43.8	16.78	43.6	17.20	43.6	17.63	43.6	17.83	43.4	18.05	43.4	18.49
	-11.8	-13.0	45.6	17.12	45.6	17.53	45.4	17.93	45.4	18.13	45.4	18.35	44.0	17.85
	-9.8	-11.0	47.8	17.45	47.8	17.85	47.6	18.25	47.6	18.43	47.2	18.39	44.0	16.86
	-9.5	-10.0	49.0	17.63	48.8	18.01	48.8	18.39	48.8	18.59	47.2	17.85	44.0	16.36
	-8.5	-9.1	50.0	17.79	46.5	18.17	49.8	18.53	48.8	18.11	47.2	17.37	44.0	15.93
	-7.0	-7.6	51.8	18.05	51.8	18.41	50.4	18.01	48.8	17.29	47.2	16.60	44.0	15.23
	-5.0	-5.6	54.6	18.37	53.6	18.27	50.4	16.92	48.8	16.26	47.2	15.61	44.0	14.34
	-3.0	-3.7	56.8	18.47	53.6	17.20	50.4	15.93	48.8	15.33	47.2	14.71	44.0	13.54
	0.0	-0.7	56.8	16.76	53.6	15.61	50.4	14.50	48.8	13.96	47.2	13.40	44.0	12.35
	3.0	2.2	56.8	15.27	53.6	14.24	50.4	13.24	48.8	12.75	47.2	12.27	44.0	11.32
	5.0	4.1	56.8	14.38	53.6	13.42	50.4	12.49	48.8	12.03	47.2	11.60	44.0	10.70
	7.0	6.0	56.8	13.54	53.6	12.67	50.4	11.79	48.8	11.38	47.2	10.96	44.0	10.13
9.0	7.9	56.8	12.79	53.6	11.95	50.4	11.14	48.8	10.74	47.2	10.37	44.0	9.59	
11.0	9.8	56.8	12.07	53.6	11.30	50.4	10.54	48.8	10.17	47.2	9.81	44.0	9.09	
13.0	11.8	56.8	11.38	53.6	10.66	50.4	9.97	48.8	9.61	47.2	9.27	44.0	8.60	
15.0	13.7	56.8	10.76	53.6	10.11	50.4	9.45	48.8	9.11	47.2	8.80	44.0	8.18	

Abbreviations:

CR: Combination ratio

TC: Total capacity (kW)

PI: Power input (compressor + outdoor fan motor) (kW)

Notes:

1. Shaded cells indicate rating condition.

Table continued on next page ...

# VMEX 460V 60Hz

Table 2-8.15: VMEX018Q8A-D33V560 heating capacity (continued)

CR	Outdoor air temp.		Indoor air temp. °C DB											
			16.0		18.0		20.0		21.0		22.0		24.0	
	°C DB	°C WB	TC	PI	TC	PI	TC	PI	TC	PI	TC	PI	TC	PI
70%	-19.8	-20.0	39.5	17.00	39.3	17.39	39.3	17.81	39.3	18.01	39.3	18.23	38.3	18.03
	-18.8	-19.0	40.1	17.14	40.1	17.53	39.9	17.93	39.9	18.13	39.9	18.35	38.3	17.65
	-16.7	-17.0	41.7	17.41	41.7	17.81	41.5	18.19	41.5	18.39	41.1	16.38	38.3	16.84
	-13.7	-15.0	43.5	17.71	43.3	18.09	43.3	18.47	42.5	18.19	41.1	17.45	38.3	16.00
	-11.8	-13.0	45.3	18.01	45.3	18.37	44.1	17.93	42.5	17.23	41.1	16.54	38.3	15.17
	-9.8	-11.0	47.5	18.31	46.9	18.29	44.1	16.94	42.5	16.28	41.1	15.63	38.3	14.36
	-9.5	-10.0	48.7	18.47	46.9	17.75	44.1	16.44	42.5	15.81	41.1	15.19	38.3	13.96
	-8.5	-9.1	49.7	18.57	46.9	17.27	44.1	16.00	42.5	15.39	41.1	14.79	38.3	13.60
	-7.0	-7.6	49.7	17.73	46.9	16.50	44.1	15.31	42.5	14.73	41.1	14.16	38.3	13.03
	-5.0	-5.6	49.7	16.66	46.9	15.53	44.1	14.42	42.5	13.86	41.1	16.37	38.3	12.29
	-3.0	-3.7	49.7	15.69	46.9	14.63	44.1	13.60	42.5	13.09	41.1	12.59	38.3	11.62
	0.0	-0.7	49.7	14.28	46.9	13.34	44.1	12.41	42.5	11.95	41.1	11.52	38.3	10.64
	3.0	2.2	49.7	13.05	46.9	12.21	44.1	11.38	42.5	10.96	41.1	10.56	38.3	9.77
	5.0	4.1	49.7	12.31	46.9	11.52	44.1	10.76	42.5	10.36	41.1	9.99	38.3	9.25
	7.0	6.0	49.7	11.64	46.9	10.90	44.1	10.17	42.5	9.81	41.1	9.47	38.3	8.78
9.0	7.9	49.7	11.00	46.9	10.31	44.1	9.63	42.5	9.29	41.1	8.97	38.3	8.32	
11.0	9.8	49.7	10.40	46.9	9.75	44.1	9.13	42.5	8.82	41.1	8.52	38.3	7.90	
13.0	11.8	49.7	9.83	46.9	9.23	44.1	8.64	42.5	8.36	41.1	8.06	38.3	7.51	
15.0	13.7	49.7	9.31	46.9	8.76	44.1	8.20	42.5	7.94	41.1	7.66	38.3	7.15	
60%	-19.8	-20.0	39.4	18.03	39.2	18.37	37.8	17.67	36.6	16.98	35.4	16.30	33.0	14.95
	-18.8	-19.0	40.0	18.15	40.0	18.49	37.8	17.29	36.6	16.62	35.4	15.94	33.0	14.63
	-16.7	-17.0	41.6	18.39	40.2	17.81	37.8	16.50	36.6	15.86	35.4	15.23	33.0	14.00
	-13.7	-15.0	42.6	18.19	40.2	16.92	37.8	15.69	36.6	15.09	35.4	14.49	33.0	13.32
	-11.8	-13.0	42.6	17.22	40.2	16.02	37.8	14.87	36.6	14.32	35.4	13.76	33.0	12.73
	-9.8	-11.0	42.6	16.26	40.2	15.15	37.8	14.08	36.6	13.54	35.4	13.03	33.0	12.01
	-9.5	-10.0	42.6	15.81	40.2	14.73	37.8	13.68	36.6	13.18	35.4	12.67	33.0	11.67
	-8.5	-9.1	42.6	15.39	40.2	14.36	37.8	13.34	36.6	12.85	35.4	12.35	33.0	11.40
	-7.0	-7.6	42.6	14.71	40.2	13.74	37.8	12.77	36.6	12.31	35.4	11.83	33.0	10.94
	-5.0	-5.6	42.6	13.86	40.2	12.95	37.8	12.05	36.6	11.62	35.4	11.18	33.0	10.35
	-3.0	-3.7	42.6	13.08	40.2	12.23	37.8	11.40	36.6	11.00	35.4	10.58	33.0	9.79
	0.0	-0.7	42.6	11.95	40.2	11.20	37.8	10.44	36.6	10.09	35.4	9.71	33.0	8.99
	3.0	2.2	42.6	10.96	40.2	10.28	37.8	9.61	36.6	9.27	35.4	8.96	33.0	8.30
	5.0	4.1	42.6	10.37	40.2	9.73	37.8	9.09	36.6	8.80	35.4	8.48	33.0	7.88
	7.0	6.0	42.6	9.81	40.2	9.21	37.8	8.62	36.6	8.34	35.4	8.06	33.0	7.49
9.0	7.9	42.6	9.29	40.2	8.74	37.8	8.18	36.6	7.92	35.4	7.64	33.0	7.13	
11.0	9.8	42.6	8.82	40.2	8.30	37.8	7.78	36.6	7.53	35.4	7.27	33.0	6.79	
13.0	11.8	42.6	8.34	40.2	7.86	37.8	7.39	36.6	7.15	35.4	6.91	33.0	6.45	
15.0	13.7	42.6	7.94	40.2	7.47	37.8	7.03	36.6	6.81	35.4	6.59	33.0	6.16	
50%	-19.8	-20.0	35.5	16.40	33.5	15.27	31.5	14.18	30.3	13.66	29.3	13.12	27.3	12.09
	-18.8	-19.0	35.5	16.04	33.5	14.95	31.5	13.90	30.3	13.36	29.3	12.85	27.3	11.85
	-16.7	-17.0	35.5	15.31	33.5	14.28	31.5	13.28	30.3	12.79	29.3	12.31	27.3	11.36
	-13.7	-15.0	35.5	14.57	33.5	13.60	31.5	12.65	30.3	12.19	29.3	11.73	27.3	10.84
	-11.8	-13.0	35.5	13.84	33.5	12.93	31.5	12.03	30.3	11.60	29.3	11.16	27.3	10.32
	-9.8	-11.0	35.5	13.11	33.5	12.25	31.5	11.42	30.3	11.00	29.3	10.60	27.3	9.81
	-9.5	-10.0	35.5	12.75	33.5	11.91	31.5	11.12	30.3	10.72	29.3	10.32	27.3	9.55
	-8.5	-9.1	35.5	12.43	33.5	11.64	31.5	10.84	30.3	10.46	29.3	10.09	27.3	9.33
	-7.0	-7.6	35.5	11.91	33.5	11.16	31.5	10.40	30.3	10.05	29.3	9.69	27.3	8.97
	-5.0	-5.6	35.5	11.24	33.5	10.54	31.5	9.85	30.3	9.51	29.3	9.17	27.3	8.50
	-3.0	-3.7	35.5	10.64	33.5	9.99	31.5	9.33	30.3	9.01	29.3	8.70	27.3	8.08
	0.0	-0.7	35.5	9.77	33.5	9.17	31.5	8.60	30.3	8.30	29.3	8.02	27.3	7.47
	3.0	2.2	35.5	8.99	33.5	8.46	31.5	7.92	30.3	7.66	29.3	7.41	27.3	6.91
	5.0	4.1	35.5	8.54	33.5	8.02	31.5	7.53	30.3	7.29	29.3	7.05	27.3	6.57
	7.0	6.0	35.5	8.10	33.5	7.62	31.5	7.17	30.3	6.93	29.3	6.71	27.3	6.27
9.0	7.9	35.5	7.68	33.5	7.25	31.5	6.81	30.3	6.61	29.3	6.39	27.3	5.98	
11.0	9.8	35.5	7.31	33.5	6.89	31.5	6.49	30.3	6.29	29.3	6.10	27.3	5.70	
13.0	11.8	35.5	6.95	33.5	6.55	31.5	6.18	30.3	6.00	29.3	5.80	27.3	5.44	
15.0	13.7	35.5	6.61	33.5	6.25	31.5	5.90	30.3	5.72	29.3	5.54	27.3	5.20	

Abbreviations:

CR: Combination ratio

TC: Total capacity (kW)

PI: Power input (compressor + outdoor fan motor) (kW)

Notes:

1. Shaded cells indicate rating condition.



Table 2-8.16: VMEX020Q8A-D36V615 heating capacity

CR	Outdoor air temp.		Indoor air temp. °C DB											
			16.0		18.0		20.0		21.0		22.0		24.0	
	°C DB	°C WB	TC	PI	TC	PI	TC	PI	TC	PI	TC	PI	TC	PI
130%	-19.8	-20.0	44.7	12.09	44.5	12.94	44.3	13.81	44.3	14.23	44.0	14.65	44.0	15.52
	-18.8	-19.0	45.3	12.36	45.1	13.21	45.1	14.05	44.9	14.47	44.9	14.87	44.7	15.72
	-16.7	-17.0	47.1	12.94	46.9	13.74	46.7	14.56	46.7	14.96	46.7	15.36	46.4	16.16
	-13.7	-15.0	49.1	13.54	48.9	14.32	48.6	15.10	48.6	15.47	48.4	15.87	48.4	16.65
	-11.8	-13.0	51.0	14.14	51.0	14.90	50.8	15.63	50.6	16.01	50.6	16.39	50.4	17.12
	-9.8	-11.0	53.5	14.76	53.2	15.47	53.0	16.19	53.0	16.54	53.0	16.90	52.8	17.61
	-9.5	-10.0	54.8	15.07	54.5	15.76	54.3	16.45	54.3	16.81	54.1	17.14	54.1	17.83
	-8.5	-9.1	55.9	15.34	55.6	16.01	55.6	16.70	55.4	17.03	55.4	17.36	55.2	18.05
	-7.0	-7.6	57.8	15.79	57.8	16.45	57.6	17.10	57.6	17.43	57.4	17.74	57.2	18.41
	-5.0	-5.6	60.9	16.39	60.7	17.01	60.5	17.63	60.5	17.94	60.2	18.23	60.2	18.85
	-3.0	-3.7	63.7	16.92	63.5	17.52	63.5	18.10	63.3	18.41	63.3	18.70	63.1	19.28
	0.0	-0.7	68.8	17.74	68.8	18.30	68.6	18.83	68.6	19.03	68.3	19.39	68.3	19.92
	3.0	2.2	74.3	18.48	74.0	18.99	73.8	19.50	73.8	19.74	73.8	20.01	73.6	20.50
	5.0	4.1	78.0	18.94	77.8	19.43	77.8	19.90	77.5	20.14	77.5	20.39	77.3	20.86
	7.0	6.0	81.9	19.39	81.7	19.83	81.7	20.30	81.5	20.52	81.5	20.74	81.2	20.92
9.0	7.9	86.1	19.79	85.9	20.23	85.9	20.65	85.6	20.88	83.9	20.44	83.9	18.72	
11.0	9.8	90.5	20.19	90.2	20.59	89.8	20.86	86.7	20.03	83.9	19.21	83.9	17.63	
13.0	11.8	95.3	20.57	95.1	20.97	89.8	19.54	86.7	18.76	83.9	18.03	83.9	16.54	
15.0	13.7	99.9	20.92	95.5	19.85	89.8	18.41	86.7	17.70	83.9	16.99	83.9	15.61	
120%	-19.8	-20.0	44.5	13.25	44.2	14.03	44.0	14.83	44.0	15.21	44.0	15.61	43.8	16.41
	-18.8	-19.0	45.1	13.50	44.9	14.27	44.9	15.05	44.7	15.43	44.7	15.83	44.5	16.61
	-16.7	-17.0	46.9	14.03	46.7	14.79	46.4	15.52	46.4	15.90	46.4	16.27	46.2	17.01
	-13.7	-15.0	48.9	14.59	48.6	15.30	48.4	16.01	48.4	16.39	48.4	16.74	48.2	17.45
	-11.8	-13.0	50.8	15.14	50.8	15.83	50.6	16.52	50.6	16.87	50.4	17.21	50.4	17.90
	-9.8	-11.0	53.2	15.72	53.0	16.36	53.0	17.03	52.8	17.36	52.8	17.68	52.6	18.34
	-9.5	-10.0	54.5	16.01	54.3	16.65	54.1	17.27	54.1	17.61	54.1	17.92	53.9	18.56
	-8.5	-9.1	55.6	16.25	55.4	16.87	55.4	17.50	55.2	17.81	55.2	18.14	55.0	18.76
	-7.0	-7.6	57.6	16.67	57.6	17.27	57.4	17.87	57.4	18.19	57.2	18.48	57.2	19.08
	-5.0	-5.6	60.7	17.21	60.5	17.79	60.2	18.36	60.2	18.65	60.2	18.94	60.0	19.50
	-3.0	-3.7	63.5	17.72	63.5	18.28	63.3	18.81	63.3	19.08	63.1	19.37	63.1	19.90
	0.0	-0.7	68.6	18.48	68.6	18.99	68.3	19.48	68.3	19.75	68.1	19.99	68.1	20.50
	3.0	2.2	74.0	19.17	73.8	19.63	73.8	20.10	73.6	20.34	73.6	20.57	72.1	20.46
	5.0	4.1	77.8	19.59	77.5	20.03	77.5	20.48	77.3	20.70	77.3	20.92	72.1	19.21
	7.0	6.0	81.7	19.99	81.7	20.41	81.5	20.83	80.2	20.54	77.5	19.70	72.1	18.08
9.0	7.9	85.9	20.39	85.7	20.79	82.8	20.10	80.2	19.30	77.5	18.52	72.1	17.01	
11.0	9.8	90.2	20.74	88.1	20.39	82.8	18.90	80.2	18.16	77.5	17.43	72.1	16.03	
13.0	11.8	93.5	20.54	88.1	19.12	82.8	17.72	80.2	17.05	77.5	16.39	72.1	15.07	
15.0	13.7	93.5	19.34	88.1	18.01	82.8	16.72	80.2	16.07	77.5	15.45	72.1	14.23	
110%	-19.8	-20.0	44.2	14.41	44.0	15.12	43.8	15.85	43.8	16.21	43.8	16.57	43.6	17.30
	-18.8	-19.0	44.9	14.63	44.7	15.34	44.7	16.05	44.7	16.41	44.5	16.76	44.5	17.48
	-16.7	-17.0	46.7	15.12	46.4	15.81	47.1	16.50	46.2	16.83	46.2	17.19	46.0	17.85
	-13.7	-15.0	48.6	15.63	48.4	16.30	48.2	16.94	48.2	17.28	48.2	17.61	48.0	18.25
	-11.8	-13.0	50.6	16.16	50.6	16.79	50.4	17.41	50.4	17.72	50.2	18.03	50.2	18.68
	-9.8	-11.0	53.0	16.68	52.8	17.28	52.8	17.88	52.6	18.19	52.6	18.48	52.6	19.08
	-9.5	-10.0	54.3	16.94	54.1	17.52	53.9	18.12	53.9	18.41	53.9	18.70	53.7	19.28
	-8.5	-9.1	55.4	17.16	55.2	17.74	55.2	18.32	55.0	18.61	55.0	18.90	55.0	19.73
	-7.0	-7.6	57.4	17.57	57.4	18.10	57.2	18.66	57.2	18.94	57.2	19.21	57.0	19.77
	-5.0	-5.6	60.5	18.05	60.2	18.59	60.0	19.10	60.0	19.37	60.0	19.63	59.8	20.17
	-3.0	-3.7	63.3	18.52	63.3	19.01	63.1	19.52	63.1	19.77	62.9	20.01	62.9	20.52
	0.0	-0.7	68.3	19.21	68.3	19.68	68.1	20.14	68.1	20.37	68.1	20.61	66.2	20.21
	3.0	2.2	73.8	19.86	73.6	20.28	73.6	20.70	73.4	20.90	71.0	20.06	66.2	18.39
	5.0	4.1	77.5	20.23	77.5	20.65	76.0	20.46	73.4	19.63	71.0	18.85	66.2	17.30
	7.0	6.0	81.5	20.61	80.8	20.75	76.0	19.21	73.4	18.45	71.0	17.72	66.2	16.28
9.0	7.9	85.6	20.95	80.8	19.50	76.0	18.08	73.4	17.36	71.0	16.68	66.2	15.34	
11.0	9.8	85.6	19.70	80.8	18.34	76.0	17.01	73.4	16.37	71.0	15.72	66.2	14.48	
13.0	11.8	85.6	18.48	80.8	17.21	76.0	15.99	73.4	15.39	71.0	14.79	66.2	13.63	
15.0	13.7	85.6	16.41	80.8	16.23	76.0	15.10	73.4	14.52	71.0	13.99	66.2	12.90	

Abbreviations:

CR: Combination ratio

TC: Total capacity (kW)

PI: Power input (compressor + outdoor fan motor) (kW)

Notes:

1. Shaded cells indicate rating condition.

Table continued on next page ...

# VMEX 460V 60Hz

Table 2-8.16: VMEX020Q8A-D36V615 heating capacity (continued)

CR	Outdoor air temp.		Indoor air temp. °C DB											
			16.0		18.0		20.0		21.0		22.0		24.0	
	°C DB	°C WB	TC	PI	TC	PI	TC	PI	TC	PI	TC	PI	TC	PI
100%	-19.8	-20.0	44.0	15.56	43.8	16.21	43.8	16.88	43.6	17.21	43.6	17.52	43.4	18.19
	-18.8	-19.0	44.7	15.76	44.7	16.41	44.5	17.05	44.5	17.39	44.2	17.72	44.2	18.36
	-16.7	-17.0	46.4	16.21	46.2	16.83	46.2	17.45	46.0	17.77	46.0	18.08	46.0	18.70
	-13.7	-15.0	48.4	16.67	48.2	17.28	48.0	17.88	48.0	18.19	48.0	18.48	47.8	19.08
	-11.8	-13.0	50.4	17.16	50.4	17.72	50.2	18.30	50.2	18.59	50.2	18.88	49.9	19.46
	-9.8	-11.0	52.8	17.63	52.6	18.19	52.6	18.72	52.6	19.01	52.4	19.28	52.4	19.81
	-9.5	-10.0	54.1	17.88	53.9	18.41	53.9	18.94	53.7	19.21	53.7	19.48	53.4	20.01
	-8.5	-9.1	55.2	18.08	55.0	18.61	55.0	19.12	55.0	19.39	54.8	19.66	54.8	20.17
	-7.0	-7.6	57.2	18.43	57.2	18.94	57.0	19.43	57.0	19.70	57.0	19.94	56.7	20.45
	-5.0	-5.6	60.2	18.90	60.0	19.37	60.0	19.85	59.8	20.08	59.8	20.32	59.6	20.81
	-3.0	-3.7	63.1	19.32	63.1	17.54	62.9	20.23	62.9	20.45	62.9	20.68	60.2	19.81
	0.0	-0.7	68.1	19.94	68.1	20.37	67.9	20.79	66.8	20.45	64.6	19.61	60.2	17.99
	3.0	2.2	73.6	20.52	73.4	20.90	69.0	19.34	66.8	18.59	64.6	17.85	60.2	16.39
	5.0	4.1	77.3	20.90	73.4	19.63	69.0	18.19	66.8	17.50	64.6	16.81	60.2	15.45
	7.0	6.0	77.8	19.83	73.4	18.45	69.0	17.12	66.8	16.47	64.6	15.83	60.2	14.56
	9.0	7.9	77.8	18.63	73.4	17.36	69.0	16.12	66.8	15.32	64.6	14.92	60.2	13.74
11.0	9.8	77.8	17.54	73.4	16.36	69.0	15.21	66.8	14.63	64.6	14.07	60.2	12.98	
13.0	11.8	77.8	16.47	73.4	15.39	69.0	14.32	66.8	13.79	64.6	13.27	60.2	12.25	
15.0	13.7	77.8	15.54	73.4	14.52	69.0	13.52	66.8	13.03	64.6	12.54	60.2	11.61	
90%	-19.8	-20.0	43.7	16.72	43.5	17.30	43.5	17.90	43.3	18.19	43.3	18.50	43.3	19.08
	-18.8	-19.0	44.4	16.90	44.4	17.50	44.2	18.08	44.2	18.36	44.2	18.65	43.9	19.23
	-16.7	-17.0	46.1	17.32	45.9	17.88	45.9	18.43	45.9	18.72	45.7	18.99	45.7	19.54
	-13.7	-15.0	48.1	17.74	47.9	18.28	47.9	18.81	47.7	19.08	47.7	19.34	47.7	19.88
	-11.8	-13.0	50.1	18.17	50.1	18.68	49.9	19.19	49.9	19.45	49.9	19.70	49.6	20.21
	-9.8	-11.0	52.5	18.59	52.5	19.08	52.3	19.57	52.3	19.81	52.3	20.08	52.0	20.57
	-9.5	-10.0	53.8	18.81	53.6	19.30	53.6	19.77	53.4	20.01	53.4	20.25	53.4	20.72
	-8.5	-9.1	54.9	19.01	54.9	19.48	54.7	19.94	54.7	20.17	54.7	20.41	54.0	20.61
	-7.0	-7.6	56.9	19.32	56.9	19.77	56.6	20.23	56.6	20.45	56.6	20.68	54.0	19.68
	-5.0	-5.6	59.9	19.74	59.7	20.17	59.7	20.59	59.5	20.81	57.9	20.17	54.0	18.50
	-3.0	-3.7	62.8	20.12	62.8	20.52	62.1	20.61	59.9	19.79	57.9	18.99	54.0	17.43
	0.0	-0.7	68.0	20.70	66.0	20.19	62.1	18.70	59.9	17.96	57.9	17.25	54.0	15.85
	3.0	2.2	70.0	19.72	66.0	18.36	62.1	17.03	59.9	16.39	57.9	15.74	54.0	14.50
	5.0	4.1	70.0	18.54	66.0	17.27	62.1	16.05	59.9	15.43	57.9	14.85	54.0	13.67
	7.0	6.0	70.0	17.43	66.0	16.28	62.1	15.12	59.9	14.56	57.9	14.01	54.0	12.92
	9.0	7.9	70.0	16.43	66.0	15.32	62.1	14.25	59.9	13.74	57.9	13.23	54.0	12.21
11.0	9.8	70.0	15.47	66.0	14.45	62.1	13.47	59.9	12.98	57.9	12.50	54.0	11.56	
13.0	11.8	70.0	14.56	66.0	13.63	62.1	12.70	59.9	12.25	57.9	11.81	54.0	10.92	
15.0	13.7	70.0	13.76	66.0	12.87	62.1	12.03	59.9	11.61	57.9	11.18	54.0	10.36	
80%	-19.8	-20.0	43.6	17.87	43.4	18.39	43.4	18.92	43.4	19.19	43.1	19.45	43.1	19.97
	-18.8	-19.0	44.2	18.03	44.2	18.56	44.0	19.08	44.0	19.34	44.0	19.59	43.8	20.12
	-16.7	-17.0	46.0	18.41	45.8	18.90	45.8	19.41	45.8	19.65	45.8	19.90	45.6	20.39
	-13.7	-15.0	48.0	18.79	47.8	19.25	47.8	19.74	47.8	19.97	47.5	20.21	47.5	20.70
	-11.8	-13.0	49.9	19.17	49.9	19.63	49.7	20.08	49.7	20.30	49.7	20.54	48.2	19.99
	-9.8	-11.0	52.4	19.54	52.4	19.99	52.1	20.43	52.1	20.63	51.7	20.59	48.2	18.88
	-9.5	-10.0	53.7	19.74	53.4	20.16	53.5	20.59	53.5	20.81	51.7	19.99	48.2	18.32
	-8.5	-9.1	54.8	19.92	50.9	20.34	54.5	20.74	53.5	20.28	51.7	19.45	48.2	17.83
	-7.0	-7.6	56.7	20.21	56.7	20.61	55.2	20.16	53.5	19.36	51.7	18.59	48.2	17.05
	-5.0	-5.6	59.8	20.56	58.7	20.45	55.2	18.94	53.5	18.21	51.7	17.47	48.2	16.05
	-3.0	-3.7	62.2	20.68	58.7	19.25	55.2	17.83	53.5	17.16	51.7	16.47	48.2	15.16
	0.0	-0.7	62.2	18.76	58.7	17.47	55.2	16.23	53.5	15.63	51.7	15.01	48.2	13.83
	3.0	2.2	62.2	17.10	58.7	15.94	55.2	14.83	53.5	14.27	51.7	13.74	48.2	12.67
	5.0	4.1	62.2	16.10	58.7	15.03	55.2	13.98	53.5	13.47	51.7	12.98	48.2	11.98
	7.0	6.0	62.2	15.16	58.7	14.18	55.2	13.21	53.5	12.74	51.7	12.27	48.2	11.34
	9.0	7.9	62.2	14.32	58.7	13.38	55.2	12.47	53.5	12.03	51.7	11.61	48.2	10.74
11.0	9.8	62.2	13.52	58.7	12.65	55.2	11.81	53.5	11.38	51.7	10.98	48.2	10.18	
13.0	11.8	62.2	12.74	58.7	11.94	55.2	11.16	53.5	10.76	51.7	10.38	48.2	9.63	
15.0	13.7	62.2	12.05	58.7	11.32	55.2	10.58	53.5	10.20	51.7	9.85	48.2	9.16	

Abbreviations:

CR: Combination ratio

TC: Total capacity (kW)

PI: Power input (compressor + outdoor fan motor) (kW)

Notes:

1. Shaded cells indicate rating condition.

Table continued on next page ...

Table 2-8.16: VMEX020Q8A-D36V615 heating capacity (continued)

CR	Outdoor air temp.		Indoor air temp. °C DB											
			16.0		18.0		20.0		21.0		22.0		24.0	
	°C DB	°C WB	TC	PI	TC	PI	TC	PI	TC	PI	TC	PI	TC	PI
70%	-19.8	-20.0	43.3	19.03	43.1	19.48	43.1	19.94	43.1	20.17	43.1	20.41	42.0	20.19
	-18.8	-19.0	43.9	19.19	43.9	19.63	43.7	20.08	43.7	20.30	43.7	20.54	42.0	19.76
	-16.7	-17.0	45.7	19.50	45.7	19.94	45.5	20.37	45.5	20.59	45.0	18.34	42.0	18.85
	-13.7	-15.0	47.6	19.83	47.4	20.25	47.4	20.68	46.6	20.37	45.0	19.54	42.0	17.92
	-11.8	-13.0	49.6	20.17	49.6	20.56	48.3	20.08	46.6	19.30	45.0	18.52	42.0	16.99
	-9.8	-11.0	52.0	20.50	51.4	20.48	48.3	18.96	46.6	18.23	45.0	17.50	42.0	16.07
	-9.5	-10.0	53.3	20.68	51.4	19.88	48.3	18.41	46.6	17.70	45.0	17.01	42.0	15.63
	-8.5	-9.1	54.4	20.79	51.4	19.34	48.3	17.92	46.6	17.23	45.0	16.56	42.0	15.23
	-7.0	-7.6	54.4	19.85	51.4	18.47	48.3	17.14	46.6	16.50	45.0	15.85	42.0	14.59
	-5.0	-5.6	54.4	18.65	51.4	17.39	48.3	16.14	46.6	15.52	45.0	15.33	42.0	13.76
	-3.0	-3.7	54.4	17.56	51.4	16.39	48.3	15.23	46.6	14.65	45.0	14.10	42.0	13.01
	0.0	-0.7	54.4	15.99	51.4	14.94	48.3	13.90	46.6	13.38	45.0	12.89	42.0	11.92
	3.0	2.2	54.4	14.61	51.4	13.67	48.3	12.74	46.6	12.27	45.0	11.83	42.0	10.94
	5.0	4.1	54.4	13.78	51.4	12.89	48.3	12.05	46.6	11.61	45.0	11.18	42.0	10.36
	7.0	6.0	54.4	13.03	51.4	12.21	48.3	11.38	46.6	10.98	45.0	10.60	42.0	9.83
9.0	7.9	54.4	12.32	51.4	11.54	48.3	10.78	46.6	10.41	45.0	10.05	42.0	9.32	
11.0	9.8	54.4	11.65	51.4	10.92	48.3	10.23	46.6	9.87	45.0	9.54	42.0	8.85	
13.0	11.8	54.4	11.01	51.4	10.34	48.3	9.67	46.6	9.36	45.0	9.03	42.0	8.40	
15.0	13.7	54.4	10.43	51.4	9.80	48.3	9.18	46.6	8.89	45.0	8.58	42.0	8.00	
60%	-19.8	-20.0	43.2	20.19	42.9	20.56	41.4	19.79	40.1	19.01	38.8	18.25	36.1	16.74
	-18.8	-19.0	43.8	20.32	43.8	20.70	41.4	19.36	40.1	18.61	38.8	17.85	36.1	16.39
	-16.7	-17.0	45.6	20.59	44.0	19.94	41.4	18.47	40.1	17.76	38.8	17.05	36.1	15.67
	-13.7	-15.0	46.7	20.36	44.0	18.94	41.4	17.56	40.1	16.90	38.8	16.23	36.1	14.92
	-11.8	-13.0	46.7	19.28	44.0	17.94	41.4	16.65	40.1	16.03	38.8	15.41	36.1	14.25
	-9.8	-11.0	46.7	18.21	44.0	16.96	41.4	15.76	40.1	15.16	38.8	14.58	36.1	13.45
	-9.5	-10.0	46.7	17.70	44.0	16.50	41.4	15.32	40.1	14.76	38.8	14.18	36.1	13.07
	-8.5	-9.1	46.7	17.23	44.0	16.07	41.4	14.94	40.1	14.38	38.8	13.83	36.1	12.76
	-7.0	-7.6	46.7	16.47	44.0	15.39	41.4	14.30	40.1	13.78	38.8	13.25	36.1	12.25
	-5.0	-5.6	46.7	15.52	44.0	14.50	41.4	13.49	40.1	13.01	38.8	12.52	36.1	11.58
	-3.0	-3.7	46.7	14.65	44.0	13.70	41.4	12.76	40.1	12.32	38.8	11.85	36.1	10.96
	0.0	-0.7	46.7	13.38	44.0	12.54	41.4	11.69	40.1	11.29	38.8	10.87	36.1	10.07
	3.0	2.2	46.7	12.27	44.0	11.52	41.4	10.76	40.1	10.38	38.8	10.03	36.1	9.29
	5.0	4.1	46.7	11.61	44.0	10.89	41.4	10.18	40.1	9.85	38.8	9.49	36.1	8.83
	7.0	6.0	46.7	10.98	44.0	10.32	41.4	9.65	40.1	9.34	38.8	9.03	36.1	8.38
9.0	7.9	46.7	10.40	44.0	9.78	41.4	9.16	40.1	8.87	38.8	8.56	36.1	7.98	
11.0	9.8	46.7	9.87	44.0	9.29	41.4	8.71	40.1	8.43	38.8	8.14	36.1	7.60	
13.0	11.8	46.7	9.34	44.0	8.80	41.4	8.27	40.1	8.00	38.8	7.74	36.1	7.23	
15.0	13.7	46.7	8.89	44.0	8.36	41.4	7.87	40.1	7.63	38.8	7.38	36.1	6.89	
50%	-19.8	-20.0	38.9	18.36	36.7	17.10	34.5	15.87	33.2	15.30	32.1	14.70	29.9	13.54
	-18.8	-19.0	38.9	17.96	36.7	16.74	34.5	15.56	33.2	14.96	32.1	14.38	29.9	13.27
	-16.7	-17.0	38.9	17.14	36.7	15.99	34.5	14.87	33.2	14.32	32.1	13.78	29.9	12.72
	-13.7	-15.0	38.9	16.32	36.7	15.23	34.5	14.16	33.2	13.65	32.1	13.14	29.9	12.14
	-11.8	-13.0	38.9	15.50	36.7	14.47	34.5	13.47	33.2	12.98	32.1	12.49	29.9	11.56
	-9.8	-11.0	38.9	14.67	36.7	13.72	34.5	12.78	33.2	12.32	32.1	11.87	29.9	10.98
	-9.5	-10.0	38.9	14.27	36.7	13.34	34.5	12.45	33.2	12.01	32.1	11.56	29.9	10.69
	-8.5	-9.1	38.9	13.92	36.7	13.03	34.5	12.14	33.2	11.72	32.1	11.29	29.9	10.45
	-7.0	-7.6	38.9	13.34	36.7	12.49	34.5	11.65	33.2	11.25	32.1	10.85	29.9	10.05
	-5.0	-5.6	38.9	12.58	36.7	11.81	34.5	11.03	33.2	10.65	32.1	10.27	29.9	9.52
	-3.0	-3.7	38.9	11.92	36.7	11.18	34.5	10.45	33.2	10.09	32.1	9.74	29.9	9.05
	0.0	-0.7	38.9	10.94	36.7	10.27	34.5	9.63	33.2	9.29	32.1	8.98	29.9	8.36
	3.0	2.2	38.9	10.07	36.7	9.47	34.5	8.87	33.2	8.58	32.1	8.29	29.9	7.74
	5.0	4.1	38.9	9.56	36.7	8.98	34.5	8.43	33.2	8.16	32.1	7.89	29.9	7.36
	7.0	6.0	38.9	9.07	36.7	8.54	34.5	8.03	33.2	7.76	32.1	7.51	29.9	7.03
9.0	7.9	38.9	8.60	36.7	8.11	34.5	7.63	33.2	7.40	32.1	7.16	29.9	6.69	
11.0	9.8	38.9	8.18	36.7	7.71	34.5	7.27	33.2	7.05	32.1	6.83	29.9	6.38	
13.0	11.8	38.9	7.78	36.7	7.34	34.5	6.91	33.2	6.71	32.1	6.49	29.9	6.09	
15.0	13.7	38.9	7.40	36.7	7.00	34.5	6.60	33.2	6.40	32.1	6.20	29.9	5.83	

Abbreviations:

CR: Combination ratio

TC: Total capacity (kW)

PI: Power input (compressor + outdoor fan motor) (kW)

Notes:

1. Shaded cells indicate rating condition.

### 8.3 Capacity Correction Factors for Piping Length and Level Difference

VMEX008Q8A-D13V224 / VMEX009Q8A-D16V280 /VMEX010Q8A-D20V335

Figure 2-8.1: VMEX008(009,010)Q8A rate of change in cooling capacity

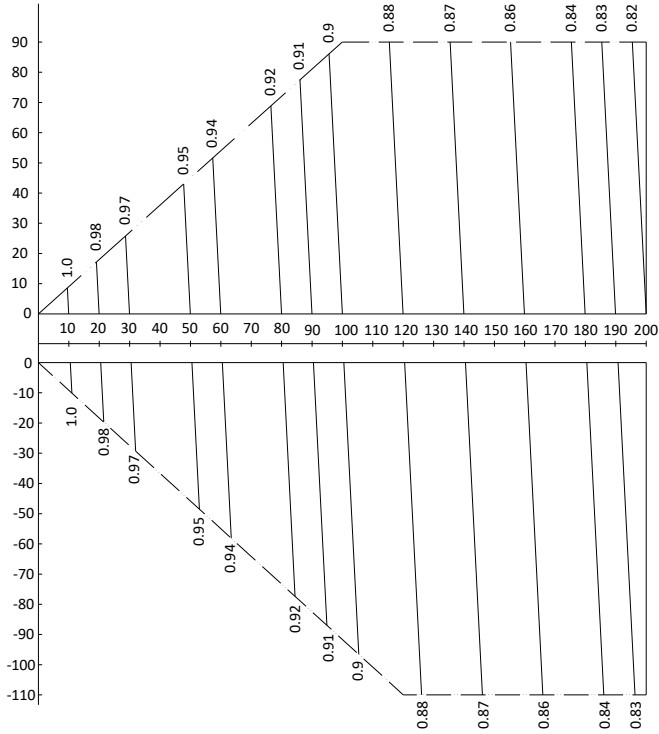
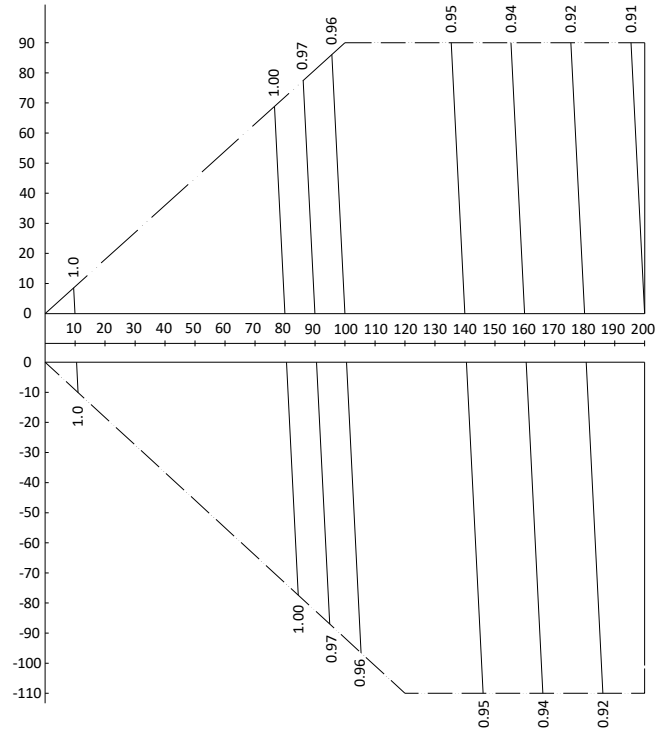

Figure 2-8.2: VMEX008(009,010)Q8A rate of change in heating capacity



Notes:

1. The horizontal axis shows equivalent length of piping between farthest indoor unit and first outdoor branch joint; the vertical axis shows the largest level difference between indoor unit and outdoor unit. For level differences, positive values indicate that the outdoor unit is above the indoor unit, negative values indicate that the outdoor unit is below the indoor unit.
2. These figures illustrate the rate of change in capacity of a system with only standard indoor units at maximum load (with the thermostat set to maximum) under standard conditions. Under partial load conditions there is only a minor deviation from the rate of change in capacity shown in these figures.
3. The capacity of the system is either the total capacity of the indoor units obtained from indoor unit capacity tables or the corrected capacity of the outdoor units as per the calculations below, whichever is smaller.

Corrected capacity of outdoor units	=	Capacity of outdoor units obtained from outdoor unit capacity tables at the combination ratio	x	Capacity correction factor
-------------------------------------	---	---	---	----------------------------

VMEX012Q8A-D23V400 / VMEX014Q8A-D26V450/ VMEX016Q8A-D29V500

Figure 2-8.3: VMEX012(014,016)Q8A rate of change in cooling capacity

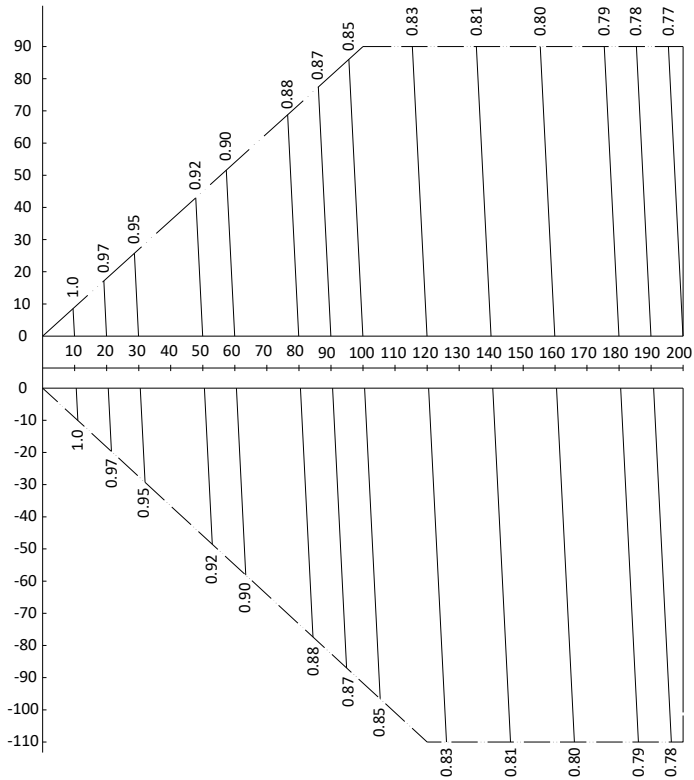
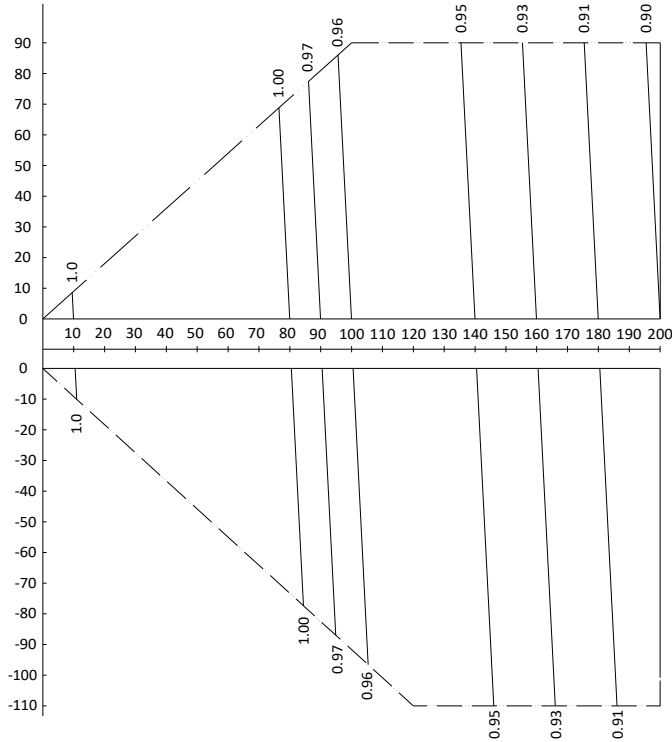

Figure 2-8.4: VMEX012(014,016)Q8A rate of change in heating capacity



Notes:

1. The horizontal axis shows equivalent length of piping between farthest indoor unit and first outdoor branch joint; the vertical axis shows the largest level difference between indoor unit and outdoor unit. For level differences, positive values indicate that the outdoor unit is above the indoor unit, negative values indicate that the outdoor unit is below the indoor unit.
2. These figures illustrate the rate of change in capacity of a system with only standard indoor units at maximum load (with the thermostat set to maximum) under standard conditions. Under partial load conditions there is only a minor deviation from the rate of change in capacity shown in these figures.
3. The capacity of the system is either the total capacity of the indoor units obtained from indoor unit capacity tables or the corrected capacity of the outdoor units as per the calculations below, whichever is smaller.

Corrected capacity of outdoor units	=	Capacity of outdoor units obtained from outdoor unit capacity tables at the combination ratio	x	Capacity correction factor
-------------------------------------	---	---	---	----------------------------

# VMEX 460V 60Hz

## VMEX018Q8A-D33V560/ VMEX020Q8A-D36V615

Figure 2-8.5: VMEX018(020)Q8A rate of change in cooling capacity

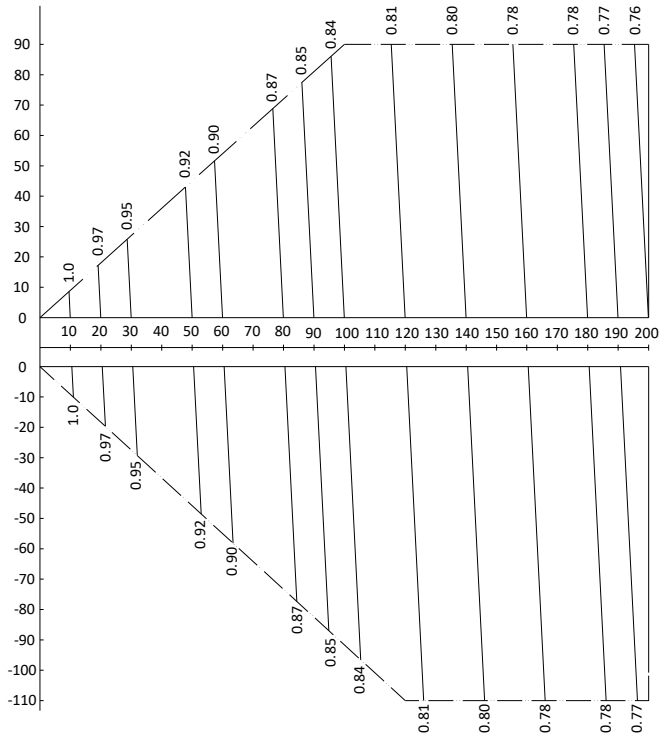
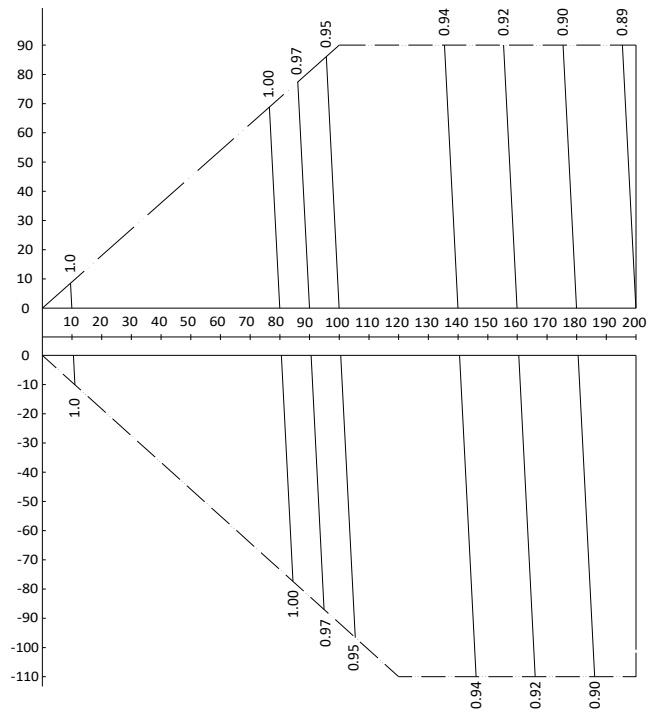

Figure 2-8.6: VMEX018(020)Q8A rate of change in heating capacity



Notes:

1. The horizontal axis shows equivalent length of piping between farthest indoor unit and first outdoor branch joint; the vertical axis shows the largest level difference between indoor unit and outdoor unit. For level differences, positive values indicate that the outdoor unit is above the indoor unit, negative values indicate that the outdoor unit is below the indoor unit.
2. These figures illustrate the rate of change in capacity of a system with only standard indoor units at maximum load (with the thermostat set to maximum) under standard conditions. Under partial load conditions there is only a minor deviation from the rate of change in capacity shown in these figures.
3. The capacity of the system is either the total capacity of the indoor units obtained from indoor unit capacity tables or the corrected capacity of the outdoor units as per the calculations below, whichever is smaller.

Corrected capacity of outdoor units	=	Capacity of outdoor unit capacity tables at the combination ratio	x	Capacity correction factor
-------------------------------------	---	---	---	----------------------------

### 8.4 Capacity Correction Factors for Frost Accumulation

The heating capacity tables do not take account of the reduction in capacity when frost has accumulated or while the defrosting operation is in progress. If snow has accumulated against the outside surface of the outdoor unit heat exchanger heating capacity is reduced. The reduction in heating capacity is dependent on a number of factors including the outdoor temperature, the relative humidity and the amount of frosting which has occurred.

Corrected heating capacity values, which take these factors into account, can be calculated as follows, using the correction factors for frost accumulation given in Table 2-8.17:

Corrected heating capacity = Value given in outdoor heating capacity table × Correction factor for frost accumulation

Table 2-8.17: Correction factor for frost accumulation

<b>Heat exchanger inlet port temperature (°C / RH 85%)</b>	-7	-5	-2	0	2	5	7
<b>Correction factor for frost accumulation</b>	0.94	0.93	0.89	0.84	0.83	0.91	1.00

Corrected heating capacities express the heating capacity over the heating/defrosting cycle shown in Figure 2-8.43.

Figure 2-8.43: Defrosting cycle

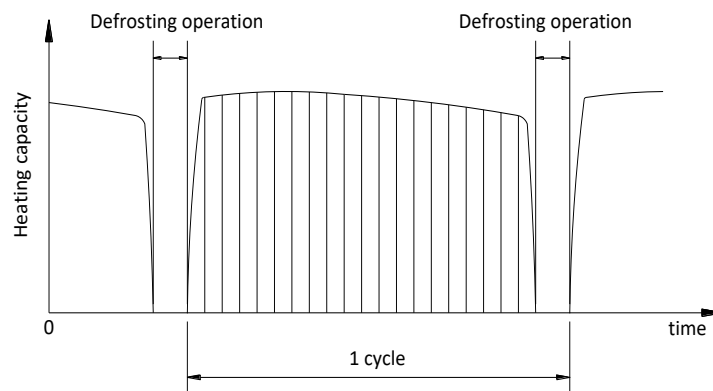

# VMEX 460V 60Hz

## 8.5 Cooling Part Load Performance at 100% Combination Ratio

Table 2-8.18: VMEX008Q8A-D13V224 cooling part load performance

Part load	Outdoor air temp. (°C DB)	Indoor air temp. (°C WB)													
		14.0		16.0		18.0		19.0		20.0		22.0		24.0	
		TC kW	PI kW	TC kW	PI kW	TC kW	PI kW	TC kW	PI kW	TC kW	PI kW	TC kW	PI kW	TC kW	PI kW
100%	10	17.0	1.85	20.3	2.24	23.6	2.65	25.2	2.87	26.8	3.08	30.1	3.53	31.9	3.65
	12	17.0	1.88	20.3	2.28	23.6	2.70	25.2	2.92	26.8	3.14	30.1	3.59	31.4	3.68
	14	17.0	1.91	20.3	2.33	23.6	2.75	25.2	2.98	26.8	3.20	30.1	3.66	31.0	3.72
	16	17.0	1.95	20.3	2.37	23.6	2.81	25.2	3.03	26.8	3.27	30.0	3.71	30.6	3.76
	18	17.0	1.99	20.3	2.41	23.6	2.86	25.2	3.09	26.8	3.33	29.6	3.83	30.2	3.86
	20	17.0	2.02	20.3	2.46	23.6	2.95	25.2	3.25	26.8	3.57	29.2	4.01	29.8	4.05
	21	17.0	2.04	20.3	2.48	23.6	3.06	25.2	3.37	26.8	3.69	29.0	4.10	29.6	4.14
	23	17.0	2.09	20.3	2.65	23.6	3.27	25.2	3.60	26.8	3.96	28.6	4.29	29.2	4.33
	25	17.0	2.23	20.3	2.83	23.6	3.50	25.2	3.86	26.8	4.24	28.2	4.48	28.8	4.51
	27	17.0	2.38	20.3	3.02	23.6	3.74	25.2	4.13	26.8	4.54	27.7	4.67	28.4	4.71
	29	17.0	2.54	20.3	3.22	23.6	3.99	25.2	4.41	26.7	4.82	27.4	4.86	28.0	4.90
	31	17.0	2.70	20.3	3.44	23.6	4.26	25.2	4.71	26.4	5.01	26.9	5.05	27.5	5.09
	33	17.0	2.87	20.3	3.66	23.6	4.54	25.2	5.03	25.9	5.19	26.6	5.24	27.2	5.29
	35	17.0	3.05	20.3	3.89	23.6	4.85	25.2	5.36	25.5	5.38	26.1	5.43	26.7	5.48
	37	17.0	3.24	20.3	4.15	23.6	5.16	24.7	5.55	25.1	5.58	25.7	5.63	26.3	5.67
	39	17.0	3.45	20.3	4.41	23.6	5.50	24.4	5.74	24.7	5.76	25.3	5.82	25.9	5.87
	43	17.0	3.77	20.3	4.73	23.6	5.80	23.6	5.84	24.3	5.91	25.0	5.99	25.1	6.06
	46	17.0	4.01	20.3	4.99	23.6	5.90	23.1	5.94	24.2	6.05	24.8	6.09	24.6	6.17
48	17.0	4.16	20.3	5.12	23.6	5.91	22.2	5.99	24.1	6.12	23.3	6.15	24.0	6.20	
75%	10	12.7	1.36	15.1	1.65	17.6	1.91	18.8	2.02	20.1	2.13	22.5	2.32	25.0	2.47
	12	12.7	1.39	15.1	1.68	17.6	1.93	18.8	2.05	20.1	2.16	22.5	2.34	25.0	2.50
	14	12.7	1.42	15.1	1.71	17.6	1.96	18.8	2.08	20.1	2.18	22.5	2.37	25.0	2.52
	16	12.7	1.44	15.1	1.74	17.6	1.99	18.8	2.11	20.1	2.21	22.5	2.39	25.0	2.54
	18	12.7	1.47	15.1	1.76	17.6	2.02	18.8	2.13	20.1	2.24	22.5	2.42	25.0	2.56
	20	12.7	1.50	15.1	1.80	17.6	2.05	18.8	2.16	20.1	2.26	22.5	2.45	25.0	2.66
	21	12.7	1.52	15.1	1.81	17.6	2.07	18.8	2.18	20.1	2.28	22.5	2.51	25.0	2.73
	23	12.7	1.54	15.1	1.84	17.6	2.13	18.8	2.27	20.1	2.41	22.5	2.66	25.0	2.90
	25	12.7	1.58	15.1	1.93	17.6	2.26	18.8	2.41	20.1	2.55	22.5	2.82	25.0	3.06
	27	12.7	1.68	15.1	2.05	17.6	2.39	18.8	2.55	20.1	2.70	22.5	2.98	25.0	3.23
	29	12.7	1.78	15.1	2.18	17.6	2.53	18.8	2.70	20.1	2.85	22.5	3.15	25.0	3.40
	31	12.7	1.90	15.1	2.30	17.6	2.68	18.8	2.85	20.1	3.01	22.5	3.32	25.0	3.59
	33	12.7	2.01	15.1	2.43	17.6	2.82	18.8	3.00	20.1	3.17	22.5	3.49	25.0	3.76
	35	12.7	2.13	15.1	2.57	17.6	2.98	18.8	3.16	20.1	3.34	22.5	3.67	25.0	3.95
	37	12.7	2.25	15.1	2.71	17.6	3.13	18.8	3.33	20.1	3.51	22.5	3.85	24.7	4.14
	39	12.7	2.38	15.1	2.86	17.6	3.30	18.8	3.50	20.1	3.69	22.5	4.04	24.3	4.33
	43	12.7	2.60	15.1	3.17	17.6	3.63	18.8	3.85	20.1	4.05	22.5	4.43	24.0	4.51
	46	12.7	2.73	15.1	3.28	17.6	3.73	18.8	3.96	20.1	4.17	22.5	4.56	23.7	4.60
48	12.7	2.87	15.1	3.42	17.6	3.86	18.8	4.09	20.1	4.32	22.5	4.72	23.2	4.79	
50%	10	9.1	1.00	10.1	1.00	11.8	1.02	12.5	1.14	13.3	1.26	15.0	1.48	16.6	1.67
	12	8.9	1.00	10.1	1.00	11.8	1.05	12.5	1.17	13.3	1.29	15.0	1.50	16.6	1.69
	14	8.8	1.00	10.1	1.00	11.8	1.08	12.5	1.20	13.3	1.32	15.0	1.54	16.6	1.72
	16	8.7	1.00	10.1	1.00	11.8	1.11	12.5	1.23	13.3	1.35	15.0	1.57	16.6	1.75
	18	8.5	1.00	10.1	1.00	11.8	1.14	12.5	1.27	13.3	1.38	15.0	1.59	16.6	1.78
	20	8.4	1.00	10.1	1.00	11.8	1.17	12.5	1.30	13.3	1.42	15.0	1.63	16.6	1.81
	21	8.4	1.00	10.1	1.00	11.8	1.19	12.5	1.31	13.3	1.43	15.0	1.65	16.6	1.82
	23	8.4	1.00	10.1	1.00	11.8	1.22	12.5	1.35	13.3	1.46	15.0	1.67	16.6	1.86
	25	8.4	1.00	10.1	1.00	11.8	1.25	12.5	1.38	13.3	1.52	15.0	1.76	16.6	1.97
	27	8.4	1.00	10.1	1.03	11.8	1.34	12.5	1.48	13.3	1.62	15.0	1.87	16.6	2.10
	29	8.4	1.04	10.1	1.11	11.8	1.43	12.5	1.58	13.3	1.73	15.0	1.99	16.6	2.22
	31	8.4	1.08	10.1	1.19	11.8	1.53	12.5	1.69	13.3	1.84	15.0	2.11	16.6	2.35
	33	8.4	1.12	10.1	1.28	11.8	1.63	12.5	1.80	13.3	1.95	15.0	2.23	16.6	2.48
	35	8.4	1.16	10.1	1.37	11.8	1.74	12.5	1.91	13.3	2.07	15.0	2.36	16.6	2.61
	37	8.4	1.21	10.1	1.47	11.8	1.85	12.5	2.03	13.3	2.19	15.0	2.49	16.6	2.75
	39	8.4	1.25	10.1	1.57	11.8	1.97	12.5	2.15	13.3	2.32	15.0	2.63	16.6	2.89
	43	8.4	1.38	10.1	1.73	11.8	2.17	12.5	2.37	13.3	2.55	15.0	2.88	16.6	3.21
	46	8.4	1.41	10.1	1.77	11.8	2.23	12.5	2.43	13.3	2.62	15.0	2.97	16.6	3.27
48	8.4	1.46	10.1	1.84	11.8	2.30	12.5	2.51	13.3	2.72	15.0	3.07	16.6	3.35	
25%	10	4.6	0.46	5.0	0.46	5.8	0.46	6.2	0.51	6.6	0.57	7.4	0.66	8.2	0.75
	12	4.5	0.46	5.0	0.46	5.8	0.47	6.2	0.53	6.6	0.58	7.4	0.67	8.2	0.76
	14	4.4	0.46	5.0	0.46	5.8	0.48	6.2	0.54	6.6	0.60	7.4	0.69	8.2	0.77
	16	4.4	0.46	5.0	0.46	5.8	0.50	6.2	0.55	6.6	0.61	7.4	0.70	8.2	0.79
	18	4.3	0.46	5.0	0.46	5.8	0.51	6.2	0.57	6.6	0.62	7.4	0.71	8.2	0.80
	20	4.3	0.46	5.0	0.47	5.8	0.52	6.2	0.59	6.6	0.64	7.4	0.73	8.2	0.81
	21	4.2	0.46	5.0	0.47	5.8	0.53	6.2	0.59	6.6	0.65	7.4	0.74	8.2	0.82
	23	4.2	0.46	5.0	0.47	5.8	0.55	6.2	0.61	6.6	0.66	7.4	0.75	8.2	0.84
	25	4.2	0.46	5.0	0.47	5.8	0.56	6.2	0.62	6.6	0.69	7.4	0.79	8.2	0.88
	27	4.2	0.46	5.0	0.48	5.8	0.60	6.2	0.67	6.6	0.73	7.4	0.84	8.2	0.94
	29	4.2	0.47	5.0	0.50	5.8	0.64	6.2	0.71	6.6	0.78	7.4	0.89	8.2	1.00
	31	4.2	0.49	5.0	0.54	5.8	0.68	6.2	0.76	6.6	0.83	7.4	0.95	8.2	1.06
	33	4.2	0.51	5.0	0.58	5.8	0.73	6.2	0.81	6.6	0.88	7.4	1.00	8.2	1.11
	35	4.2	0.53	5.0	0.62	5.8	0.78	6.2	0.86	6.6	0.93	7.4	1.06	8.2	1.17
	37	4.2	0.55	5.0	0.66	5.8	0.83	6.2	0.92	6.6	0.99	7.4	1.12	8.2	1.23
	39	4.2	0.57	5.0	0.71	5.8	0.88	6.2	0.97	6.6	1.05	7.4	1.18	8.2	1.30
	43	4.2	0.63	5.0	0.78	5.8	0.97	6.2	1.07	6.6	1.15	7.4	1.29	8.2	1.44
	46	4.2	0.64	5.0	0.80	5.8	0.99	6.2	1.10	6.6	1.18	7.4	1.33	8.2	1.47
48	4.2	0.66	5.0	0.83	5.8	1.03	6.2	1.13	6.6	1.23	7.4	1.38	8.2	1.50	

Abbreviations:

TC: Total capacity (kW)

PI: Power input (compressor + outdoor fan motor) (kW)



Table 2-8.19: VMEX009Q8A-D16V280 cooling part load performance

Part load	Outdoor air temp. (°C DB)	Indoor air temp. (°C WB)													
		14.0		16.0		18.0		19.0		20.0		22.0		24.0	
		TC kW	PI kW	TC kW	PI kW	TC kW	PI kW	TC kW	PI kW	TC kW	PI kW	TC kW	PI kW	TC kW	PI kW
100%	10	18.9	2.15	22.5	2.60	26.2	3.08	28.0	3.33	29.8	3.58	33.5	4.09	35.4	4.23
	12	18.9	2.18	22.5	2.65	26.2	3.13	28.0	3.39	29.8	3.65	33.5	4.17	34.9	4.27
	14	18.9	2.22	22.5	2.70	26.2	3.19	28.0	3.45	29.8	3.71	33.5	4.25	34.5	4.32
	16	18.9	2.26	22.5	2.75	26.2	3.26	28.0	3.52	29.8	3.79	33.3	4.30	34.0	4.37
	18	18.9	2.31	22.5	2.80	26.2	3.32	28.0	3.59	29.8	3.86	32.9	4.44	33.6	4.48
	20	18.9	2.35	22.5	2.86	26.2	3.42	28.0	3.77	29.8	4.14	32.4	4.65	33.1	4.69
	21	18.9	2.37	22.5	2.88	26.2	3.55	28.0	3.91	29.8	4.28	32.2	4.76	32.9	4.80
	23	18.9	2.43	22.5	3.08	26.2	3.80	28.0	4.18	29.8	4.59	31.8	4.98	32.4	5.02
	25	18.9	2.59	22.5	3.29	26.2	4.07	28.0	4.48	29.8	4.92	31.3	5.20	32.0	5.24
	27	18.9	2.77	22.5	3.50	26.2	4.34	28.0	4.79	29.8	5.26	30.8	5.42	31.5	5.47
	29	18.9	2.94	22.5	3.74	26.2	4.64	28.0	5.12	29.7	5.59	30.4	5.64	31.1	5.68
	31	18.9	3.13	22.5	3.99	26.2	4.95	28.0	5.47	29.3	5.81	29.9	5.86	30.6	5.91
	33	18.9	3.33	22.5	4.25	26.2	5.27	28.0	5.83	28.8	6.03	29.5	6.08	30.2	6.14
	35	18.9	3.54	22.5	4.52	26.2	5.62	28.0	6.22	28.3	6.24	29.0	6.30	29.7	6.35
	37	18.9	3.76	22.5	4.81	26.2	5.99	27.5	6.44	27.9	6.47	28.6	6.53	29.2	6.58
	39	18.9	4.00	22.5	5.11	26.2	6.38	27.1	6.66	27.4	6.69	28.1	6.75	28.8	6.82
43	18.9	4.37	22.5	5.49	26.2	6.74	26.3	6.78	27.0	6.86	27.8	6.95	27.9	7.03	
46	18.9	4.63	22.5	5.75	26.2	6.85	25.7	6.87	26.9	6.98	27.5	7.06	27.3	7.13	
48	18.9	4.82	22.5	5.94	26.2	6.86	24.6	6.95	26.8	7.11	25.9	7.13	26.7	7.19	
75%	10	14.2	1.67	16.8	2.02	19.6	2.34	20.8	2.47	22.3	2.61	25.0	2.83	27.8	3.03
	12	14.2	1.70	16.8	2.06	19.6	2.37	20.8	2.51	22.3	2.64	25.0	2.87	27.8	3.06
	14	14.2	1.74	16.8	2.10	19.6	2.40	20.8	2.55	22.3	2.67	25.0	2.90	27.8	3.08
	16	14.2	1.77	16.8	2.13	19.6	2.44	20.8	2.58	22.3	2.71	25.0	2.93	27.8	3.11
	18	14.2	1.80	16.8	2.16	19.6	2.47	20.8	2.61	22.3	2.74	25.0	2.96	27.8	3.14
	20	14.2	1.84	16.8	2.20	19.6	2.51	20.8	2.65	22.3	2.77	25.0	2.99	27.8	3.25
	21	14.2	1.86	16.8	2.22	19.6	2.53	20.8	2.67	22.3	2.79	25.0	3.08	27.8	3.35
	23	14.2	1.89	16.8	2.26	19.6	2.60	20.8	2.78	22.3	2.95	25.0	3.26	27.8	3.55
	25	14.2	1.94	16.8	2.37	19.6	2.76	20.8	2.95	22.3	3.12	25.0	3.45	27.8	3.75
	27	14.2	2.06	16.8	2.51	19.6	2.93	20.8	3.12	22.3	3.31	25.0	3.65	27.8	3.96
	29	14.2	2.18	16.8	2.67	19.6	3.10	20.8	3.30	22.3	3.49	25.0	3.85	27.8	4.17
	31	14.2	2.32	16.8	2.82	19.6	3.28	20.8	3.48	22.3	3.69	25.0	4.06	27.8	4.39
	33	14.2	2.46	16.8	2.98	19.6	3.45	20.8	3.68	22.3	3.89	25.0	4.27	27.8	4.61
	35	14.2	2.60	16.8	3.15	19.6	3.64	20.8	3.87	22.3	4.09	25.0	4.49	27.8	4.84
	37	14.2	2.75	16.8	3.32	19.6	3.84	20.8	4.08	22.3	4.30	25.0	4.71	27.4	5.07
	39	14.2	2.91	16.8	3.50	19.6	4.04	20.8	4.29	22.3	4.52	25.0	4.95	27.0	5.31
43	14.2	3.20	16.8	3.85	19.6	4.44	20.8	4.72	22.3	4.97	25.0	5.43	26.7	5.70	
46	14.2	3.29	16.8	3.96	19.6	4.57	20.8	4.85	22.3	5.11	25.0	5.59	26.1	5.76	
48	14.2	3.40	16.8	4.10	19.6	4.73	20.8	5.02	22.3	5.29	25.0	5.78	25.6	5.86	
50%	10	10.1	1.23	11.2	1.22	13.1	1.25	13.9	1.40	14.8	1.54	16.7	1.81	18.5	2.04
	12	9.9	1.23	11.2	1.22	13.1	1.29	13.9	1.44	14.8	1.58	16.7	1.84	18.5	2.07
	14	9.7	1.23	11.2	1.22	13.1	1.32	13.9	1.47	14.8	1.61	16.7	1.88	18.5	2.10
	16	9.6	1.23	11.2	1.22	13.1	1.36	13.9	1.51	14.8	1.65	16.7	1.92	18.5	2.14
	18	9.5	1.23	11.2	1.22	13.1	1.40	13.9	1.55	14.8	1.69	16.7	1.95	18.5	2.18
	20	9.4	1.23	11.2	1.22	13.1	1.44	13.9	1.59	14.8	1.74	16.7	1.99	18.5	2.22
	21	9.4	1.23	11.2	1.22	13.1	1.45	13.9	1.61	14.8	1.75	16.7	2.02	18.5	2.23
	23	9.4	1.23	11.2	1.22	13.1	1.49	13.9	1.65	14.8	1.79	16.7	2.05	18.5	2.27
	25	9.4	1.23	11.2	1.22	13.1	1.53	13.9	1.69	14.8	1.86	16.7	2.15	18.5	2.42
	27	9.4	1.23	11.2	1.26	13.1	1.64	13.9	1.82	14.8	1.98	16.7	2.29	18.5	2.57
	29	9.4	1.28	11.2	1.36	13.1	1.75	13.9	1.94	14.8	2.11	16.7	2.43	18.5	2.71
	31	9.4	1.33	11.2	1.46	13.1	1.87	13.9	2.06	14.8	2.25	16.7	2.58	18.5	2.87
	33	9.4	1.37	11.2	1.57	13.1	2.00	13.9	2.20	14.8	2.39	16.7	2.73	18.5	3.04
	35	9.4	1.42	11.2	1.68	13.1	2.13	13.9	2.34	14.8	2.53	16.7	2.89	18.5	3.20
	37	9.4	1.48	11.2	1.80	13.1	2.26	13.9	2.48	14.8	2.68	16.7	3.05	18.5	3.37
	39	9.4	1.53	11.2	1.92	13.1	2.41	13.9	2.63	14.8	2.84	16.7	3.22	18.5	3.54
43	9.4	1.68	11.2	2.11	13.1	2.65	13.9	2.89	14.8	3.12	16.7	3.53	18.5	3.93	
46	9.4	1.73	11.2	2.17	13.1	2.72	13.9	2.98	14.8	3.21	16.7	3.64	18.5	4.00	
48	9.4	1.79	11.2	2.25	13.1	2.82	13.9	3.07	14.8	3.33	16.7	3.76	18.5	4.10	
25%	10	5.0	0.57	5.5	0.57	6.5	0.59	6.9	0.66	7.4	0.75	8.3	0.85	9.2	0.96
	12	5.0	0.57	5.5	0.57	6.5	0.60	6.9	0.67	7.4	0.76	8.3	0.86	9.2	0.97
	14	4.9	0.57	5.5	0.57	6.5	0.62	6.9	0.69	7.4	0.78	8.3	0.88	9.2	0.99
	16	4.8	0.57	5.5	0.58	6.5	0.64	6.9	0.71	7.4	0.80	8.3	0.90	9.2	1.00
	18	4.8	0.58	5.5	0.58	6.5	0.66	6.9	0.73	7.4	0.82	8.3	0.91	9.2	1.02
	20	4.7	0.58	5.5	0.58	6.5	0.67	6.9	0.74	7.4	0.83	8.3	0.93	9.2	1.04
	21	4.7	0.58	5.5	0.58	6.5	0.68	6.9	0.75	7.4	0.84	8.3	0.95	9.2	1.05
	23	4.7	0.58	5.5	0.58	6.5	0.70	6.9	0.77	7.4	0.88	8.3	0.96	9.2	1.06
	25	4.7	0.58	5.5	0.59	6.5	0.72	6.9	0.79	7.4	0.93	8.3	1.01	9.2	1.14
	27	4.7	0.58	5.5	0.59	6.5	0.77	6.9	0.85	7.4	1.00	8.3	1.07	9.2	1.21
	29	4.7	0.60	5.5	0.63	6.5	0.82	6.9	0.91	7.4	1.06	8.3	1.14	9.2	1.27
	31	4.7	0.63	5.5	0.68	6.5	0.88	6.9	0.96	7.4	1.13	8.3	1.21	9.2	1.35
	33	4.7	0.65	5.5	0.73	6.5	0.94	6.9	1.03	7.4	1.19	8.3	1.28	9.2	1.43
	35	4.7	0.67	5.5	0.78	6.5	1.00	6.9	1.10	7.4	1.26	8.3	1.36	9.2	1.50
	37	4.7	0.70	5.5	0.83	6.5	1.06	6.9	1.16	7.4	1.34	8.3	1.43	9.2	1.58
	39	4.7	0.72	5.5	0.89	6.5	1.13	6.9	1.23	7.4	1.40	8.3	1.51	9.2	1.66
43	4.7	0.79	5.5	0.98	6.5	1.24	6.9	1.35	7.4	1.54	8.3	1.66	9.2	1.85	
46	4.7	0.82	5.5	1.01	6.5	1.27	6.9	1.39	7.4	1.58	8.3	1.71	9.2	1.88	
48	4.7	0.84	5.5	1.04	6.5	1.32	6.9	1.44	7.4	1.64	8.3	1.76	9.2	1.93	

Abbreviations:

TC: Total capacity (kW)

PI: Power input (compressor + outdoor fan motor) (kW)

# VMEX 460V 60Hz

Table 2-8.20: VMEX010Q8A-D20V335 cooling part load

Part load	Outdoor air temp. (°C DB)	Indoor air temp. (°C WB)													
		14.0		16.0		18.0		19.0		20.0		22.0		24.0	
		TC kW	PI kW	TC kW	PI kW	TC kW	PI kW	TC kW	PI kW	TC kW	PI kW	TC kW	PI kW	TC kW	PI kW
100%	10	22.6	2.69	26.9	3.25	31.3	3.85	33.5	4.17	35.7	4.48	40.1	5.12	42.4	5.30
	12	22.6	2.73	26.9	3.32	31.3	3.93	33.5	4.24	35.7	4.57	40.1	5.22	41.8	5.34
	14	22.6	2.78	26.9	3.38	31.3	4.00	33.5	4.33	35.7	4.65	40.1	5.32	41.3	5.41
	16	22.6	2.83	26.9	3.44	31.3	4.08	33.5	4.41	35.7	4.75	39.8	5.39	40.7	5.47
	18	22.6	2.89	26.9	3.51	31.3	4.16	33.5	4.49	35.7	4.84	39.4	5.56	40.2	5.61
	20	22.6	2.94	26.9	3.58	31.3	4.28	33.5	4.72	35.7	5.19	38.8	5.83	39.6	5.88
	21	22.6	2.97	26.9	3.61	31.3	4.44	33.5	4.89	35.7	5.36	38.5	5.96	39.4	6.02
	23	22.6	3.04	26.9	3.85	31.3	4.76	33.5	5.24	35.7	5.75	38.0	6.24	38.8	6.29
	25	22.6	3.24	26.9	4.12	31.3	5.09	33.5	5.62	35.7	6.16	37.4	6.51	38.3	6.56
	27	22.6	3.46	26.9	4.39	31.3	5.44	33.5	6.01	35.7	6.59	36.9	6.78	37.7	6.85
	29	22.6	3.68	26.9	4.68	31.3	5.81	33.5	6.42	35.5	7.00	36.4	7.07	37.2	7.12
	31	22.6	3.93	26.9	5.00	31.3	6.19	33.5	6.85	35.1	7.28	35.8	7.34	36.6	7.40
	33	22.6	4.17	26.9	5.32	31.3	6.60	33.5	7.31	34.5	7.55	35.3	7.61	36.1	7.68
	35	22.6	4.43	26.9	5.66	31.3	7.04	33.5	7.79	33.9	7.82	34.7	7.89	35.5	7.96
	37	22.6	4.71	26.9	6.03	31.3	7.51	32.9	8.06	33.4	8.10	34.2	8.18	34.9	8.24
	39	22.6	5.01	26.9	6.40	31.3	7.99	32.4	8.34	32.8	8.38	33.6	8.45	34.5	8.54
	43	22.6	5.47	26.9	6.87	31.3	8.44	31.4	8.49	32.3	8.59	33.2	8.71	33.4	8.81
	46	22.6	5.83	26.9	7.21	31.3	8.58	30.7	8.64	32.1	8.77	33.0	8.86	32.7	8.96
48	22.6	6.04	26.9	7.43	31.3	8.59	29.5	8.71	32.1	8.90	30.9	8.93	32.0	9.01	
75%	10	16.9	2.07	20.1	2.51	23.4	2.90	24.9	3.07	26.7	3.24	29.9	3.52	33.2	3.76
	12	16.9	2.11	20.1	2.55	23.4	2.94	24.9	3.12	26.7	3.28	29.9	3.56	33.2	3.80
	14	16.9	2.15	20.1	2.60	23.4	2.98	24.9	3.16	26.7	3.32	29.9	3.60	33.2	3.83
	16	16.9	2.19	20.1	2.64	23.4	3.03	24.9	3.20	26.7	3.36	29.9	3.64	33.2	3.86
	18	16.9	2.23	20.1	2.68	23.4	3.07	24.9	3.24	26.7	3.40	29.9	3.68	33.2	3.90
	20	16.9	2.28	20.1	2.73	23.4	3.12	24.9	3.29	26.7	3.44	29.9	3.72	33.2	4.03
	21	16.9	2.30	20.1	2.75	23.4	3.14	24.9	3.31	26.7	3.47	29.9	3.82	33.2	4.15
	23	16.9	2.34	20.1	2.80	23.4	3.23	24.9	3.45	26.7	3.66	29.9	4.04	33.2	4.40
	25	16.9	2.40	20.1	2.94	23.4	3.43	24.9	3.66	26.7	3.88	29.9	4.28	33.2	4.65
	27	16.9	2.55	20.1	3.12	23.4	3.64	24.9	3.88	26.7	4.10	29.9	4.53	33.2	4.91
	29	16.9	2.71	20.1	3.31	23.4	3.85	24.9	4.09	26.7	4.33	29.9	4.78	33.2	5.17
	31	16.9	2.88	20.1	3.50	23.4	4.06	24.9	4.32	26.7	4.57	29.9	5.04	33.2	5.45
	33	16.9	3.05	20.1	3.70	23.4	4.28	24.9	4.56	26.7	4.82	29.9	5.30	33.2	5.72
	35	16.9	3.23	20.1	3.91	23.4	4.52	24.9	4.80	26.7	5.08	29.9	5.57	33.2	6.01
	37	16.9	3.42	20.1	4.12	23.4	4.76	24.9	5.06	26.7	5.34	29.9	5.85	32.8	6.29
	39	16.9	3.62	20.1	4.34	23.4	5.01	24.9	5.32	26.7	5.61	29.9	6.14	32.3	6.58
	43	16.9	3.98	20.1	4.77	23.4	5.51	24.9	5.85	26.7	6.16	29.9	6.73	31.7	7.01
	46	16.9	4.09	20.1	4.90	23.4	5.66	24.9	6.02	26.7	6.34	29.9	6.94	31.3	7.24
48	16.9	4.24	20.1	5.08	23.4	5.86	24.9	6.22	26.7	6.57	29.9	7.17	30.6	7.33	
50%	10	12.0	1.53	13.4	1.52	15.6	1.55	16.6	1.73	17.7	1.91	19.9	2.24	22.1	2.53
	12	11.8	1.53	13.4	1.52	15.6	1.60	16.6	1.78	17.7	1.96	19.9	2.28	22.1	2.57
	14	11.6	1.53	13.4	1.52	15.6	1.63	16.6	1.82	17.7	2.00	19.9	2.33	22.1	2.61
	16	11.5	1.53	13.4	1.52	15.6	1.68	16.6	1.87	17.7	2.05	19.9	2.38	22.1	2.66
	18	11.3	1.53	13.4	1.52	15.6	1.73	16.6	1.92	17.7	2.10	19.9	2.42	22.1	2.70
	20	11.2	1.53	13.4	1.52	15.6	1.78	16.6	1.97	17.7	2.15	19.9	2.47	22.1	2.75
	21	11.2	1.53	13.4	1.52	15.6	1.80	16.6	1.99	17.7	2.17	19.9	2.50	22.1	2.77
	23	11.2	1.53	13.4	1.52	15.6	1.85	16.6	2.04	17.7	2.22	19.9	2.54	22.1	2.82
	25	11.2	1.53	13.4	1.52	15.6	1.90	16.6	2.10	17.7	2.30	19.9	2.67	22.1	3.00
	27	11.2	1.53	13.4	1.57	15.6	2.03	16.6	2.25	17.7	2.46	19.9	2.84	22.1	3.19
	29	11.2	1.59	13.4	1.68	15.6	2.17	16.6	2.40	17.7	2.62	19.9	3.02	22.1	3.37
	31	11.2	1.64	13.4	1.81	15.6	2.32	16.6	2.56	17.7	2.79	19.9	3.20	22.1	3.57
	33	11.2	1.70	13.4	1.94	15.6	2.48	16.6	2.73	17.7	2.96	19.9	3.39	22.1	3.77
	35	11.2	1.76	13.4	2.08	15.6	2.64	16.6	2.90	17.7	3.14	19.9	3.59	22.1	3.96
	37	11.2	1.83	13.4	2.23	15.6	2.81	16.6	3.08	17.7	3.33	19.9	3.79	22.1	4.18
	39	11.2	1.89	13.4	2.38	15.6	2.99	16.6	3.27	17.7	3.53	19.9	3.99	22.1	4.39
	43	11.2	2.08	13.4	2.62	15.6	3.29	16.6	3.60	17.7	3.88	19.9	4.37	22.1	4.88
	46	11.2	2.14	13.4	2.69	15.6	3.38	16.6	3.70	17.7	3.99	19.9	4.51	22.1	4.97
48	11.2	2.21	13.4	2.78	15.6	3.50	16.6	3.82	17.7	4.13	19.9	4.66	22.1	5.09	
25%	10	6.0	0.74	6.7	0.75	7.8	0.76	8.3	0.88	8.8	0.93	9.9	1.09	11.0	1.24
	12	5.9	0.74	6.7	0.75	7.8	0.79	8.3	0.87	8.8	0.96	9.9	1.11	11.0	1.26
	14	5.9	0.75	6.7	0.75	7.8	0.80	8.3	0.89	8.8	0.98	9.9	1.14	11.0	1.27
	16	5.7	0.74	6.7	0.75	7.8	0.83	8.3	0.92	8.8	1.00	9.9	1.16	11.0	1.30
	18	5.7	0.74	6.7	0.75	7.8	0.85	8.3	0.94	8.8	1.03	9.9	1.18	11.0	1.32
	20	5.6	0.74	6.7	0.75	7.8	0.88	8.3	0.97	8.8	1.05	9.9	1.20	11.0	1.34
	21	5.6	0.74	6.7	0.75	7.8	0.89	8.3	0.98	8.8	1.06	9.9	1.22	11.0	1.35
	23	5.6	0.74	6.7	0.75	7.8	0.91	8.3	1.00	8.8	1.09	9.9	1.24	11.0	1.38
	25	5.6	0.74	6.7	0.75	7.8	0.94	8.3	1.03	8.8	1.13	9.9	1.30	11.0	1.47
	27	5.6	0.74	6.7	0.77	7.8	1.00	8.3	1.10	8.8	1.20	9.9	1.38	11.0	1.56
	29	5.6	0.77	6.7	0.82	7.8	1.07	8.3	1.18	8.8	1.28	9.9	1.47	11.0	1.65
	31	5.6	0.80	6.7	0.89	7.8	1.14	8.3	1.26	8.8	1.36	9.9	1.56	11.0	1.74
	33	5.6	0.83	6.7	0.95	7.8	1.22	8.3	1.34	8.8	1.45	9.9	1.65	11.0	1.84
	35	5.6	0.86	6.7	1.02	7.8	1.30	8.3	1.42	8.8	1.54	9.9	1.75	11.0	1.93
	37	5.6	0.89	6.7	1.09	7.8	1.39	8.3	1.51	8.8	1.63	9.9	1.85	11.0	2.04
	39	5.6	0.92	6.7	1.17	7.8	1.47	8.3	1.60	8.8	1.73	9.9	1.94	11.0	2.14
	43	5.6	1.01	6.7	1.28	7.8	1.62	8.3	1.76	8.8	1.90	9.9	2.13	11.0	2.38
	46	5.6	1.04	6.7	1.32	7.8	1.67	8.3	1.81	8.8	1.95	9.9	2.20	11.0	2.43
48	5.6	1.07	6.7	1.37	7.8	1.72	8.3	1.88	8.8	2.02	9.9	2.27	11.0	2.49	

Abbreviations:

TC: Total capacity (kW)

PI: Power input (compressor + outdoor fan motor) (kW)

Table 2-8.21: VMEX012Q8A-D23V400 cooling part load performance

Part load	Outdoor air temp. (°C DB)	Indoor air temp. (°C WB)													
		14.0		16.0		18.0		19.0		20.0		22.0		24.0	
		TC kW	PI kW	TC kW	PI kW	TC kW	PI kW	TC kW	PI kW	TC kW	PI kW	TC kW	PI kW	TC kW	PI kW
100%	10	27.0	3.21	32.1	3.89	37.4	4.60	40.0	4.98	42.6	5.35	47.9	6.12	50.6	6.33
	12	27.0	3.26	32.1	3.96	37.4	4.69	40.0	5.06	42.6	5.45	47.9	6.23	49.9	6.38
	14	27.0	3.32	32.1	4.04	37.4	4.78	40.0	5.16	42.6	5.55	47.9	6.35	49.3	6.46
	16	27.0	3.38	32.1	4.11	37.4	4.88	40.0	5.26	42.6	5.67	47.6	6.43	48.6	6.53
	18	27.0	3.45	32.1	4.19	37.4	4.96	40.0	5.36	42.6	5.78	47.0	6.64	48.0	6.69
	20	27.0	3.51	32.1	4.27	37.4	5.11	40.0	5.64	42.6	6.19	46.3	6.96	47.3	7.02
	21	27.0	3.55	32.1	4.31	37.4	5.30	40.0	5.84	42.6	6.40	46.0	7.12	47.0	7.18
	23	27.0	3.63	32.1	4.60	37.4	5.68	40.0	6.25	42.6	6.87	45.4	7.44	46.3	7.51
	25	27.0	3.87	32.1	4.91	37.4	6.08	40.0	6.71	42.6	7.36	44.7	7.77	45.7	7.83
	27	27.0	4.14	32.1	5.24	37.4	6.49	40.0	7.17	42.6	7.87	44.0	8.10	45.0	8.17
	29	27.0	4.40	32.1	5.59	37.4	6.93	40.0	7.66	42.4	8.36	43.4	8.44	44.4	8.50
	31	27.0	4.69	32.1	5.97	37.4	7.39	40.0	8.17	41.9	8.69	42.7	8.76	43.7	8.84
	33	27.0	4.98	32.1	6.35	37.4	7.88	40.0	8.72	41.1	9.01	42.1	9.09	43.1	9.17
	35	27.0	5.29	32.1	6.76	37.4	8.41	40.0	9.30	40.4	9.34	41.4	9.42	42.4	9.50
	37	27.0	5.63	32.1	7.19	37.4	8.96	39.3	9.63	39.9	9.68	40.9	9.76	41.7	9.84
	39	27.0	5.98	32.1	7.65	37.4	9.54	38.7	9.95	39.1	10.00	40.1	10.09	41.1	10.19
	43	27.0	6.54	32.1	8.20	37.4	10.07	37.5	10.14	38.6	10.25	39.7	10.39	39.8	10.52
	46	27.0	6.94	32.1	8.61	37.4	10.25	36.7	10.32	38.4	10.47	39.3	10.59	39.0	10.70
48	27.0	7.21	32.1	8.88	37.4	10.26	35.2	10.39	38.3	10.63	36.9	10.66	38.2	10.75	
75%	10	20.2	2.54	24.1	3.08	28.0	3.55	29.8	3.76	31.8	3.95	35.7	4.30	39.7	4.59
	12	20.2	2.59	24.1	3.13	28.0	3.60	29.8	3.81	31.8	4.00	35.7	4.35	39.7	4.64
	14	20.2	2.64	24.1	3.18	28.0	3.65	29.8	3.86	31.8	4.05	35.7	4.40	39.7	4.68
	16	20.2	2.69	24.1	3.23	28.0	3.70	29.8	3.91	31.8	4.11	35.7	4.44	39.7	4.72
	18	20.2	2.74	24.1	3.29	28.0	3.76	29.8	3.96	31.8	4.16	35.7	4.49	39.7	4.76
	20	20.2	2.79	24.1	3.34	28.0	3.81	29.8	4.02	31.8	4.21	35.7	4.54	39.7	4.94
	21	20.2	2.81	24.1	3.36	28.0	3.84	29.8	4.05	31.8	4.23	35.7	4.67	39.7	5.08
	23	20.2	2.86	24.1	3.42	28.0	3.94	29.8	4.21	31.8	4.48	35.7	4.95	39.7	5.39
	25	20.2	2.94	24.1	3.59	28.0	4.19	29.8	4.48	31.8	4.74	35.7	5.24	39.7	5.69
	27	20.2	3.13	24.1	3.81	28.0	4.44	29.8	4.74	31.8	5.02	35.7	5.54	39.7	6.00
	29	20.2	3.32	24.1	4.04	28.0	4.70	29.8	5.01	31.8	5.30	35.7	5.84	39.7	6.33
	31	20.2	3.52	24.1	4.27	28.0	4.97	29.8	5.29	31.8	5.60	35.7	6.16	39.7	6.66
	33	20.2	3.73	24.1	4.53	28.0	5.24	29.8	5.58	31.8	5.89	35.7	6.48	39.7	7.00
	35	20.2	3.95	24.1	4.78	28.0	5.53	29.8	5.88	31.8	6.21	35.7	6.81	39.7	7.34
	37	20.2	4.18	24.1	5.04	28.0	5.83	29.8	6.19	31.8	6.53	35.7	7.15	39.2	7.69
	39	20.2	4.42	24.1	5.32	28.0	6.13	29.8	6.50	31.8	6.86	35.7	7.50	38.6	8.06
	43	20.2	4.86	24.1	5.85	28.0	6.74	29.8	7.15	31.8	7.54	35.7	8.22	38.1	8.86
	46	20.2	4.99	24.1	6.01	28.0	6.93	29.8	7.35	31.8	7.75	35.7	8.47	37.5	9.02
48	20.2	5.17	24.1	6.22	28.0	7.17	29.8	7.60	31.8	8.03	35.7	8.76	36.8	9.14	
50%	10	13.4	1.81	16.0	1.80	18.6	1.78	19.8	1.95	21.3	2.17	23.8	2.57	26.4	2.92
	12	13.4	1.81	16.0	1.80	18.6	1.78	19.8	2.00	21.3	2.22	23.8	2.63	26.4	2.97
	14	13.4	1.81	16.0	1.81	18.6	1.83	19.8	2.06	21.3	2.28	23.8	2.69	26.4	3.03
	16	13.4	1.81	16.0	1.80	18.6	1.89	19.8	2.12	21.3	2.34	23.8	2.74	26.4	3.08
	18	13.4	1.81	16.0	1.86	18.6	1.94	19.8	2.18	21.3	2.40	23.8	2.80	26.4	3.14
	20	13.4	1.81	16.0	1.86	18.6	2.00	19.8	2.24	21.3	2.46	23.8	2.86	26.4	3.19
	21	13.4	1.81	16.0	1.86	18.6	2.04	19.8	2.27	21.3	2.49	23.8	2.89	26.4	3.23
	23	13.4	1.81	16.0	1.86	18.6	2.10	19.8	2.33	21.3	2.55	23.8	2.95	26.4	3.29
	25	13.4	1.81	16.0	1.86	18.6	2.16	19.8	2.40	21.3	2.65	23.8	3.10	26.4	3.50
	27	13.4	1.81	16.0	1.82	18.6	2.31	19.8	2.58	21.3	2.83	23.8	3.30	26.4	3.72
	29	13.4	1.88	16.0	1.89	18.6	2.48	19.8	2.75	21.3	3.02	23.8	3.51	26.4	3.94
	31	13.4	1.95	16.0	2.02	18.6	2.65	19.8	2.94	21.3	3.22	23.8	3.73	26.4	4.17
	33	13.4	2.03	16.0	2.18	18.6	2.83	19.8	3.13	21.3	3.42	23.8	3.94	26.4	4.41
	35	13.4	2.10	16.0	2.34	18.6	3.02	19.8	3.34	21.3	3.64	23.8	4.18	26.4	4.65
	37	13.4	2.17	16.0	2.52	18.6	3.23	19.8	3.55	21.3	3.86	23.8	4.42	26.4	4.90
	39	13.4	2.25	16.0	2.70	18.6	3.44	19.8	3.78	21.3	4.09	23.8	4.66	26.4	5.16
	43	13.4	2.48	16.0	2.97	18.6	3.78	19.8	4.16	21.3	4.49	23.8	5.11	26.4	5.73
	46	13.4	2.54	16.0	3.05	18.6	3.89	19.8	4.28	21.3	4.62	23.8	5.26	26.4	5.84
48	13.4	2.63	16.0	3.16	18.6	4.02	19.8	4.42	21.3	4.79	23.8	5.44	26.4	5.98	
25%	10	6.7	0.88	7.9	0.87	9.3	0.87	9.9	0.94	10.6	1.06	11.8	1.25	13.1	1.42
	12	6.7	0.88	7.9	0.87	9.3	0.87	9.9	0.97	10.6	1.08	11.8	1.28	13.1	1.45
	14	6.7	0.88	7.9	0.87	9.3	0.89	9.9	1.00	10.6	1.11	11.8	1.31	13.1	1.47
	16	6.7	0.88	7.9	0.88	9.3	0.92	9.9	1.03	10.6	1.14	11.8	1.33	13.1	1.50
	18	6.7	0.88	7.9	0.89	9.3	0.94	9.9	1.06	10.6	1.17	11.8	1.36	13.1	1.53
	20	6.7	0.88	7.9	0.89	9.3	0.97	9.9	1.09	10.6	1.20	11.8	1.39	13.1	1.55
	21	6.7	0.88	7.9	0.89	9.3	0.99	9.9	1.10	10.6	1.22	11.8	1.40	13.1	1.57
	23	6.7	0.88	7.9	0.89	9.3	1.02	9.9	1.13	10.6	1.25	11.8	1.43	13.1	1.60
	25	6.7	0.88	7.9	0.89	9.3	1.05	9.9	1.16	10.6	1.29	11.8	1.51	13.1	1.70
	27	6.7	0.88	7.9	0.89	9.3	1.12	9.9	1.25	10.6	1.38	11.8	1.60	13.1	1.81
	29	6.7	0.92	7.9	0.91	9.3	1.21	9.9	1.33	10.6	1.48	11.8	1.71	13.1	1.92
	31	6.7	0.95	7.9	0.97	9.3	1.29	9.9	1.42	10.6	1.57	11.8	1.81	13.1	2.03
	33	6.7	0.99	7.9	1.05	9.3	1.38	9.9	1.52	10.6	1.67	11.8	1.91	13.1	2.15
	35	6.7	1.02	7.9	1.12	9.3	1.47	9.9	1.62	10.6	1.78	11.8	2.03	13.1	2.26
	37	6.7	1.06	7.9	1.21	9.3	1.57	9.9	1.72	10.6	1.89	11.8	2.15	13.1	2.38
	39	6.7	1.10	7.9	1.30	9.3	1.67	9.9	1.83	10.6	2.00	11.8	2.26	13.1	2.51
	43	6.7	1.21	7.9	1.43	9.3	1.84	9.9	2.01	10.6	2.20	11.8	2.48	13.1	2.79
	46	6.7	1.24	7.9	1.46	9.3	1.89	9.9	2.07	10.6	2.26	11.8	2.56	13.1	2.84
48	6.7	1.28	7.9	1.52	9.3	1.96	9.9	2.14	10.6	2.34	11.8	2.65	13.1	2.91	

Abbreviations:

TC: Total capacity (kW)

PI: Power input (compressor + outdoor fan motor) (kW)

# VMEX 460V 60Hz

Table 2-8.22: VMEX014Q8A-D26V450 cooling part load

Part load	Outdoor air temp. (°C DB)	Indoor air temp. (°C WB)													
		14.0		16.0		18.0		19.0		20.0		22.0		24.0	
		TC kW	PI kW	TC kW	PI kW	TC kW	PI kW	TC kW	PI kW	TC kW	PI kW	TC kW	PI kW	TC kW	PI kW
100%	10	30.4	3.79	36.2	4.59	42.1	5.43	45.0	5.87	47.9	6.32	53.8	7.22	56.9	7.47
	12	30.4	3.85	36.2	4.68	42.1	5.53	45.0	5.98	47.9	6.44	53.8	7.35	56.1	7.53
	14	30.4	3.92	36.2	4.77	42.1	5.64	45.0	6.10	47.9	6.56	53.8	7.50	55.4	7.62
	16	30.4	4.00	36.2	4.85	42.1	5.76	45.0	6.21	47.9	6.69	53.5	7.59	54.6	7.71
	18	30.4	4.07	36.2	4.94	42.1	5.86	45.0	6.33	47.9	6.82	52.9	7.84	54.0	7.90
	20	30.4	4.14	36.2	5.05	42.1	6.04	45.0	6.66	47.9	7.31	52.1	8.21	53.2	8.29
	21	30.4	4.19	36.2	5.09	42.1	6.26	45.0	6.90	47.9	7.56	51.8	8.41	52.9	8.48
	23	30.4	4.29	36.2	5.43	42.1	6.70	45.0	7.38	47.9	8.11	51.1	8.79	52.1	8.86
	25	30.4	4.57	36.2	5.80	42.1	7.18	45.0	7.92	47.9	8.69	50.3	9.17	51.4	9.25
	27	30.4	4.88	36.2	6.19	42.1	7.67	45.0	8.46	47.9	9.29	49.5	9.56	50.6	9.65
	29	30.4	5.19	36.2	6.60	42.1	8.18	45.0	9.04	47.7	9.87	48.9	9.96	50.0	10.03
	31	30.4	5.53	36.2	7.04	42.1	8.73	45.0	9.65	47.1	10.26	48.1	10.34	49.2	10.43
	33	30.4	5.87	36.2	7.50	42.1	9.31	45.0	10.30	46.3	10.64	47.4	10.73	48.5	10.83
	35	30.4	6.24	36.2	7.98	42.1	9.93	45.0	10.98	45.5	11.02	46.6	11.13	47.7	11.22
	37	30.4	6.64	36.2	8.49	42.1	10.58	44.2	11.36	44.8	11.42	46.0	11.53	46.9	11.62
	39	30.4	7.06	36.2	9.03	42.1	11.26	43.6	11.75	44.0	11.81	45.2	11.91	46.3	12.03
43	30.4	7.72	36.2	9.69	42.1	11.89	42.2	11.97	43.4	12.11	44.6	12.27	44.8	12.42	
46	30.4	8.19	36.2	10.17	42.1	12.10	41.3	12.16	43.2	12.37	44.3	12.50	43.9	12.62	
48	30.4	8.51	36.2	10.48	42.1	12.11	39.6	12.27	43.1	12.54	41.6	12.59	42.9	12.70	
75%	10	22.7	2.94	27.1	3.57	31.5	4.12	33.6	4.36	35.8	4.59	40.2	4.99	44.6	5.33
	12	22.7	3.00	27.1	3.63	31.5	4.17	33.6	4.42	35.8	4.64	40.2	5.05	44.6	5.38
	14	22.7	3.06	27.1	3.68	31.5	4.23	33.6	4.48	35.8	4.70	40.2	5.10	44.6	5.43
	16	22.7	3.12	27.1	3.74	31.5	4.29	33.6	4.54	35.8	4.76	40.2	5.15	44.6	5.48
	18	22.7	3.18	27.1	3.81	31.5	4.36	33.6	4.60	35.8	4.82	40.2	5.21	44.6	5.53
	20	22.7	3.23	27.1	3.87	31.5	4.42	33.6	4.66	35.8	4.88	40.2	5.26	44.6	5.73
	21	22.7	3.26	27.1	3.90	31.5	4.45	33.6	4.69	35.8	4.91	40.2	5.42	44.6	5.90
	23	22.7	3.32	27.1	3.97	31.5	4.58	33.6	4.89	35.8	5.19	40.2	5.74	44.6	6.25
	25	22.7	3.41	27.1	4.16	31.5	4.86	33.6	5.19	35.8	5.50	40.2	6.08	44.6	6.60
	27	22.7	3.63	27.1	4.42	31.5	5.15	33.6	5.50	35.8	5.82	40.2	6.43	44.6	6.96
	29	22.7	3.85	27.1	4.68	31.5	5.46	33.6	5.81	35.8	6.15	40.2	6.78	44.6	7.34
	31	22.7	4.09	27.1	4.96	31.5	5.76	33.6	6.13	35.8	6.49	40.2	7.14	44.6	7.73
	33	22.7	4.33	27.1	5.25	31.5	6.08	33.6	6.48	35.8	6.84	40.2	7.51	44.6	8.12
	35	22.7	4.59	27.1	5.55	31.5	6.42	33.6	6.82	35.8	7.20	40.2	7.90	44.6	8.51
	37	22.7	4.85	27.1	5.85	31.5	6.76	33.6	7.18	35.8	7.57	40.2	8.30	44.1	8.92
	39	22.7	5.12	27.1	6.17	31.5	7.11	33.6	7.54	35.8	7.95	40.2	8.70	43.4	9.34
43	22.7	5.63	27.1	6.79	31.5	7.82	33.6	8.29	35.8	8.73	40.2	9.54	43.1	10.38	
46	22.7	5.79	27.1	6.97	31.5	8.03	33.6	8.53	35.8	8.98	40.2	9.83	42.9	10.57	
48	22.7	5.99	27.1	7.22	31.5	8.32	33.6	8.82	35.8	9.31	40.2	10.17	42.5	10.83	
50%	10	15.1	2.10	18.0	2.09	20.9	2.07	22.3	2.27	23.9	2.52	26.8	2.98	29.7	3.39
	12	15.1	2.10	18.0	2.09	20.9	2.07	22.3	2.32	23.9	2.58	26.8	3.05	29.7	3.45
	14	15.1	2.10	18.0	2.10	20.9	2.12	22.3	2.39	23.9	2.65	26.8	3.12	29.7	3.52
	16	15.1	2.10	18.0	2.09	20.9	2.19	22.3	2.46	23.9	2.72	26.8	3.18	29.7	3.58
	18	15.1	2.10	18.0	2.16	20.9	2.26	22.3	2.53	23.9	2.78	26.8	3.24	29.7	3.65
	20	15.1	2.10	18.0	2.16	20.9	2.32	22.3	2.60	23.9	2.85	26.8	3.31	29.7	3.70
	21	15.1	2.10	18.0	2.16	20.9	2.36	22.3	2.64	23.9	2.89	26.8	3.35	29.7	3.74
	23	15.1	2.10	18.0	2.16	20.9	2.43	22.3	2.71	23.9	2.96	26.8	3.42	29.7	3.81
	25	15.1	2.10	18.0	2.16	20.9	2.51	22.3	2.78	23.9	3.07	26.8	3.60	29.7	4.06
	27	15.1	2.10	18.0	2.11	20.9	2.68	22.3	2.99	23.9	3.28	26.8	3.82	29.7	4.31
	29	15.1	2.18	18.0	2.19	20.9	2.87	22.3	3.20	23.9	3.50	26.8	4.07	29.7	4.57
	31	15.1	2.27	18.0	2.34	20.9	3.08	22.3	3.41	23.9	3.73	26.8	4.32	29.7	4.84
	33	15.1	2.35	18.0	2.53	20.9	3.28	22.3	3.64	23.9	3.97	26.8	4.58	29.7	5.11
	35	15.1	2.44	18.0	2.72	20.9	3.51	22.3	3.87	23.9	4.22	26.8	4.85	29.7	5.39
	37	15.1	2.52	18.0	2.92	20.9	3.74	22.3	4.12	23.9	4.48	26.8	5.12	29.7	5.68
	39	15.1	2.61	18.0	3.13	20.9	3.99	22.3	4.38	23.9	4.74	26.8	5.41	29.7	5.99
43	15.1	2.87	18.0	3.44	20.9	4.39	22.3	4.82	23.9	5.21	26.8	5.93	29.7	6.66	
46	15.1	2.95	18.0	3.54	20.9	4.51	22.3	4.95	23.9	5.35	26.8	6.11	29.7	6.78	
48	15.1	3.05	18.0	3.66	20.9	4.67	22.3	5.12	23.9	5.55	26.8	6.32	29.7	6.94	
25%	10	7.5	1.03	8.9	1.03	10.4	1.01	11.1	1.10	11.9	1.23	13.3	1.45	14.8	1.65
	12	7.5	1.03	8.9	1.03	10.4	1.01	11.1	1.12	11.9	1.26	13.3	1.49	14.8	1.68
	14	7.5	1.03	8.9	1.03	10.4	1.04	11.1	1.16	11.9	1.29	13.3	1.52	14.8	1.71
	16	7.5	1.03	8.9	1.03	10.4	1.07	11.1	1.19	11.9	1.32	13.3	1.55	14.8	1.74
	18	7.5	1.03	8.9	1.06	10.4	1.10	11.1	1.22	11.9	1.35	13.3	1.58	14.8	1.78
	20	7.5	1.03	8.9	1.06	10.4	1.13	11.1	1.26	11.9	1.39	13.3	1.61	14.8	1.80
	21	7.5	1.03	8.9	1.06	10.4	1.15	11.1	1.28	11.9	1.41	13.3	1.63	14.8	1.82
	23	7.5	1.03	8.9	1.06	10.4	1.19	11.1	1.31	11.9	1.44	13.3	1.67	14.8	1.85
	25	7.5	1.03	8.9	1.06	10.4	1.23	11.1	1.35	11.9	1.49	13.3	1.75	14.8	1.97
	27	7.5	1.03	8.9	1.06	10.4	1.31	11.1	1.45	11.9	1.60	13.3	1.86	14.8	2.10
	29	7.5	1.07	8.9	1.08	10.4	1.40	11.1	1.55	11.9	1.70	13.3	1.98	14.8	2.22
	31	7.5	1.12	8.9	1.15	10.4	1.50	11.1	1.65	11.9	1.82	13.3	2.10	14.8	2.35
	33	7.5	1.16	8.9	1.24	10.4	1.60	11.1	1.76	11.9	1.93	13.3	2.23	14.8	2.49
	35	7.5	1.20	8.9	1.34	10.4	1.71	11.1	1.87	11.9	2.05	13.3	2.36	14.8	2.62
	37	7.5	1.24	8.9	1.44	10.4	1.83	11.1	1.99	11.9	2.18	13.3	2.49	14.8	2.76
	39	7.5	1.28	8.9	1.54	10.4	1.95	11.1	2.12	11.9	2.31	13.3	2.64	14.8	2.91
43	7.5	1.41	8.9	1.69	10.4	2.14	11.1	2.33	11.9	2.54	13.3	2.89	14.8	3.24	
46	7.5	1.45	8.9	1.74	10.4	2.20	11.1	2.40	11.9	2.61	13.3	2.98	14.8	3.30	
48	7.5	1.50	8.9	1.80	10.4	2.28	11.1	2.48	11.9	2.70	13.3	3.08	14.8	3.38	

Abbreviations:

TC: Total capacity (kW)

PI: Power input (compressor + outdoor fan motor) (kW)

Table 2-8.23: VMEX016Q8A-D29V500 cooling part load performance

Part load	Outdoor air temp. (°C DB)	Indoor air temp. (°C WB)													
		14.0		16.0		18.0		19.0		20.0		22.0		24.0	
		TC kW	PI kW	TC kW	PI kW	TC kW	PI kW	TC kW	PI kW	TC kW	PI kW	TC kW	PI kW	TC kW	PI kW
100%	10	33.8	4.42	40.2	5.36	46.8	6.34	50.0	6.86	53.2	7.38	59.8	8.43	63.2	8.73
	12	33.8	4.49	40.2	5.46	46.8	6.46	50.0	6.98	53.2	7.52	59.8	8.59	62.3	8.79
	14	33.8	4.58	40.2	5.56	46.8	6.58	50.0	7.12	53.2	7.65	59.8	8.76	61.6	8.90
	16	33.8	4.67	40.2	5.67	46.8	6.72	50.0	7.26	53.2	7.81	59.5	8.86	60.7	9.00
	18	33.8	4.75	40.2	5.77	46.8	6.84	50.0	7.39	53.2	7.97	58.8	9.16	60.0	9.23
	20	33.8	4.84	40.2	5.89	46.8	7.05	50.0	7.77	53.2	8.54	57.9	9.59	59.1	9.68
	21	33.8	4.89	40.2	5.94	46.8	7.31	50.0	8.05	53.2	8.83	57.5	9.81	58.8	9.90
	23	33.8	5.01	40.2	6.34	46.8	7.83	50.0	8.62	53.2	9.47	56.8	10.26	57.9	10.35
	25	33.8	5.34	40.2	6.77	46.8	8.38	50.0	9.24	53.2	10.14	55.9	10.71	57.1	10.80
	27	33.8	5.70	40.2	7.22	46.8	8.95	50.0	9.88	53.2	10.85	55.0	11.16	56.3	11.26
	29	33.8	6.06	40.2	7.71	46.8	9.55	50.0	10.56	53.0	11.52	54.3	11.63	55.5	11.71
	31	33.8	6.46	40.2	8.22	46.8	10.19	50.0	11.26	52.3	11.97	53.4	12.08	54.6	12.18
	33	33.8	6.86	40.2	8.76	46.8	10.87	50.0	12.03	51.4	12.42	52.7	12.53	53.9	12.65
	35	33.8	7.29	40.2	9.31	46.8	11.59	50.0	12.82	50.5	12.87	51.8	12.99	53.0	13.10
	37	33.8	7.76	40.2	9.92	46.8	12.35	49.1	13.27	49.8	13.34	51.1	13.46	52.1	13.56
	39	33.8	8.24	40.2	10.54	46.8	13.15	48.4	13.72	48.9	13.79	50.2	13.91	51.4	14.05
	43	33.8	9.01	40.2	11.31	46.8	13.88	46.9	13.98	48.2	14.13	49.6	14.33	49.8	14.50
	46	33.8	9.62	40.2	11.92	46.8	14.12	45.9	14.20	48.0	14.43	49.2	14.59	48.8	14.72
48	33.8	9.94	40.2	12.24	46.8	14.14	44.0	14.33	47.9	14.65	46.2	14.70	47.7	14.83	
75%	10	25.2	3.41	30.1	4.14	35.0	4.77	37.3	5.06	39.8	5.32	44.7	5.78	49.6	6.18
	12	25.2	3.48	30.1	4.21	35.0	4.84	37.3	5.12	39.8	5.39	44.7	5.85	49.6	6.24
	14	25.2	3.55	30.1	4.27	35.0	4.91	37.3	5.19	39.8	5.45	44.7	5.92	49.6	6.29
	16	25.2	3.61	30.1	4.34	35.0	4.98	37.3	5.26	39.8	5.52	44.7	5.98	49.6	6.35
	18	25.2	3.68	30.1	4.42	35.0	5.06	37.3	5.33	39.8	5.59	44.7	6.04	49.6	6.41
	20	25.2	3.75	30.1	4.49	35.0	5.12	37.3	5.41	39.8	5.66	44.7	6.10	49.6	6.65
	21	25.2	3.79	30.1	4.52	35.0	5.16	37.3	5.44	39.8	5.69	44.7	6.28	49.6	6.84
	23	25.2	3.85	30.1	4.60	35.0	5.31	37.3	5.67	39.8	6.02	44.7	6.66	49.6	7.25
	25	25.2	3.96	30.1	4.83	35.0	5.64	37.3	6.02	39.8	6.37	44.7	7.05	49.6	7.66
	27	25.2	4.21	30.1	5.12	35.0	5.98	37.3	6.37	39.8	6.75	44.7	7.45	49.6	8.08
	29	25.2	4.47	30.1	5.43	35.0	6.33	37.3	6.74	39.8	7.13	44.7	7.86	49.6	8.51
	31	25.2	4.74	30.1	5.75	35.0	6.68	37.3	7.11	39.8	7.53	44.7	8.28	49.6	8.96
	33	25.2	5.02	30.1	6.09	35.0	7.05	37.3	7.51	39.8	7.93	44.7	8.71	49.6	9.42
	35	25.2	5.32	30.1	6.43	35.0	7.44	37.3	7.91	39.8	8.35	44.7	9.17	49.6	9.87
	37	25.2	5.62	30.1	6.78	35.0	7.84	37.3	8.33	39.8	8.78	44.7	9.62	49.0	10.35
	39	25.2	5.94	30.1	7.16	35.0	8.25	37.3	8.75	39.8	9.22	44.7	10.09	48.2	10.84
	43	25.2	6.53	30.1	7.88	35.0	9.08	37.3	9.63	39.8	10.13	44.7	11.06	48.2	12.04
	46	25.2	6.71	30.1	8.09	35.0	9.32	37.3	9.90	39.8	10.41	44.7	11.40	48.2	12.26
48	25.2	6.95	30.1	8.38	35.0	9.65	37.3	10.23	39.8	10.80	44.7	11.79	48.2	12.57	
50%	10	16.8	2.43	20.0	2.42	23.2	2.40	24.8	2.63	26.6	2.92	29.8	3.46	33.0	3.93
	12	16.8	2.43	20.0	2.42	23.2	2.40	24.8	2.70	26.6	2.99	29.8	3.54	33.0	4.00
	14	16.8	2.43	20.0	2.43	23.2	2.46	24.8	2.77	26.6	3.07	29.8	3.61	33.0	4.08
	16	16.8	2.43	20.0	2.42	23.2	2.54	24.8	2.85	26.6	3.15	29.8	3.68	33.0	4.15
	18	16.8	2.43	20.0	2.50	23.2	2.62	24.8	2.93	26.6	3.23	29.8	3.76	33.0	4.23
	20	16.8	2.43	20.0	2.50	23.2	2.70	24.8	3.01	26.6	3.31	29.8	3.84	33.0	4.30
	21	16.8	2.43	20.0	2.50	23.2	2.74	24.8	3.06	26.6	3.35	29.8	3.89	33.0	4.34
	23	16.8	2.43	20.0	2.50	23.2	2.82	24.8	3.14	26.6	3.43	29.8	3.97	33.0	4.42
	25	16.8	2.43	20.0	2.50	23.2	2.91	24.8	3.23	26.6	3.56	29.8	4.17	33.0	4.70
	27	16.8	2.43	20.0	2.45	23.2	3.10	24.8	3.47	26.6	3.81	29.8	4.43	33.0	5.00
	29	16.8	2.52	20.0	2.54	23.2	3.33	24.8	3.71	26.6	4.06	29.8	4.72	33.0	5.30
	31	16.8	2.63	20.0	2.72	23.2	3.57	24.8	3.96	26.6	4.33	29.8	5.01	33.0	5.61
	33	16.8	2.73	20.0	2.93	23.2	3.81	24.8	4.22	26.6	4.60	29.8	5.31	33.0	5.93
	35	16.8	2.83	20.0	3.15	23.2	4.07	24.8	4.49	26.6	4.90	29.8	5.62	33.0	6.25
	37	16.8	2.92	20.0	3.39	23.2	4.34	24.8	4.77	26.6	5.19	29.8	5.94	33.0	6.59
	39	16.8	3.02	20.0	3.63	23.2	4.63	24.8	5.08	26.6	5.50	29.8	6.27	33.0	6.94
	43	16.8	3.32	20.0	3.99	23.2	5.09	24.8	5.59	26.6	6.04	29.8	6.87	33.0	7.71
	46	16.8	3.41	20.0	4.10	23.2	5.23	24.8	5.75	26.6	6.21	29.8	7.08	33.0	7.85
48	16.8	3.53	20.0	4.25	23.2	5.42	24.8	5.94	26.6	6.44	29.8	7.33	33.0	8.05	
25%	10	8.4	1.17	9.9	1.17	11.5	1.16	12.4	1.29	13.2	1.43	14.8	1.69	16.4	1.92
	12	8.4	1.17	9.9	1.17	11.5	1.16	12.4	1.32	13.2	1.46	14.8	1.73	16.4	1.95
	14	8.4	1.17	9.9	1.17	11.5	1.19	12.4	1.36	13.2	1.50	14.8	1.76	16.4	1.99
	16	8.4	1.17	9.9	1.17	11.5	1.23	12.4	1.39	13.2	1.54	14.8	1.80	16.4	2.03
	18	8.4	1.17	9.9	1.20	11.5	1.26	12.4	1.43	13.2	1.58	14.8	1.83	16.4	2.06
	20	8.4	1.17	9.9	1.20	11.5	1.30	12.4	1.47	13.2	1.62	14.8	1.87	16.4	2.10
	21	8.4	1.17	9.9	1.20	11.5	1.32	12.4	1.50	13.2	1.64	14.8	1.90	16.4	2.12
	23	8.4	1.17	9.9	1.20	11.5	1.36	12.4	1.54	13.2	1.68	14.8	1.94	16.4	2.16
	25	8.4	1.17	9.9	1.20	11.5	1.40	12.4	1.58	13.2	1.74	14.8	2.03	16.4	2.29
	27	8.4	1.17	9.9	1.20	11.5	1.50	12.4	1.70	13.2	1.87	14.8	2.16	16.4	2.44
	29	8.4	1.22	9.9	1.22	11.5	1.61	12.4	1.82	13.2	1.99	14.8	2.30	16.4	2.59
	31	8.4	1.27	9.9	1.31	11.5	1.72	12.4	1.94	13.2	2.12	14.8	2.44	16.4	2.74
	33	8.4	1.32	9.9	1.41	11.5	1.84	12.4	2.06	13.2	2.25	14.8	2.59	16.4	2.89
	35	8.4	1.36	9.9	1.52	11.5	1.96	12.4	2.20	13.2	2.40	14.8	2.74	16.4	3.05
	37	8.4	1.41	9.9	1.63	11.5	2.09	12.4	2.33	13.2	2.54	14.8	2.90	16.4	3.22
	39	8.4	1.46	9.9	1.75	11.5	2.23	12.4	2.49	13.2	2.69	14.8	3.06	16.4	3.39
	43	8.4	1.60	9.9	1.92	11.5	2.46	12.4	2.73	13.2	2.96	14.8	3.35	16.4	3.76
	46	8.4	1.98	9.9	1.98	11.5	2.52	12.4	2.81	13.2	3.04	14.8	3.46	16.4	3.83
48	8.4	2.05	9.9	2.05	11.5	2.61	12.4	2.91	13.2	3.15	14.8	3.57	16.4	3.93	

Abbreviations:

TC: Total capacity (kW)

PI: Power input (compressor + outdoor fan motor) (kW)

# VMEX 460V 60Hz

Table 2-8.24: VMEX018Q8A-D33V560 cooling part load

Part load	Outdoor air temp. (°C DB)	Indoor air temp. (°C WB)													
		14.0		16.0		18.0		19.0		20.0		22.0		24.0	
		TC kW	PI kW	TC kW	PI kW	TC kW	PI kW	TC kW	PI kW	TC kW	PI kW	TC kW	PI kW	TC kW	PI kW
100%	10	37.8	5.01	45.0	6.06	52.4	7.18	56.0	7.76	59.6	8.35	67.0	9.54	70.8	9.88
	12	37.8	5.08	45.0	6.18	52.4	7.31	56.0	7.90	59.6	8.51	67.0	9.72	69.8	9.95
	14	37.8	5.18	45.0	6.30	52.4	7.45	56.0	8.06	59.6	8.66	67.0	9.91	69.0	10.07
	16	37.8	5.28	45.0	6.41	52.4	7.61	56.0	8.21	59.6	8.84	66.6	10.03	68.0	10.19
	18	37.8	5.38	45.0	6.53	52.4	7.74	56.0	8.37	59.6	9.02	65.8	10.36	67.2	10.44
	20	37.8	5.48	45.0	6.67	52.4	7.98	56.0	8.80	59.6	9.66	64.8	10.85	66.2	10.95
	21	37.8	5.53	45.0	6.73	52.4	8.27	56.0	9.11	59.6	9.99	64.4	11.11	65.8	11.20
	23	37.8	5.67	45.0	7.18	52.4	8.86	56.0	9.76	59.6	10.72	63.6	11.62	64.8	11.71
	25	37.8	6.04	45.0	7.67	52.4	9.48	56.0	10.46	59.6	11.48	62.6	12.12	64.0	12.22
	27	37.8	6.45	45.0	8.17	52.4	10.13	56.0	11.19	59.6	12.28	61.6	12.63	63.0	12.75
	29	37.8	6.86	45.0	8.72	52.4	10.81	56.0	11.95	59.4	13.04	60.8	13.16	62.2	13.26
	31	37.8	7.31	45.0	9.31	52.4	11.54	56.0	12.75	58.6	13.55	59.8	13.67	61.2	13.79
	33	37.8	7.76	45.0	9.91	52.4	12.30	56.0	13.61	57.6	14.06	59.0	14.18	60.4	14.31
	35	37.8	8.25	45.0	10.54	52.4	13.12	56.0	14.51	56.6	14.57	58.0	14.70	59.4	14.82
	37	37.8	8.78	45.0	11.22	52.4	13.98	55.0	15.02	55.8	15.10	57.2	15.23	58.4	15.35
	39	37.8	9.33	45.0	11.93	52.4	14.88	54.2	15.53	54.8	15.61	56.2	15.74	57.6	15.90
	43	37.8	10.20	45.0	12.80	52.4	15.71	52.5	15.82	54.0	16.00	55.6	16.22	55.8	16.41
	46	37.8	10.87	45.0	13.42	52.4	15.99	51.4	16.07	53.7	16.36	55.1	16.50	54.6	16.70
48	37.8	11.25	45.0	13.85	52.4	16.01	49.3	16.22	53.6	16.58	51.7	16.64	53.4	16.78	
75%	10	28.3	3.93	33.7	4.77	39.2	5.50	41.8	5.83	44.6	6.13	50.0	6.66	55.5	7.12
	12	28.3	4.01	33.7	4.84	39.2	5.58	41.8	5.90	44.6	6.20	50.0	6.74	55.5	7.19
	14	28.3	4.09	33.7	4.92	39.2	5.66	41.8	5.98	44.6	6.28	50.0	6.82	55.5	7.25
	16	28.3	4.16	33.7	5.00	39.2	5.73	41.8	6.06	44.6	6.36	50.0	6.89	55.5	7.32
	18	28.3	4.24	33.7	5.09	39.2	5.83	41.8	6.14	44.6	6.44	50.0	6.96	55.5	7.38
	20	28.3	4.32	33.7	5.17	39.2	5.90	41.8	6.23	44.6	6.52	50.0	7.03	55.5	7.66
	21	28.3	4.36	33.7	5.21	39.2	5.94	41.8	6.27	44.6	6.56	50.0	7.24	55.5	7.88
	23	28.3	4.44	33.7	5.30	39.2	6.11	41.8	6.53	44.6	6.94	50.0	7.67	55.5	8.35
	25	28.3	4.56	33.7	5.56	39.2	6.49	41.8	6.94	44.6	7.34	50.0	8.13	55.5	8.82
	27	28.3	4.84	33.7	5.90	39.2	6.89	41.8	7.34	44.6	7.77	50.0	8.59	55.5	9.30
	29	28.3	5.15	33.7	6.26	39.2	7.29	41.8	7.76	44.6	8.22	50.0	9.06	55.5	9.80
	31	28.3	5.46	33.7	6.62	39.2	7.70	41.8	8.19	44.6	8.68	50.0	9.54	55.5	10.32
	33	28.3	5.79	33.7	7.02	39.2	8.13	41.8	8.65	44.6	9.13	50.0	10.04	55.5	10.85
	35	28.3	6.13	33.7	7.41	39.2	8.57	41.8	9.11	44.6	9.62	50.0	10.56	55.5	11.37
	37	28.3	6.48	33.7	7.81	39.2	9.03	41.8	9.59	44.6	10.12	50.0	11.08	54.9	11.92
	39	28.3	6.85	33.7	8.25	39.2	9.50	41.8	10.08	44.6	10.63	50.0	11.62	54.0	12.48
	43	28.3	7.54	33.7	9.08	39.2	10.45	41.8	11.09	44.6	11.68	50.0	12.74	53.4	13.87
	46	28.3	7.74	33.7	9.32	39.2	10.74	41.8	11.40	44.6	12.01	50.0	13.13	53.0	14.12
48	28.3	8.01	33.7	9.65	39.2	11.12	41.8	11.79	44.6	12.45	50.0	13.58	52.1	14.47	
50%	10	18.8	2.80	22.4	2.79	26.0	2.77	27.7	3.03	29.8	3.37	33.4	3.98	37.0	4.53
	12	18.8	2.80	22.4	2.79	26.0	2.77	27.7	3.11	29.8	3.45	33.4	4.07	37.0	4.61
	14	18.8	2.80	22.4	2.80	26.0	2.83	27.7	3.20	29.8	3.54	33.4	4.16	37.0	4.70
	16	18.8	2.80	22.4	2.79	26.0	2.92	27.7	3.29	29.8	3.63	33.4	4.24	37.0	4.78
	18	18.8	2.80	22.4	2.88	26.0	3.01	27.7	3.38	29.8	3.72	33.4	4.33	37.0	4.87
	20	18.8	2.80	22.4	2.88	26.0	3.11	27.7	3.47	29.8	3.81	33.4	4.43	37.0	4.95
	21	18.8	2.80	22.4	2.88	26.0	3.16	27.7	3.52	29.8	3.86	33.4	4.48	37.0	5.00
	23	18.8	2.80	22.4	2.88	26.0	3.25	27.7	3.62	29.8	3.96	33.4	4.57	37.0	5.09
	25	18.8	2.80	22.4	2.88	26.0	3.35	27.7	3.72	29.8	4.10	33.4	4.81	37.0	5.42
	27	18.8	2.80	22.4	2.82	26.0	3.58	27.7	3.99	29.8	4.39	33.4	5.11	37.0	5.76
	29	18.8	2.91	22.4	2.92	26.0	3.84	27.7	4.27	29.8	4.67	33.4	5.43	37.0	6.10
	31	18.8	3.03	22.4	3.13	26.0	4.11	27.7	4.56	29.8	4.99	33.4	5.77	37.0	6.47
	33	18.8	3.14	22.4	3.38	26.0	4.39	27.7	4.86	29.8	5.30	33.4	6.11	37.0	6.83
	35	18.8	3.26	22.4	3.63	26.0	4.69	27.7	5.17	29.8	5.64	33.4	6.48	37.0	7.20
	37	18.8	3.37	22.4	3.90	26.0	5.00	27.7	5.50	29.8	5.98	33.4	6.85	37.0	7.59
	39	18.8	3.48	22.4	4.18	26.0	5.33	27.7	5.85	29.8	6.34	33.4	7.23	37.0	8.00
	43	18.8	3.83	22.4	4.60	26.0	5.86	27.7	6.44	29.8	6.97	33.4	7.93	37.0	8.89
	46	18.8	3.93	22.4	4.72	26.0	6.02	27.7	6.62	29.8	7.16	33.4	8.17	37.0	9.05
48	18.8	4.07	22.4	4.89	26.0	6.24	27.7	6.84	29.8	7.42	33.4	8.45	37.0	9.28	
25%	10	9.4	1.39	11.2	1.38	12.9	1.37	13.8	1.50	14.8	1.65	16.7	1.92	18.4	2.23
	12	9.4	1.39	11.2	1.38	12.9	1.37	13.8	1.54	14.8	1.69	16.7	1.96	18.4	2.27
	14	9.4	1.39	11.2	1.39	12.9	1.40	13.8	1.59	14.8	1.73	16.7	2.01	18.4	2.32
	16	9.4	1.39	11.2	1.38	12.9	1.45	13.8	1.63	14.8	1.78	16.7	2.04	18.4	2.36
	18	9.4	1.39	11.2	1.43	12.9	1.49	13.8	1.68	14.8	1.82	16.7	2.09	18.4	2.40
	20	9.4	1.39	11.2	1.43	12.9	1.54	13.8	1.72	14.8	1.86	16.7	2.14	18.4	2.44
	21	9.4	1.39	11.2	1.43	12.9	1.57	13.8	1.75	14.8	1.89	16.7	2.16	18.4	2.46
	23	9.4	1.39	11.2	1.43	12.9	1.61	13.8	1.80	14.8	1.94	16.7	2.20	18.4	2.51
	25	9.4	1.39	11.2	1.43	12.9	1.66	13.8	1.84	14.8	2.01	16.7	2.32	18.4	2.67
	27	9.4	1.39	11.2	1.40	12.9	1.78	13.8	1.98	14.8	2.15	16.7	2.46	18.4	2.84
	29	9.4	1.44	11.2	1.45	12.9	1.91	13.8	2.12	14.8	2.28	16.7	2.62	18.4	3.01
	31	9.4	1.50	11.2	1.55	12.9	2.04	13.8	2.26	14.8	2.44	16.7	2.78	18.4	3.19
	33	9.4	1.56	11.2	1.67	12.9	2.18	13.8	2.41	14.8	2.59	16.7	2.95	18.4	3.37
	35	9.4	1.62	11.2	1.80	12.9	2.33	13.8	2.56	14.8	2.76	16.7	3.12	18.4	3.55
	37	9.4	1.67	11.2	1.93	12.9	2.48	13.8	2.73	14.8	2.92	16.7	3.30	18.4	3.74
	39	9.4	1.72	11.2	2.07	12.9	2.64	13.8	2.90	14.8	3.10	16.7	3.49	18.4	3.94
	43	9.4	1.90	11.2	2.28	12.9	2.91	13.8	3.19	14.8	3.41	16.7	3.82	18.4	4.38
	46	9.4	1.95	11.2	2.34	12.9	2.99	13.8	3.28	14.8	3.50	16.7	3.94	18.4	4.46
48	9.4	2.02	11.2	2.42	12.9	3.09	13.8	3.39	14.8	3.63	16.7	4.07	18.4	4.57	

Abbreviations:

TC: Total capacity (kW)

PI: Power input (compressor + outdoor fan motor) (kW)

Table 2-8.25: VMEX020Q8A-D36V615 cooling part load performance

Part load	Outdoor air temp. (°C DB)	Indoor air temp. (°C WB)													
		14.0		16.0		18.0		19.0		20.0		22.0		24.0	
		TC kW	PI kW	TC kW	PI kW	TC kW	PI kW	TC kW	PI kW	TC kW	PI kW	TC kW	PI kW	TC kW	PI kW
100%	10	41.5	5.67	49.4	6.87	57.5	8.13	61.5	8.80	65.5	9.46	73.6	10.81	77.8	11.19
	12	41.5	5.76	49.4	7.00	57.5	8.29	61.5	8.95	65.5	9.64	73.6	11.01	76.7	11.28
	14	41.5	5.87	49.4	7.13	57.5	8.44	61.5	9.13	65.5	9.81	73.6	11.23	75.8	11.41
	16	41.5	5.98	49.4	7.27	57.5	8.62	61.5	9.31	65.5	10.02	73.1	11.37	74.7	11.54
	18	41.5	6.09	49.4	7.40	57.5	8.77	61.5	9.48	65.5	10.21	72.3	11.74	73.8	11.83
	20	41.5	6.20	49.4	7.56	57.5	9.04	61.5	9.97	65.5	10.95	71.2	12.30	72.7	12.41
	21	41.5	6.27	49.4	7.62	57.5	9.37	61.5	10.32	65.5	11.32	70.7	12.58	72.3	12.69
	23	41.5	6.42	49.4	8.13	57.5	10.04	61.5	11.06	65.5	12.14	69.8	13.16	71.2	13.27
	25	41.5	6.85	49.4	8.69	57.5	10.75	61.5	11.85	65.5	13.01	68.8	13.74	70.3	13.85
	27	41.5	7.31	49.4	9.26	57.5	11.48	61.5	12.67	65.5	13.91	67.7	14.31	69.2	14.45
	29	41.5	7.78	49.4	9.88	57.5	12.25	61.5	13.54	65.2	14.78	66.8	14.91	68.3	15.02
	31	41.5	8.29	49.4	10.55	57.5	13.07	61.5	14.45	64.4	15.35	65.7	15.49	67.2	15.62
	33	41.5	8.80	49.4	11.23	57.5	13.94	61.5	15.42	63.3	15.93	64.8	16.06	66.3	16.22
	35	41.5	9.35	49.4	11.94	57.5	14.87	61.5	16.44	62.2	16.51	63.7	16.66	65.2	16.80
	37	41.5	9.95	49.4	12.72	57.5	15.84	60.4	17.02	61.3	17.10	62.8	17.26	64.1	17.39
	39	41.5	10.57	49.4	13.52	57.5	16.86	59.5	17.59	60.2	17.68	61.7	17.84	63.3	18.01
	43	41.5	11.55	49.4	14.50	57.5	17.80	57.7	17.92	59.3	18.13	61.0	18.37	61.2	18.59
	46	41.5	12.21	49.4	15.16	57.5	18.11	56.4	18.17	59.0	18.45	60.5	18.66	60.0	18.84
48	41.5	12.75	49.4	15.69	57.5	18.13	54.1	18.38	58.9	18.78	56.8	18.85	58.7	19.01	
75%	10	31.0	4.47	37.1	5.42	43.1	6.25	45.9	6.62	48.9	6.97	55.0	7.58	61.0	8.10
	12	31.0	4.56	37.1	5.51	43.1	6.34	45.9	6.71	48.9	7.06	55.0	7.66	61.0	8.17
	14	31.0	4.65	37.1	5.60	43.1	6.43	45.9	6.80	48.9	7.14	55.0	7.75	61.0	8.24
	16	31.0	4.74	37.1	5.69	43.1	6.52	45.9	6.89	48.9	7.23	55.0	7.83	61.0	8.32
	18	31.0	4.82	37.1	5.79	43.1	6.62	45.9	6.98	48.9	7.32	55.0	7.92	61.0	8.39
	20	31.0	4.91	37.1	5.88	43.1	6.71	45.9	7.08	48.9	7.41	55.0	7.99	61.0	8.71
	21	31.0	4.96	37.1	5.92	43.1	6.76	45.9	7.13	48.9	7.46	55.0	8.23	61.0	8.96
	23	31.0	5.05	37.1	6.03	43.1	6.95	45.9	7.43	48.9	7.89	55.0	8.72	61.0	9.49
	25	31.0	5.18	37.1	6.33	43.1	7.38	45.9	7.89	48.9	8.35	55.0	9.24	61.0	10.03
	27	31.0	5.51	37.1	6.71	43.1	7.83	45.9	8.35	48.9	8.84	55.0	9.76	61.0	10.58
	29	31.0	5.85	37.1	7.11	43.1	8.29	45.9	8.82	48.9	9.35	55.0	10.30	61.0	11.14
	31	31.0	6.21	37.1	7.53	43.1	8.75	45.9	9.32	48.9	9.87	55.0	10.85	61.0	11.74
	33	31.0	6.58	37.1	7.98	43.1	9.24	45.9	9.84	48.9	10.39	55.0	11.41	61.0	12.33
	35	31.0	6.97	37.1	8.42	43.1	9.75	45.9	10.36	48.9	10.94	55.0	12.01	61.0	12.93
	37	31.0	7.37	37.1	8.88	43.1	10.27	45.9	10.91	48.9	11.50	55.0	12.60	60.3	13.55
	39	31.0	7.78	37.1	9.38	43.1	10.80	45.9	11.46	48.9	12.08	55.0	13.21	59.3	14.19
	43	31.0	8.56	37.1	10.32	43.1	11.88	45.9	12.61	48.9	13.27	55.0	14.48	58.5	15.77
	46	31.0	8.79	37.1	10.60	43.1	12.20	45.9	12.96	48.9	13.65	55.0	14.92	57.8	16.05
48	31.0	9.10	37.1	10.97	43.1	12.64	45.9	13.40	48.9	14.15	55.0	15.43	57.2	16.45	
50%	10	20.7	3.19	24.6	3.17	28.6	3.14	30.4	3.44	32.7	3.83	36.6	4.53	40.6	5.15
	12	20.7	3.19	24.6	3.17	28.6	3.14	30.4	3.53	32.7	3.92	36.6	4.63	40.6	5.24
	14	20.7	3.19	24.6	3.19	28.6	3.22	30.4	3.63	32.7	4.02	36.6	4.74	40.6	5.34
	16	20.7	3.19	24.6	3.17	28.6	3.32	30.4	3.74	32.7	4.13	36.6	4.82	40.6	5.43
	18	20.7	3.19	24.6	3.28	28.6	3.43	30.4	3.84	32.7	4.23	36.6	4.93	40.6	5.54
	20	20.7	3.19	24.6	3.28	28.6	3.53	30.4	3.95	32.7	4.33	36.6	5.03	40.6	5.63
	21	20.7	3.19	24.6	3.28	28.6	3.59	30.4	4.01	32.7	4.39	36.6	5.09	40.6	5.69
	23	20.7	3.19	24.6	3.28	28.6	3.69	30.4	4.11	32.7	4.50	36.6	5.20	40.6	5.79
	25	20.7	3.19	24.6	3.28	28.6	3.81	30.4	4.23	32.7	4.66	36.6	5.46	40.6	6.16
	27	20.7	3.19	24.6	3.20	28.6	4.07	30.4	4.54	32.7	4.99	36.6	5.81	40.6	6.55
	29	20.7	3.31	24.6	3.32	28.6	4.36	30.4	4.85	32.7	5.32	36.6	6.18	40.6	6.94
	31	20.7	3.44	24.6	3.56	28.6	4.68	30.4	5.18	32.7	5.67	36.6	6.56	40.6	7.35
	33	20.7	3.58	24.6	3.84	28.6	4.99	30.4	5.52	32.7	6.03	36.6	6.95	40.6	7.77
	35	20.7	3.71	24.6	4.13	28.6	5.33	30.4	5.88	32.7	6.42	36.6	7.37	40.6	8.19
	37	20.7	3.83	24.6	4.44	28.6	5.69	30.4	6.25	32.7	6.80	36.6	7.78	40.6	8.63
	39	20.7	3.96	24.6	4.75	28.6	6.06	30.4	6.65	32.7	7.20	36.6	8.22	40.6	9.09
	43	20.7	4.36	24.6	5.23	28.6	6.67	30.4	7.32	32.7	7.91	36.6	9.01	40.6	10.10
	46	20.7	4.47	24.6	5.37	28.6	6.85	30.4	7.52	32.7	8.13	36.6	9.29	40.6	10.28
48	20.7	4.63	24.6	5.56	28.6	7.09	30.4	7.78	32.7	8.43	36.6	9.60	40.6	10.54	
25%	10	10.3	1.52	12.3	1.51	14.3	1.52	15.2	1.66	16.3	1.84	18.2	2.17	20.2	2.52
	12	10.3	1.52	12.3	1.51	14.3	1.52	15.2	1.70	16.3	1.88	18.2	2.22	20.2	2.56
	14	10.3	1.52	12.3	1.52	14.3	1.54	15.2	1.75	16.3	1.93	18.2	2.27	20.2	2.61
	16	10.3	1.52	12.3	1.51	14.3	1.59	15.2	1.80	16.3	1.98	18.2	2.31	20.2	2.65
	18	10.3	1.52	12.3	1.57	14.3	1.64	15.2	1.85	16.3	2.03	18.2	2.36	20.2	2.71
	20	10.3	1.52	12.3	1.57	14.3	1.69	15.2	1.91	16.3	2.08	18.2	2.41	20.2	2.75
	21	10.3	1.52	12.3	1.57	14.3	1.72	15.2	1.93	16.3	2.11	18.2	2.44	20.2	2.78
	23	10.3	1.52	12.3	1.57	14.3	1.77	15.2	1.98	16.3	2.16	18.2	2.49	20.2	2.83
	25	10.3	1.52	12.3	1.57	14.3	1.82	15.2	2.04	16.3	2.24	18.2	2.62	20.2	3.01
	27	10.3	1.52	12.3	1.53	14.3	1.95	15.2	2.19	16.3	2.39	18.2	2.79	20.2	3.20
	29	10.3	1.57	12.3	1.59	14.3	2.09	15.2	2.34	16.3	2.55	18.2	2.96	20.2	3.39
	31	10.3	1.64	12.3	1.70	14.3	2.24	15.2	2.50	16.3	2.72	18.2	3.15	20.2	3.59
	33	10.3	1.70	12.3	1.83	14.3	2.39	15.2	2.66	16.3	2.89	18.2	3.33	20.2	3.80
	35	10.3	1.76	12.3	1.97	14.3	2.55	15.2	2.84	16.3	3.08	18.2	3.53	20.2	4.00
	37	10.3	1.82	12.3	2.12	14.3	2.72	15.2	3.02	16.3	3.26	18.2	3.73	20.2	4.22
	39	10.3	1.88	12.3	2.27	14.3	2.90	15.2	3.21	16.3	3.45	18.2	3.94	20.2	4.44
	43	10.3	2.07	12.3	2.50	14.3	3.19	15.2	3.53	16.3	3.79	18.2	4.32	20.2	4.94
	46	10.3	2.13	12.3	2.56	14.3	3.28	15.2	3.63	16.3	3.90	18.2	4.45	20.2	5.02
48	10.3	2.20	12.3	2.65	14.3	3.39	15.2	3.75	16.3	4.04	18.2	4.61	20.2	5.15	

Abbreviations:

TC: Total capacity (kW)

PI: Power input (compressor + outdoor fan motor) (kW)

# VMEX 460V 60Hz

## 8.6 Heating Part Load Performance at 100% Combination Ratio

Table 2-8.26: VMEX008Q8A-D13V224 heating part load performance

Part load	Outdoor air temp.		Indoor air temp. (°C DB)											
			16.0		18.0		20.0		21.0		22.0		24.0	
	(°C DB)	(°C WB)	TC kW	PI kW	TC kW	PI kW	TC kW	PI kW	TC kW	PI kW	TC kW	PI kW	TC kW	PI kW
100%	-19.8	-20.0	17.2	4.38	17.1	4.56	17.1	4.75	17.1	4.85	17.1	4.93	17.0	5.12
	-18.8	-19.0	17.5	4.44	17.5	4.62	17.4	4.80	17.4	4.90	17.3	4.99	17.3	5.17
	-16.7	-17.0	18.2	4.56	18.1	4.74	18.1	4.91	18.0	5.00	18.0	5.09	18.0	5.26
	-13.7	-15.0	18.9	4.69	18.9	4.86	18.8	5.03	18.8	5.12	18.8	5.20	18.7	5.37
	-11.8	-13.0	19.7	4.83	19.7	4.99	19.6	5.15	19.6	5.23	19.6	5.31	19.5	5.48
	-9.8	-11.0	20.7	4.96	20.6	5.12	20.6	5.27	20.6	5.35	20.5	5.43	20.5	5.58
	-9.5	-10.0	21.2	5.03	21.1	5.18	21.1	5.33	21.0	5.41	21.0	5.48	20.9	5.63
	-8.5	-9.1	21.6	5.09	21.5	5.24	21.5	5.38	21.5	5.46	21.4	5.53	21.4	5.68
	-7.0	-7.6	22.4	5.19	22.4	5.33	22.3	5.47	22.3	5.55	22.3	5.61	22.2	5.76
	-5.0	-5.6	23.6	5.32	23.5	5.45	23.5	5.59	23.4	5.65	23.4	5.72	23.3	5.86
	-3.0	-3.7	24.7	5.44	24.7	5.49	24.6	5.70	24.6	5.76	24.6	5.82	23.6	5.58
	0.0	-0.7	26.7	5.61	26.7	5.73	26.6	5.85	26.1	5.76	25.3	5.52	23.6	5.06
	3.0	2.2	28.8	5.78	28.7	5.88	27.0	5.45	26.1	5.23	25.3	5.03	23.6	4.61
	5.0	4.1	30.3	5.88	28.7	5.53	27.0	5.12	26.1	4.93	25.3	4.73	23.6	4.35
	7.0	6.0	30.4	5.58	28.7	5.20	27.0	4.82	26.1	4.64	25.3	4.46	23.6	4.10
	9.0	7.9	30.4	5.25	28.7	4.89	27.0	4.54	26.1	4.31	25.3	4.20	23.6	3.87
	11.0	9.8	30.4	4.94	28.7	4.61	27.0	4.28	26.1	4.12	25.3	3.96	23.6	3.66
13.0	11.8	30.4	4.64	28.7	4.33	27.0	4.03	26.1	3.88	25.3	3.74	23.6	3.45	
15.0	13.7	30.4	4.38	28.7	4.09	27.0	3.81	26.1	3.67	25.3	3.53	23.6	3.27	
75%	-19.8	-20.0	16.6	6.10	16.5	6.27	16.5	6.44	16.5	6.51	16.4	6.64	16.4	6.77
	-18.8	-19.0	16.9	6.15	16.9	6.32	16.8	6.49	16.8	6.57	16.8	6.64	16.7	6.83
	-16.7	-17.0	17.5	6.27	17.5	6.44	17.4	6.57	17.4	6.70	17.4	6.77	17.4	6.90
	-13.7	-15.0	18.3	6.40	18.2	6.57	18.2	6.70	18.2	6.77	18.2	6.83	17.6	6.70
	-11.8	-13.0	19.1	6.51	19.1	6.64	19.0	6.83	19.0	6.90	18.9	6.90	17.6	6.32
	-9.8	-11.0	20.0	6.64	20.0	6.77	20.0	6.90	19.5	6.77	18.9	6.51	17.6	5.97
	-9.5	-10.0	20.5	6.70	20.5	6.83	20.2	6.83	19.5	6.57	18.9	6.32	17.6	5.80
	-8.5	-9.1	20.9	6.77	20.9	6.90	20.2	6.70	19.5	6.41	18.9	6.15	17.6	5.65
	-7.0	-7.6	21.7	6.83	21.5	6.90	20.2	6.38	19.5	6.13	18.9	5.88	17.6	5.41
	-5.0	-5.6	22.8	6.96	21.5	6.47	20.2	6.00	19.5	5.76	18.9	5.54	17.6	5.10
	-3.0	-3.7	22.8	6.57	21.5	6.10	20.2	5.66	19.5	5.44	18.9	5.23	17.6	4.17
	0.0	-0.7	22.8	5.95	21.5	5.56	20.2	5.16	19.5	4.82	18.9	4.13	17.6	3.80
	3.0	2.2	22.8	5.44	21.5	5.08	20.2	4.09	19.5	3.94	18.9	3.78	17.6	3.49
	5.0	4.1	22.8	5.13	21.5	4.15	20.2	3.86	19.5	3.72	18.9	3.57	17.6	3.29
	7.0	6.0	22.8	4.19	21.5	3.91	20.2	3.65	19.5	3.51	18.9	3.38	17.6	3.12
	9.0	7.9	22.8	3.96	21.5	3.70	20.2	3.44	19.5	3.32	18.9	3.20	17.6	2.85
	11.0	9.8	22.8	3.74	21.5	3.50	20.2	3.25	19.5	3.14	18.9	2.97	17.6	2.60
13.0	11.8	22.8	3.52	21.5	3.30	20.2	3.05	19.5	2.88	18.9	2.70	17.6	2.35	
15.0	13.7	22.8	3.33	21.5	3.12	20.2	2.79	19.5	2.62	18.9	2.46	17.6	2.22	
50%	-19.8	-20.0	15.2	6.32	14.3	5.89	13.5	5.47	13.0	5.26	12.5	5.06	11.7	4.03
	-18.8	-19.0	15.2	6.18	14.3	5.76	13.5	5.35	13.0	5.15	12.5	4.77	11.7	3.94
	-16.7	-17.0	15.2	5.89	14.3	5.49	13.5	5.11	13.0	4.59	12.5	4.09	11.7	3.76
	-13.7	-15.0	15.2	5.59	14.3	5.22	13.5	4.30	13.0	4.04	12.5	3.89	11.7	3.58
	-11.8	-13.0	15.2	5.31	14.3	4.77	13.5	3.98	13.0	3.83	12.5	3.69	11.7	3.40
	-9.8	-11.0	15.2	5.02	14.3	4.06	13.5	3.78	13.0	3.63	12.5	3.50	11.7	3.23
	-9.5	-10.0	15.2	4.41	14.3	3.94	13.5	3.67	13.0	3.53	12.5	3.40	11.7	3.14
	-8.5	-9.1	15.2	4.12	14.3	3.85	13.5	3.58	13.0	3.45	12.5	3.32	11.7	3.04
	-7.0	-7.6	15.2	3.94	14.3	3.68	13.5	3.43	13.0	3.31	12.5	3.18	11.7	2.84
	-5.0	-5.6	15.2	3.72	14.3	3.48	13.5	3.24	13.0	3.12	12.5	2.95	11.7	2.58
	-3.0	-3.7	15.2	3.51	14.3	3.29	13.5	3.04	13.0	2.86	12.5	2.69	11.7	2.35
	0.0	-0.7	15.2	3.21	14.3	2.95	13.5	2.63	13.0	2.47	12.5	2.33	11.7	2.13
	3.0	2.2	15.2	2.86	14.3	2.56	13.5	2.30	13.0	2.21	12.5	2.12	11.7	1.94
	5.0	4.1	15.2	2.61	14.3	2.33	13.5	2.17	13.0	2.08	12.5	2.00	11.7	1.83
	7.0	6.0	15.2	2.36	14.3	2.20	13.5	2.04	13.0	1.96	12.5	1.88	11.7	1.73
	9.0	7.9	15.2	2.22	14.3	2.07	13.5	1.92	13.0	1.85	12.5	1.77	11.7	1.62
	11.0	9.8	15.2	2.09	14.3	1.95	13.5	1.81	13.0	1.74	12.5	1.67	11.7	1.53
13.0	11.8	15.2	1.97	14.3	1.83	13.5	1.70	13.0	1.64	12.5	1.57	11.7	1.44	
15.0	13.7	15.2	1.85	14.3	1.73	13.5	1.60	13.0	1.55	12.5	1.48	11.7	1.36	
25%	-19.8	-20.0	7.6	3.07	7.1	2.90	6.7	2.71	6.5	2.61	6.2	2.46	5.8	1.96
	-18.8	-19.0	7.6	3.00	7.1	2.83	6.7	2.66	6.5	2.55	6.2	2.32	5.8	1.92
	-16.7	-17.0	7.6	2.86	7.1	2.70	6.7	2.54	6.5	2.27	6.2	1.99	5.8	1.83
	-13.7	-15.0	7.6	2.72	7.1	2.57	6.7	2.13	6.5	2.00	6.2	1.89	5.8	1.74
	-11.8	-13.0	7.6	2.58	7.1	2.35	6.7	1.98	6.5	1.90	6.2	1.80	5.8	1.65
	-9.8	-11.0	7.6	2.44	7.1	2.00	6.7	1.88	6.5	1.80	6.2	1.70	5.8	1.57
	-9.5	-10.0	7.6	2.14	7.1	1.94	6.7	1.82	6.5	1.75	6.2	1.65	5.8	1.53
	-8.5	-9.1	7.6	2.00	7.1	1.89	6.7	1.78	6.5	1.71	6.2	1.62	5.8	1.48
	-7.0	-7.6	7.6	1.91	7.1	1.81	6.7	1.70	6.5	1.64	6.2	1.55	5.8	1.38
	-5.0	-5.6	7.6	1.81	7.1	1.71	6.7	1.61	6.5	1.55	6.2	1.44	5.8	1.26
	-3.0	-3.7	7.6	1.71	7.1	1.62	6.7	1.51	6.5	1.42	6.2	1.31	5.8	1.14
	0.0	-0.7	7.6	1.56	7.1	1.45	6.7	1.31	6.5	1.22	6.2	1.13	5.8	1.04
	3.0	2.2	7.6	1.39	7.1	1.26	6.7	1.14	6.5	1.09	6.2	1.03	5.8	0.94
	5.0	4.1	7.6	1.27	7.1	1.15	6.7	1.08	6.5	1.03	6.2	0.97	5.8	0.89
	7.0	6.0	7.6	1.15	7.1	1.08	6.7	1.01	6.5	0.97	6.2	0.92	5.8	0.84
	9.0	7.9	7.6	1.08	7.1	1.02	6.7	0.95	6.5	0.92	6.2	0.86	5.8	0.79
	11.0	9.8	7.6	1.02	7.1	0.96	6.7	0.90	6.5	0.86	6.2	0.81	5.8	0.74
13.0	11.8	7.6	0.96	7.1	0.90	6.7	0.84	6.5	0.81	6.2	0.76	5.8	0.70	
15.0	13.7	7.6	0.90	7.1	0.85	6.7	0.79	6.5	0.77	6.2	0.72	5.8	0.66	

Abbreviations:

TC: Total capacity (kW)

PI: Power input (compressor + outdoor fan motor) (kW)



Table 2-8.27: VMEX009Q8A-D16V280 heating part load performance

Part load	Outdoor air temp.		Indoor air temp. (°C DB)											
			16.0		18.0		20.0		21.0		22.0		24.0	
	(°C DB)	(°C WB)	TC kW	PI kW	TC kW	PI kW	TC kW	PI kW	TC kW	PI kW	TC kW	PI kW	TC kW	PI kW
100%	-19.8	-20.0	20.1	5.40	20.0	5.62	20.0	5.86	19.9	5.97	19.9	6.08	19.8	6.31
	-18.8	-19.0	20.4	5.47	20.4	5.69	20.3	5.92	20.3	6.03	20.2	6.15	20.2	6.37
	-16.7	-17.0	21.2	5.62	21.1	5.84	21.1	6.06	21.0	6.16	21.0	6.27	21.0	6.49
	-13.7	-15.0	22.1	5.79	22.0	5.99	21.9	6.20	21.9	6.31	21.9	6.41	21.8	6.62
	-11.8	-13.0	23.0	5.96	23.0	6.15	22.9	6.35	22.9	6.45	22.9	6.55	22.8	6.75
	-9.8	-11.0	24.1	6.12	24.0	6.31	24.0	6.50	24.0	6.60	23.9	6.69	23.9	6.87
	-9.5	-10.0	24.7	6.20	24.6	6.39	24.6	6.57	24.5	6.67	24.5	6.76	24.4	6.94
	-8.5	-9.1	25.2	6.27	25.1	6.46	25.1	6.63	25.1	6.73	25.0	6.82	25.0	7.00
	-7.0	-7.6	26.1	6.40	26.1	6.57	26.0	6.74	26.0	6.83	26.0	6.92	25.9	7.10
	-5.0	-5.6	27.5	6.56	27.4	6.72	27.4	6.89	27.3	6.97	27.3	7.05	27.2	7.22
	-3.0	-3.7	28.8	6.70	28.8	6.09	28.7	7.02	28.7	7.10	28.7	7.17	27.5	6.87
	0.0	-0.7	31.1	6.92	31.1	7.07	31.0	7.21	30.5	7.10	29.5	6.80	27.5	6.24
	3.0	2.2	33.6	7.12	33.5	7.25	31.5	6.71	30.5	6.45	29.5	6.19	27.5	5.69
	5.0	4.1	35.3	7.25	33.5	6.81	31.5	6.31	30.5	6.07	29.5	5.83	27.5	5.36
	7.0	6.0	35.5	6.88	33.5	6.40	31.5	5.94	30.5	5.72	29.5	5.49	27.5	5.05
	9.0	7.9	35.5	6.46	33.5	6.02	31.5	5.59	30.5	5.32	29.5	5.18	27.5	4.77
	11.0	9.8	35.5	6.09	33.5	5.68	31.5	5.28	30.5	5.08	29.5	4.88	27.5	4.50
13.0	11.8	35.5	5.72	33.5	5.34	31.5	4.97	30.5	4.78	29.5	4.61	27.5	4.25	
15.0	13.7	35.5	5.39	33.5	5.04	31.5	4.69	30.5	4.52	29.5	4.35	27.5	4.03	
75%	-19.8	-20.0	19.3	7.50	19.3	7.71	19.3	7.92	19.3	8.00	19.2	8.16	19.2	8.32
	-18.8	-19.0	19.7	7.57	19.7	7.78	19.6	7.98	19.6	8.08	19.6	8.16	19.5	8.40
	-16.7	-17.0	20.4	7.71	20.4	7.91	20.3	8.08	20.3	8.24	20.3	8.32	20.3	8.48
	-13.7	-15.0	21.4	7.86	21.3	8.08	21.3	8.24	21.2	8.32	21.2	8.40	20.5	8.24
	-11.8	-13.0	22.3	8.00	22.3	8.16	22.2	8.40	22.2	8.48	22.0	8.48	20.5	7.78
	-9.8	-11.0	23.4	8.16	23.3	8.32	23.3	8.48	22.8	8.32	22.0	8.00	20.5	7.34
	-9.5	-10.0	23.9	8.24	23.9	8.40	23.5	8.40	22.8	8.08	22.0	7.77	20.5	7.14
	-8.5	-9.1	24.4	8.32	24.4	8.48	23.5	8.24	22.8	7.88	22.0	7.57	20.5	6.95
	-7.0	-7.6	25.3	8.40	25.1	8.48	23.5	7.84	22.8	7.54	22.0	7.23	20.5	6.65
	-5.0	-5.6	26.6	8.56	25.1	7.95	23.5	7.38	22.8	7.09	22.0	6.81	20.5	6.27
	-3.0	-3.7	26.6	8.08	25.1	7.50	23.5	6.96	22.8	6.69	22.0	6.43	20.5	5.12
	0.0	-0.7	26.6	7.32	25.1	6.83	23.5	6.35	22.8	5.92	22.0	5.08	20.5	4.67
	3.0	2.2	26.6	6.69	25.1	6.25	23.5	5.03	22.8	4.84	22.0	4.65	20.5	4.29
	5.0	4.1	26.6	6.31	25.1	5.11	23.5	4.75	22.8	4.57	22.0	4.39	20.5	4.05
	7.0	6.0	26.6	5.16	25.1	4.81	23.5	4.48	22.8	4.31	22.0	4.15	20.5	3.83
	9.0	7.9	26.6	4.87	25.1	4.55	23.5	4.23	22.8	4.08	22.0	3.93	20.5	3.50
	11.0	9.8	26.6	4.59	25.1	4.30	23.5	4.00	22.8	3.86	22.0	3.65	20.5	3.19
13.0	11.8	26.6	4.33	25.1	4.06	23.5	3.74	22.8	3.54	22.0	3.32	20.5	2.90	
15.0	13.7	26.6	4.10	25.1	3.84	23.5	3.43	22.8	3.22	22.0	3.02	20.5	2.73	
50%	-19.8	-20.0	17.7	7.78	16.7	7.24	15.7	6.73	15.1	6.47	14.6	6.22	13.6	4.95
	-18.8	-19.0	17.7	7.60	16.7	7.08	15.7	6.57	15.1	6.33	14.6	5.87	13.6	4.85
	-16.7	-17.0	17.7	7.24	16.7	6.75	15.7	6.28	15.1	5.64	14.6	5.03	13.6	4.63
	-13.7	-15.0	17.7	6.88	16.7	6.42	15.7	5.29	15.1	4.97	14.6	4.78	13.6	4.40
	-11.8	-13.0	17.7	6.53	16.7	5.87	15.7	4.90	15.1	4.71	14.6	4.54	13.6	4.19
	-9.8	-11.0	17.7	6.17	16.7	4.99	15.7	4.64	15.1	4.47	14.6	4.30	13.6	3.97
	-9.5	-10.0	17.7	5.43	16.7	4.85	15.7	4.51	15.1	4.35	14.6	4.19	13.6	3.86
	-8.5	-9.1	17.7	5.07	16.7	4.73	15.7	4.40	15.1	4.24	14.6	4.08	13.6	3.74
	-7.0	-7.6	17.7	4.85	16.7	4.53	15.7	4.22	15.1	4.07	14.6	3.91	13.6	3.49
	-5.0	-5.6	17.7	4.57	16.7	4.27	15.7	3.99	15.1	3.84	14.6	3.62	13.6	3.17
	-3.0	-3.7	17.7	4.32	16.7	4.04	15.7	3.74	15.1	3.52	14.6	3.30	13.6	2.89
	0.0	-0.7	17.7	3.95	16.7	3.63	15.7	3.23	15.1	3.04	14.6	2.86	13.6	2.62
	3.0	2.2	17.7	3.52	16.7	3.15	15.7	2.83	15.1	2.72	14.6	2.61	13.6	2.39
	5.0	4.1	17.7	3.21	16.7	2.87	15.7	2.66	15.1	2.56	14.6	2.45	13.6	2.25
	7.0	6.0	17.7	2.90	16.7	2.70	15.7	2.50	15.1	2.41	14.6	2.31	13.6	2.13
	9.0	7.9	17.7	2.73	16.7	2.54	15.7	2.36	15.1	2.27	14.6	2.18	13.6	2.00
	11.0	9.8	17.7	2.57	16.7	2.40	15.7	2.22	15.1	2.14	14.6	2.05	13.6	1.89
13.0	11.8	17.7	2.42	16.7	2.25	15.7	2.09	15.1	2.01	14.6	1.93	13.6	1.77	
15.0	13.7	17.7	2.28	16.7	2.13	15.7	1.97	15.1	1.90	14.6	1.82	13.6	1.68	
25%	-19.8	-20.0	8.8	3.76	8.3	3.46	7.8	3.28	7.5	3.12	7.3	3.02	6.8	2.43
	-18.8	-19.0	8.8	3.67	8.3	3.39	7.8	3.20	7.5	3.06	7.3	2.85	6.8	2.38
	-16.7	-17.0	8.8	3.50	8.3	3.23	7.8	3.06	7.5	2.72	7.3	2.44	6.8	2.27
	-13.7	-15.0	8.8	3.32	8.3	3.07	7.8	2.58	7.5	2.40	7.3	2.32	6.8	2.16
	-11.8	-13.0	8.8	3.16	8.3	2.81	7.8	2.39	7.5	2.27	7.3	2.21	6.8	2.06
	-9.8	-11.0	8.8	2.98	8.3	2.39	7.8	2.26	7.5	2.16	7.3	2.09	6.8	1.95
	-9.5	-10.0	8.8	2.62	8.3	2.32	7.8	2.20	7.5	2.10	7.3	2.04	6.8	1.89
	-8.5	-9.1	8.8	2.45	8.3	2.26	7.8	2.15	7.5	2.05	7.3	1.98	6.8	1.84
	-7.0	-7.6	8.8	2.34	8.3	2.17	7.8	2.06	7.5	1.96	7.3	1.90	6.8	1.71
	-5.0	-5.6	8.8	2.21	8.3	2.04	7.8	1.95	7.5	1.85	7.3	1.76	6.8	1.56
	-3.0	-3.7	8.8	2.09	8.3	1.93	7.8	1.82	7.5	1.70	7.3	1.60	6.8	1.42
	0.0	-0.7	8.8	1.91	8.3	1.74	7.8	1.57	7.5	1.47	7.3	1.39	6.8	1.29
	3.0	2.2	8.8	1.70	8.3	1.51	7.8	1.38	7.5	1.31	7.3	1.27	6.8	1.17
	5.0	4.1	8.8	1.55	8.3	1.37	7.8	1.30	7.5	1.24	7.3	1.19	6.8	1.10
	7.0	6.0	8.8	1.40	8.3	1.29	7.8	1.22	7.5	1.16	7.3	1.12	6.8	1.05
	9.0	7.9	8.8	1.32	8.3	1.22	7.8	1.15	7.5	1.10	7.3	1.06	6.8	0.98
	11.0	9.8	8.8	1.24	8.3	1.15	7.8	1.08	7.5	1.03	7.3	1.00	6.8	0.93
13.0	11.8	8.8	1.17	8.3	1.08	7.8	1.02	7.5	0.97	7.3	0.94	6.8	0.87	
15.0	13.7	8.8	1.10	8.3	1.02	7.8	0.96	7.5	0.92	7.3	0.88	6.8	0.82	

Abbreviations:

TC: Total capacity (kW)

PI: Power input (compressor + outdoor fan motor) (kW)

# VMEX 460V 60Hz

Table 2-8.28: VMEX010Q8A-D20V335 heating part load

Part load	Outdoor air temp.		Indoor air temp. (°C DB)											
			16.0		18.0		20.0		21.0		22.0		24.0	
	(°C DB)	(°C WB)	TC kW	PI kW	TC kW	PI kW	TC kW	PI kW	TC kW	PI kW	TC kW	PI kW	TC kW	PI kW
100%	-19.8	-20.0	23.9	6.95	23.8	7.24	23.8	7.54	23.7	7.69	23.7	7.83	23.6	8.13
	-18.8	-19.0	24.3	7.04	24.3	7.33	24.2	7.62	24.2	7.77	24.0	7.92	24.0	8.21
	-16.7	-17.0	25.2	7.24	25.1	7.52	25.1	7.80	25.0	7.94	25.0	8.08	25.0	8.36
	-13.7	-15.0	26.3	7.45	26.2	7.72	26.1	7.99	26.1	8.13	26.1	8.26	26.0	8.52
	-11.8	-13.0	27.4	7.67	27.4	7.92	27.3	8.18	27.3	8.31	27.3	8.43	27.1	8.69
	-9.8	-11.0	28.7	7.88	28.6	8.13	28.6	8.37	28.6	8.49	28.5	8.61	28.5	8.85
	-9.5	-10.0	29.4	7.99	29.3	8.23	29.3	8.46	29.2	8.58	29.2	8.70	29.0	8.94
	-8.5	-9.1	30.0	8.08	29.9	8.32	29.9	8.54	29.9	8.66	29.8	8.78	29.8	9.01
	-7.0	-7.6	31.1	8.24	31.1	8.46	31.0	8.68	31.0	8.80	31.0	8.91	30.8	9.14
	-5.0	-5.6	32.7	8.44	32.6	8.65	32.6	8.87	32.5	8.97	32.5	9.08	32.4	9.30
	-3.0	-3.7	34.3	8.63	34.3	7.84	34.2	9.04	34.2	9.14	34.2	9.24	32.7	8.85
	0.0	-0.7	37.0	8.91	37.0	9.10	36.9	9.29	36.3	9.14	35.1	8.76	32.7	8.04
	3.0	2.2	40.0	9.17	39.9	9.34	37.5	8.64	36.3	8.31	35.1	7.98	32.7	7.32
	5.0	4.1	42.0	9.34	39.9	8.77	37.5	8.13	36.3	7.82	35.1	7.51	32.7	6.90
	7.0	6.0	42.3	8.86	39.9	8.25	37.5	7.65	36.3	7.36	35.1	7.07	32.7	6.51
	9.0	7.9	42.3	8.33	39.9	7.76	37.5	7.20	36.3	6.85	35.1	6.67	32.7	6.14
	11.0	9.8	42.3	7.84	39.9	7.31	37.5	6.80	36.3	6.54	35.1	6.29	32.7	5.80
13.0	11.8	42.3	7.36	39.9	6.88	37.5	6.40	36.3	6.16	35.1	5.93	32.7	5.47	
15.0	13.7	42.3	6.94	39.9	6.49	37.5	6.04	36.3	5.82	35.1	5.60	32.7	5.19	
75%	-19.8	-20.0	23.0	9.29	22.9	9.55	22.9	9.81	22.9	9.91	22.8	10.11	22.8	10.31
	-18.8	-19.0	23.4	9.38	23.4	9.63	23.3	9.89	23.3	10.01	23.3	10.11	23.2	10.41
	-16.7	-17.0	24.3	9.55	24.3	9.80	24.2	10.01	24.2	10.21	24.2	10.31	24.1	10.51
	-13.7	-15.0	25.4	9.74	25.3	10.01	25.3	10.21	25.2	10.31	25.2	10.41	24.4	10.21
	-11.8	-13.0	26.5	9.91	26.5	10.11	26.4	10.41	26.4	10.51	26.2	10.51	24.4	9.63
	-9.8	-11.0	27.8	10.11	27.7	10.31	27.7	10.51	27.1	10.31	26.2	9.91	24.4	9.10
	-9.5	-10.0	28.4	10.21	28.4	10.41	28.0	10.41	27.1	10.01	26.2	9.62	24.4	8.84
	-8.5	-9.1	29.0	10.31	29.0	10.51	28.0	10.21	27.1	9.76	26.2	9.38	24.4	8.61
	-7.0	-7.6	30.1	10.41	29.8	10.51	28.0	9.71	27.1	9.34	26.2	8.96	24.4	8.23
	-5.0	-5.6	31.6	10.61	29.8	9.85	28.0	9.14	27.1	8.78	26.2	8.44	24.4	7.77
	-3.0	-3.7	31.6	10.01	29.8	9.29	28.0	8.62	27.1	8.29	26.2	7.97	24.4	6.35
	0.0	-0.7	31.6	9.07	29.8	8.46	28.0	7.87	27.1	7.34	26.2	6.30	24.4	5.79
	3.0	2.2	31.6	8.28	29.8	7.74	28.0	6.23	27.1	6.00	26.2	5.76	24.4	5.31
	5.0	4.1	31.6	7.82	29.8	6.33	28.0	5.88	27.1	5.66	26.2	5.44	24.4	5.02
	7.0	6.0	31.6	6.39	29.8	5.96	28.0	5.55	27.1	5.34	26.2	5.15	24.4	4.75
	9.0	7.9	31.6	6.03	29.8	5.63	28.0	5.24	27.1	5.06	26.2	4.87	24.4	4.34
	11.0	9.8	31.6	5.69	29.8	5.32	28.0	4.96	27.1	4.78	26.2	4.52	24.4	3.95
13.0	11.8	31.6	5.36	29.8	5.03	28.0	4.64	27.1	4.38	26.2	4.11	24.4	3.59	
15.0	13.7	31.6	5.08	29.8	4.76	28.0	4.25	27.1	3.99	26.2	3.75	24.4	3.38	
50%	-19.8	-20.0	21.1	9.63	19.9	8.97	18.7	8.33	18.0	8.02	17.4	7.71	16.2	6.14
	-18.8	-19.0	21.1	9.42	19.9	8.77	18.7	8.14	18.0	7.85	17.4	7.27	16.2	6.01
	-16.7	-17.0	21.1	8.97	19.9	8.36	18.7	7.78	18.0	6.99	17.4	6.23	16.2	5.73
	-13.7	-15.0	21.1	8.52	19.9	7.96	18.7	6.56	18.0	6.16	17.4	5.92	16.2	5.45
	-11.8	-13.0	21.1	8.08	19.9	7.27	18.7	6.07	18.0	5.84	17.4	5.62	16.2	5.19
	-9.8	-11.0	21.1	7.65	19.9	6.18	18.7	5.75	18.0	5.53	17.4	5.32	16.2	4.92
	-9.5	-10.0	21.1	6.72	19.9	6.01	18.7	5.59	18.0	5.38	17.4	5.19	16.2	4.79
	-8.5	-9.1	21.1	6.28	19.9	5.86	18.7	5.45	18.0	5.25	17.4	5.06	16.2	4.63
	-7.0	-7.6	21.1	6.01	19.9	5.61	18.7	5.22	18.0	5.04	17.4	4.85	16.2	4.32
	-5.0	-5.6	21.1	5.66	19.9	5.29	18.7	4.94	18.0	4.76	17.4	4.49	16.2	3.92
	-3.0	-3.7	21.1	5.35	19.9	5.01	18.7	4.63	18.0	4.36	17.4	4.09	16.2	3.58
	0.0	-0.7	21.1	4.90	19.9	4.50	18.7	4.00	18.0	3.77	17.4	3.55	16.2	3.25
	3.0	2.2	21.1	4.36	19.9	3.90	18.7	3.51	18.0	3.37	17.4	3.23	16.2	2.96
	5.0	4.1	21.1	3.97	19.9	3.56	18.7	3.30	18.0	3.17	17.4	3.04	16.2	2.79
	7.0	6.0	21.1	3.60	19.9	3.35	18.7	3.10	18.0	2.98	17.4	2.86	16.2	2.63
	9.0	7.9	21.1	3.39	19.9	3.15	18.7	2.92	18.0	2.81	17.4	2.70	16.2	2.47
	11.0	9.8	21.1	3.19	19.9	2.97	18.7	2.75	18.0	2.65	17.4	2.54	16.2	2.34
13.0	11.8	21.1	3.00	19.9	2.79	18.7	2.59	18.0	2.49	17.4	2.39	16.2	2.20	
15.0	13.7	21.1	2.82	19.9	2.63	18.7	2.44	18.0	2.36	17.4	2.26	16.2	2.08	
25%	-19.8	-20.0	10.5	4.73	9.9	4.41	9.3	4.07	9.0	3.91	8.7	3.79	8.1	3.02
	-18.8	-19.0	10.5	4.63	9.9	4.31	9.3	3.97	9.0	3.83	8.7	3.58	8.1	2.95
	-16.7	-17.0	10.5	4.41	9.9	4.11	9.3	3.80	9.0	3.41	8.7	3.07	8.1	2.82
	-13.7	-15.0	10.5	4.18	9.9	3.91	9.3	3.20	9.0	3.01	8.7	2.91	8.1	2.68
	-11.8	-13.0	10.5	3.97	9.9	3.57	9.3	2.96	9.0	2.85	8.7	2.77	8.1	2.55
	-9.8	-11.0	10.5	3.76	9.9	3.04	9.3	2.81	9.0	2.70	8.7	2.62	8.1	2.42
	-9.5	-10.0	10.5	3.30	9.9	2.95	9.3	2.73	9.0	2.62	8.7	2.55	8.1	2.35
	-8.5	-9.1	10.5	3.08	9.9	2.88	9.3	2.66	9.0	2.56	8.7	2.49	8.1	2.28
	-7.0	-7.6	10.5	2.95	9.9	2.76	9.3	2.55	9.0	2.46	8.7	2.39	8.1	2.12
	-5.0	-5.6	10.5	2.78	9.9	2.60	9.3	2.41	9.0	2.32	8.7	2.21	8.1	1.93
	-3.0	-3.7	10.5	2.63	9.9	2.46	9.3	2.26	9.0	2.13	8.7	2.01	8.1	1.76
	0.0	-0.7	10.5	2.41	9.9	2.21	9.3	1.95	9.0	1.84	8.7	1.75	8.1	1.60
	3.0	2.2	10.5	2.14	9.9	1.92	9.3	1.71	9.0	1.64	8.7	1.59	8.1	1.46
	5.0	4.1	10.5	1.95	9.9	1.75	9.3	1.61	9.0	1.55	8.7	1.50	8.1	1.37
	7.0	6.0	10.5	1.77	9.9	1.65	9.3	1.51	9.0	1.45	8.7	1.41	8.1	1.29
	9.0	7.9	10.5	1.66	9.9	1.55	9.3	1.43	9.0	1.37	8.7	1.33	8.1	1.21
	11.0	9.8	10.5	1.57	9.9	1.46	9.3	1.34	9.0	1.29	8.7	1.25	8.1	1.15
13.0	11.8	10.5	1.47	9.9	1.37	9.3	1.26	9.0	1.21	8.7	1.18	8.1	1.08	
15.0	13.7	10.5	1.38	9.9	1.29	9.3	1.19	9.0	1.15	8.7	1.11	8.1	1.02	

Abbreviations:

TC: Total capacity (kW)

PI: Power input (compressor + outdoor fan motor) (kW)

Table 2-8.29: VMEX012Q8A-D23V400 heating part load performance

Part load	Outdoor air temp.		Indoor air temp. (°C DB)											
			16.0		18.0		20.0		21.0		22.0		24.0	
	(°C DB)	(°C WB)	TC kW	PI kW	TC kW	PI kW	TC kW	PI kW	TC kW	PI kW	TC kW	PI kW	TC kW	PI kW
100%	-19.8	-20.0	28.7	8.53	28.6	8.88	28.6	9.25	28.4	9.43	28.4	9.60	28.3	9.96
	-18.8	-19.0	29.1	8.64	29.1	8.99	29.0	9.34	29.0	9.53	28.9	9.71	28.9	10.06
	-16.7	-17.0	30.3	8.88	30.1	9.22	30.1	9.56	30.0	9.73	30.0	9.90	30.0	10.24
	-13.7	-15.0	31.6	9.14	31.4	9.47	31.3	9.79	31.3	9.96	31.3	10.12	31.1	10.45
	-11.8	-13.0	32.9	9.40	32.9	9.71	32.7	10.03	32.7	10.18	32.7	10.34	32.6	10.66
	-9.8	-11.0	34.4	9.66	34.3	9.96	34.3	10.26	34.3	10.42	34.1	10.56	34.1	10.85
	-9.5	-10.0	35.3	9.79	35.1	10.09	35.1	10.38	35.0	10.53	35.0	10.67	34.9	10.96
	-8.5	-9.1	36.0	9.90	35.9	10.20	35.9	10.48	35.9	10.62	35.7	10.77	35.7	11.05
	-7.0	-7.6	37.3	10.10	37.3	10.38	37.1	10.65	37.1	10.79	37.1	10.93	37.0	11.21
	-5.0	-5.6	39.3	10.35	39.1	10.61	39.1	10.88	39.0	11.00	39.0	11.13	38.9	11.40
	-3.0	-3.7	41.1	10.59	41.1	9.61	41.0	11.09	41.0	11.21	41.0	11.33	39.3	10.85
	0.0	-0.7	44.4	10.93	44.4	11.16	44.3	11.39	43.6	11.21	42.1	10.74	39.3	9.85
	3.0	2.2	48.0	11.24	47.9	11.45	45.0	10.60	43.6	10.18	42.1	9.78	39.3	8.98
	5.0	4.1	50.4	11.45	47.9	10.76	45.0	9.96	43.6	9.59	42.1	9.21	39.3	8.47
	7.0	6.0	50.7	10.87	47.9	10.11	45.0	9.38	43.6	9.03	42.1	8.67	39.3	7.98
	9.0	7.9	50.7	10.21	47.9	9.51	45.0	8.83	43.6	8.39	42.1	8.17	39.3	7.53
	11.0	9.8	50.7	9.61	47.9	8.97	45.0	8.33	43.6	8.02	42.1	7.71	39.3	7.11
13.0	11.8	50.7	9.03	47.9	8.43	45.0	7.85	43.6	7.55	42.1	7.27	39.3	6.71	
15.0	13.7	50.7	8.52	47.9	7.96	45.0	7.41	43.6	7.14	42.1	6.87	39.3	6.36	
75%	-19.8	-20.0	26.7	10.78	26.7	11.12	26.6	11.38	26.6	11.56	26.6	11.73	26.6	12.07
	-18.8	-19.0	27.3	10.86	27.2	11.21	27.1	11.56	27.1	11.64	27.1	11.82	27.0	12.16
	-16.7	-17.0	28.4	11.12	28.3	11.38	28.2	11.73	28.2	11.90	28.2	11.99	28.1	12.33
	-13.7	-15.0	29.5	11.30	29.4	11.64	29.4	11.90	29.3	12.07	29.3	12.16	29.3	12.51
	-11.8	-13.0	30.9	11.56	30.8	11.82	30.8	12.07	30.7	12.25	30.7	12.42	29.3	11.82
	-9.8	-11.0	32.3	11.82	32.2	12.07	32.2	12.33	32.1	12.42	31.5	12.16	29.3	11.21
	-9.5	-10.0	33.1	11.90	33.0	12.16	32.9	12.42	32.6	12.33	31.5	11.82	29.3	10.86
	-8.5	-9.1	33.8	11.99	33.8	12.25	33.7	12.51	32.6	11.99	31.5	11.56	29.3	10.61
	-7.0	-7.6	35.0	12.16	35.0	12.42	33.7	11.90	32.6	11.47	31.5	11.04	29.3	10.09
	-5.0	-5.6	36.8	12.42	35.8	12.07	33.7	11.21	32.6	10.78	31.5	10.35	29.3	9.57
	-3.0	-3.7	38.0	12.25	35.8	11.38	33.7	10.61	32.6	10.17	31.5	9.83	29.3	7.81
	0.0	-0.7	38.0	11.12	35.8	10.43	33.7	9.65	32.6	9.05	31.5	7.75	29.3	7.12
	3.0	2.2	38.0	10.17	35.8	9.48	33.7	7.66	32.6	7.37	31.5	7.09	29.3	6.53
	5.0	4.1	38.0	9.65	35.8	7.77	33.7	7.23	32.6	6.96	31.5	6.69	29.3	6.17
	7.0	6.0	38.0	7.86	35.8	7.33	33.7	6.82	32.6	6.57	31.5	6.32	29.3	5.84
	9.0	7.9	38.0	7.41	35.8	6.92	33.7	6.45	32.6	6.21	31.5	5.98	29.3	5.33
	11.0	9.8	38.0	6.99	35.8	6.54	33.7	6.10	32.6	5.88	31.5	5.56	29.3	4.87
13.0	11.8	38.0	6.60	35.8	6.17	33.7	5.71	32.6	5.38	31.5	5.05	29.3	4.41	
15.0	13.7	38.0	6.24	35.8	5.84	33.7	5.22	32.6	4.91	31.5	4.60	29.3	4.15	
50%	-19.8	-20.0	25.3	11.82	23.9	11.04	22.4	10.26	21.7	9.83	21.0	9.48	19.5	7.55
	-18.8	-19.0	25.3	11.56	23.9	10.78	22.4	10.00	21.7	9.65	21.0	8.96	19.5	7.38
	-16.7	-17.0	25.3	11.04	23.9	10.26	22.4	9.57	21.7	8.59	21.0	7.66	19.5	7.05
	-13.7	-15.0	25.3	10.43	23.9	9.74	22.4	8.06	21.7	7.57	21.0	7.28	19.5	6.71
	-11.8	-13.0	25.3	9.91	23.9	8.96	22.4	7.47	21.7	7.18	21.0	6.91	19.5	6.37
	-9.8	-11.0	25.3	9.40	23.9	7.60	22.4	7.06	21.7	6.80	21.0	6.54	19.5	6.04
	-9.5	-10.0	25.3	8.26	23.9	7.39	22.4	6.87	21.7	6.62	21.0	6.37	19.5	5.88
	-8.5	-9.1	25.3	7.71	23.9	7.20	22.4	6.70	21.7	6.46	21.0	6.22	19.5	5.69
	-7.0	-7.6	25.3	7.38	23.9	6.90	22.4	6.42	21.7	6.19	21.0	5.96	19.5	5.31
	-5.0	-5.6	25.3	6.96	23.9	6.51	22.4	6.06	21.7	5.84	21.0	5.52	19.5	4.83
	-3.0	-3.7	25.3	6.58	23.9	6.16	22.4	5.69	21.7	5.36	21.0	5.03	19.5	4.39
	0.0	-0.7	25.3	6.03	23.9	5.53	22.4	4.93	21.7	4.63	21.0	4.36	19.5	4.00
	3.0	2.2	25.3	5.36	23.9	4.80	22.4	4.31	21.7	4.14	21.0	3.97	19.5	3.64
	5.0	4.1	25.3	4.88	23.9	4.38	22.4	4.06	21.7	3.89	21.0	3.74	19.5	3.43
	7.0	6.0	25.3	4.43	23.9	4.12	22.4	3.81	21.7	3.67	21.0	3.52	19.5	3.24
	9.0	7.9	25.3	4.16	23.9	3.87	22.4	3.60	21.7	3.45	21.0	3.32	19.5	3.05
	11.0	9.8	25.3	3.92	23.9	3.65	22.4	3.39	21.7	3.26	21.0	3.13	19.5	2.87
13.0	11.8	25.3	3.68	23.9	3.43	22.4	3.18	21.7	3.06	21.0	2.94	19.5	2.71	
15.0	13.7	25.3	3.48	23.9	3.24	22.4	3.01	21.7	2.89	21.0	2.78	19.5	2.55	
25%	-19.8	-20.0	12.6	5.62	11.9	5.25	11.2	4.91	10.8	4.67	10.5	4.54	9.7	3.62
	-18.8	-19.0	12.6	5.49	11.9	5.13	11.2	4.79	10.8	4.58	10.5	4.30	9.7	3.54
	-16.7	-17.0	12.6	5.25	11.9	4.88	11.2	4.58	10.8	4.08	10.5	3.67	9.7	3.38
	-13.7	-15.0	12.6	4.96	11.9	4.64	11.2	3.86	10.8	3.59	10.5	3.49	9.7	3.22
	-11.8	-13.0	12.6	4.71	11.9	4.26	11.2	3.58	10.8	3.41	10.5	3.31	9.7	3.05
	-9.8	-11.0	12.6	4.47	11.9	3.62	11.2	3.38	10.8	3.23	10.5	3.14	9.7	2.89
	-9.5	-10.0	12.6	3.92	11.9	3.52	11.2	3.29	10.8	3.14	10.5	3.05	9.7	2.82
	-8.5	-9.1	12.6	3.66	11.9	3.43	11.2	3.21	10.8	3.07	10.5	2.98	9.7	2.73
	-7.0	-7.6	12.6	3.51	11.9	3.28	11.2	3.07	10.8	2.94	10.5	2.86	9.7	2.54
	-5.0	-5.6	12.6	3.31	11.9	3.10	11.2	2.90	10.8	2.77	10.5	2.65	9.7	2.31
	-3.0	-3.7	12.6	3.13	11.9	2.93	11.2	2.72	10.8	2.55	10.5	2.41	9.7	2.10
	0.0	-0.7	12.6	2.87	11.9	2.63	11.2	2.36	10.8	2.20	10.5	2.09	9.7	1.92
	3.0	2.2	12.6	2.55	11.9	2.28	11.2	2.06	10.8	1.97	10.5	1.90	9.7	1.74
	5.0	4.1	12.6	2.32	11.9	2.08	11.2	1.94	10.8	1.85	10.5	1.79	9.7	1.64
	7.0	6.0	12.6	2.11	11.9	1.96	11.2	1.82	10.8	1.74	10.5	1.69	9.7	1.55
	9.0	7.9	12.6	1.98	11.9	1.84	11.2	1.72	10.8	1.64	10.5	1.59	9.7	1.46
	11.0	9.8	12.6	1.86	11.9	1.74	11.2	1.62	10.8	1.55	10.5	1.50	9.7	1.38
13.0	11.8	12.6	1.75	11.9	1.63	11.2	1.52	10.8	1.45	10.5	1.41	9.7	1.30	
15.0	13.7	12.6	1.65	11.9	1.54	11.2	1.44	10.8	1.37	10.5	1.33	9.7	1.22	

Abbreviations:

TC: Total capacity (kW)

PI: Power input (compressor + outdoor fan motor) (kW)

# VMEX 460V 60Hz

Table 2-8.30: VMEX014Q8A-D26V450 heating part load performance

Part load	Outdoor air temp.		Indoor air temp. (°C DB)											
			16.0		18.0		20.0		21.0		22.0		24.0	
	(°C DB)	(°C WB)	TC kW	PI kW	TC kW	PI kW	TC kW	PI kW	TC kW	PI kW	TC kW	PI kW	TC kW	PI kW
100%	-19.8	-20.0	31.9	9.88	31.7	10.29	31.7	10.71	31.6	10.93	31.6	11.12	31.4	11.55
	-18.8	-19.0	32.4	10.01	32.4	10.42	32.2	10.83	32.2	11.04	32.1	11.25	32.1	11.66
	-16.7	-17.0	33.7	10.29	33.5	10.69	33.5	11.08	33.3	11.28	33.3	11.48	33.3	11.87
	-13.7	-15.0	35.1	10.59	34.9	10.97	34.8	11.35	34.8	11.55	34.8	11.73	34.6	12.11
	-11.8	-13.0	36.5	10.90	36.5	11.25	36.4	11.62	36.4	11.80	36.4	11.99	36.2	12.35
	-9.8	-11.0	38.3	11.20	38.1	11.55	38.1	11.89	38.1	12.07	37.9	12.24	37.9	12.58
	-9.5	-10.0	39.2	11.35	39.1	11.69	39.1	12.03	38.9	12.20	38.9	12.37	38.7	12.70
	-8.5	-9.1	40.0	11.48	39.8	11.82	39.8	12.14	39.8	12.31	39.7	12.48	39.7	12.80
	-7.0	-7.6	41.4	11.70	41.4	12.03	41.3	12.34	41.3	12.51	41.3	12.66	41.1	12.99
	-5.0	-5.6	43.7	12.00	43.5	12.30	43.5	12.61	43.3	12.75	43.3	12.90	43.2	13.21
	-3.0	-3.7	45.7	12.27	45.7	11.14	45.6	12.85	45.6	12.99	45.6	13.13	43.7	12.58
	0.0	-0.7	49.4	12.66	49.4	12.93	49.2	13.20	48.4	12.99	46.8	12.45	43.7	11.42
	3.0	2.2	53.3	13.03	53.2	13.27	50.0	12.28	48.4	11.80	46.8	11.34	43.7	10.40
	5.0	4.1	56.0	13.27	53.2	12.47	50.0	11.55	48.4	11.11	46.8	10.67	43.7	9.81
	7.0	6.0	56.4	12.59	53.2	11.72	50.0	10.87	48.4	10.46	46.8	10.05	43.7	9.25
	9.0	7.9	56.4	11.83	53.2	11.03	50.0	10.24	48.4	9.73	46.8	9.47	43.7	8.72
11.0	9.8	56.4	11.14	53.2	10.39	50.0	9.66	48.4	9.29	46.8	8.94	43.7	8.24	
13.0	11.8	56.4	10.46	53.2	9.77	50.0	9.09	48.4	8.75	46.8	8.43	43.7	7.78	
15.0	13.7	56.4	9.87	53.2	9.22	50.0	8.58	48.4	8.27	46.8	7.96	43.7	7.37	
75%	-19.8	-20.0	29.7	12.52	29.7	12.92	29.6	13.22	29.6	13.42	29.5	13.62	29.5	14.02
	-18.8	-19.0	30.3	12.62	30.2	13.02	30.1	13.42	30.1	13.52	30.1	13.72	30.0	14.12
	-16.7	-17.0	31.5	12.92	31.4	13.22	31.3	13.62	31.3	13.82	31.3	13.92	31.2	14.32
	-13.7	-15.0	32.8	13.12	32.7	13.52	32.7	13.82	32.6	14.02	32.6	14.12	32.5	14.52
	-11.8	-13.0	34.3	13.42	34.2	13.72	34.2	14.02	34.1	14.22	34.1	14.42	32.6	13.72
	-9.8	-11.0	35.9	13.72	35.8	14.02	35.8	14.32	35.7	14.42	35.0	14.12	32.6	13.02
	-9.5	-10.0	36.8	13.82	36.7	14.12	36.6	14.42	36.2	14.32	35.0	13.72	32.6	12.62
	-8.5	-9.1	37.5	13.92	37.5	14.22	37.4	14.52	36.2	13.92	35.0	13.42	32.6	12.32
	-7.0	-7.6	38.9	14.12	38.9	14.42	37.4	13.82	36.2	13.32	35.0	12.82	32.6	11.71
	-5.0	-5.6	40.9	14.42	39.8	14.02	37.4	13.02	36.2	12.52	35.0	12.02	32.6	11.11
	-3.0	-3.7	42.2	14.22	39.8	13.22	37.4	12.32	36.2	11.81	35.0	11.41	32.6	9.07
	0.0	-0.7	42.2	12.92	39.8	12.12	37.4	11.21	36.2	10.51	35.0	9.00	32.6	8.27
	3.0	2.2	42.2	11.81	39.8	11.01	37.4	8.89	36.2	8.56	35.0	8.23	32.6	7.58
	5.0	4.1	42.2	11.21	39.8	9.03	37.4	8.39	36.2	8.08	35.0	7.77	32.6	7.17
	7.0	6.0	42.2	9.13	39.8	8.51	37.4	7.92	36.2	7.63	35.0	7.34	32.6	6.78
	9.0	7.9	42.2	8.60	39.8	8.04	37.4	7.49	36.2	7.21	35.0	6.95	32.6	6.20
11.0	9.8	42.2	8.12	39.8	7.60	37.4	7.08	36.2	6.83	35.0	6.46	32.6	5.65	
13.0	11.8	42.2	7.66	39.8	7.17	37.4	6.63	36.2	6.25	35.0	5.86	32.6	5.12	
15.0	13.7	42.2	7.25	39.8	6.79	37.4	6.07	36.2	5.70	35.0	5.34	32.6	4.82	
50%	-19.8	-20.0	28.1	13.72	26.5	12.82	24.9	11.92	24.1	11.41	23.3	11.01	21.7	8.76
	-18.8	-19.0	28.1	13.42	26.5	12.52	24.9	11.61	24.1	11.21	23.3	10.41	21.7	8.57
	-16.7	-17.0	28.1	12.82	26.5	11.92	24.9	11.11	24.1	9.98	23.3	8.89	21.7	8.18
	-13.7	-15.0	28.1	12.12	26.5	11.31	24.9	9.36	24.1	8.79	23.3	8.45	21.7	7.79
	-11.8	-13.0	28.1	11.51	26.5	10.41	24.9	8.67	24.1	8.34	23.3	8.02	21.7	7.40
	-9.8	-11.0	28.1	10.91	26.5	8.82	24.9	8.20	24.1	7.90	23.3	7.60	21.7	7.02
	-9.5	-10.0	28.1	9.60	26.5	8.58	24.9	7.98	24.1	7.69	23.3	7.40	21.7	6.83
	-8.5	-9.1	28.1	8.96	26.5	8.36	24.9	7.78	24.1	7.50	23.3	7.22	21.7	6.61
	-7.0	-7.6	28.1	8.57	26.5	8.01	24.9	7.46	24.1	7.19	23.3	6.92	21.7	6.17
	-5.0	-5.6	28.1	8.08	26.5	7.56	24.9	7.04	24.1	6.79	23.3	6.41	21.7	5.60
	-3.0	-3.7	28.1	7.64	26.5	7.15	24.9	6.61	24.1	6.23	23.3	5.84	21.7	5.10
	0.0	-0.7	28.1	7.00	26.5	6.43	24.9	5.72	24.1	5.37	23.3	5.06	21.7	4.64
	3.0	2.2	28.1	6.23	26.5	5.57	24.9	5.00	24.1	4.81	23.3	4.61	21.7	4.23
	5.0	4.1	28.1	5.66	26.5	5.08	24.9	4.71	24.1	4.52	23.3	4.34	21.7	3.99
	7.0	6.0	28.1	5.14	26.5	4.78	24.9	4.43	24.1	4.26	23.3	4.09	21.7	3.76
	9.0	7.9	28.1	4.83	26.5	4.50	24.9	4.18	24.1	4.01	23.3	3.86	21.7	3.54
11.0	9.8	28.1	4.55	26.5	4.24	24.9	3.94	24.1	3.79	23.3	3.64	21.7	3.34	
13.0	11.8	28.1	4.28	26.5	3.99	24.9	3.70	24.1	3.56	23.3	3.42	21.7	3.15	
15.0	13.7	28.1	4.04	26.5	3.76	24.9	3.50	24.1	3.36	23.3	3.23	21.7	2.96	
25%	-19.8	-20.0	14.0	6.65	13.2	6.18	12.4	5.75	12.0	5.48	11.6	5.30	10.8	4.18
	-18.8	-19.0	14.0	6.50	13.2	6.04	12.4	5.60	12.0	5.39	11.6	5.01	10.8	4.09
	-16.7	-17.0	14.0	6.21	13.2	5.75	12.4	5.36	12.0	4.80	11.6	4.28	10.8	3.91
	-13.7	-15.0	14.0	5.87	13.2	5.45	12.4	4.51	12.0	4.22	11.6	4.06	10.8	3.72
	-11.8	-13.0	14.0	5.58	13.2	5.02	12.4	4.18	12.0	4.01	11.6	3.86	10.8	3.53
	-9.8	-11.0	14.0	5.29	13.2	4.25	12.4	3.95	12.0	3.80	11.6	3.66	10.8	3.35
	-9.5	-10.0	14.0	4.65	13.2	4.14	12.4	3.85	12.0	3.70	11.6	3.56	10.8	3.26
	-8.5	-9.1	14.0	4.34	13.2	4.03	12.4	3.75	12.0	3.60	11.6	3.47	10.8	3.16
	-7.0	-7.6	14.0	4.15	13.2	3.86	12.4	3.60	12.0	3.46	11.6	3.33	10.8	2.95
	-5.0	-5.6	14.0	3.91	13.2	3.64	12.4	3.39	12.0	3.26	11.6	3.08	10.8	2.67
	-3.0	-3.7	14.0	3.70	13.2	3.45	12.4	3.19	12.0	2.99	11.6	2.81	10.8	2.44
	0.0	-0.7	14.0	3.39	13.2	3.10	12.4	2.76	12.0	2.58	11.6	2.43	10.8	2.22
	3.0	2.2	14.0	3.02	13.2	2.69	12.4	2.41	12.0	2.31	11.6	2.22	10.8	2.02
	5.0	4.1	14.0	2.74	13.2	2.45	12.4	2.27	12.0	2.17	11.6	2.09	10.8	1.91
	7.0	6.0	14.0	2.49	13.2	2.30	12.4	2.14	12.0	2.05	11.6	1.97	10.8	1.80
	9.0	7.9	14.0	2.34	13.2	2.17	12.4	2.01	12.0	1.93	11.6	1.86	10.8	1.69
11.0	9.8	14.0	2.20	13.2	2.04	12.4	1.90	12.0	1.82	11.6	1.75	10.8	1.60	
13.0	11.8	14.0	2.07	13.2	1.92	12.4	1.78	12.0	1.71	11.6	1.64	10.8	1.50	
15.0	13.7	14.0	1.96	13.2	1.81	12.4	1.69	12.0	1.61	11.6	1.55	10.8	1.41	

Abbreviations:

TC: Total capacity (kW)

PI: Power input (compressor + outdoor fan motor) (kW)

Table 2-8.31: VMEX016Q8A-D29V500 heating part load performance

Part load	Outdoor air temp.		Indoor air temp. (°C DB)											
			16.0		18.0		20.0		21.0		22.0		24.0	
	(°C DB)	(°C WB)	TC kW	PI kW	TC kW	PI kW	TC kW	PI kW	TC kW	PI kW	TC kW	PI kW	TC kW	PI kW
100%	-19.8	-20.0	35.7	11.98	35.6	12.48	35.6	12.99	35.4	13.25	35.4	13.49	35.2	14.00
	-18.8	-19.0	36.3	12.14	36.3	12.63	36.1	13.13	36.1	13.39	35.9	13.64	35.9	14.14
	-16.7	-17.0	37.7	12.48	37.5	12.96	37.5	13.44	37.3	13.68	37.3	13.92	37.3	14.40
	-13.7	-15.0	39.3	12.84	39.1	13.30	38.9	13.76	38.9	14.00	38.9	14.22	38.8	14.69
	-11.8	-13.0	40.9	13.21	40.9	13.64	40.7	14.09	40.7	14.31	40.7	14.53	40.5	14.98
	-9.8	-11.0	42.8	13.57	42.7	14.00	42.7	14.41	42.7	14.64	42.5	14.84	42.5	15.25
	-9.5	-10.0	43.9	13.76	43.7	14.17	43.7	14.58	43.6	14.79	43.6	14.99	43.4	15.40
	-8.5	-9.1	44.8	13.92	44.6	14.33	44.6	14.72	44.6	14.93	44.4	15.13	44.4	15.52
	-7.0	-7.6	46.4	14.19	46.4	14.58	46.2	14.96	46.2	15.16	46.2	15.35	46.0	15.75
	-5.0	-5.6	48.9	14.55	48.7	14.91	48.7	15.28	48.5	15.46	48.5	15.64	48.4	16.02
	-3.0	-3.7	51.2	14.87	51.2	15.51	51.0	15.58	51.0	15.75	51.0	15.92	48.9	15.25
	0.0	-0.7	55.3	15.35	55.3	15.68	55.1	16.00	54.2	15.75	52.4	15.10	48.9	13.85
	3.0	2.2	59.7	15.80	59.6	16.09	56.0	14.89	54.2	14.31	52.4	13.75	48.9	12.61
	5.0	4.1	62.8	16.09	59.6	15.11	56.0	14.00	54.2	13.47	52.4	12.94	48.9	11.90
	7.0	6.0	63.1	15.27	59.6	14.21	56.0	13.18	54.2	12.68	52.4	12.19	48.9	11.21
	9.0	7.9	63.1	14.34	59.6	13.37	56.0	12.41	54.2	11.79	52.4	11.49	48.9	10.58
	11.0	9.8	63.1	13.51	59.6	12.60	56.0	11.71	54.2	11.26	52.4	10.84	48.9	10.00
13.0	11.8	63.1	12.68	59.6	11.84	56.0	11.02	54.2	10.61	52.4	10.22	48.9	9.43	
15.0	13.7	63.1	11.96	59.6	11.18	56.0	10.41	54.2	10.03	52.4	9.65	48.9	8.93	
75%	-19.8	-20.0	33.3	14.07	33.3	14.52	33.2	14.86	33.2	15.08	33.0	15.31	33.0	15.76
	-18.8	-19.0	33.9	14.18	33.8	14.63	33.7	15.08	33.7	15.19	33.7	15.42	33.6	15.87
	-16.7	-17.0	35.3	14.52	35.2	14.86	35.1	15.31	35.1	15.53	35.1	15.64	34.9	16.10
	-13.7	-15.0	36.7	14.74	36.6	15.19	36.6	15.53	36.5	15.76	36.5	15.87	36.4	16.32
	-11.8	-13.0	38.4	15.08	38.3	15.42	38.3	15.76	38.2	15.98	38.2	16.21	36.5	15.42
	-9.8	-11.0	40.2	15.42	40.1	15.76	40.1	16.10	40.0	16.21	39.2	15.87	36.5	14.63
	-9.5	-10.0	41.2	15.53	41.1	15.87	41.0	16.21	40.5	16.10	39.2	15.42	36.5	14.18
	-8.5	-9.1	42.0	15.64	42.0	15.98	41.9	16.32	40.5	15.64	39.2	15.08	36.5	13.84
	-7.0	-7.6	43.6	15.87	43.6	16.21	41.9	15.53	40.5	14.97	39.2	14.40	36.5	13.16
	-5.0	-5.6	45.8	16.21	44.6	15.76	41.9	14.63	40.5	14.07	39.2	13.50	36.5	12.49
	-3.0	-3.7	47.3	15.98	44.6	14.86	41.9	13.84	40.5	13.28	39.2	12.83	36.5	10.19
	0.0	-0.7	47.3	14.52	44.6	13.61	41.9	12.60	40.5	11.81	39.2	10.11	36.5	9.30
	3.0	2.2	47.3	13.28	44.6	12.37	41.9	10.00	40.5	9.62	39.2	9.25	36.5	8.52
	5.0	4.1	47.3	12.60	44.6	10.14	41.9	9.43	40.5	9.08	39.2	8.73	36.5	8.06
	7.0	6.0	47.3	10.25	44.6	9.57	41.9	8.90	40.5	8.57	39.2	8.25	36.5	7.62
	9.0	7.9	47.3	9.67	44.6	9.04	41.9	8.42	40.5	8.10	39.2	7.81	36.5	6.96
	11.0	9.8	47.3	9.13	44.6	8.54	41.9	7.95	40.5	7.67	39.2	7.26	36.5	6.35
13.0	11.8	47.3	8.61	44.6	8.06	41.9	7.45	40.5	7.02	39.2	6.59	36.5	5.76	
15.0	13.7	47.3	8.15	44.6	7.63	41.9	6.82	40.5	6.41	39.2	6.00	36.5	5.42	
50%	-19.8	-20.0	31.5	15.42	29.7	14.40	27.9	13.39	27.0	12.83	26.1	12.37	24.3	9.85
	-18.8	-19.0	31.5	15.08	29.7	14.07	27.9	13.05	27.0	12.60	26.1	11.70	24.3	9.63
	-16.7	-17.0	31.5	14.40	29.7	13.39	27.9	12.49	27.0	11.21	26.1	10.00	24.3	9.19
	-13.7	-15.0	31.5	13.61	29.7	12.71	27.9	10.51	27.0	9.88	26.1	9.50	24.3	8.75
	-11.8	-13.0	31.5	12.94	29.7	11.70	27.9	9.75	27.0	9.38	26.1	9.01	24.3	8.32
	-9.8	-11.0	31.5	12.26	29.7	9.92	27.9	9.22	27.0	8.88	26.1	8.54	24.3	7.89
	-9.5	-10.0	31.5	10.78	29.7	9.65	27.9	8.97	27.0	8.64	26.1	8.32	24.3	7.67
	-8.5	-9.1	31.5	10.06	29.7	9.40	27.9	8.74	27.0	8.43	26.1	8.11	24.3	7.42
	-7.0	-7.6	31.5	9.63	29.7	9.00	27.9	8.38	27.0	8.08	26.1	7.77	24.3	6.93
	-5.0	-5.6	31.5	9.08	29.7	8.50	27.9	7.91	27.0	7.63	26.1	7.20	24.3	6.30
	-3.0	-3.7	31.5	8.59	29.7	8.03	27.9	7.42	27.0	7.00	26.1	6.57	24.3	5.73
	0.0	-0.7	31.5	7.86	29.7	7.22	27.9	6.43	27.0	6.04	26.1	5.69	24.3	5.21
	3.0	2.2	31.5	7.00	29.7	6.26	27.9	5.62	27.0	5.41	26.1	5.18	24.3	4.75
	5.0	4.1	31.5	6.36	29.7	5.71	27.9	5.29	27.0	5.08	26.1	4.88	24.3	4.48
	7.0	6.0	31.5	5.78	29.7	5.37	27.9	4.98	27.0	4.79	26.1	4.59	24.3	4.22
	9.0	7.9	31.5	5.43	29.7	5.06	27.9	4.70	27.0	4.50	26.1	4.33	24.3	3.97
	11.0	9.8	31.5	5.11	29.7	4.76	27.9	4.43	27.0	4.26	26.1	4.09	24.3	3.75
13.0	11.8	31.5	4.81	29.7	4.48	27.9	4.15	27.0	4.00	26.1	3.84	24.3	3.53	
15.0	13.7	31.5	4.54	29.7	4.22	27.9	3.93	27.0	3.77	26.1	3.62	24.3	3.33	
25%	-19.8	-20.0	15.7	7.48	14.8	6.98	13.9	6.46	13.5	6.23	13.0	5.98	12.1	4.86
	-18.8	-19.0	15.7	7.31	14.8	6.82	13.9	6.30	13.5	6.12	13.0	5.65	12.1	4.75
	-16.7	-17.0	15.7	6.98	14.8	6.49	13.9	6.03	13.5	5.44	13.0	4.83	12.1	4.53
	-13.7	-15.0	15.7	6.60	14.8	6.16	13.9	5.07	13.5	4.80	13.0	4.59	12.1	4.32
	-11.8	-13.0	15.7	6.28	14.8	5.67	13.9	4.70	13.5	4.55	13.0	4.35	12.1	4.11
	-9.8	-11.0	15.7	5.95	14.8	4.81	13.9	4.45	13.5	4.31	13.0	4.13	12.1	3.89
	-9.5	-10.0	15.7	5.23	14.8	4.68	13.9	4.33	13.5	4.20	13.0	4.02	12.1	3.78
	-8.5	-9.1	15.7	4.88	14.8	4.56	13.9	4.22	13.5	4.09	13.0	3.92	12.1	3.66
	-7.0	-7.6	15.7	4.67	14.8	4.36	13.9	4.04	13.5	3.92	13.0	3.76	12.1	3.42
	-5.0	-5.6	15.7	4.40	14.8	4.12	13.9	3.82	13.5	3.71	13.0	3.48	12.1	3.11
	-3.0	-3.7	15.7	4.17	14.8	3.89	13.9	3.58	13.5	3.40	13.0	3.18	12.1	2.83
	0.0	-0.7	15.7	3.81	14.8	3.50	13.9	3.10	13.5	2.93	13.0	2.75	12.1	2.57
	3.0	2.2	15.7	3.39	14.8	3.04	13.9	2.71	13.5	2.63	13.0	2.50	12.1	2.34
	5.0	4.1	15.7	3.08	14.8	2.77	13.9	2.55	13.5	2.47	13.0	2.36	12.1	2.21
	7.0	6.0	15.7	2.80	14.8	2.60	13.9	2.40	13.5	2.33	13.0	2.22	12.1	2.08
	9.0	7.9	15.7	2.63	14.8	2.45	13.9	2.27	13.5	2.19	13.0	2.09	12.1	1.96
	11.0	9.8	15.7	2.48	14.8	2.31	13.9	2.14	13.5	2.07	13.0	1.98	12.1	1.85
13.0	11.8	15.7	2.33	14.8	2.17	13.9	2.00	13.5	1.94	13.0	1.86	12.1	1.74	
15.0	13.7	15.7	2.20	14.8	2.05	13.9	1.90	13.5	1.83	13.0	1.75	12.1	1.64	

Abbreviations:

TC: Total capacity (kW)

PI: Power input (compressor + outdoor fan motor) (kW)

# VMEX 460V 60Hz

Table 2-8.32: VMEX018Q8A-D33V560 heating part load performance

Part load	Outdoor air temp.		Indoor air temp. (°C DB)											
			16.0		18.0		20.0		21.0		22.0		24.0	
	(°C DB)	(°C WB)	TC kW	PI kW	TC kW	PI kW	TC kW	PI kW	TC kW	PI kW	TC kW	PI kW	TC kW	PI kW
100%	-19.8	-20.0	40.2	13.90	40.0	14.48	40.0	15.07	39.8	15.37	39.8	15.65	39.6	16.24
	-18.8	-19.0	40.8	14.08	40.8	14.65	40.6	15.23	40.6	15.53	40.4	15.83	40.4	16.40
	-16.7	-17.0	42.4	14.48	42.2	15.03	42.2	15.59	42.0	15.87	42.0	16.14	42.0	16.70
	-13.7	-15.0	44.2	14.89	44.0	15.43	43.8	15.97	43.8	16.24	43.8	16.50	43.6	17.04
	-11.8	-13.0	46.0	15.33	46.0	15.83	45.8	16.34	45.8	16.60	45.8	16.86	45.6	17.38
	-9.8	-11.0	48.2	15.75	48.0	16.24	48.0	16.72	48.0	16.98	47.8	17.22	47.8	17.69
	-9.5	-10.0	49.4	15.97	49.2	16.44	49.2	16.92	49.0	17.16	49.0	17.40	48.8	17.87
	-8.5	-9.1	50.4	16.14	50.2	16.62	50.2	17.08	50.2	17.32	50.0	17.55	50.0	18.01
	-7.0	-7.6	52.2	16.46	52.2	16.92	52.0	17.36	52.0	17.59	52.0	17.81	51.8	18.27
	-5.0	-5.6	55.0	16.88	54.8	17.30	54.8	17.73	54.6	17.93	54.6	18.15	54.4	18.59
	-3.0	-3.7	57.6	17.26	57.6	15.67	57.4	18.07	57.4	18.27	57.4	18.47	55.0	17.69
	0.0	-0.7	62.2	17.81	62.2	18.19	62.0	18.57	61.0	18.27	59.0	17.51	55.0	16.06
	3.0	2.2	67.2	18.33	67.0	18.67	63.0	17.28	61.0	16.60	59.0	15.95	55.0	14.63
	5.0	4.1	70.6	18.67	67.0	17.53	63.0	16.24	61.0	15.63	59.0	15.01	55.0	13.80
	7.0	6.0	71.0	17.71	67.0	16.48	63.0	15.29	61.0	14.71	59.0	14.14	55.0	13.01
9.0	7.9	71.0	16.64	67.0	15.51	63.0	14.40	61.0	13.68	59.0	13.32	55.0	12.27	
11.0	9.8	71.0	15.67	67.0	14.61	63.0	13.58	61.0	13.07	59.0	12.57	55.0	11.60	
13.0	11.8	71.0	14.71	67.0	13.74	63.0	12.79	61.0	12.31	59.0	11.85	55.0	10.94	
15.0	13.7	71.0	13.88	67.0	12.97	63.0	12.07	61.0	11.64	59.0	11.20	55.0	10.37	
75%	-19.8	-20.0	37.4	15.88	37.4	16.39	37.3	16.78	37.3	17.03	37.2	17.29	37.2	17.80
	-18.8	-19.0	38.2	16.01	38.1	16.52	37.9	17.03	37.9	17.16	37.9	17.41	37.8	17.92
	-16.7	-17.0	39.7	16.39	39.6	16.78	39.4	17.29	39.4	17.54	39.4	17.67	39.3	18.18
	-13.7	-15.0	41.3	16.65	41.2	17.16	41.2	17.54	41.1	17.80	41.1	17.92	41.0	18.43
	-11.8	-13.0	43.2	17.03	43.1	17.41	43.1	17.80	43.0	18.05	43.0	18.30	41.1	17.41
	-9.8	-11.0	45.2	17.41	45.1	17.80	45.1	18.18	45.0	18.30	44.1	17.92	41.1	16.52
	-9.5	-10.0	46.4	17.54	46.2	17.92	46.1	18.30	45.6	18.18	44.1	17.41	41.1	16.01
	-8.5	-9.1	47.3	17.67	47.3	18.05	47.1	18.43	45.6	17.67	44.1	17.03	41.1	15.63
	-7.0	-7.6	49.0	17.92	49.0	18.30	47.1	17.54	45.6	16.90	44.1	16.27	41.1	14.87
	-5.0	-5.6	51.5	18.30	50.1	17.80	47.1	16.52	45.6	15.88	44.1	15.25	41.1	14.10
	-3.0	-3.7	53.2	18.05	50.1	16.78	47.1	15.63	45.6	14.99	44.1	14.48	41.1	11.50
	0.0	-0.7	53.2	16.39	50.1	15.38	47.1	14.23	45.6	13.34	44.1	11.42	41.1	10.50
	3.0	2.2	53.2	14.99	50.1	13.97	47.1	11.29	45.6	10.87	44.1	10.45	41.1	9.62
	5.0	4.1	53.2	14.23	50.1	11.45	47.1	10.65	45.6	10.26	44.1	9.86	41.1	9.10
	7.0	6.0	53.2	11.58	50.1	10.80	47.1	10.05	45.6	9.68	44.1	9.31	41.1	8.60
9.0	7.9	53.2	10.92	50.1	10.21	47.1	9.51	45.6	9.15	44.1	8.82	41.1	7.86	
11.0	9.8	53.2	10.31	50.1	9.65	47.1	8.98	45.6	8.66	44.1	8.19	41.1	7.17	
13.0	11.8	53.2	9.72	50.1	9.10	47.1	8.41	45.6	7.93	44.1	7.44	41.1	6.50	
15.0	13.7	53.2	9.20	50.1	8.61	47.1	7.70	45.6	7.24	44.1	6.78	41.1	6.12	
50%	-19.8	-20.0	35.4	17.41	33.4	16.27	31.4	15.12	30.4	14.48	29.4	13.97	27.3	11.12
	-18.8	-19.0	35.4	17.03	33.4	15.88	31.4	14.74	30.4	14.23	29.4	13.21	27.3	10.88
	-16.7	-17.0	35.4	16.27	33.4	15.12	31.4	14.10	30.4	12.66	29.4	11.29	27.3	10.38
	-13.7	-15.0	35.4	15.38	33.4	14.36	31.4	11.87	30.4	11.16	29.4	10.73	27.3	9.89
	-11.8	-13.0	35.4	14.61	33.4	13.21	31.4	11.01	30.4	10.59	29.4	10.18	27.3	9.39
	-9.8	-11.0	35.4	13.85	33.4	11.20	31.4	10.41	30.4	10.03	29.4	9.65	27.3	8.91
	-9.5	-10.0	35.4	12.18	33.4	10.89	31.4	10.13	30.4	9.76	29.4	9.39	27.3	8.66
	-8.5	-9.1	35.4	11.36	33.4	10.61	31.4	9.87	30.4	9.52	29.4	9.16	27.3	8.38
	-7.0	-7.6	35.4	10.88	33.4	10.17	31.4	9.47	30.4	9.12	29.4	8.78	27.3	7.82
	-5.0	-5.6	35.4	10.26	33.4	9.59	31.4	8.93	30.4	8.61	29.4	8.13	27.3	7.11
	-3.0	-3.7	35.4	9.70	33.4	9.07	31.4	8.38	30.4	7.90	29.4	7.42	27.3	6.47
	0.0	-0.7	35.4	8.88	33.4	8.16	31.4	7.26	30.4	6.82	29.4	6.42	27.3	5.89
	3.0	2.2	35.4	7.90	33.4	7.07	31.4	6.35	30.4	6.11	29.4	5.85	27.3	5.37
	5.0	4.1	35.4	7.19	33.4	6.45	31.4	5.98	30.4	5.74	29.4	5.51	27.3	5.06
	7.0	6.0	35.4	6.53	33.4	6.07	31.4	5.62	30.4	5.40	29.4	5.19	27.3	4.77
9.0	7.9	35.4	6.13	33.4	5.71	31.4	5.30	30.4	5.09	29.4	4.90	27.3	4.49	
11.0	9.8	35.4	5.77	33.4	5.38	31.4	5.00	30.4	4.81	29.4	4.62	27.3	4.23	
13.0	11.8	35.4	5.43	33.4	5.06	31.4	4.69	30.4	4.51	29.4	4.34	27.3	3.99	
15.0	13.7	35.4	5.12	33.4	4.77	31.4	4.44	30.4	4.26	29.4	4.09	27.3	3.76	
25%	-19.8	-20.0	17.6	8.42	16.6	7.87	15.7	7.39	15.2	7.11	14.7	6.89	13.6	5.49
	-18.8	-19.0	17.6	8.24	16.6	7.68	15.7	7.20	15.2	6.99	14.7	6.52	13.6	5.37
	-16.7	-17.0	17.6	7.87	16.6	7.31	15.7	6.89	15.2	6.22	14.7	5.57	13.6	5.12
	-13.7	-15.0	17.6	7.44	16.6	6.94	15.7	5.80	15.2	5.48	14.7	5.29	13.6	4.88
	-11.8	-13.0	17.6	7.07	16.6	6.39	15.7	5.38	15.2	5.20	14.7	5.02	13.6	4.64
	-9.8	-11.0	17.6	6.70	16.6	5.42	15.7	5.09	15.2	4.92	14.7	4.76	13.6	4.40
	-9.5	-10.0	17.6	5.89	16.6	5.27	15.7	4.95	15.2	4.79	14.7	4.63	13.6	4.28
	-8.5	-9.1	17.6	5.50	16.6	5.13	15.7	4.82	15.2	4.67	14.7	4.52	13.6	4.14
	-7.0	-7.6	17.6	5.26	16.6	4.92	15.7	4.63	15.2	4.48	14.7	4.33	13.6	3.86
	-5.0	-5.6	17.6	4.96	16.6	4.64	15.7	4.36	15.2	4.23	14.7	4.01	13.6	3.51
	-3.0	-3.7	17.6	4.69	16.6	4.39	15.7	4.10	15.2	3.88	14.7	3.66	13.6	3.19
	0.0	-0.7	17.6	4.30	16.6	3.95	15.7	3.55	15.2	3.35	14.7	3.17	13.6	2.91
	3.0	2.2	17.6	3.82	16.6	3.42	15.7	3.10	15.2	3.00	14.7	2.89	13.6	2.65
	5.0	4.1	17.6	3.48	16.6	3.12	15.7	2.92	15.2	2.82	14.7	2.72	13.6	2.50
	7.0	6.0	17.6	3.16	16.6	2.94	15.7	2.75	15.2	2.65	14.7	2.56	13.6	2.35
9.0	7.9	17.6	2.97	16.6	2.76	15.7	2.59	15.2	2.50	14.7	2.42	13.6	2.22	
11.0	9.8	17.6	2.79	16.6	2.60	15.7	2.44	15.2	2.36	14.7	2.28	13.6	2.09	
13.0	11.8	17.6	2.63	16.6	2.45	15.7	2.29	15.2	2.21	14.7	2.14	13.6	1.97	
15.0	13.7	17.6	2.48	16.6	2.31	15.7	2.17	15.2	2.09	14.7	2.02	13.6	1.86	

Abbreviations:

TC: Total capacity (kW)

PI: Power input (compressor + outdoor fan motor) (kW)

Table 2-8.33: VMEX020Q8A-D36V615 heating part load performance

Part load	Outdoor air temp.		Indoor air temp. (°C DB)											
			16.0		18.0		20.0		21.0		22.0		24.0	
	(°C DB)	(°C WB)	TC kW	PI kW	TC kW	PI kW	TC kW	PI kW	TC kW	PI kW	TC kW	PI kW	TC kW	PI kW
100%	-19.8	-20.0	44.0	15.56	43.8	16.21	43.8	16.88	43.6	17.21	43.6	17.52	43.4	18.19
	-18.8	-19.0	44.7	15.76	44.7	16.41	44.5	17.05	44.5	17.39	44.2	17.72	44.2	18.36
	-16.7	-17.0	46.4	16.21	46.2	16.83	46.2	17.45	46.0	17.77	46.0	18.08	46.0	18.70
	-13.7	-15.0	48.4	16.67	48.2	17.28	48.0	17.88	48.0	18.19	48.0	18.48	47.8	19.08
	-11.8	-13.0	50.4	17.16	50.4	17.72	50.2	18.30	50.2	18.59	50.2	18.88	49.9	19.46
	-9.8	-11.0	52.8	17.63	52.6	18.19	52.6	18.72	52.6	19.01	52.4	19.28	52.4	19.81
	-9.5	-10.0	54.1	17.88	53.9	18.41	53.9	18.94	53.7	19.21	53.7	19.48	53.4	20.01
	-8.5	-9.1	55.2	18.08	55.0	18.61	55.0	19.12	55.0	19.39	54.8	19.66	54.8	20.17
	-7.0	-7.6	57.2	18.43	57.2	18.94	57.0	19.43	57.0	19.70	57.0	19.94	56.7	20.45
	-5.0	-5.6	60.2	18.90	60.0	19.37	60.0	19.85	59.8	20.08	59.8	20.32	59.6	20.81
	-3.0	-3.7	63.1	19.32	63.1	17.54	62.9	20.23	62.9	20.45	62.9	20.68	60.2	19.81
	0.0	-0.7	68.1	19.94	68.1	20.37	67.9	20.79	66.8	20.45	64.6	19.61	60.2	17.99
	3.0	2.2	73.6	20.52	73.4	20.90	69.0	19.34	66.8	18.59	64.6	17.85	60.2	16.39
	5.0	4.1	77.3	20.90	73.4	19.63	69.0	18.19	66.8	17.50	64.6	16.81	60.2	15.45
	7.0	6.0	77.8	19.83	73.4	18.45	69.0	17.12	66.8	16.47	64.6	15.83	60.2	14.56
	9.0	7.9	77.8	18.63	73.4	17.36	69.0	16.12	66.8	15.32	64.6	14.92	60.2	13.74
11.0	9.8	77.8	17.54	73.4	16.36	69.0	15.21	66.8	14.63	64.6	14.07	60.2	12.98	
13.0	11.8	77.8	16.47	73.4	15.39	69.0	14.32	66.8	13.79	64.6	13.27	60.2	12.25	
15.0	13.7	77.8	15.54	73.4	14.52	69.0	13.52	66.8	13.03	64.6	12.54	60.2	11.61	
75%	-19.8	-20.0	41.0	17.75	41.0	18.32	40.8	18.75	40.8	19.03	40.7	19.32	40.7	19.89
	-18.8	-19.0	41.8	17.90	41.7	18.47	41.5	19.03	41.5	19.18	41.5	19.46	41.4	20.03
	-16.7	-17.0	43.5	18.32	43.3	18.75	43.2	19.32	43.2	19.60	43.2	19.75	43.1	20.32
	-13.7	-15.0	45.3	18.61	45.1	19.18	45.1	19.60	45.0	19.89	45.0	20.03	44.9	20.60
	-11.8	-13.0	47.3	19.03	47.2	19.46	47.2	19.89	47.1	20.17	47.1	20.46	45.0	19.46
	-9.8	-11.0	49.5	19.46	49.4	19.89	49.4	20.32	49.3	20.46	48.3	20.03	45.0	18.47
	-9.5	-10.0	50.8	19.60	50.6	20.03	50.5	20.46	50.0	20.32	48.3	19.46	45.0	17.90
	-8.5	-9.1	51.8	19.75	51.8	20.17	51.6	20.60	50.0	19.75	48.3	19.03	45.0	17.47
	-7.0	-7.6	53.7	20.03	53.7	20.46	51.6	19.60	50.0	18.89	48.3	18.18	45.0	16.62
	-5.0	-5.6	56.4	20.46	54.9	19.89	51.6	18.47	50.0	17.75	48.3	17.04	45.0	15.76
	-3.0	-3.7	58.2	20.17	54.9	18.75	51.6	17.47	50.0	16.76	48.3	16.19	45.0	12.86
	0.0	-0.7	58.2	18.32	54.9	17.18	51.6	15.90	50.0	14.91	48.3	12.76	45.0	11.73
	3.0	2.2	58.2	16.76	54.9	15.62	51.6	12.62	50.0	12.15	48.3	11.68	45.0	10.75
	5.0	4.1	58.2	15.90	54.9	12.80	51.6	11.90	50.0	11.46	48.3	11.02	45.0	10.17
	7.0	6.0	58.2	12.94	54.9	12.08	51.6	11.24	50.0	10.82	48.3	10.41	45.0	9.61
	9.0	7.9	58.2	12.20	54.9	11.41	51.6	10.62	50.0	10.22	48.3	9.85	45.0	8.79
11.0	9.8	58.2	11.52	54.9	10.78	51.6	10.04	50.0	9.68	48.3	9.16	45.0	8.02	
13.0	11.8	58.2	10.87	54.9	10.17	51.6	9.40	50.0	8.86	48.3	8.32	45.0	7.26	
15.0	13.7	58.2	10.28	54.9	9.63	51.6	8.60	50.0	8.09	48.3	7.58	45.0	6.84	
50%	-19.8	-20.0	38.8	19.46	36.6	18.18	34.4	16.90	33.3	16.19	32.2	15.62	29.9	12.43
	-18.8	-19.0	38.8	19.03	36.6	17.75	34.4	16.47	33.3	15.90	32.2	14.77	29.9	12.16
	-16.7	-17.0	38.8	18.18	36.6	16.90	34.4	15.76	33.3	14.15	32.2	12.62	29.9	11.61
	-13.7	-15.0	38.8	17.18	36.6	16.05	34.4	13.27	33.3	12.47	32.2	11.99	29.9	11.05
	-11.8	-13.0	38.8	16.33	36.6	14.77	34.4	12.30	33.3	11.83	32.2	11.38	29.9	10.50
	-9.8	-11.0	38.8	15.48	36.6	12.52	34.4	11.63	33.3	11.21	32.2	10.78	29.9	9.95
	-9.5	-10.0	38.8	13.61	36.6	12.17	34.4	11.32	33.3	10.91	32.2	10.50	29.9	9.68
	-8.5	-9.1	38.8	12.70	36.6	11.86	34.4	11.04	33.3	10.64	32.2	10.24	29.9	9.37
	-7.0	-7.6	38.8	12.16	36.6	11.36	34.4	10.58	33.3	10.20	32.2	9.81	29.9	8.74
	-5.0	-5.6	38.8	11.46	36.6	10.72	34.4	9.98	33.3	9.63	32.2	9.09	29.9	7.95
	-3.0	-3.7	38.8	10.84	36.6	10.14	34.4	9.37	33.3	8.83	32.2	8.29	29.9	7.24
	0.0	-0.7	38.8	9.93	36.6	9.11	34.4	8.12	33.3	7.62	32.2	7.18	29.9	6.58
	3.0	2.2	38.8	8.83	36.6	7.91	34.4	7.09	33.3	6.82	32.2	6.54	29.9	6.00
	5.0	4.1	38.8	8.03	36.6	7.21	34.4	6.68	33.3	6.41	32.2	6.15	29.9	5.66
	7.0	6.0	38.8	7.29	36.6	6.78	34.4	6.28	33.3	6.04	32.2	5.80	29.9	5.33
	9.0	7.9	38.8	6.85	36.6	6.38	34.4	5.93	33.3	5.68	32.2	5.47	29.9	5.02
11.0	9.8	38.8	6.45	36.6	6.01	34.4	5.59	33.3	5.37	32.2	5.16	29.9	4.73	
13.0	11.8	38.8	6.07	36.6	5.66	34.4	5.24	33.3	5.04	32.2	4.85	29.9	4.46	
15.0	13.7	38.8	5.73	36.6	5.33	34.4	4.96	33.3	4.76	32.2	4.57	29.9	4.20	
25%	-19.8	-20.0	19.3	9.42	18.2	8.84	17.2	8.30	16.6	7.93	16.1	7.65	14.9	6.07
	-18.8	-19.0	19.3	9.21	18.2	8.63	17.2	8.09	16.6	7.78	16.1	7.23	14.9	5.94
	-16.7	-17.0	19.3	8.80	18.2	8.21	17.2	7.74	16.6	6.93	16.1	6.18	14.9	5.67
	-13.7	-15.0	19.3	8.31	18.2	7.80	17.2	6.52	16.6	6.10	16.1	5.87	14.9	5.40
	-11.8	-13.0	19.3	7.90	18.2	7.18	17.2	6.04	16.6	5.79	16.1	5.57	14.9	5.13
	-9.8	-11.0	19.3	7.49	18.2	6.09	17.2	5.71	16.6	5.49	16.1	5.28	14.9	4.86
	-9.5	-10.0	19.3	6.59	18.2	5.92	17.2	5.56	16.6	5.34	16.1	5.14	14.9	4.73
	-8.5	-9.1	19.3	6.15	18.2	5.76	17.2	5.42	16.6	5.21	16.1	5.01	14.9	4.58
	-7.0	-7.6	19.3	5.89	18.2	5.52	17.2	5.19	16.6	4.99	16.1	4.80	14.9	4.27
	-5.0	-5.6	19.3	5.55	18.2	5.21	17.2	4.90	16.6	4.71	16.1	4.45	14.9	3.88
	-3.0	-3.7	19.3	5.25	18.2	4.93	17.2	4.60	16.6	4.32	16.1	4.06	14.9	3.54
	0.0	-0.7	19.3	4.81	18.2	4.43	17.2	3.99	16.6	3.73	16.1	3.52	14.9	3.21
	3.0	2.2	19.3	4.27	18.2	3.84	17.2	3.48	16.6	3.34	16.1	3.20	14.9	2.93
	5.0	4.1	19.3	3.89	18.2	3.50	17.2	3.28	16.6	3.14	16.1	3.01	14.9	2.76
	7.0	6.0	19.3	3.53	18.2	3.30	17.2	3.08	16.6	2.96	16.1	2.84	14.9	2.60
	9.0	7.9	19.3	3.32	18.2	3.10	17.2	2.91	16.6	2.78	16.1	2.68	14.9	2.45
11.0	9.8	19.3	3.12	18.2	2.92	17.2	2.74	16.6	2.63	16.1	2.53	14.9	2.31	
13.0	11.8	19.3	2.94	18.2	2.75	17.2	2.57	16.6	2.47	16.1	2.37	14.9	2.18	
15.0	13.7	19.3	2.77	18.2	2.59	17.2	2.44	16.6	2.33	16.1	2.24	14.9	2.05	

Abbreviations:  
 TC: Total capacity (kW)  
 PI: Power input (compressor + outdoor fan motor) (kW)

## 9 Operating Limits

Figure 2-9.1: Cooling operating limits

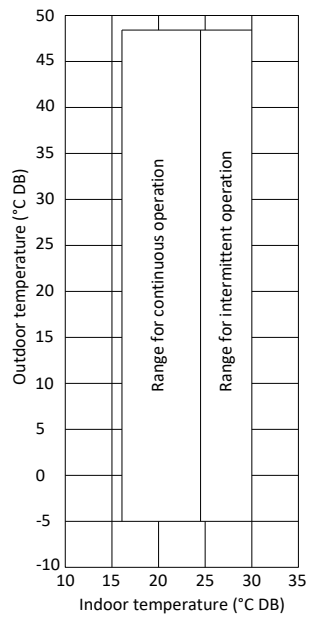
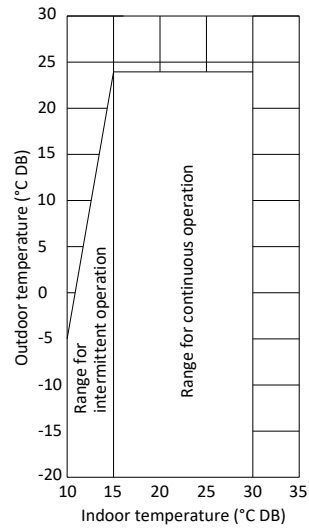

Figure 2-9.2: Heating operating limits



Notes:

1. These figures assume the following operating conditions:
  - Equivalent piping length: 7.5m
  - Level difference: 0



## 10 Sound Levels

### 10.1 Overall

Table 2-10.1: Sound pressure level

Model	dB(A)	Model	dB(A)	Model	dB(A)	Model	dB(A)
8HP	58	28HP	65	48HP	67	68HP	68
10HP	59	30HP	65	50HP	67	70HP	69
12HP	60	32HP	65	52HP	67	72HP	69
14HP	62	34HP	65	54HP	67	74HP	69
16HP	62	36HP	66	56HP	67	76HP	69
18HP	63	38HP	66	58HP	68	78HP	69
20HP	63	40HP	66	60HP	68	80HP	70
22HP	63	42HP	66	62HP	68	82HP	70
24HP	64	44HP	66	64HP	68	84HP	70
26HP	65	46HP	66	66HP	68	86HP	70
						88HP	70

- Notes:
1. Sound pressure level is measured at a position 1m in front of the unit and 1.3m above the floor in a semi-anechoic chamber. During in-situ operation, sound pressure levels may be higher as a result of ambient noise.

Figure 2-10.1: Sound pressure level measurement (unit: mm)

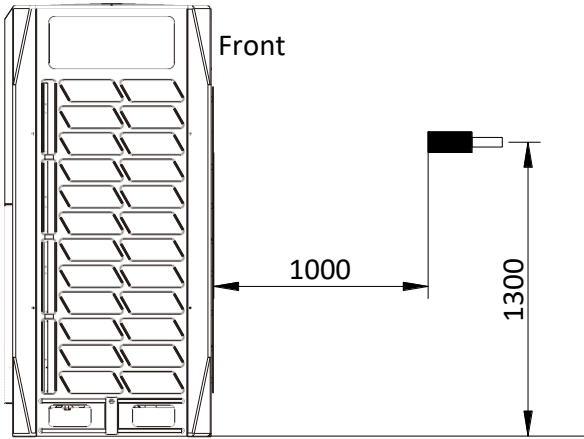

### 10.2 Octave Band Levels

Figure 2-10.2 VMEX008Q8A-D13V224 octave band level

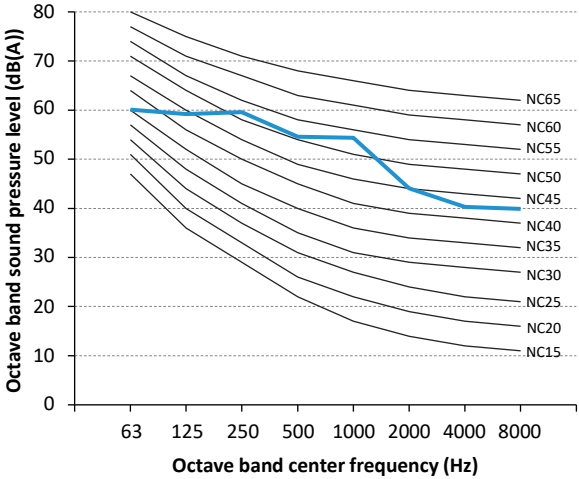
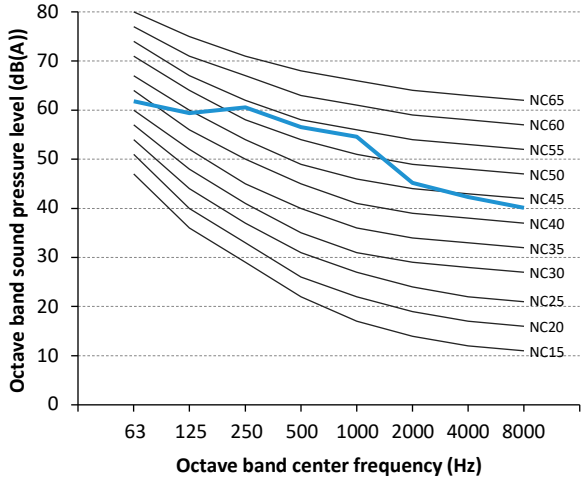

Figure 2-10.3 VMEX009Q8A-D16V280 octave band level



# VMEX 460V 60Hz

Figure 2-10.4 VMEX010Q8A-D20V335 octave band level

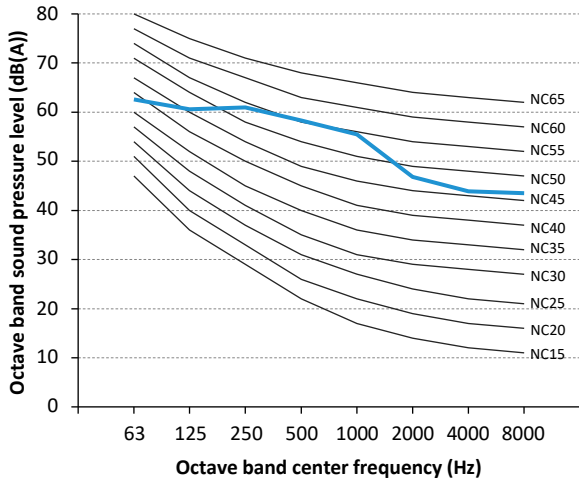

Figure 2-10.5 VMEX012Q8A-D23V400 octave band level

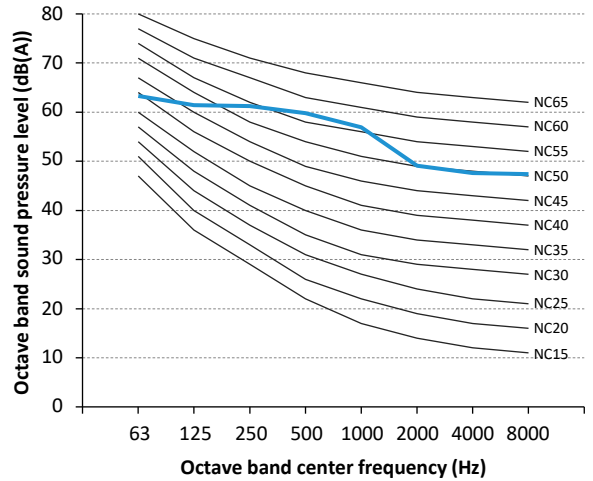

Figure 2-10.6 VMEX014Q8A-D26V450 octave band level

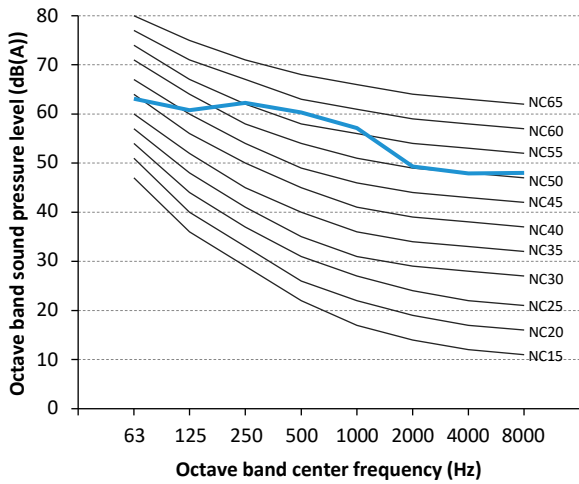

Figure 2-10.7 VMEX016Q8A-D29V500 octave band level

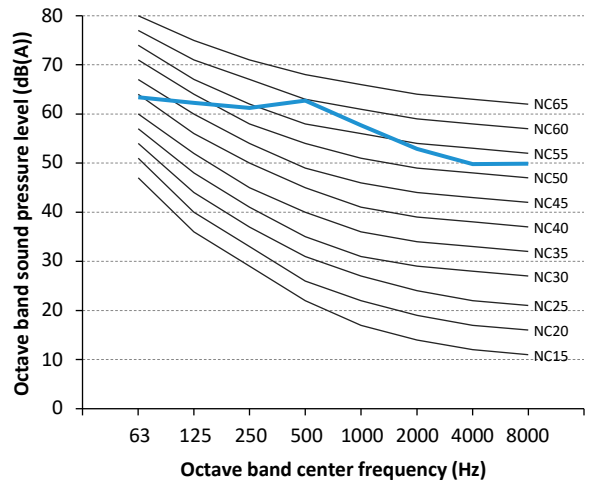

Figure 2-10.8 VMEX018Q8A-D33V560 octave band level

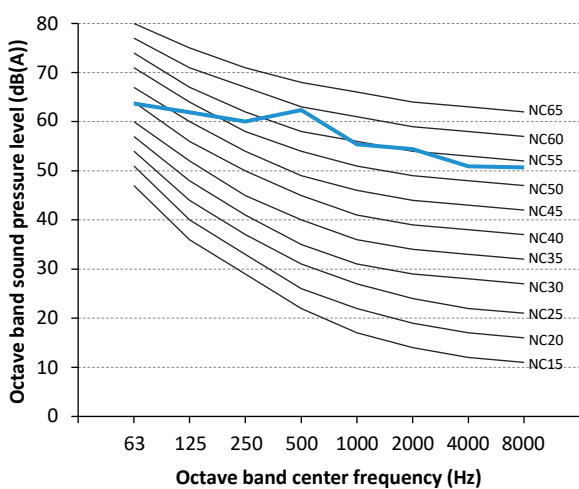
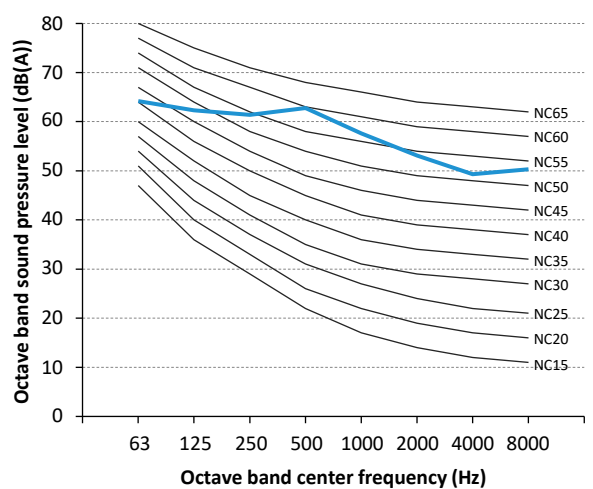







Figure 2-10.9 VMEX020Q8A-D36V615 octave band level



## 11 Accessories

### 11.1 Standard Accessories

Table 2-11.1: Standard accessories

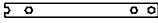
Name	Shape	Quantity	Function
Outdoor unit installation manual		1	
Outdoor unit owner's manual		1	
Indoor unit owner's manual		2	
Flat-blade screwdriver	-	1	Adjusting indoor and outdoor unit dial switches
90° elbow		1	Connecting pipes
Seal plug		8	Used in pipe flushing
Connection pipe		3	Connecting pipes
Matched resistor		2	Enhances communication stability
Wrench		1	Removing side plate
Accessory bag	-	1	

### 11.2 Optional Accessories

Table 2-11.2: Optional accessories

Optional accessories	Model	Packed dimensions (mm)	Net/gross weight (kg)	Function
Outdoor branch joint kits	VAMC002-DDF	255×150×185	1.2/1.5	Distribute refrigerant to indoor units and balance flow resistance between outdoor units
	VAMC003-DDF	345×160×285	2.4/3.4	
	VAMC004-DDF	475×165×300	3.6/4.8	
Indoor branch joint kits	VAPC060-D01	290×105×100	0.3/0.4	
	VAPC102-D02	290×105×100	0.4/0.6	
	VAPC240-D03	310×130×125	0.6/0.9	
	VAPC460-D04	350×170×180	1.1/1.5	
	VAPC835-D05	365×195×215	1.4/1.9	

# Part 3

## System Design and Installation

1	Preface to Part 3 .....	158
2	Unit Placement and Installation.....	159
3	Outdoor Unit Ducting and Shielding .....	162
4	Refrigerant Piping Design.....	166
5	Refrigerant Piping Installation.....	176
6	Drain Piping .....	188
7	Insulation .....	191
8	Charging Refrigerant .....	193
9	Electrical Wiring.....	195
10	Installation in Areas of High Salinity .....	199
11	Commissioning .....	200
12	Appendix to Part 3 – System Commissioning Report .....	202

## 1 Preface to Part 3

### 1.1 Notes for Installers Boxes

The information contained in this Engineering Data Book may primarily be of use during the system design stage of a Omega VMEX Series VRF project. Additional important information which may primarily be of use during field installation has been placed in boxes, such as the example below, titled “Notes for installers”.

#### Notes for installers



- Notes for installers boxes contain important information which may primarily be of use during field installation, rather than during desk-based system design.

### 1.2 Definitions

In this Engineering Data Book, the term “applicable legislation” refers to all national, local and other laws, standards, codes, rules, regulations and other legislation that apply in a given situation.

### 1.3 Precautions

All system installation including installation of piping and electrical works must only be carried out by competent and suitably qualified, certified and accredited professionals and in accordance with all applicable legislation.

## 2 Unit Placement and Installation

### 2.1 Outdoor Units

#### 2.1.1 Placement considerations

Placement of outdoor units should take account of the following considerations:

- Air conditioners should not be exposed to direct radiation from a high-temperature heat source.
- Air conditioners should not be installed in positions where dust or dirt may affect heat exchangers.
- Air conditioners should not be installed in locations where exposure to oil or to corrosive or harmful gases, such as acidic or alkaline gases, may occur.
- Air conditioners should not be installed in locations where exposure to salinity may occur unless the anti-corrosion treatment for high-salinity areas customization option has been added and the precautions described in Part 3, 10 “Installation in Areas of High Salinity” are taken.
- Outdoor units should be installed in well-drained, well-ventilated positions that are as close as possible to the indoor units.

#### 2.1.2 Spacing

Outdoor units must be spaced such that sufficient air may flow through each unit. Sufficient airflow across heat exchangers is essential for outdoor units to function properly. Figures 3-2.1 to 3-2.3 show spacing requirements in three different scenarios.

If the particular circumstances of an installation require a unit to be placed closer to a wall than specified in Figures 3-2.1 to 3-2.3, a discharge duct should be installed. Refer to Part 3, 3 “Outdoor Unit Ducting and Shielding”. Depending on the height of adjacent walls relative to the height of the units, ducting may be required. Refer to Part 3, 3 “Outdoor Unit Ducting and Shielding”.

Figure 3-2.1: Single unit installation (unit: mm)

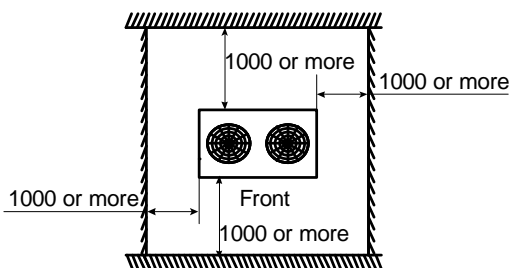

Figure 3-2.2: Single row installation (unit: mm)

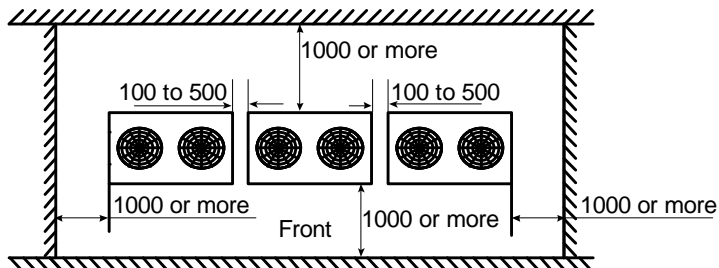
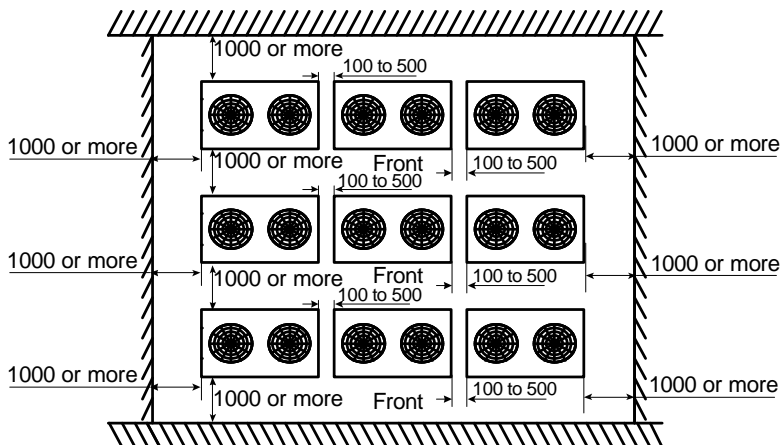

Figure 3-2.3: Multi-row installation (unit: mm)



## VMEX VRF 460V 60Hz

### 2.1.3 Master and slave unit positioning

In systems with multiple outdoor units, the units should be placed in order from largest capacity unit to smallest capacity unit. The largest capacity unit must be placed on the first branch, and be set as the master unit, while the others should be set as slave units. Refer to the V5 X Service Manual, Part 4 for details of how to set units as master/slave.

The example in Figure 3-2.4 illustrates the placing of units in a 48HP combination:

- Place the 22HP unit on the first branch and set it as the master unit.
- Place the 16HP and 10HP units on the next branches and set them as slave units.

Figure 3-2.4: Positioning of master and slave units

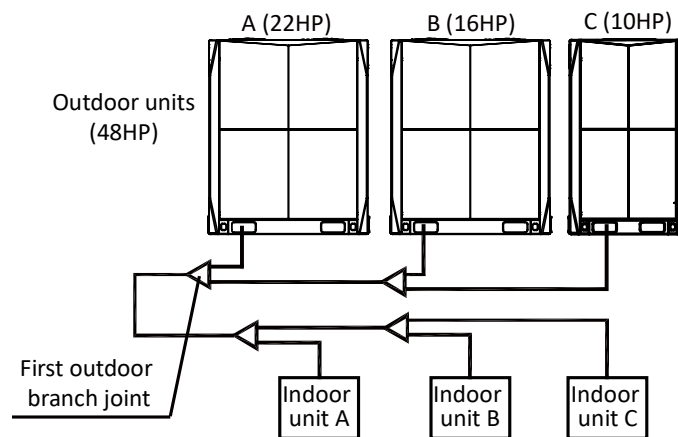

### 2.1.4 Base structures

Outdoor unit base structure design should take account of the following considerations:

- A solid base prevents excess vibration and noise. Outdoor unit bases should be constructed on solid ground or on structures of sufficient strength to support the units' weight.
- Bases should be at least 200mm high to provide sufficient access for installation of piping.
- Either steel or concrete bases may be suitable.
- A typical concrete base design is shown in Figure 3-2.5. A typical concrete specification is 1 part cement, 2 parts sand and 4 parts crushed stone with  $\Phi 10\text{mm}$  steel reinforcing bar. The edges of the base should be chamfered.
- To ensure that all contact points are equally secure, bases should be completely level. Base design should ensure that the points on the units' bases designed for weight-bearing support are fully supported. Bolt spacings should be as per Figure 3-2.6 and Table 3-2.1.
- A drainage ditch should be provided to allow drainage of condensate that may form on the heat exchangers when the units are running in heating mode. The drainage should ensure that condensate is directed away from roadways and footpaths, especially in locations where the climate is such that condensate may freeze.

Figure 3-2.5: Outdoor unit typical concrete base structure design (unit: mm)

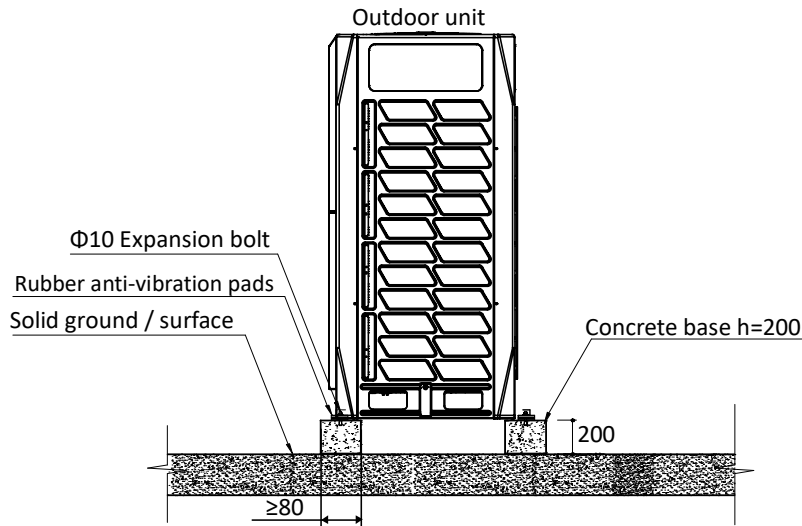

Figure 3-2.6: Expansion bolt positioning

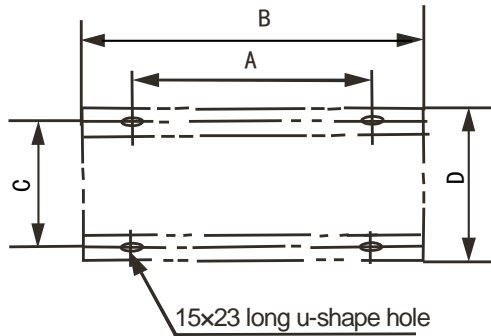

Table 3-2.1: Expansion bolt spacings

Dimension (mm)	8, 10, 12HP	14, 16, 18, 20, 22HP
A	740	1090
B	990	1340
C	723	723
D	790	790

### 2.1.5 Acceptance and unpacking

#### Notes for installers



- When units are delivered check whether any damage occurred during shipment. If there is damage to the surface or outside of a unit, submit a written report to the shipping company.
- Check that the model, specifications and quantity of the units delivered are as ordered.
- Check that all accessories ordered have been included. Retain the Owner's Manual for future reference.

### 2.1.6 Hoisting

#### Notes for installers



- Do not remove any packaging before hoisting. If units are not packaged or if the packaging is damaged, use suitable boards or packing material to protect the units.
- Hoist one unit at a time, using two ropes to ensure stability.
- Keep units upright during hoisting, ensuring that the angle to the vertical does not exceed 30°.



## 2.2 Indoor Units

### 2.2.1 Placement considerations

Placement of indoor units should take account of the following considerations:

- Sufficient space for drain piping and for access during servicing and maintenance should be allowed.
- To ensure a good cooling/heating effect, short-circuit ventilation (where outlet air returns quickly to a unit's air inlet) should be avoided.
- To prevent excessive noise or vibration during operation, suspension rods or other weight-bearing fixings should typically be able to bear twice the unit's weight.

### Notes for installers



- Before installing an indoor unit, check that the model to be installed is as specified in the construction drawings and confirm the correct orientation of the unit.
- Ensure that units are installed at the correct height.
- To allow smooth condensate drainage and to ensure unit stability (to prevent excessive noise or vibration), ensure that units are level to within 1° of the horizontal. If a unit is not level to within 1° of the horizontal, water leakage or abnormal vibration/noise may occur.

## 3 Outdoor Unit Ducting and Shielding

### 3.1 Ducting Requirements

Depending on the height of adjacent walls relative to the height of the units, ducting may be required to ensure proper air discharge. In the situation depicted in Figure 3-3.1, the vertical section of ducting should be at least H-h high.

Figure 3-3.1: Top of unit below top of adjacent wall

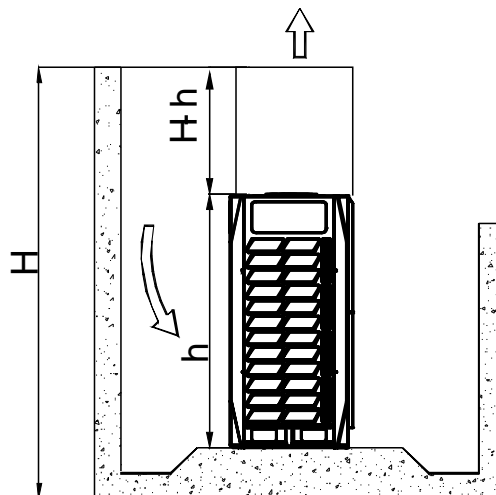

### 3.2 Design Considerations

Outdoor unit ducting design should take account of the following:

- Each duct should contain no more than one bend.
- Vibration isolation should be added to the connection between the unit and the ducting to avoid vibration/noise.
- Installing louvers is not recommended as doing so decreases airflow, impacting upon cooling/heating performance and energy efficiency. If the installation situation necessitates louvers, they should be installed at an angle no greater than 15° to the horizontal, to minimize the impact on airflow.

### 3.3 Ducting for VMEX008(009,010)Q8A Units

#### 3.3.1 Option A – Transverse ducting

Figure 3-3.2: Transverse ducting for VMEX008(009,010)Q8A units (unit: mm)

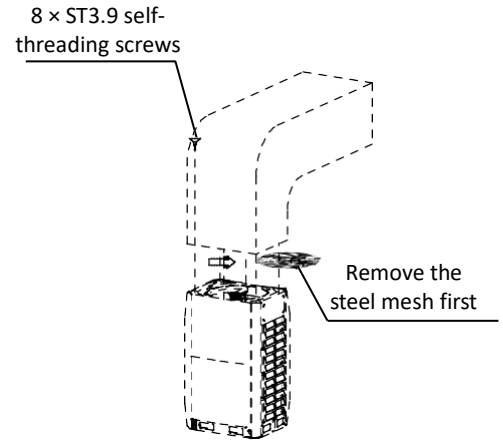
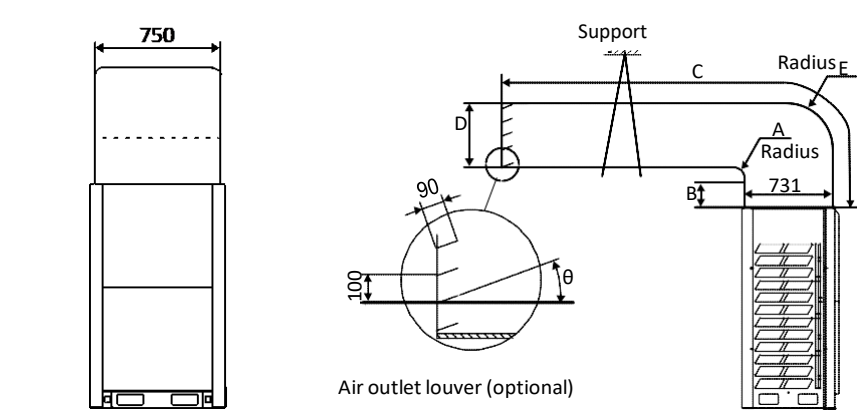
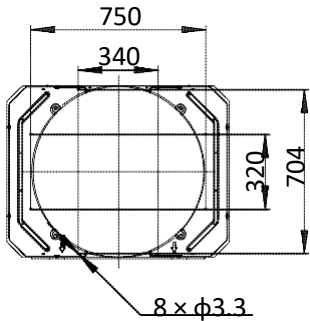

Table 3-3.1: Duct dimensions

Dimensions (mm)	
A	$A \geq 300$
B	$B \geq 250$
C	$C \leq 3000$
D	$731 \leq D \leq 770$
E	$E = A + 731$
$\theta$	$\theta \leq 15^\circ$

Table 3-3.2: External static pressure

ESP (Pa)	Remarks
0	Factory default
0 – 20	Remove steel mesh and connect to duct < 3m long
> 20	Customization option



#### 3.3.2 Option B – Longitudinal ducting

Figure 3-3.3: Longitudinal ducting for VMEX008,009,010 units (unit: mm)

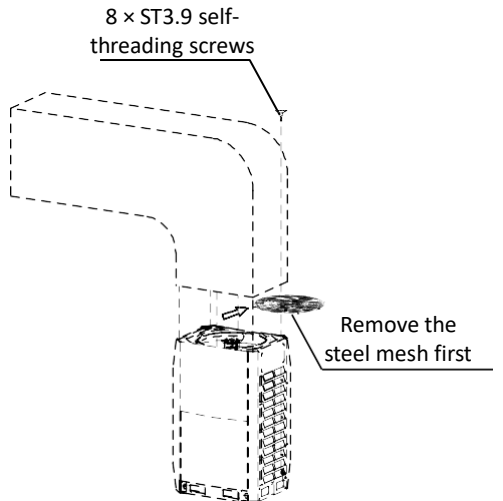
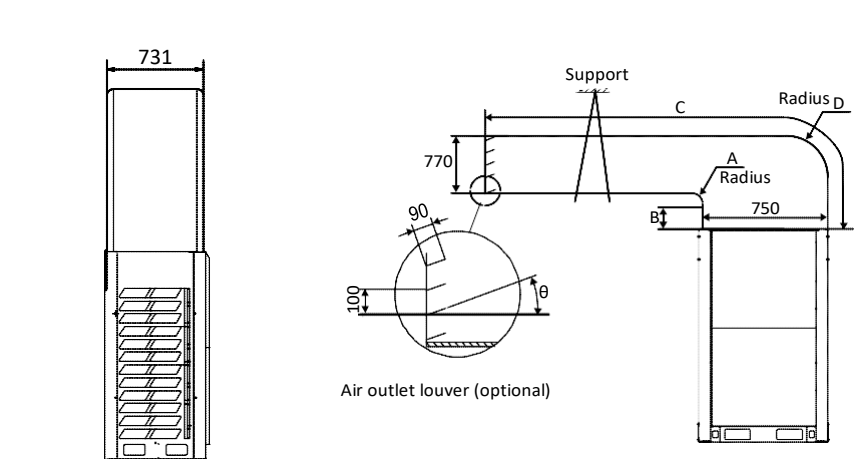
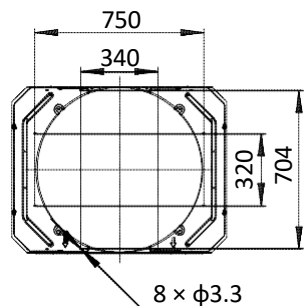

Table 3-3.3: Duct dimensions

Dimensions (mm)	
A	$A \geq 300$
B	$B \geq 250$
C	$C \leq 3000$
D	$D = A + 750$
$\theta$	$\theta \leq 15^\circ$

Table 3-3.4: External static pressure

ESP (Pa)	Remarks
0	Factory default
0 – 20	Remove steel mesh and connect to duct < 3m long
> 20	Customization option



### 3.4 Ducting for VMEX012(014,016,018,020)Q8A Units

#### 3.4.1 Option A – Transverse ducting

Figure 3-3.4: Transverse ducting for VMEX012(014,016,018,020)Q8A units (unit: mm)

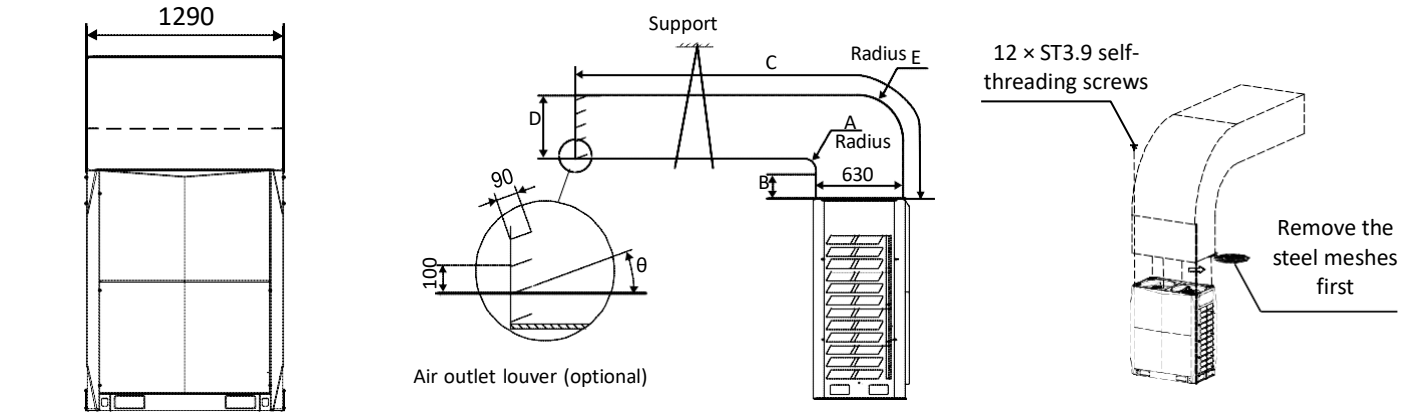

Table 3-3.5: Duct dimensions

Dimensions (mm)	
A	$A \geq 300$
B	$B \geq 250$
C	$C \leq 3000$
D	$630 \leq D \leq 660$
E	$E = A + 630$
$\theta$	$\theta \leq 15^\circ$

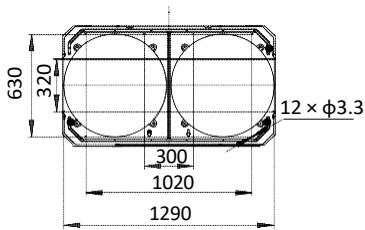

Table 3-3.6: External static pressure

ESP (Pa)	Remarks
0	Factory default
0 – 20	Remove steel mesh and connect to duct < 3m long
> 20	Customization option

#### 3.4.2 Option B – Longitudinal ducting

Figure 3-3.5: Longitudinal ducting for 14HP, 16HP, 18HP, 20HP and 22HP units (unit: mm)

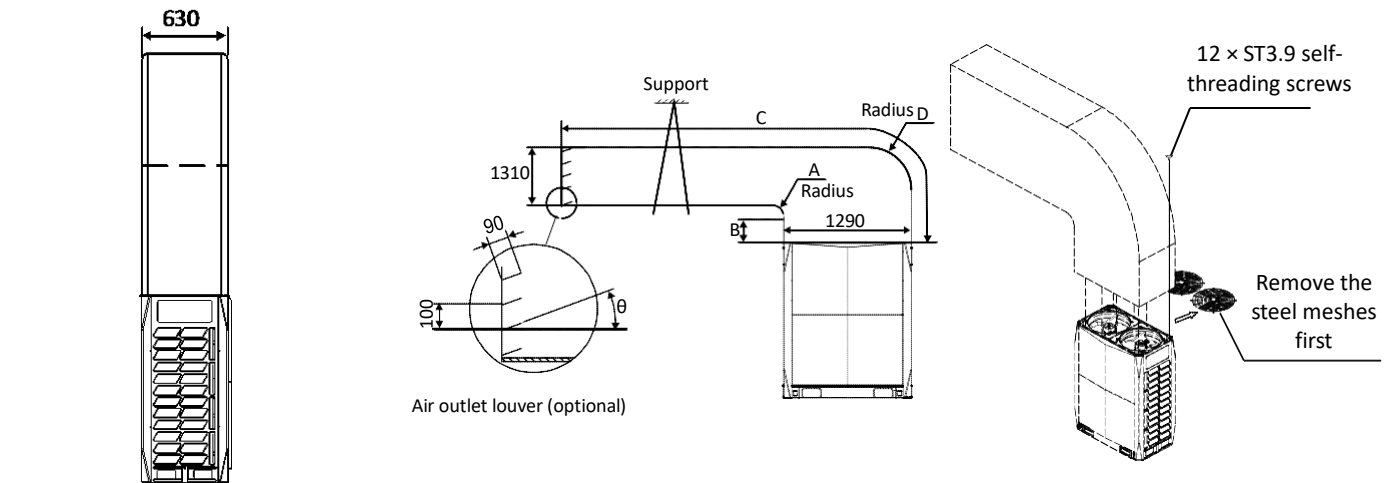

Table 3-3.7: Duct dimensions

Dimensions (mm)	
A	$A \geq 300$
B	$B \geq 250$
C	$C \leq 3000$
D	$D = A + 1290$
$\theta$	$\theta \leq 15^\circ$

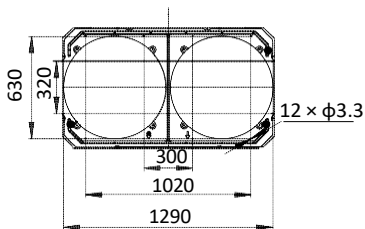

Table 3-3.8: External static pressure

ESP (Pa)	Remarks
0	Factory default
0 – 20	Remove steel mesh and connect to duct < 3m long
> 20	Customization option

### 3.5 Fan Performance

The default external static pressure of outdoor units' air outlets is zero. With the steel mesh cover removed the external static pressure is 20Pa. With customization options, external static pressure can be increased to 40Pa.

Figure 3-3.6: VMEX008(009) units fan performance

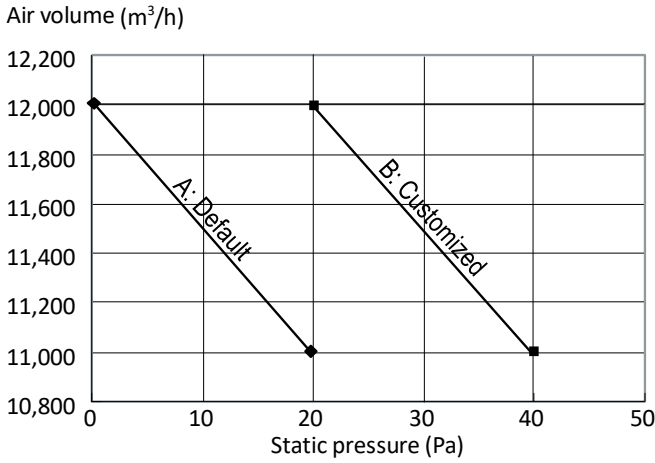

Figure 3-3.7: VMEX010 units fan performance

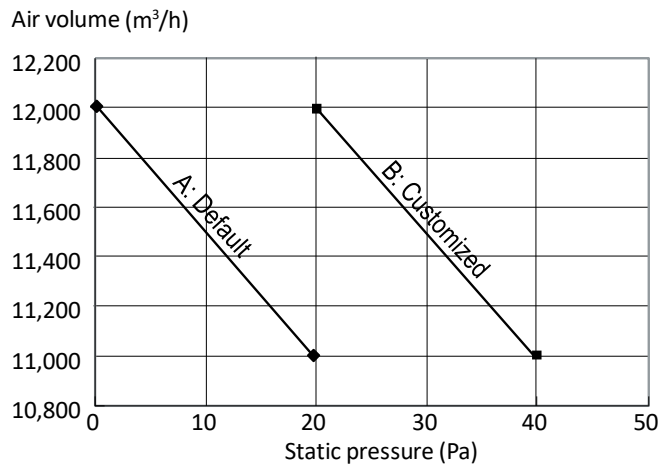

Figure 3-3.8: VMEX012(014) units fan performance

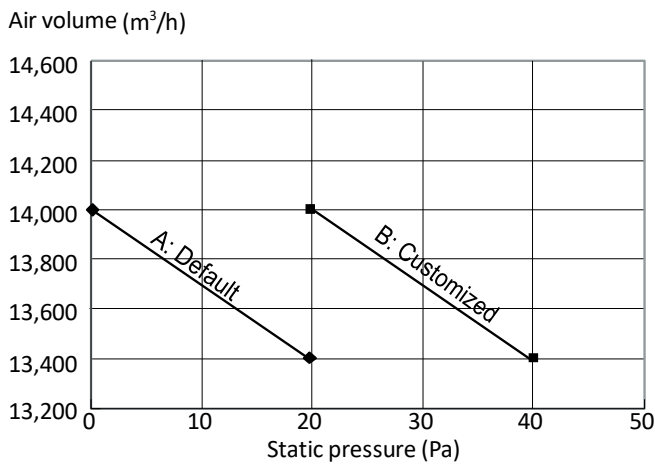

Figure 3-3.9: VMEX016 units fan performance

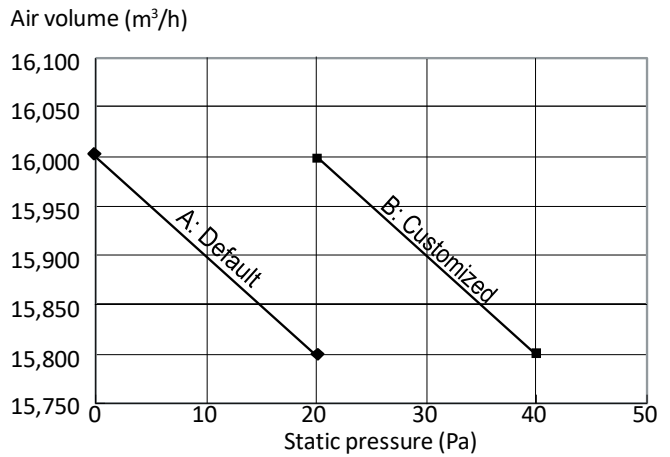
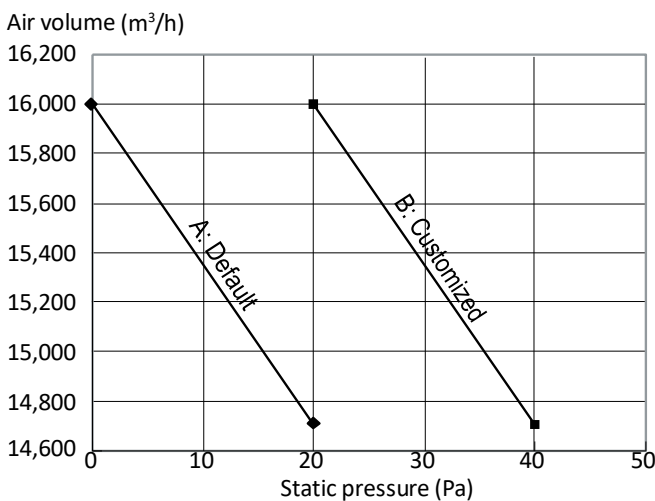

Figure 3-3.10: VMEX018(020) units fan performance



#### Notes for installers



- Before installing outdoor unit ducting, be sure to remove the unit's steel mesh cover, otherwise airflow will be adversely affected.

## 3.6 Snow Shielding

In areas of high snowfall, snow shields should be installed on air inlets and outlets to prevent snow from entering the units. Additionally, the height of the base structures should be increased so as to raise the units further off the ground.

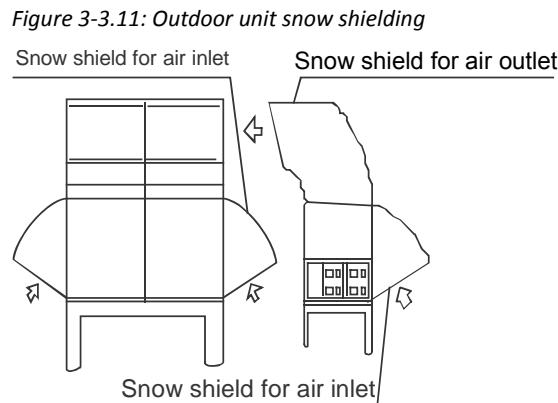

## 4 Refrigerant Piping Design

### 4.1 Design Considerations

Refrigerant piping design should take account of the following considerations:

- The amount of brazing required should be kept to a minimum.
- On the two inside sides of the first indoor branch joint ("A" in Figures 3-4.2, 3-4.3 and 3-4.4) the system should, as far as possible, be equal in terms of number of units, total capacities and total piping lengths.

### 4.2 Material Specification

Only seamless phosphorus-deoxidized copper piping that complies with all applicable legislation should be used. Temper grades and minimum thicknesses for different diameters of piping are specified in Table 3-4.1.

Table 3-4.1: Piping temper and thickness

Piping outer diameter (mm)	Temper <sup>1</sup>	Minimum thickness (mm)
Φ6.35	O (annealed)	0.8
Φ9.53		0.8
Φ12.7		0.8
Φ15.9		1.0
Φ19.1		1.0
Φ22.2	1/2H (half hard)	1.2
Φ25.4		1.2
Φ28.6		1.3
Φ31.8		1.5
Φ38.1		1.5
Φ41.3		1.5
Φ44.5		1.5
Φ54.0		1.8

Notes:

1. O: coiled piping; 1/2H: straight piping.

### 4.3 Permitted Piping Lengths and Level Differences

The piping length and level difference requirements that apply are summarized in Table 3-4.3 and are fully described as follows (refer to Figure 3-4.2):

1. **Requirement 1:** The total length of piping in one refrigerant system should not exceed 1000m. When calculating the total length of piping, the actual length of the indoor main pipes (the piping between the first indoor branch joint and all other indoor branch joints,  $L_2$  to  $L_{12}$ ) should be doubled.
2. **Requirement 2:** The piping between the farthest indoor unit ( $N_9$ ) and the first outdoor branch joint (N) should not exceed 175m (actual length) and 200m (equivalent length). (The equivalent length of each branch joint is 0.5m.)
3. **Requirement 3:** The piping between the farthest indoor unit ( $N_9$ ) and first indoor branch joint (A) should not exceed 40m in length ( $\sum\{L_7 \text{ to } L_{10}\} + i \leq 40\text{m}$ ) unless the following conditions are met and the following measures are taken, in which case the permitted length is up to 90m:

**Conditions:**

- a) Each indoor auxiliary pipe (from each indoor unit to its nearest branch joint) joint does not exceed 20m in length ( $a \text{ to } m \text{ each } \leq 20\text{m}$ ).
- b) The difference in length between {the piping from first indoor branch joint (A) to the farthest indoor unit ( $N_9$ )} and {the piping from the first indoor branch joint (A) to the nearest indoor unit ( $N_1$ )} does not exceed 40m. That is:  $(\sum\{L_7 \text{ to } L_{10}\} + i) - (\sum\{L_2 \text{ to } L_3\} + a) \leq 40\text{m}$ .

**Measures:**

- a) Increase the diameter of the indoor main pipes (the piping between the first indoor branch joint and all other indoor branch joints,  $L_2$  to  $L_{12}$ ) as per Table 3-4.2, except for indoor main pipes which are already the same size as the main pipe ( $L_1$ ), for which no diameter increases are required.
4. **Requirement 4:** The largest level difference between indoor unit and outdoor unit should not exceed 90m (if the outdoor unit is above) or 110m (if the outdoor unit is below). Additionally: (i) If the outdoor unit is above and the level difference is greater than 20m, it is recommended that an oil return bend with dimensions as specified in Figure 3-4.1 is set every 10m in the gas pipe of the main pipe; and (ii) if the outdoor unit is below and the level difference is more than 40m, the liquid pipe of the main pipe ( $L_1$ ) should be increased as per Table 3-4.2.
  5. **Requirement 5:** The largest level difference between indoor units should not exceed 30m.

Table 3-4.2: Diameter increase requirements

Original (mm)	Increased (mm)
Φ9.53	Φ12.7
Φ12.7	Φ15.9
Φ15.9	Φ19.1
Φ19.1	Φ22.2
Φ22.2	Φ25.4
Φ25.4	Φ28.6
Φ28.6	Φ31.8
Φ31.8	Φ38.1
Φ38.1	Φ41.3
Φ41.3	Φ44.5
Φ44.5	Φ54.0

Figure 3-4.1: Oil return bend (unit: mm)

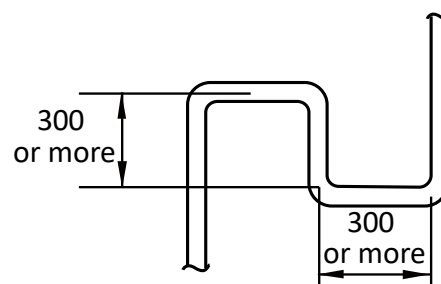

# VMEX VRF 460V 60Hz

Figure 3-4.2: Permitted refrigerant piping lengths and level differences

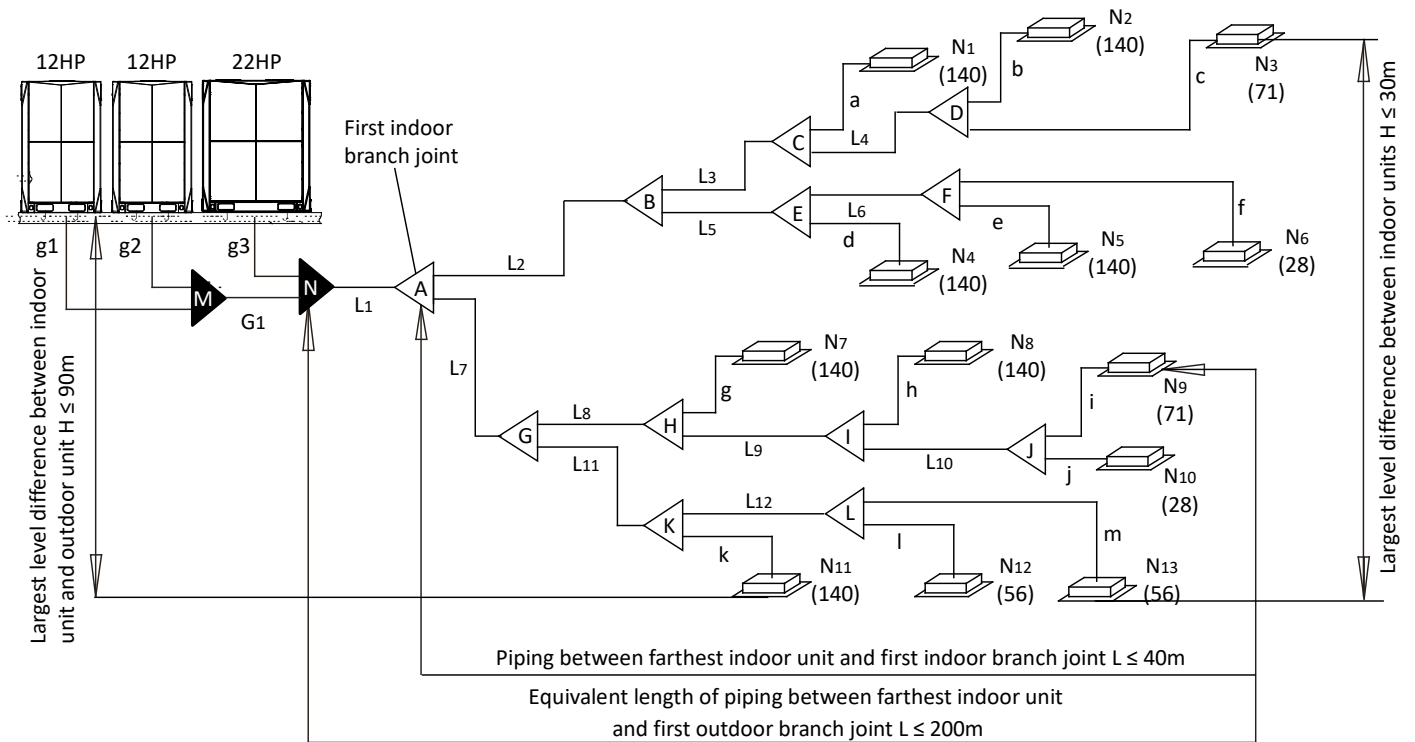

Legend		
L <sub>1</sub>	Main pipe	Figures in parentheses indicate indoor unit capacity indexes.
L <sub>2</sub> to L <sub>12</sub>	Indoor main pipes	
a to m	Indoor auxiliary pipes	
A to L	Indoor branch joints	
M, N	Outdoor branch joints	
g1 to g3, G <sub>1</sub>	Outdoor connection pipes	

Table 3-4.3: Summary of permitted refrigerant piping lengths and level differences

		Permitted values	Piping in Figure 3-4.2
Piping lengths	Total piping length <sup>1</sup>	$\leq 1000m$	$L_1 + 2 \times \sum\{L_2 \text{ to } L_{12}\} + \sum\{a \text{ to } m\}$
	Piping between farthest indoor unit and first outdoor branch joint <sup>2</sup>	Actual length	$\leq 175m$
		Equivalent length	$\leq 200m$
Piping between farthest indoor unit and first indoor branch joint <sup>3</sup>		$\leq 40m / 90m$	$\sum\{L_7 \text{ to } L_{10}\} + i$
Level differences	Largest level difference between indoor unit and outdoor unit <sup>4</sup>	Outdoor unit is above	$\leq 90m$
		Outdoor unit is below	$\leq 110m$
	Largest level difference between indoor units <sup>5</sup>		$\leq 30m$

Notes:

1. Refer to Requirement 1, above.
2. Refer to Requirement 2, above.
3. Refer to Requirement 3, above.
4. Refer to Requirement 4, above.
5. Refer to Requirement 5, above.

### 4.4 Selecting Piping Diameters

Tables 3-4.4 to 3-4.8, below, specify the required pipe diameters for the indoor and outdoor piping. The main pipe (L<sub>1</sub>) and first indoor branch joint (A) should be sized according to whichever of Tables 3-4.4 and 3-4.5 indicates the larger size.

Figure 3-4.3: Selecting piping diameters

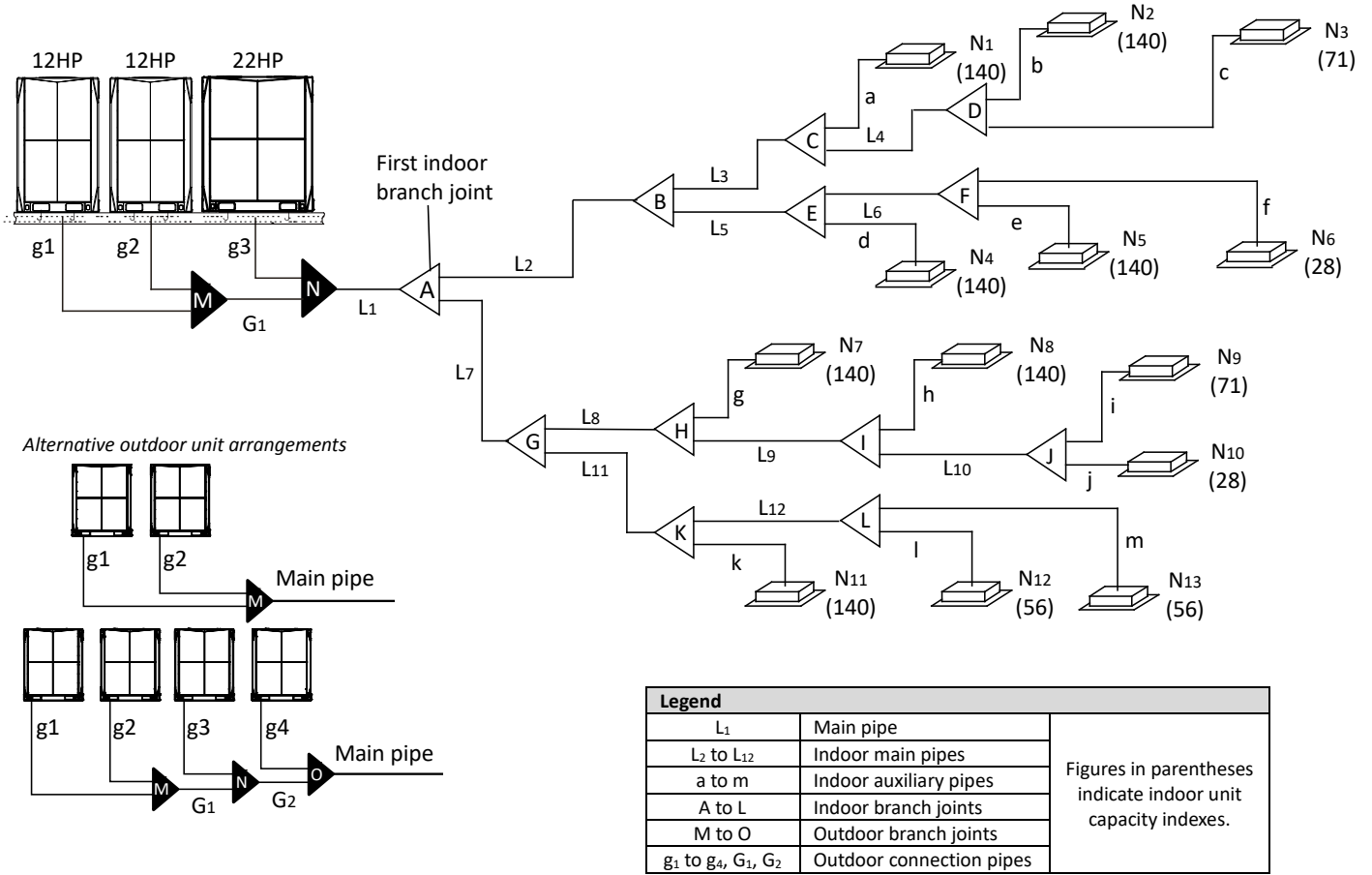

Table 3-4.4: Main pipe<sup>1</sup> (L<sub>1</sub>), indoor main pipes (L<sub>2</sub> to L<sub>12</sub>) and indoor branch joint kits

Total capacity of indoor units (kW)	Gas pipe (mm)	Liquid pipe (mm)	Branch joint kit
Capacity < 16.6	Φ15.9	Φ9.53	VAPC060-D01
16.6 ≤ Capacity < 23	Φ19.1	Φ9.53	VAPC060-D01
23 ≤ Capacity < 33	Φ22.2	Φ9.53	VAPC102-D02
33 ≤ Capacity < 46	Φ28.6	Φ12.7	VAPC240-D03
46 ≤ Capacity < 66	Φ28.6	Φ15.9	VAPC240-D03
66 ≤ Capacity < 92	Φ31.8	Φ19.1	VAPC240-D03
92 ≤ Capacity < 135	Φ38.1	Φ19.1	VAPC460-D04
135 ≤ Capacity < 180	Φ41.3	Φ22.2	VAPC835-D05
180 ≤ Capacity	Φ44.5	Φ25.4	VAPC835-D05

Notes:

- The main pipe (L<sub>1</sub>) and first indoor branch joint (A) should be sized according to whichever of Tables 3-4.4 and 3-4.5 indicates the larger size.



# VMEX VRF 460V 60Hz

Table 3-4.5: Main pipe<sup>1</sup> (L<sub>1</sub>) and first indoor branch joint (A)

Total capacity of outdoor units	Equivalent length of all liquid pipes < 90m			Equivalent length of all liquid pipes ≥ 90m		
	Gas pipe (mm)	Liquid pipe (mm)	Branch joint kit	Gas pipe (mm)	Liquid pipe (mm)	Branch joint kit
8HP	Φ22.2	Φ9.53	VAPC102-D02	Φ22.2	Φ12.7	VAPC102-D02
10HP	Φ22.2	Φ9.53	VAPC102-D02	Φ25.4	Φ12.7	VAPC102-D02
12-14HP	Φ25.4	Φ12.7	VAPC102-D02	Φ28.6	Φ15.9	VAPC240-D03
16HP	Φ28.6	Φ12.7	VAPC240-D03	Φ31.8	Φ15.9	VAPC240-D03
18-22HP	Φ28.6	Φ15.9	VAPC240-D03	Φ31.8	Φ19.1	VAPC240-D03
24HP	Φ28.6	Φ15.9	VAPC240-D03	Φ31.8	Φ19.1	VAPC240-D03
26-34HP	Φ31.8	Φ19.1	VAPC240-D03	Φ38.1	Φ22.2	VAPC460-D04
36-50HP	Φ38.1	Φ19.1	VAPC460-D04	Φ38.1	Φ22.2	VAPC460-D04
52-66HP	Φ41.3	Φ22.2	VAPC835-D05	Φ44.5	Φ25.4	VAPC835-D05
68-88HP	Φ44.5	Φ25.4	VAPC835-D05	Φ54.0	Φ25.4	VAPC920-D06

Notes:

- The main pipe (L<sub>1</sub>) and first indoor branch joint (A) should be sized according to whichever of Tables 3-4.4 and 3-4.5 indicates the larger size.

Table 3-4.6: Outdoor connection pipes (g1 to g4, G<sub>1</sub>, G<sub>2</sub>)

Pipes	Outdoor unit capacity	Gas pipe (mm)	Liquid pipe (mm)
g1 to g4	8-12HP	Φ25.4	Φ12.7
	14-22HP	Φ31.8	Φ15.9
G <sub>1</sub>		Φ38.1	Φ19.1
G <sub>2</sub>		Φ41.3	Φ22.2

Table 3-4.7: Outdoor branch joint kits (N to O)

No. of outdoor units	Branch joint kit
2	VAMC002-DDF
3	VAMC003-DDF
4	VAMC004-DDF

Table 3-4.8: Indoor auxiliary pipes (a to m)

Capacity of indoor unit (kW)	Pipe length ≤ 10m		Pipe length > 10m <sup>1</sup>	
	Gas pipe (mm)	Liquid pipe (mm)	Gas pipe (mm)	Liquid pipe (mm)
≤ 4.5	Φ12.7	Φ6.35	Φ15.9	Φ9.53
≥ 5.6	Φ15.9	Φ9.53	Φ19.1	Φ12.7

Notes:

- An indoor auxiliary pipe should not be larger than the indoor main pipe immediately upstream of it. For indoor auxiliary pipes greater than 10m in length with indoor units of capacity great than or equal to 5.6kW, the gas and liquid side pipes should each either be sized according to this table, or else be the same size as the indoor main pipe immediately upstream, whichever is smaller.

### 4.5 Refrigerant Piping Selection Example

The example below illustrates the piping selection procedure for a system consisting of three outdoor units (22HP + 12HP + 12HP) and 13 indoor units.

Figure 3-4.4: Refrigerant piping selection example

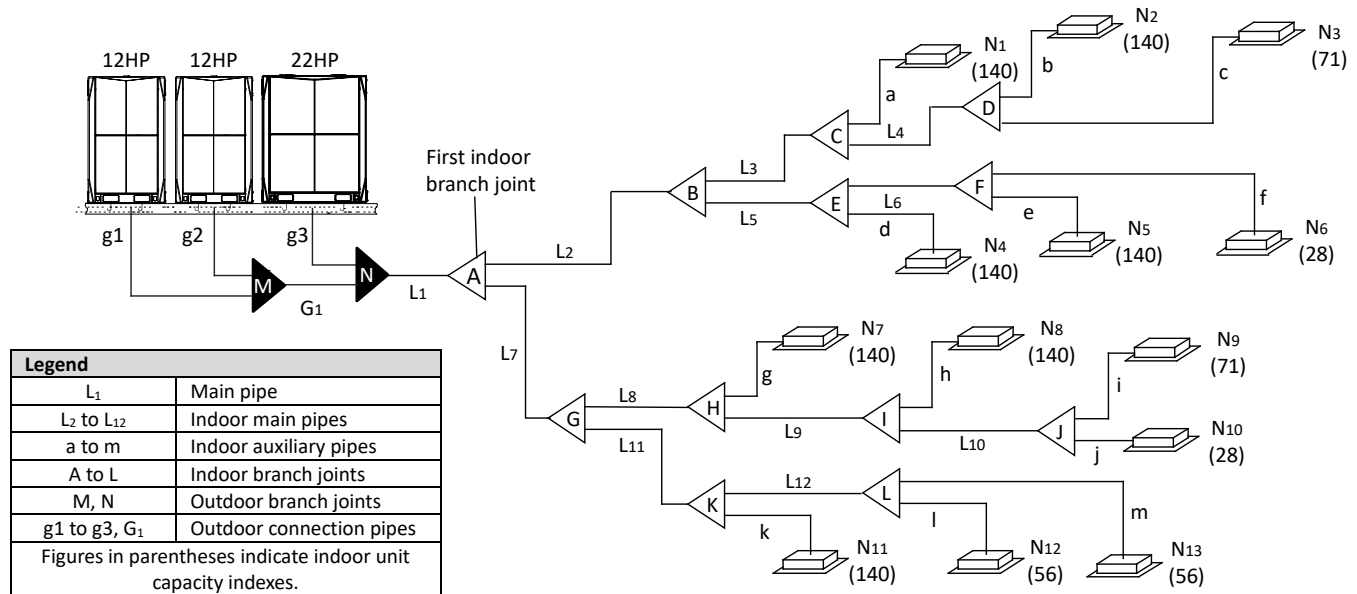

#### Condition 1:

- Equivalent length of all liquid pipes is in excess of 90m;
- Piping between the farthest indoor unit and the first indoor branch joint is **less than 40m** in length;
- Each indoor auxiliary pipe (from each indoor unit to its nearest branch joint) is less than 10m in length.

#### Step 1: Select indoor auxiliary pipes

- Indoor units N<sub>1</sub> to N<sub>5</sub>, N<sub>7</sub> to N<sub>9</sub> and N<sub>11</sub> to N<sub>13</sub> are of capacity 5.6kW or greater and their indoor auxiliary pipes are less than 10m in length. Refer to Table 3-4.8. Indoor auxiliary pipes a to e, g to i, and k to m are Φ15.9 / Φ9.53.
- Indoor units N<sub>6</sub> and N<sub>10</sub> are of capacity less than 4.5kW and their indoor auxiliary pipes are less than 10m in length. Refer to Table 3-4.8. Indoor auxiliary pipes f and j are Φ12.7 / Φ6.35.

#### Step 2: Select indoor main pipes and indoor branch joints B to L

- The indoor units (N<sub>2</sub> and N<sub>3</sub>) downstream of indoor branch joint D have total capacity of 14 + 7.1 = 21.1kW. Refer to Table 3-4.4. Indoor main pipe L<sub>4</sub> is Φ19.1 / Φ9.53. Indoor branch joint D is VAPC060-D01.
- The indoor units (N<sub>1</sub> to N<sub>6</sub>) downstream of indoor branch joint B have total capacity of 14 x 4 + 7.1 + 2.8 = 65.9kW. Refer to Table 3-4.4. Indoor main pipe L<sub>2</sub> is Φ28.6 / Φ15.9. Indoor branch joint B is VAPC240-D03.
- The other indoor main pipes and indoor branch joints C and E to L are selected in the same fashion.

#### Step 3: Select main pipe and indoor branch joint A

- The indoor units (N<sub>1</sub> to N<sub>13</sub>) downstream of indoor branch joint A have total capacity of 14 x 7 + 7.1 x 2 + 5.6 x 2 + 2.8 x 2 = 129kW. The system's equivalent length of all liquid pipes is in excess of 90m. The total capacity of the outdoor units is 22 + 12 + 12 = 46HP. Refer to Tables 3-4.4 and 3-4.5. Main pipe L<sub>1</sub> is the larger of Φ38.1 / Φ19.1 and Φ38.1 / Φ22.2, hence Φ38.1 / Φ22.2. Indoor branch joint A is VAPC460-D04.

#### Step 4: Select outdoor connection pipes and outdoor branch joints

- The master unit is 22HP and the slave units are 12HP. Refer to Table 3-4.6. Outdoor connection pipes g<sub>1</sub> and g<sub>2</sub> are Φ25.4 / Φ12.7 and outdoor connection pipe g<sub>3</sub> is Φ31.8 / Φ15.9.
- Refer to Table 3-4.6. Outdoor connection pipe G<sub>1</sub> is Φ38.1 / Φ19.1.
- There are three outdoor units in the system. Refer to Table 3-4.7. Outdoor branch joints M and N are VAMC003-DDF.

#### Condition 2:

- Equivalent length of all liquid pipes is in excess of 90m;
- Piping length between the farthest indoor unit and the first indoor branch joint is **more than 40m and less than 90m**;

## VMEX VRF 460V 60Hz

- The difference in length between {the piping from first indoor branch joint (A) to the farthest indoor unit (N9)} and {the piping from the first indoor branch joint (A) to the nearest indoor unit (N1)} does not exceed 40m. That is:  $(\Sigma\{L7 \text{ to } L10\} + i) - (\Sigma\{L2 \text{ to } L3\} + a) \leq 40\text{m}$ .
- Each indoor auxiliary pipe (a to m) is less than 10m in length.

### Step 1: Select indoor auxiliary pipes

- Indoor units N<sub>1</sub> to N<sub>5</sub>, N<sub>7</sub> to N<sub>9</sub> and N<sub>11</sub> to N<sub>13</sub> are of capacity 5.6kW or greater and their indoor auxiliary pipes are less than 10m in length. Refer to Table 3-4.8. Indoor auxiliary pipes a to e, g to i, and k to m are  $\Phi 15.9 / \Phi 9.53$ .
- Indoor units N<sub>6</sub> and N<sub>10</sub> are of capacity less than 4.5kW and their indoor auxiliary pipes are less than 10m in length. Refer to Table 3-4.8. Indoor auxiliary pipes f and j are  $\Phi 12.7 / \Phi 6.35$ .

### Step 2: Select indoor main pipes and indoor branch joints B to L

- The indoor units (N<sub>2</sub> and N<sub>3</sub>) downstream of indoor branch joint D have total capacity of  $14 + 7.1 = 21.1\text{kW}$ . Refer to Table 3-4.4. Indoor main pipe L<sub>4</sub> is  $\Phi 19.1 / \Phi 9.53$ . Indoor branch joint D is VAPC060-D01.
- The indoor units (N<sub>1</sub> to N<sub>6</sub>) downstream of indoor branch joint B have total capacity of  $14 \times 4 + 7.1 + 2.8 = 65.9\text{kW}$ . Refer to Table 3-4.4. Indoor main pipe L<sub>2</sub> is  $\Phi 28.6 / \Phi 15.9$ . Indoor branch joint B is VAPC240-D03.
- The other indoor main pipes and indoor branch joints C and E to L are selected in the same fashion.
- For piping length between the farthest indoor unit and the first indoor branch joints is more than 40m and all conditions are meet Requirement 3 in Part 4.3 "Permitted Piping Lengths and Level Differences", so the diameter of all indoor main pipes L<sub>2</sub> to L<sub>12</sub> should be increased on size. Refer to Table 3-4.2. For example, diameter of indoor main pipe L<sub>2</sub> is increase to  $\Phi 31.8 / \Phi 19.1$  from  $\Phi 28.6 / \Phi 15.9$ .

### Step 3: Select main pipe and indoor branch joint A

- The indoor units (N<sub>1</sub> to N<sub>13</sub>) downstream of indoor branch joint A have total capacity of  $14 \times 7 + 7.1 \times 2 + 5.6 \times 2 + 2.8 \times 2 = 129\text{kW}$ . The system's equivalent length of all liquid pipes is in excess of 90m. The total capacity of the outdoor units is  $22 + 12 + 12 = 46\text{HP}$ . Refer to Tables 3-4.4 and 3-4.5. Main pipe L<sub>1</sub> is the larger of  $\Phi 38.1 / \Phi 19.1$  and  $\Phi 38.1 / \Phi 22.2$ , hence  $\Phi 38.1 / \Phi 22.2$ . Indoor branch joint A is VAPC460-D04.

### Step 4: Select outdoor connection pipes and outdoor branch joints

- The master unit is 22HP and the slave units are 12HP. Refer to Table 3-4.6. Outdoor connection pipes g<sub>1</sub> and g<sub>2</sub> are  $\Phi 25.4 / \Phi 12.7$  and outdoor connection pipe g<sub>3</sub> is  $\Phi 31.8 / \Phi 15.9$ .
- Refer to Table 3-4.6. Outdoor connection pipe G<sub>1</sub> is  $\Phi 38.1 / \Phi 19.1$ .
- There are three outdoor units in the system. Refer to Table 3-4.7. Outdoor branch joints M and N are VAMC003-DDF.

## 4.6 Branch Joints

Branch joint design should take account of the following:

- U-shaped branch joints should be used – tee joints are not suitable. Branch joint dimensions are given in Tables 3-4.9 and 3-4.10.
- To avoid accumulation of oil in the outdoor units, outdoor branch joints should be installed horizontally and must not be higher than the outdoor unit refrigerant outlets. Refer to Figure 3-5.9 in Part 3, 5.6 "Branch Joints". Indoor branch joints may be installed either horizontally or vertically.
- To ensure even distribution of refrigerant, branch joints should not be installed within 500mm of a 90° bend, another branch joint or the straight section of piping leading to an indoor unit, with the minimum 500mm being measured from the point where the branch joint is connected to the piping, as shown in Figure 3-4.5.

Figure 3-4.5: Branch joint spacing and separation from bends (unit: mm)

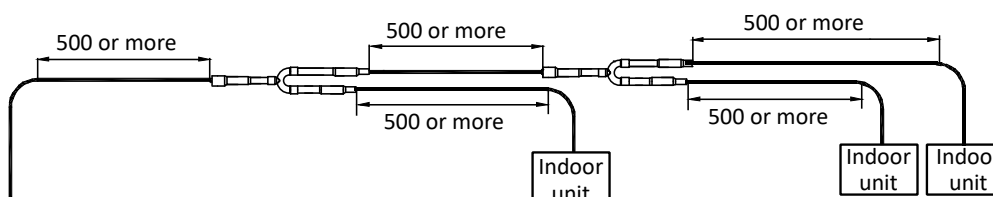

Table 3-4.9: Indoor branch joint dimensions (unit: mm)

Model	Gas side joints	Liquid side joints
VAPC060-D01		
VAPC102-D02		
VAPC240-D03		
VAPC460-D04		
VAPC835-D05		
VAPC920-D06		

# VMEX VRF 460V 60Hz

Table 3-4.10: Outdoor branch joint dimensions (unit: mm)

Model	Gas side joints	Liquid side joints
VAMC002-DDF		
VAMC003-DDF		
VAMC004-DDF		

### 4.7 Refrigerant Leakage Precautions

R410A refrigerant is not flammable in air at temperatures up to 100°C at atmospheric pressure and is generally considered a safe substance to use in air conditioning systems. Nevertheless, precautions should be taken to avoid danger to life in the unlikely event of a major refrigerant leakage. Precautions should be taken in accordance with all applicable legislation. Where no applicable legislation exists, the following may be used as a guide:

- Air conditioned rooms should be large enough that if leakage of all the refrigerant in the system occurs, the concentration of the refrigerant in the room does not reach a level dangerous to health.
- A critical concentration (at which point R410A becomes dangerous to human health) of 0.3 kg/m<sup>3</sup> can be used.
- The potential concentration of refrigerant in a room following a leak can be calculated as follows:
  - Calculate the total amount in of refrigerant in the system (“A”) as the nameplate charge (the charge in the system when delivered from the factory) plus the additional charge added as per Part 3, 8.1 “Calculating Additional Refrigerant Charge”.
  - Calculate the total volume (“B”) of the smallest room into which refrigerant could potentially leak.
  - Calculate the potential refrigerant concentration as A divided by B.
  - If A/B is not less than 0.3 kg/m<sup>3</sup>, countermeasures such installing mechanical ventilators (either ventilating regularly or controlled by refrigerant leakage detectors) should be taken.
- Since R410A is heavier than air, particular consideration should be given to leak scenarios in basement rooms.

Figure 3-4.6: Potential refrigerant leak scenario

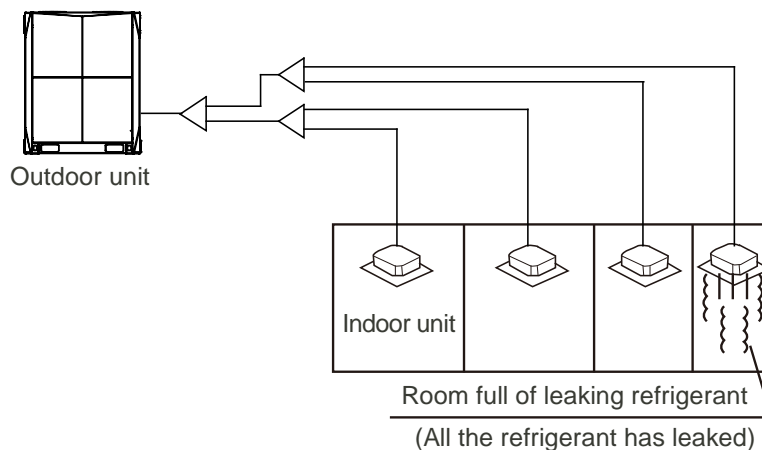
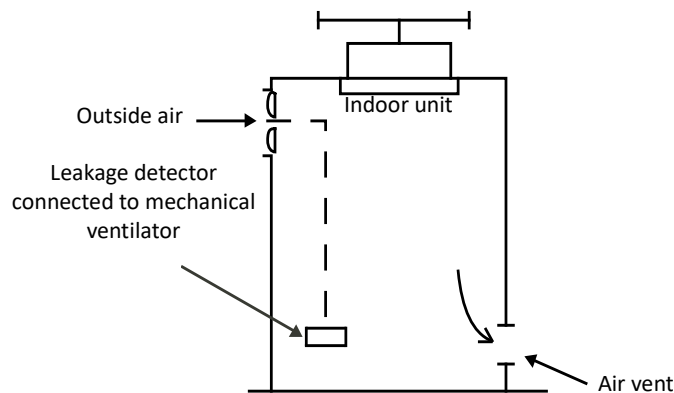

Figure 3-4.7: Mechanical ventilator controlled by refrigerant leak detector



## 5 Refrigerant Piping Installation

### 5.1 Procedure and Principles

#### 5.1.1 Installation procedure

Notes for installers

Installation of the refrigerant piping system should proceed in the following order:

Pipe insulation

Pipe brazing and installation

Pipe flushing

Gastightness test

Joint insulation

Vacuum drying

Note: Pipe flushing should be performed once the brazed connections have been completed with the exception of the final connections to the indoor units. That is, flushing should be performed once the outdoor units have been connected but before the indoor units are connected.

#### 5.1.2 Three principles for refrigerant piping

	Reasons	Measures
CLEAN	Particles such as oxide produced during brazing and/or building dust can lead to compressor malfunction	<ul style="list-style-type: none"> <li>Seal piping during storage<sup>1</sup></li> <li>Flow nitrogen during brazing<sup>2</sup></li> <li>Pipe flushing<sup>3</sup></li> </ul>
DRY	Moisture can lead to ice formation or oxidization of internal components leading to abnormal operation or compressor damage	<ul style="list-style-type: none"> <li>Pipe flushing<sup>3</sup></li> <li>Vacuum drying<sup>4</sup></li> </ul>
SEALED	Imperfect seals can lead to refrigerant leakage	<ul style="list-style-type: none"> <li>Pipe manipulation<sup>5</sup> and brazing<sup>2</sup> techniques</li> <li>Gastightness test<sup>6</sup></li> </ul>

Notes:

1. See Part 3, 5.2.1 "Pipe delivery, storage and sealing".
2. See Part 3, 5.5 "Brazing".
3. See Part 3, 5.8 "Pipe Flushing".
4. See Part 3, 5.10 "Vacuum Drying".
5. See Part 3, 5.3 "Manipulating Copper Piping".
6. See Part 3, 5.9 "Gastightness Test".

## 5.2 Storing Copper Piping

### 5.2.1 Pipe delivery, storage and sealing

#### Notes for installers



- Ensure that piping does not get bent or deformed during delivery or whilst stored.
- On construction sites store piping in a designated location.
- To prevent dust or moisture entering, piping should be kept sealed whilst in storage and until it is about to be connected. If piping is to be used soon, seal the openings with plugs or adhesive tape. If piping is to be stored for a long time, charge the piping with nitrogen at 0.2-0.5MPa and seal the openings by brazing.
- Storing piping directly on the ground risks dust or water ingress. Wooden supports can be used to raise piping off the ground.
- During installation, ensure that piping to be inserted through a hole in a wall is sealed to ensure dust and/or fragments of wall do not enter.
- Be sure to seal piping being installed outdoors (especially if being installed vertically) to prevent rain entering.

## 5.3 Manipulating Copper Piping

### 5.3.1 De-oiling

#### Notes for installers



- Lubrication oil used during some copper pipe manufacturing processes can cause deposits to form in R410A refrigerant systems, causing system errors. Oil-free copper piping should therefore be selected. If ordinary (oily) copper piping is used, it must be cleaned with gauze dipped in tetrachloroethylene solution prior to installation.

#### Caution

- Never use carbon tetrachloride (CCl<sub>4</sub>) for pipe cleansing or flushing, as doing so will seriously damage the system.

### 5.3.2 Cutting copper piping and removing burrs

#### Notes for installers



- Use a pipe cutter rather than a saw or cutting machine to cut piping. Rotate the piping evenly and slowly, applying even force to ensure that the piping does not become deformed during cutting. Using a saw or cutting machine to cut piping runs the risk of copper shavings entering the piping. Copper shavings are difficult to remove and pose a serious risk to the system if they enter the compressor or block the throttling unit.
- After cutting using a pipe cutter, use a reamer/scrapper to remove any burrs that have formed at the opening, keeping the opening of the piping downwards to avoid copper shavings from entering the piping.
- Remove burrs carefully to avoid scratches, which may prevent a proper seal being formed and lead to refrigerant leakage.



## 5.3.3 Expanding copper piping ends

### Notes for installers



- Ends of copper piping can be expanded so that another length of piping can be inserted and the joint brazed.
- Insert the expanding head of the pipe expander into the pipe. After completing pipe expansion, rotate the copper pipe a few degrees to rectify the straight line mark left by the expanding head.

### Caution

- Ensure that the expanded section of piping is smooth and even. Remove any burrs that remain after cutting.

Figure 3-5.1: Expanding copper piping ends

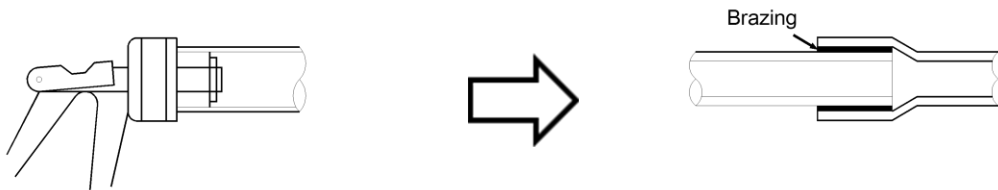

## 5.3.4 Flared joints

Flared joints should be used where a screw thread connection is required.

### Notes for installers



- Before flaring 1/2H (half hard) piping, anneal the end of the pipe to be flared.
- Remember to place the flare nut on the piping before flaring.
- Ensure the flared opening is not cracked, deformed or scratched, otherwise it will not form a good seal and refrigerant leakage may occur.
- The diameter of the flared opening should be within the ranges specified in Table 3-5.1. Refer to Figure 3-5.2.

Table 3-5.1: Flared opening size ranges

Pipe (mm)	Flared opening diameter (A) (mm)
Φ6.35	8.7 - 9.1
Φ9.53	12.8 - 13.2
Φ12.7	16.2 - 16.6
Φ15.9	19.3 - 19.7
Φ19.1	23.6 - 24.0

Figure 3-5.2: Flared opening

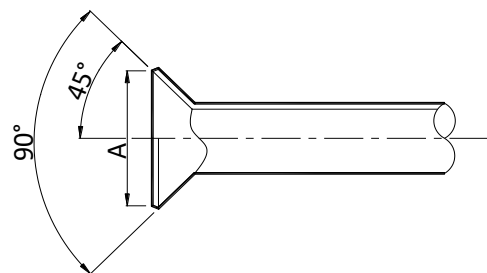

- When connecting a flared joint, apply some compressor oil to the inner and outer surfaces of the flared opening to facilitate the connection and rotation of the flare nut, ensure firm connection between the sealing surface and the bearing surface, and avoid the pipe becoming deformed.

### 5.3.5 Bending piping

Bending copper piping reduces the number of brazed joints required and can improve quality and save material.

#### Notes for installers



##### Piping bending methods

- Hand bending is suitable for thin copper piping ( $\Phi 6.35\text{mm} - \Phi 12.7\text{mm}$ ).
- Mechanical bending (using a bending spring, manual bending machine or powered bending machine) is suitable for a wide range of diameters ( $\Phi 6.35\text{mm} - \Phi 54.0\text{mm}$ ).

##### Caution

- When using a spring bender, ensure that the bender is clean before inserting it in the piping.
- After bending a copper pipe, ensure that there are no wrinkles or deformation on either side of the pipe.
- Ensure that bend angles do not exceed  $90^\circ$ , otherwise wrinkles may appear on the inner side of the pipe, and the pipe may buckle or crack. Refer to Figure 3-5.3.
- Do not use a pipe that has buckled during the bending process; ensure that the cross section at the bend is greater than  $2/3$  of the original area.

Figure 3-5.3: Pipe bending in excess of  $90^\circ$

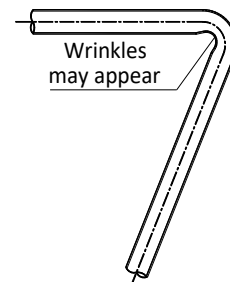

### 5.4 Refrigerant Piping Supports

When the air conditioning is running, the refrigerant piping will deform (shrink, expand, droop). To avoid damage to piping, hangers or supports should be spaced as per the criteria in the Table 3-5.2. In general, the gas and liquid pipes should be suspended in parallel and the interval between support points should be selected according to the diameter of the gas pipe.

Table 3-5.2: Refrigerant piping support spacings

Pipe (mm)	Interval between support points (m)	
	Horizontal Piping	Vertical Piping
$< \Phi 20$	1	1.5
$\Phi 20 - \Phi 40$	1.5	2
$> \Phi 40$	2	2.5

Suitable insulation should be provided between the piping and the supports. If wooden dowels or blocks are to be used, use wood that has undergone preservative treatment.

Changes in refrigerant flow direction and refrigerant temperature result in movement, expansion and shrinkage of the refrigerant piping. Piping should therefore not be fixed too tightly, otherwise stress concentrations may occur in the piping, with the potential for rupturing.

## 5.5 Brazing

Care must be taken to prevent oxide forming on the inside of copper piping during brazing. The presence of oxide in a refrigerant system adversely affects the operation of valves and compressors, potentially leading to low efficiency or even compressor failure. To prevent oxidation, during brazing nitrogen should be flowed through the refrigerant piping.

### Notes for installers



#### Warning

- Never flow oxygen through piping as doing so aids oxidation and could easily lead to explosion and as such is extremely dangerous.
- Take appropriate safety precautions such as having a fire extinguisher to hand whilst brazing.

#### Flowing nitrogen during brazing

- Use a pressure reducing valve to flow nitrogen through copper piping at 0.02-0.03MPa during brazing.
- Start the flow before brazing starts and ensure that the nitrogen continuously passes through the section being brazed until the brazing is complete and the copper has cooled down completely.

Figure 3-5.4: Flowing nitrogen through piping during brazing

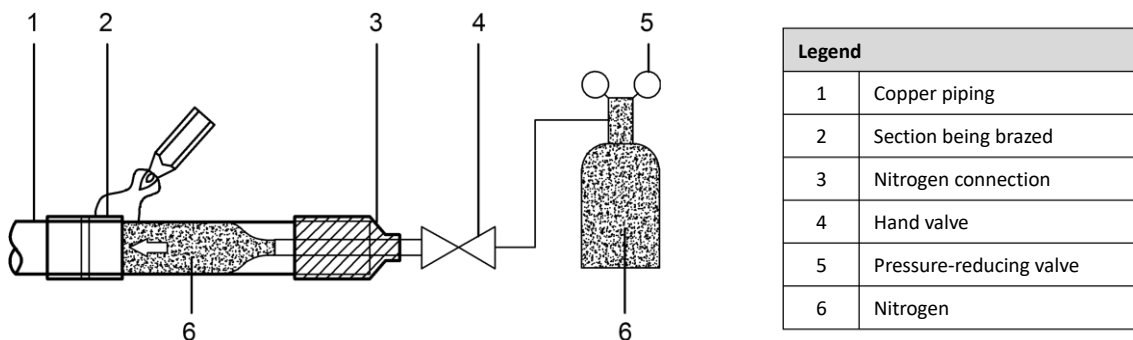

- When joining a shorter section of piping to a longer section, flow nitrogen from the shorter side to allow better displacement of air with nitrogen.
- If the distance from the point where nitrogen enters the piping to the joint to be brazed is long, ensure that the nitrogen is flowed for sufficient time to discharge all the air from the section to be brazed before commencing brazing.

Figure 3-5.5: Flowing nitrogen from shorter side during brazing

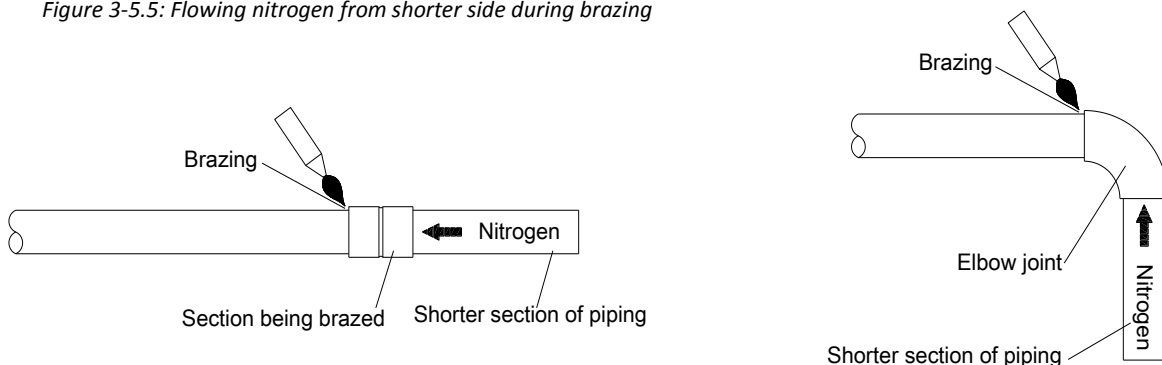

Box continued on next page ...

... box continued from previous page

**Piping orientation during brazing**

Brazing should be conducted downwards or horizontally to avoid filler leakage.

Figure 3-5.6: Piping orientation during brazing

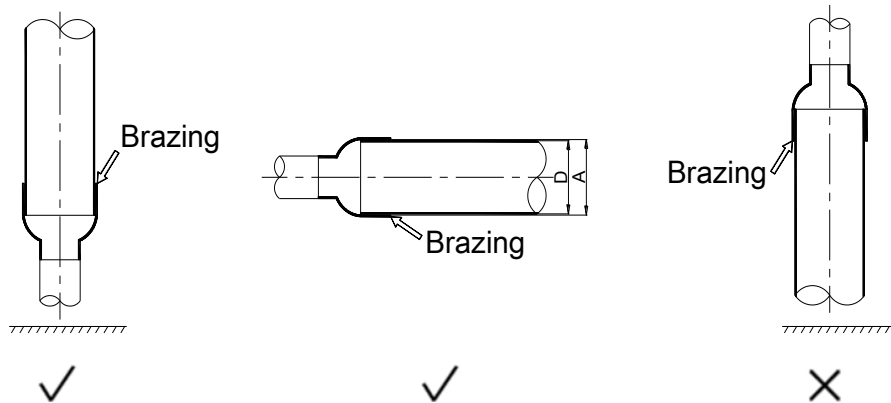

**Piping overlap during brazing**

Table 3-5.3 specifies the minimum permissible piping overlap and the range of permissible gap sizes for brazed joints on piping of different diameters. Refer also to Figure 3-5.7.

Figure 3-5.7: Piping overlap and gap for brazed joints

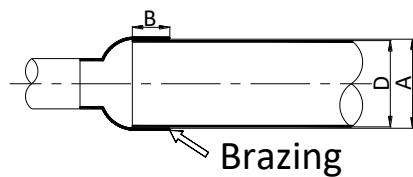

Legend	
A	Inner diameter of larger pipe
D	Outer diameter of smaller pipe
B	Inlaid depth (overlap)

Table 3-5.3: Piping overlap and gap for brazed joints<sup>1</sup>

D (mm)	Minimum permissible B (mm)	Permissible A – D (mm)
5 < D < 8	6	0.05 - 0.21
8 < D < 12	7	
12 < D < 16	8	0.05 - 0.27
16 < D < 25	10	
25 < D < 35	12	0.05 - 0.35
35 < D < 45	14	

Notes:

1. A, B, D refer to the dimensions shown in Figure 3-5.7.

**Filler**

- Use a copper/phosphorus brazing alloy (BCuP) filler that does not require flux.
- Do not use flux. Flux can cause corrosion of piping and can affect the performance of compressor oil.
- Do not use anti-oxidants when brazing. Residue can clog piping and damage components.

## 5.6 Branch Joints

### Notes for installers



- Use U-shaped branch joints as specified on the construction drawings – do not replace U-shaped branch joints with tee joints.
- To avoid accumulation of oil in the outdoor units, outdoor branch joints should be installed horizontally and must not be higher than the outdoor unit refrigerant outlets. Refer to Figure 3-5.9.
- Indoor branch joints may be installed either horizontally or vertically. Horizontal branch joints must be installed at an angle to the horizontal not exceeding 10° in order to avoid uneven distribution of refrigerant and possible malfunction. Refer to Figure 3-5.8.

Figure 3-5.8: Branch joint orientation

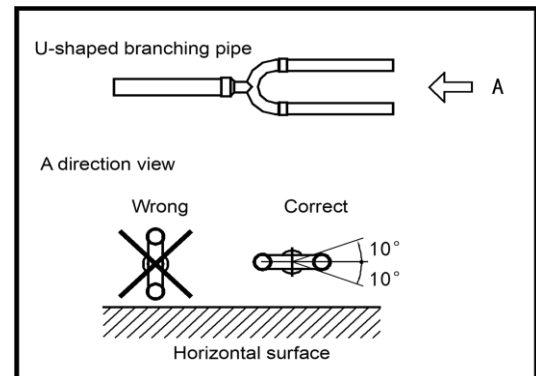
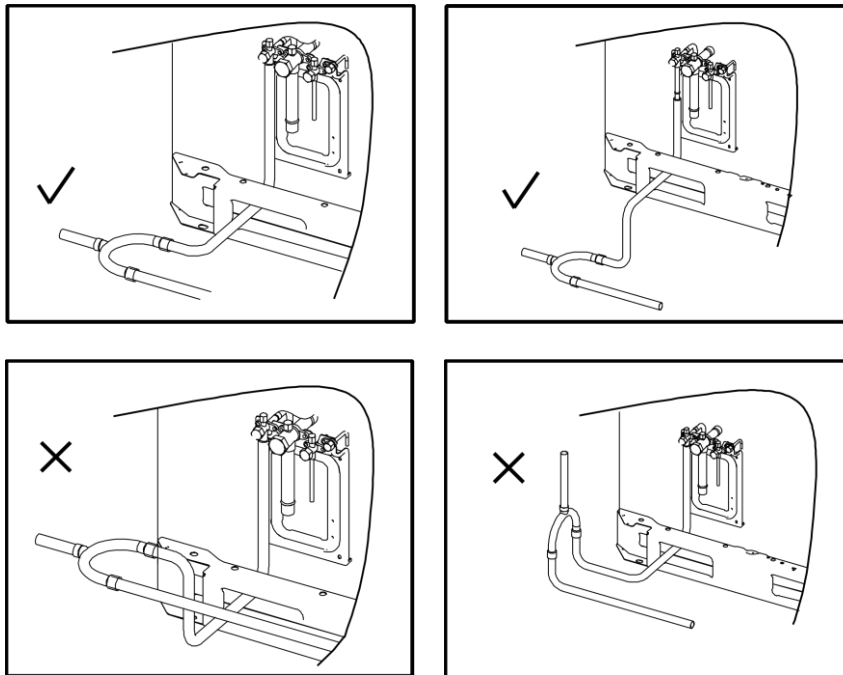

Figure 3-5.9: Installation of outdoor branch joints



- To ensure even distribution of refrigerant, a limitation is placed on how close branch joints may be installed to bends, other branch joints and the straight sections of piping leading to indoor units. Refer to Part 3, 4.6 “Branch Joints”.

## 5.7 Piping Connections Between Outdoor Units

The piping connecting the outdoor units should be horizontal and must not be higher than the refrigerant outlets. If necessary, to avoid obstacles the piping may be vertically offset below the outlets. When inserting a vertical offset to avoid an obstacle, the whole outdoor piping should be offset, rather than just the section adjacent to the obstacle. Refer to Figure 3-5.10.

Figure 3-5.10: Piping connections between outdoor units

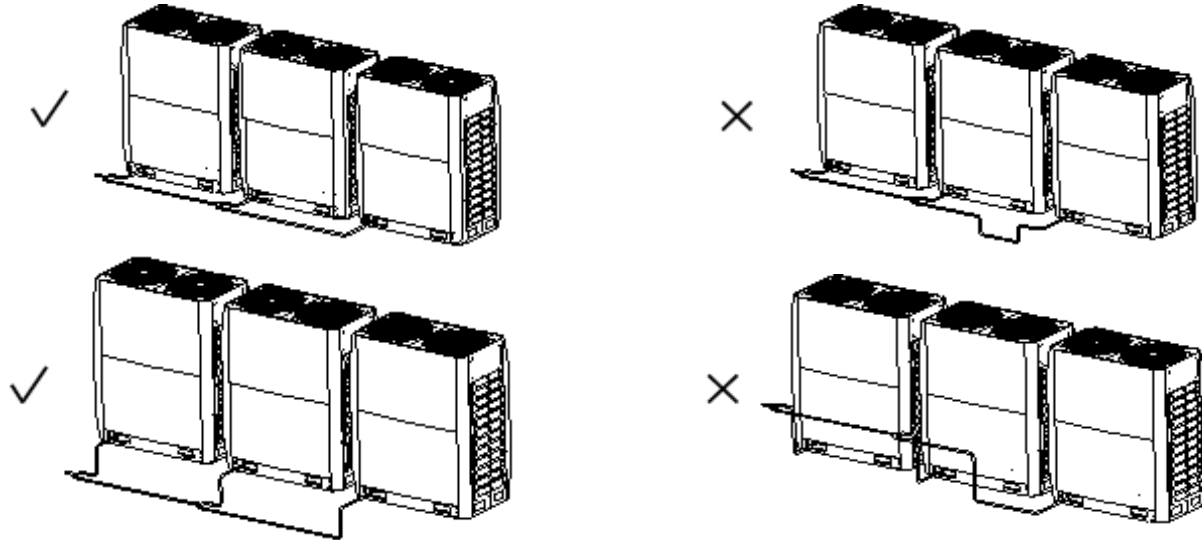

Outdoor piping should be installed in a metal casing to protect against exposure to sunlight, rain, wind and other potential causes of damage.

## 5.8 Pipe Flushing

### 5.8.1 Purpose

To remove dust, other particles and moisture, which could cause compressor malfunction if not flushed out before the system is run, the refrigerant piping should be flushed using nitrogen. As described in Part 3, 5.1.1 "Installation procedure", pipe flushing should be performed once the piping connections have been completed with the exception of the final connections to the indoor units. That is, flushing should be performed once the outdoor units have been connected but before the indoor units are connected.

### Notes for installers



#### Warning

Only use nitrogen for flushing. Using carbon dioxide risks leaving condensation in the piping. Oxygen, air, refrigerant, flammable gases and toxic gases must not be used for flushing. Use of such gases may result in fire or explosion.

#### Procedure

The liquid and gas sides can be flushed simultaneously; alternatively, one side can be flushed first and then Steps 1 to 8 repeated, for the other side. The flushing procedure is as follows:

1. Cover the inlets and outlets of the indoor units to prevent dirt getting blown in during pipe flushing. (Pipe flushing should be carried out before connecting the indoor units to the piping system.)
2. Attach a pressure reducing valve to a nitrogen cylinder.
3. Connect the pressure reducing valve outlet to the inlet on the liquid (or gas) side of the outdoor unit.
4. Use blind plugs to block all liquid (gas) side openings, except for the opening at the indoor unit which is furthest from the outdoor units ("Indoor unit A" in Figure 3-5.11).
5. Start to open the nitrogen cylinder valve and gradually increase the pressure to 0.5MPa.
6. Allow time for nitrogen to flow as far as the opening at indoor unit A.
7. Flush the first opening:
  - a) Using suitable material, such as a bag or cloth, press firmly against the opening at indoor unit A.
  - b) When the pressure becomes too high to block with your hand, suddenly remove your hand allowing gas to rush out.
  - c) Repeatedly flush in this manner until no further dirt or moisture is emitted from the piping. Use a clean cloth to check for dirt or moisture being emitted. Seal the opening once it has been flushed.
8. Flush the other openings in the same manner, working in sequence from indoor unit A towards the outdoor units. Refer to Figure 3-5.12.
9. Once flushing is complete, seal all openings to prevent dust and moisture from entering.

Figure 3-5.11: Pipe flushing using nitrogen

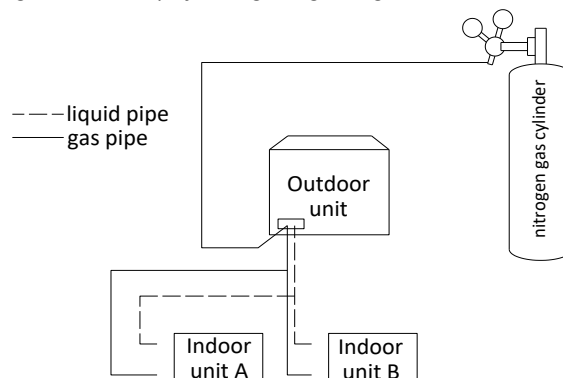
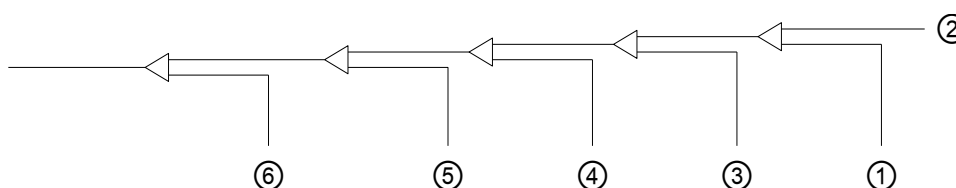

Figure 3-5.12: Pipe flushing sequence<sup>1</sup>



Notes:

1. 1-2-3-4-5-6 working towards the outdoor units.

## 5.9 Gastightness Test

### 5.9.1 Purpose

To prevent faults caused by refrigerant leakage, a gastightness test should be performed before system commissioning..

### 5.9.2 Procedure

#### Notes for installers



#### Warning

Only dry nitrogen should be used for gastightness testing. Oxygen, air, flammable gases and toxic gases must not be used for gastightness testing. Use of such gases may result in fire or explosion.

#### Procedure

The gastightness test procedure is as follows:

##### Step 1

- Once the piping system is complete and the indoor and outdoor units have been connected, vacuum the piping to -0.1MPa.

##### Step 2

- Charge the indoor piping with nitrogen at 0.3MPa through the needle valves on the liquid and gas stop valves and leave for at least 3 minutes (do not open the liquid or gas stop valves). Observe the pressure gauge to check for large leakages. If there is a large leakage, the pressure gauge will drop quickly.
- If there are no large leakages, charge the piping with nitrogen at 1.5MPa and leave for at least 3 minutes. Observe the pressure gauge to check for small leakages. If there is a small leakage, the pressure gauge will drop distinctly.
- If there are no small leakages, charge the piping with nitrogen at 4MPa and leave for at least 24 hours to check for micro leakages. Micro leakages are difficult to detect. To check for micro leakages, allow for any change in ambient temperature over the test period by adjusting the reference pressure by 0.01MPa per 1°C of temperature difference. Adjusted reference pressure = Pressure at pressurization + (temperature at observation – temperature at pressurization) × 0.01MPa. Compare the observed pressure with the adjusted reference pressure. If they are the same, the piping has passed the gastightness test. If the observed pressure is lower than the adjusted reference pressure, the piping has a micro leakage.
- If the leakage is detected, refer to Part 3, 5.9.3 “Leak detection”. Once the leak has been found and fixed, the gastightness test should be repeated.

##### Step 3

- If not continuing straight to vacuum drying (see Part 3, 5.10 “Vacuum Drying”) once the gastightness test is complete, reduce the system pressure to 0.5-0.8MPa and leave the system pressurized until ready to carry out the vacuum drying procedure.

Figure 3-5.13: Gastightness test

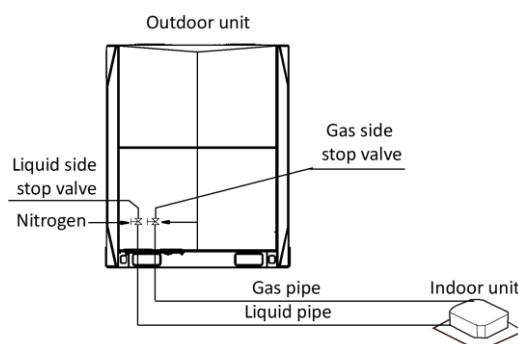



### 5.9.3 Leak detection

#### Notes for installers



The general methods for identifying the source of a leak are as follows:

1. Audio detection: relatively large leaks are audible.
2. Touch detection: place your hand at joints to feel for escaping gas.
3. Soapy water detection: small leaks can be detected by the formation of bubbles when soapy water is applied to a joint.
4. Refrigerant leak detection: for leaks that are difficult to detect, refrigerant leak detection may be used as follows:
  - a) Pressurize the piping with nitrogen at 0.3MPa.
  - b) Add refrigerant into the piping until the pressure reaches 0.5MPa.
  - c) Use a halogen refrigerant detector to find the leak.
  - d) If the leak source cannot be found, continuing charging with refrigerant to a pressure of 4MPa and then search again.

## 5.10 Vacuum Drying

### 5.10.1 Purpose

Vacuum drying should be performed in order to remove moisture and non-condensable gases from the system. Removing moisture prevents ice formation and oxidization of copper piping or other internal components. The presence of ice particles in the system would cause abnormal operation, whilst particles of oxidized copper can cause compressor damage. The presence of non-condensable gases in the system would lead to pressure fluctuations and poor heat exchange performance.

Vacuum drying also provides additional leak detection (in addition to the gastightness test).

5.10.2 Procedure

Notes for installers



During vacuum drying, a vacuum pump is used to lower the pressure in the piping to the extent that any moisture present evaporates. At 5mmHg (755mmHg below typical atmospheric pressure) the boiling point of water is 0°C. Therefore a vacuum pump capable of maintaining a pressure of -756mmHg or lower should be used. Using a vacuum pump with a discharge in excess of 4L/s and a precision level of 0.02mmHg is recommended.

Caution

- Before performing vacuum drying, make sure that all the outdoor unit stop valves are firmly closed.
- Once the vacuum drying is complete and the vacuum pump is stopped, the low pressure in the piping could suck vacuum pump lubricant into the air conditioning system. The same could happen if the vacuum pump stops unexpectedly during the vacuum drying procedure. Mixing of pump lubricant with compressor oil could cause compressor malfunction and a one-way valve should therefore be used to prevent vacuum pump lubricant seeping into the piping system.

Procedure

The vacuum drying procedure is as follows:

Step 1

- Connect the blue (low pressure side) hose of a pressure gauge to the master unit gas pipe stop valve, the red (high pressure side) hose to the master unit liquid pipe stop valve and the yellow hose to the vacuum pump.

Step 2

- Start the vacuum pump and then open the pressure gauge valves to start vacuum the system.
- After 30 minutes, close the pressure gauge valves.
- After a further 5 to 10 minutes check the pressure gauge. If the gauge has returned to zero, check for leakages in the refrigerant piping.

Step 3

- Re-open the pressure gauge valves and continue vacuum drying for at least 2 hours and until a pressure difference of 756mmHg or more has been achieved. Once the pressure difference of at least 756mmHg has been achieved, continue vacuum drying for 2 hours.

Step 4

- Close the pressure gauge valves and then stop the vacuum pump.
- After 1 hour, check the pressure gauge. If the pressure in the piping has not increased, the procedure is finished. If the pressure has increased, check for leakages.
- After vacuum drying, **keep the blue and red hoses connected to the pressure gauge and to the master unit stop valves**, in preparation for refrigerant charging (see Part 3, 8 “Charging Refrigerant”).

Figure 3-5.14: Vacuum drying

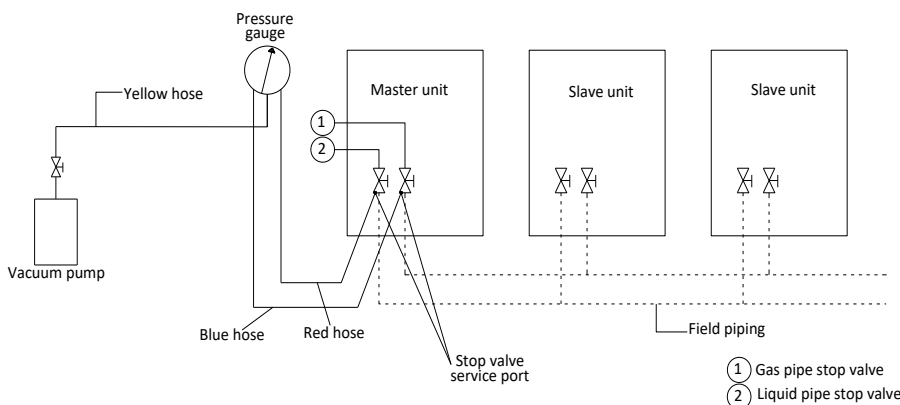

Pressure gauge

- ① Gas pipe stop valve
- ② Liquid pipe stop valve

## 6 Drain Piping

### 6.1 Design Considerations

Drain piping design should take account of the following considerations:

- Indoor unit condensate drain piping needs to be of sufficient diameter to carry the volume of condensate produced at the indoor units and installed at a slope sufficient to allow drainage. Discharge as close as possible to the indoor units is usually preferable.
- To prevent the drain piping becoming excessively long, consideration should be given to installing multiple drain piping systems, with each system having its own drainage point and providing drainage for a subset of the overall set of indoor units.
- The routing of drain piping should take into consideration the need to maintain sufficient slope for drainage whilst avoiding obstacles such as beams and ducting. The drain piping slope should be at least 1:100 away from indoor units. Refer to Figure 3-6.1.

Figure 3-6.1: Drain piping minimum slope requirement

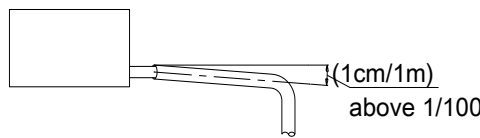

- To avoid backflow and other potential complications, two horizontal drain pipes should not meet at the same level. Refer to the Figure 3-6.2 for suitable connection arrangements. Such arrangements also allow the slope of the two horizontal pipes to be selected independently.

Figure 3-6.2: Drain piping joints – correct and incorrect configurations

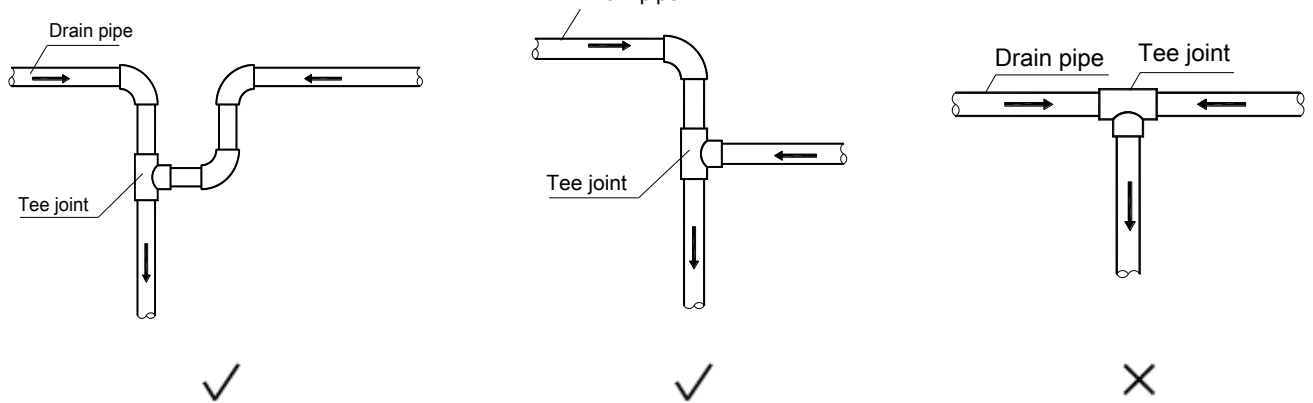

- Branch drain piping should join main drain piping from the top, as shown in Figure 3-6.3.
- Recommended support/hanger spacing is 0.8 – 1.0m for horizontal piping and 1.5 – 2.0m for vertical piping. Each vertical section should be fitted with at least two supports. For horizontal piping, spacings greater than those recommended leads to sagging and deformation of the pipe profile at the supports which impedes water flow and should therefore be avoided.
- Air vents should be fitted at the highest point of each drain piping system to ensure that condensation is discharged smoothly. U-bends or elbow joints should be used such that the vents face downwards, to prevent dust entering the piping. Refer to Figure 3-6.5. Air vents should not be installed too close to indoor unit lift pumps.

Figure 3-6.3: Branch drain piping joining main drain piping

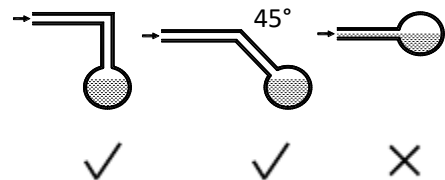

Figure 3-6.4: Effect of insufficient drain piping support

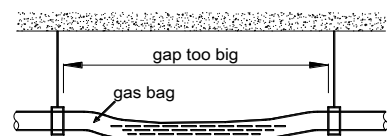
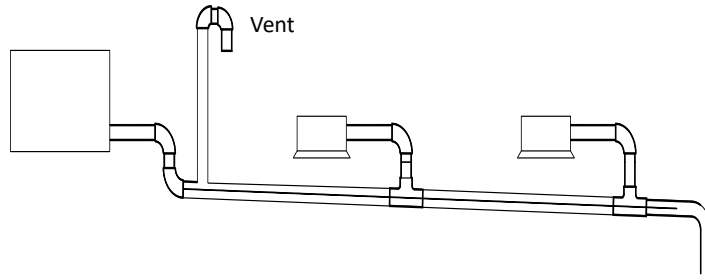

Figure 3-6.5: Drain piping air vents



- Air conditioner drain piping should be installed separately from waste, rainwater and other drain piping and should not come into direct contact with the ground.
- Drain piping diameter should be not less than the indoor units' drain piping connection.
- To allow inspection and maintenance, the piping clamps shipped with units should be used to attach drain piping to indoor units – adhesive should not be used.
- Thermal insulation should be added to drain piping to prevent condensation forming. Thermal insulation should extend all the way to the connection with the indoor unit.
- Units with drain pumps should have separate drain piping systems from systems that use natural drainage.

### 6.2 Water Traps

For indoor units with a high negative pressure differential at the outlet of the drainage pan, a trap should be fitted to the drain piping to prevent poor drainage and/or water being blown back into the drainage pan. Traps should be arranged as in Figure 3-6.6. The vertical separation H should be in excess of 50mm. A plug may be fitted to allow cleaning or inspection.

Figure 3-6.6: Drain piping water traps

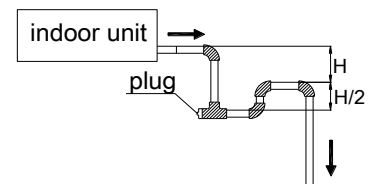

### 6.3 Selecting Piping Diameters

Select branch drainage piping (the drain piping connection to each unit) diameters according to indoor unit flow volume and select main drainage piping diameters according to the combined flow volume of the upstream indoor units. Use a design assumption of 2 liters of condensate per horsepower per hour. For example, the combined flow volume of three 2HP units and two 1.5HP units would be calculated as follows:

$$\begin{aligned} \text{Combined flow volume} &= 3 \times 2 \text{ L/HP/h} \times 2\text{HP} + 2 \times 2 \text{ L/HP/h} \times 1.5\text{HP} = 18 \text{ L/h} \end{aligned}$$

Tables 3-6.1 and 3-6.2 specify the required piping diameters for horizontal and vertical branch piping and for main piping. Note that main piping should use PVC40 or larger.

Table 3-6.1: Horizontal drain piping diameters

PVC piping	Nominal diameter (mm)	Capacity (L/h)		Remarks
		Slope 1:50	Slope 1:100	
PVC25	25	39	27	Branch piping only
PVC32	32	70	50	
PVC40	40	125	88	Branch or main piping
PVC50	50	247	175	
PVC63	63	473	334	

Table 3-6.2: Vertical drain piping diameters

PVC piping	Nominal diameter (mm)	Capacity (L/h)	Remarks
PVC25	25	220	Branch piping only
PVC32	32	410	
PVC40	40	730	Branch or main piping
PVC50	50	1440	
PVC63	63	2760	
PVC75	75	5710	
PVC90	90	8280	

## 6.4 Drain Piping for Units with Lift Pumps

Drain piping for units with lift pumps should take account of the following additional considerations:

- A downward sloping section should immediately follow the vertically rising section adjacent to the unit, otherwise a water pump error will occur. Refer to Figure 3-6.7.
- Air vents should not be installed on vertically rising sections of drain piping, otherwise water may be discharged through the air vent or water flow may be impeded.

Figure 3-6.7: Downward sloping section of drain piping

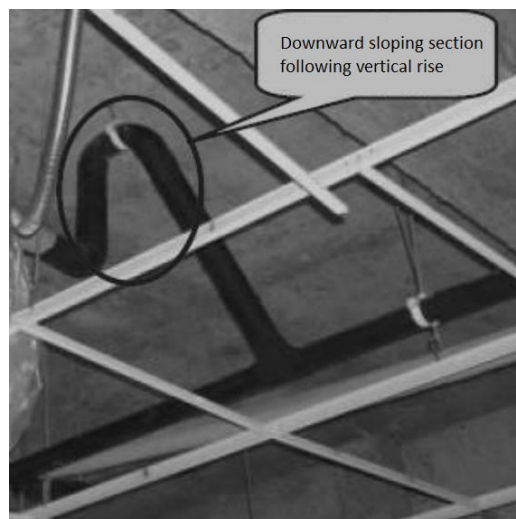

## 6.5 Drain Piping Installation

### Notes for installers



Installation of the drain piping should proceed in the following order:



### Caution

- Ensure that all joints are firm and once the drain piping is all connected conduct a watertightness test and water flow test.
- Do not connect air conditioner drain piping to waste, rainwater or other drain piping and do not let air conditioner drain piping come into direct contact with the ground.
- For units with drain pumps, test that the drain pump functions properly by adding water to the unit's drainage pan and running the unit. To allow inspection and maintenance, the pipe clamps shipped with units should be used to attach drain piping to indoor units – adhesive should not be used.

## 6.6 Watertightness Test and Water Flow Test

Once installation of a drainage piping system is complete, watertightness and water flow tests should be performed.

### Notes for installers



#### Watertightness test

- Fill the piping with water and test for leakages over a 24-hour period.

#### Water flow test (natural drainage test)

- Slowly fill the drainage pan of each indoor unit with at least 600ml of water through the inspection port and check that the water is discharged through the outlet of the drain piping.

#### Caution

- The drain plug in the drainage pan is for removing accumulated water prior to performing indoor unit maintenance. During normal operation, the drain should be plugged to prevent leakage.

## 7 Insulation

### 7.1 Refrigerant Piping Insulation

#### 7.1.1 Purpose

During operation, the temperature of the refrigerant piping varies. Insulation is required to ensure unit performance and compressor lifespan. During cooling, the gas pipe temperature can be very low. Insulation prevents condensation forming on the piping. During heating, the gas pipe temperature can rise to as high as 100°C. Insulation serves as necessary protection from burns.

#### 7.1.2 Selecting insulation materials

Refrigerant piping insulation should be closed-cell foam of B1 fire resistance rating that can withstand a constant temperature of over 120°C and that complies with all applicable legislation.

#### 7.1.3 Thickness of insulation

Minimum thicknesses for refrigerant piping insulation are specified in Table 3-7.1. In hot, humid environments, the thickness of insulation should be increased over and above the specifications in Table 3-7.1.

Table 3-7.1: Refrigerant piping insulation thickness

Pipe outer diameter (mm)	Minimum insulation thickness (mm)
Φ6.35	15
Φ9.53	
Φ12.7	
Φ15.9	20
Φ19.1	
Φ22.2	
Φ25.4	
Φ28.6	
Φ31.8	
Φ38.1	25
Φ41.3	
Φ44.5	
Φ54.0	

## VMEX VRF 460V 60Hz

### 7.1.4 Installation of piping insulation

With the exception of joint insulation, insulation should be applied to piping before fixing the piping in place. Insulation at joints in refrigerant piping should be applied after the gastightness test has been completed.

#### Notes for installers



- Installation of insulation should be carried out in a manner suited to the type of insulation material being used.
- Ensure there are no gaps at the joints between sections of insulation.
- Do not apply tape too tightly as doing so may shrink insulation, reducing its insulating properties leading to condensation and loss of efficiency.
- Insulate gas and liquid pipes separately, otherwise heat exchange between the two sides will greatly impact efficiency.
- Do not bind the separately insulated gas and liquid pipes together too tightly as doing so can damage the joints between sections of insulation.

### 7.1.5 Installation of joint insulation

Insulation at joints in the refrigerant piping should be installed after the gastightness test has been successfully completed. The procedure at each joint is as follows:

1. Cut a section of insulation 50 to 100mm longer than the gap to be filled. Ensure that the cross-sectional and longitudinal openings are all cut evenly.
2. Embed the section into the gap ensuring that the ends abut tightly to the sections of insulation either side of the gap.
3. Glue the longitudinal cut and the joints with the sections of insulation either side of the gap.
4. Seal the seams with tape.

Figure 3-7.1: Installation of joint insulation (unit: mm)

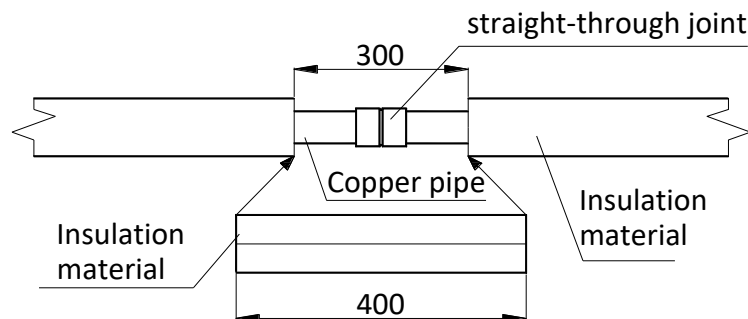

### 7.2 Drain Piping Insulation

- Use rubber/plastic insulating tube with a B1 fire resistance rating.
- The insulation should typically be in excess of 10mm thick.
- For drain piping installed inside a wall, insulation is not required.
- Use suitable adhesive to seal seams and joints in the insulation and then bind with cloth reinforced tape of width not less than 50mm. Ensure tape is fixed firmly to avoid condensation.
- Ensure the drain piping insulation adjacent to the indoor unit drainage water outlet is fixed to the unit itself using adhesive, to prevent condensation and dripping.

### 7.3 Ducting Insulation

- Suitable insulation should be added to ducting in according with all applicable legislation.

## 8 Charging Refrigerant

### 8.1 Calculating Additional Refrigerant Charge

The additional refrigerant charge required depends on the lengths and diameters of the outdoor and indoor liquid pipes. Table 3-8.1 shows the additional refrigerant charge required per meter of equivalent pipe length for different diameters of pipe. The total additional refrigerant charge is obtained by summing the additional charge requirements for each of the outdoor and indoor liquid pipes, as in the following formula, where L<sub>1</sub> to L<sub>8</sub> represent the equivalent lengths of the pipes of different diameters. Assume 0.5m for the equivalent pipe length of each branch joint.

$$\begin{aligned}
 \text{Additional refrigerant charge R (kg)} &= (L_1@Φ6.35) \times 0.022 \\
 &+ (L_2@Φ9.53) \times 0.057 \\
 &+ (L_3@Φ12.7) \times 0.110 \\
 &+ (L_4@Φ15.9) \times 0.170 \\
 &+ (L_5@Φ19.1) \times 0.260 \\
 &+ (L_6@Φ22.2) \times 0.360 \\
 &+ (L_7@Φ25.4) \times 0.520 \\
 &+ (L_8@Φ28.6) \times 0.680
 \end{aligned}$$

Table 3-8.1: Additional refrigerant charge

Liquid side piping (mm)	Additional refrigerant charge per meter of equivalent length of piping (kg)
Φ6.35	0.022
Φ9.53	0.057
Φ12.7	0.110
Φ15.9	0.170
Φ19.1	0.260
Φ22.2	0.360
Φ25.4	0.520
Φ28.6	0.680

### 8.2 Adding Refrigerant

#### Notes for installers



#### Caution

- Only charge refrigerant after performing a gastightness test and vacuum drying.
- Never charge more refrigerant than required as doing so can lead to liquid hammering.
- Only use refrigerant R410A - charging with an unsuitable substance may cause explosions or accidents.
- Use tools and equipment designed for use with R410A to ensure required pressure resistance and to prevent foreign materials from entering the system.
- Refrigerant must be treated in accordance with applicable legislation.
- Always use protective gloves and protect your eyes when charging refrigerant.
- Open refrigerant containers slowly.

#### Procedure

The procedure for adding refrigerant is as follows:

##### Step 1

- Calculate additional refrigerant charge R (kg) (see Part 3, 8.1 “Calculating Additional Refrigerant Charge”)

##### Step 2

- Place a tank of R410A refrigerant on a weighing scale. Turn the tank upside down to ensure refrigerant is charged in a liquid state. (R410A is a blend of two different chemicals compounds. Charging gaseous R410A into the system could mean that the refrigerant charged is not of the correct composition).
- After vacuum drying (see Part 3, 5.10 “Vacuum Drying”), the blue and red pressure gauge hoses should still be connected to the pressure gauge and to the master unit stop valves.
- Connect the yellow hose from the pressure gauge to the R410A refrigerant tank.

Box continued on next page ...



## Step 3

- Open the valve where the yellow hose meets the pressure gauge, and open the refrigerant tank slightly to let the refrigerant eliminate the air. Caution: open the tank slowly to avoid freezing your hand.
- Set the weighing scale to zero.

## Step 4

- Open the three valves on the pressure gauge to begin charging refrigerant.
- When the amount charged reaches R (kg), close the three valves. If the amount charged has not reached R (kg) but no additional refrigerant can be charged, close the three valves on the pressure gauge, run the outdoor units in cooling mode, and then open the yellow and blue valves. Continue charging until the full R (kg) of refrigerant has been charged, then close the yellow and blue valves. Note: Before running the system, be sure to complete all the pre-commissioning checks as listed in Part 3, 11.3 “Pre-commissioning Checks” and be sure to open all stop valves as running the system with the stop valves closed would damage the compressor.

Figure 3-8.1: Charging refrigerant

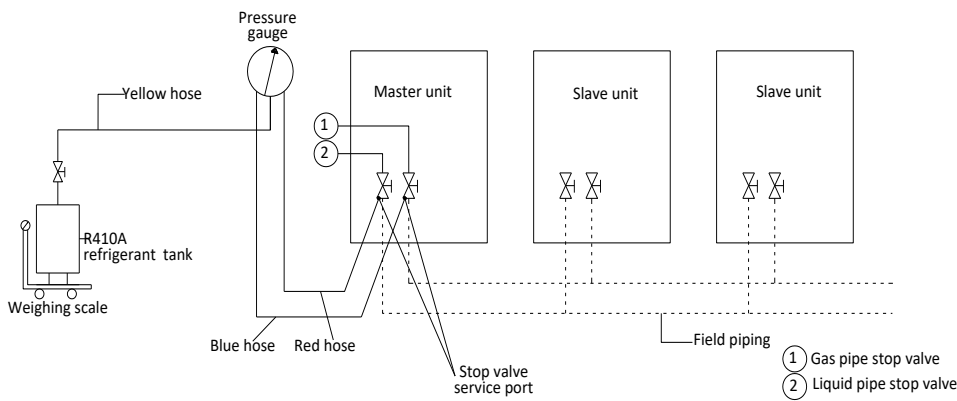

Pressure gauge

## 9 Electrical Wiring

### 9.1 General

#### Notes for installers



#### Caution

- All installation and wiring must be carried out by competent and suitably qualified, certified and accredited professionals and in accordance with all applicable legislation.
- Electrical systems should be grounded in accordance with all applicable legislation.
- Overcurrent circuit breakers and residual-current circuit breakers (ground fault circuit interrupters) should be used in accordance with all applicable legislation.
- Wiring patterns shown in this data book are general connection guides only and are not intended for, or to include all details for, any specific installation.
- The refrigerant piping, power wiring and communication wiring are typically run in parallel. However, the communication wiring should not be bound together with the refrigerant piping or power wiring. To prevent signal interference, the power wiring and communication wiring should not be run in the same conduit. If the power supply is less than 10A, a separation of at least 300mm between power wiring and communication wiring conduits should be maintained; if the power supply is in the range 10A to 50A then a separation of at least 500mm should be maintained.

### 9.2 Power Supply Wiring

Power supply wiring design and installation should adhere to the following requirements:

- Separate power supplies should be provided for the indoor units and outdoor units.
- Where five or more outdoor units are installed, additional residual current protection (leakage protection) should be installed as shown in Figure 3-9.1.
- All the indoor units in a system (i.e. all the indoor units connected to the same set of outdoor units) should be tied into the same power circuit with the same power supply, overcurrent and residual current protection (leakage protection) and manual switch, as shown in Figure 3-9.2. Do not install separate protectors or manual switches for each indoor unit. Powering on and shutting down all indoor units in a system should be done simultaneously. The reason for this is that if an indoor unit that is running were to suddenly power off whilst the other indoor units continued running, the evaporator of the powered-off unit would freeze since refrigerant would continue flowing to that unit (its expansion valve would still be open) but its fan would have stopped. The indoor units that remain running would not get sufficient refrigerant so their performance would suffer. Additionally, liquid refrigerant returning directly to the compressor from the powered-off unit would cause liquid hammering, potentially damaging the compressor.
- For outdoor unit power wire sizing and circuit breaker sizing, refer to Table 2-6.1 in Part 2, 6 “Electrical Characteristics”.

# VMEX VRF 460V 60Hz

Figure 3-9.1: Outdoor unit power supply wiring

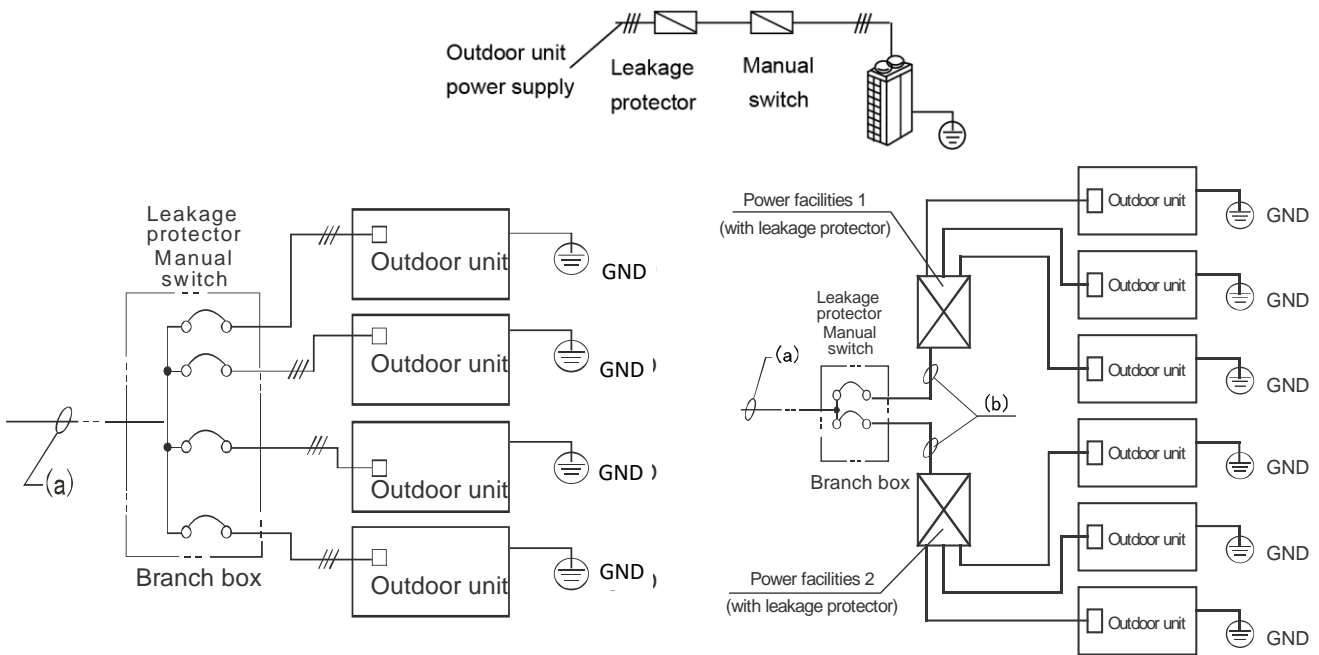
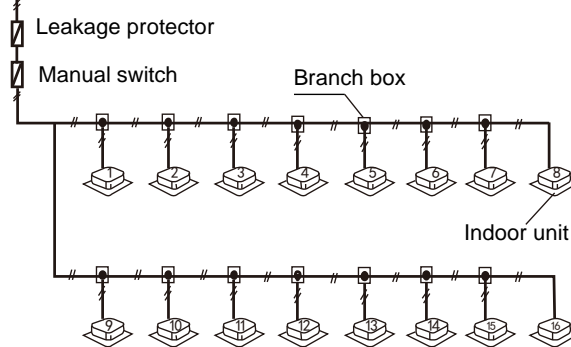

Figure 3-9.2: Indoor unit power supply wiring  
Single-phase 220V 50/60Hz



## Notes for installers



The 3-phase, 460V, 60Hz power supply should be connected to the outdoor unit power supply terminals as shown in Figure 3-9.3.

Figure 3-9.3: Outdoor unit 3-phase power supply terminals

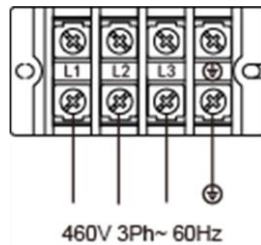

## 9.3 Communication Wiring

Communication wiring design and installation should adhere to the following requirements:

- 0.75mm<sup>2</sup> three-core shielded cable should be used for communication wiring. Using other types of cable can lead to interference and malfunction.

Indoor communication wiring:

- The P Q E communication wires should be connected one unit after another in a daisy chain from the outdoor unit to the final indoor unit as shown in Figure 3-9.4. At the final indoor unit, a 120Ω resistor should be connected between the P and Q terminals. After the final indoor unit, the communication wiring should NOT be continued back to the outdoor unit – that is, do not attempt to form a closed loop.
- The P and Q communication wires and should NOT be grounded.
- The shielding nets of the communication wires should be connected together and grounded. Grounding can be achieved by connecting to the metal casing adjacent to the P Q E terminals of the outdoor unit electrical control box.

Outdoor communication wiring:

- The H1 H2 E communication wires should be connected one unit after another in a daisy chain from the master outdoor unit to the final slave outdoor unit as shown in Figure 3-9.4.

Figure 3-9.4: Communication wiring configurations – correct and incorrect examples

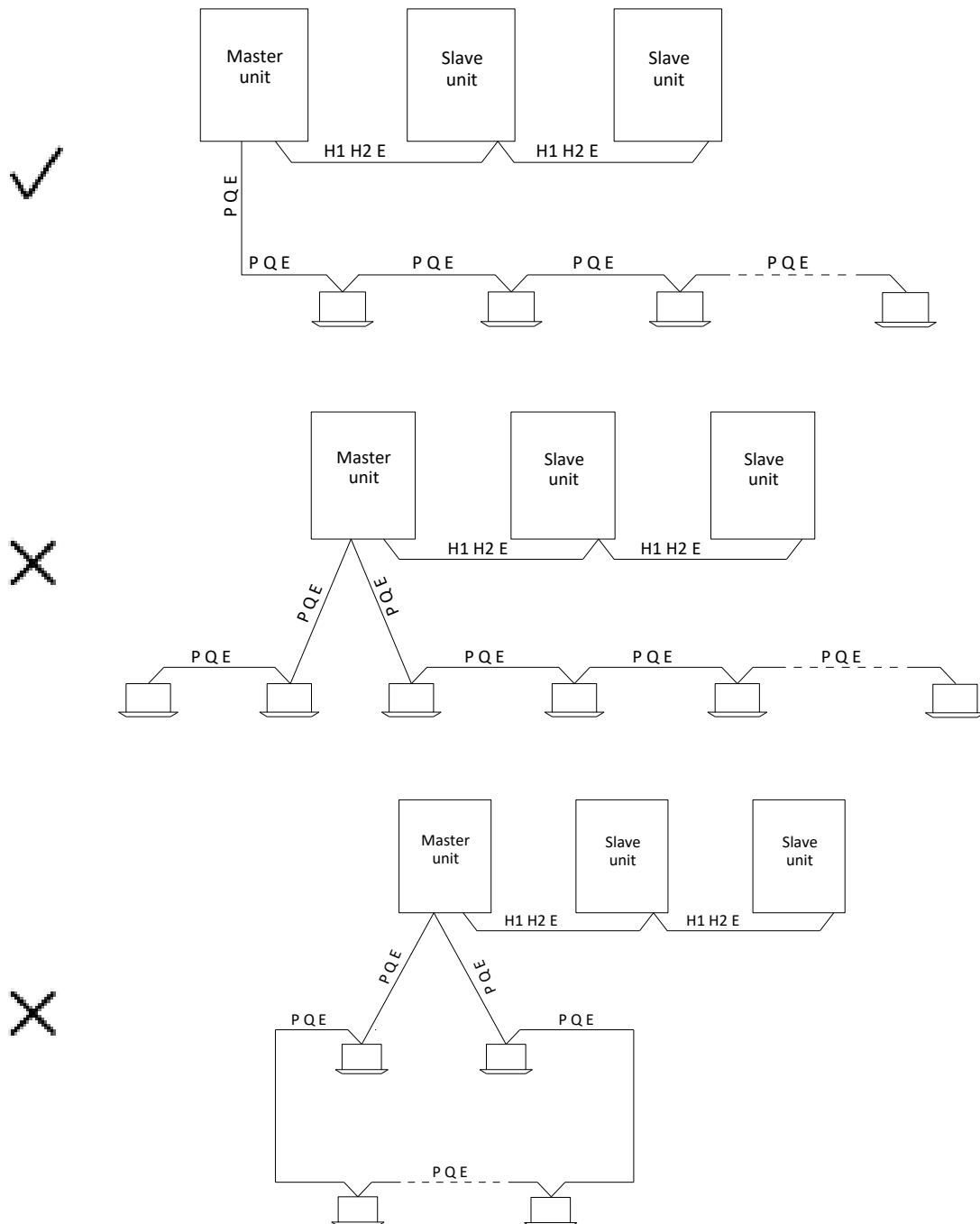

Notes for installers



The communication wires should be connected to the master outdoor unit terminals indicated in Figure 3-9.5 and Table 3-9.1.

**Caution**

- Communication wiring has polarity. Care should be taken to connect the poles correctly.

Figure 3-9.5: Master outdoor unit communication terminals

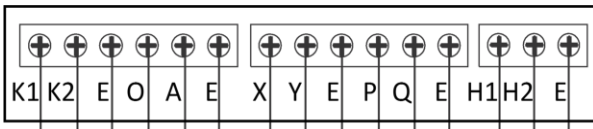
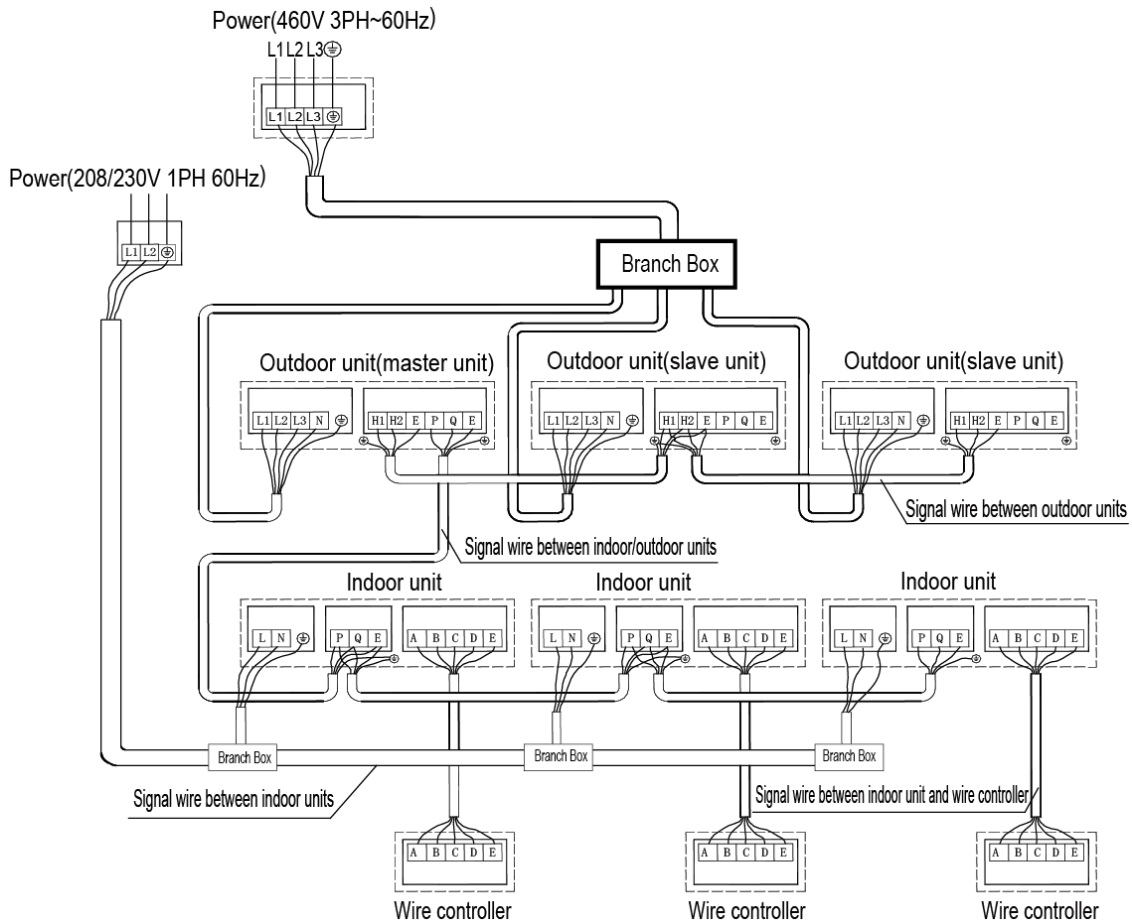

Table 3-9.1: Communication connections

Terminals	Connection
K1 K2 E	Connect to outdoor unit centralized monitor
O A E	Connect to digital energy meter
X Y E	Connect to indoor unit centralized controller
P Q E	Connect between indoor units and master outdoor unit
H1 H2 E	Connect between outdoor units

9.4 Wiring example

Figure 3-9.6: System power and communication wiring example



## 10 Installation in Areas of High Salinity

### 10.1 Caution

Do not install outdoor units where they could be directly exposed to sea air. Corrosion, particularly on the condenser and evaporator fins, could cause product malfunction or inefficient performance.

Outdoor units installed in seaside locations should be placed such as to avoid direct exposure to the sea air and additional anticorrosion treatment options should be selected, otherwise the service life of the outdoor units will be seriously affected.

Air conditioning installed in seaside locations should be run regularly as the running of the outdoor unit fans helps prevent build-up of salt on the outdoor unit heat exchangers.

### 10.2 Placement and Installation

Outdoor units should be installed 300m or more from the sea. If possible, well-ventilated indoor locations should be chosen. (When installing outdoor units indoors, outdoor unit discharge ducts should be added. See Part 3, 3 “Outdoor Unit Ducting and Shielding”.) Refer to Figure 3-10.1. If it is necessary to install outdoor units outside, direct exposure to the sea air should be avoided. A canopy should be added to shield the units from sea air and rain, as shown in Figure 3-10.2.

Ensure that base structures drain well so that outdoor unit footings do not become waterlogged. Check that outdoor unit casing drainage holes are not blocked.

Figure 3-10.1: Installation in a well-ventilated indoor area

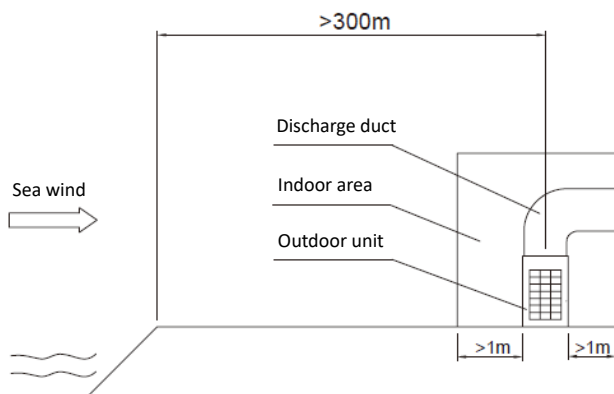
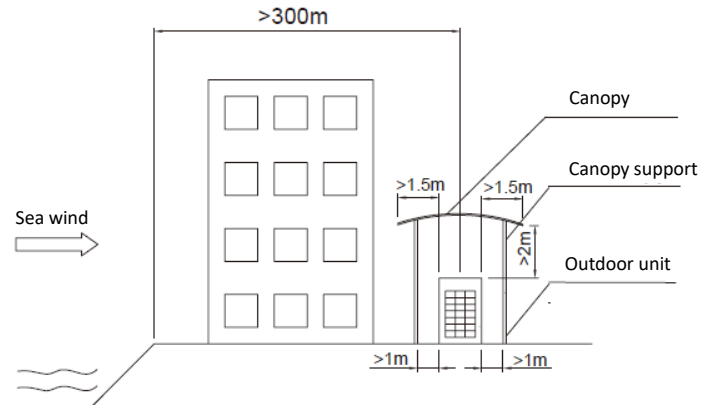

Figure 3-10.2: Installation outdoors under a canopy



### 10.3 Inspection and maintenance

In addition to standard outdoor unit servicing and maintenance, the following additional inspections and maintenance should be undertaken for outdoor units installed in seaside locations:

- A comprehensive post-installation inspection should check for any scratches or other damage to painted surfaces and any damaged areas should be repainted/repaired immediately.
- The units should be regularly cleaned using (non-salty) water to remove any salt that has accumulated. Areas cleaned should include the condenser, the refrigerant piping system, the outside surface of the unit casing and the outside surface of the electric control box.
- Regular inspections should check for corrosion and if necessary corroded components should be replaced and/or anti-corrosion treatments should be added.

## 11 Commissioning

### 11.1 Outdoor Unit Address and Capacity Settings

Before running a system for the first time, set each outdoor unit's address on switch ENC1 on each outdoor unit's main PCB. Refer to Table 3-11.1. The capacity of each outdoor unit (on switch ENC2 on each outdoor unit's main PCB) is factory-set and should not need changing. Check that the capacity settings are correct. Refer to Table 3-11.1.

Table 3-11.1: Outdoor unit address and capacity settings

Address settings		Capacity settings	
0	Master unit	0	8HP
1	Slave unit 1	1	10HP
2	Slave unit 2	2	12HP
3	Slave unit 3	3	14HP
≥4	Invalid	4	16HP
		5	18HP
		6	20HP
		7	22HP
		≥8	Invalid

### 11.2 Multi-system Projects

For projects with multiple refrigerant systems, each independent refrigeration system (i.e. each system of up to four outdoor units and their connected indoor units) should be given a test run independently, before the multiple systems that make up a project are run simultaneously.

### 11.3 Pre-commissioning Checks

Before turning on the power to the indoor and outdoor units, ensure the following:

1. All indoor and outdoor refrigeration piping and communication wiring has been connected to the correct refrigeration system and the system to which each indoor and outdoor unit belongs is clearly marked on each unit or recorded in some other suitable place.
2. Pipe flushing, gastightness testing and vacuum drying have been satisfactorily completed as per instructions.
3. All condensate drain piping is complete and a watertightness test has been satisfactorily completed.
4. All power and communication wiring is connected to the correct terminals on units and controllers. (Check that the different phases of the 3-phase power supplies have been connected to the correct terminals).
5. No wiring has been connected in a short-circuit.
6. The power supplies to indoor and outdoor units have been checked and the power supply voltages are within  $\pm 10\%$  of the rated voltages for each product.
7. All control wiring is 0.75mm<sup>2</sup> three-core shielded cable and the shielding has been grounded.
8. The outdoor units' address and capacity switches are set correctly (see Part 3, 11.1 "Outdoor Unit Address and Capacity Settings") and all other indoor and outdoor unit field settings have been set as required.
9. The additional refrigerant charge has been added as per Part 3, 8 "Charging Refrigerant". Note: In some circumstances it may be necessary to run the system in cooling mode during the refrigerant charging procedure. In such circumstances, points 1 to 8 above should be checked before running the system for the purpose of charging refrigerant and the outdoor unit liquid, gas and oil balance valves should be opened.

During commissioning, it is important that you:

- Keep a supply of R410A refrigerant at hand.
- Keep the system layout, system piping and control wiring diagrams at hand.

## 11.4 Commissioning Trial Runs

### 11.4.1 Commissioning test run of single refrigerant system

Once all the pre-commissioning checks in Part 3, 11.3 “Pre-commissioning Checks” have been completed, a test run should be performed as described below and a V5 X Series System Commissioning Report (see Part 3, 12 “Appendix to Part 3 – System Commissioning Report”) should be completed as a record of the operating status of the system during commissioning.

Note: When running the system for commissioning test runs, if the combination ratio is 100% or less, run all the indoor units and if the combination ratio is more than 100%, run indoor units with total capacity equal to the total capacity of the outdoor units.

The test run procedure is as follows:

1. Open the outdoor unit liquid, gas and oil balance valves.
2. Turn on the power to the outdoor units.
3. If manual addressing is being used, set the addresses of each indoor unit.
4. Leave the power on for a minimum of 12 hours prior to running the system to ensure that the crankcase heaters have heated the compressor oil sufficiently.
5. Run the system:
  - a) Run the system in cooling mode with the following settings: temperature 17°C ; fan speed high.
  - b) After one hour, complete Sheet A of the system commissioning report then check the system parameters using the SW2 system check button on each outdoor unit’s main PCB and complete the cooling mode columns of one Sheet D and one Sheet E of the system commissioning report for each outdoor unit.
  - c) Run the system in heating mode with the following settings: temperature 30°C ; fan speed high.
  - d) After one hour, complete Sheet B of the system commissioning report then check the system parameters using the SW2 system check button on each outdoor unit’s main PCB and complete the heating mode columns of one Sheet D and one Sheet E of the system commissioning report for each outdoor unit.
6. Finally, complete Sheet C of the system commissioning report.

### 11.4.2 Commissioning test run of multiple refrigerant systems

Once the commissioning test run of each refrigerant system has been satisfactorily completed as per Part 3, 11.4.1 “Commissioning test run of single refrigerant system”, run the multiple systems that make up a project simultaneously and check for any abnormalities.



### 12 Appendix to Part 3 – System Commissioning Report

A total of up to 11 report sheets should be completed for each system:

- One Sheet A, one Sheet B and one Sheet C per system.
- One Sheet D and one Sheet E per outdoor unit.

VMEX Series System Commissioning Report – Sheet A

SYSTEM INFORMATION			
Project name and location			Customer company
System name			Installation company
Commissioning date			Agent company
Outdoor ambient temp.			Commissioning engineer
Power supply (V)	A-B	B-C	C-A

OUTDOOR UNIT INFORMATION				
	Master unit	Slave unit 1	Slave unit 2	Slave unit 3
Model				
Serial no.				

	OUTDOOR UNITS												
	Master unit			Slave unit 1			Slave unit 2			Slave unit 3			
	Compressor suction pipe temperature												
	System pressure at check port												
	Phase currents (A)	A	B	C	A	B	C	A	B	C	A	B	C
Within normal range?													

COOLING MODE PARAMETER RECORD (After running in cooling mode for one hour)	INDOOR UNITS							
	(Sample of over 20% of the indoor units including the unit farthest from the outdoor units)							
	Room no.	Model	Address	Set temp. (°C)	Inlet temp. (°C)	Outlet temp. (°C)	Drainage OK?	Abnormal noise/vibration?

**VMEX Series System Commissioning Report – Sheet B**

Project name and location	System name
---------------------------	-------------

<b>HEATING MODE PARAMETER RECORD</b> (After running in heating mode for one hour)	<b>OUTDOOR UNITS</b>												
		Master unit			Slave unit 1			Slave unit 2			Slave unit 3		
	Compressor suction pipe temperature												
	System pressure at check port												
		A	B	C	A	B	C	A	B	C	A	B	C
	Phase currents (A)												
	Within normal range?												
	<b>INDOOR UNITS</b>												
	(Sample of over 20% of the indoor units including the unit farthest from the outdoor units)												
	Room no.	Model	Address	Set temp. (°C)	Inlet temp. (°C)	Outlet temp. (°C)	Drainage OK?	Abnormal noise/vibration?					

VMEX Series System Commissioning Report – Sheet C

Project name and location		System name	
---------------------------	--	-------------	--

RECORD OF ISSUES SEEN DURING COMMISSIONING				
No.	Description of observed issue	Suspected cause	Troubleshooting undertaken	Serial no. of relevant unit
1				
2				
3				

OUTDOOR UNIT FINAL CHECKLIST				
	Master unit	Slave unit 1	Slave unit 2	Slave unit 3
SW2 system check performed?				
Any abnormal noise?				
Any abnormal vibration?				
Fan rotation normal?				

	Commissioning engineer	Dealer	Midea representative
Name:			
Signature:			
Date:			

**VMEX Series System Commissioning Report – Sheet D**

<b>Project name and location</b>		<b>System name</b>	
----------------------------------	--	--------------------	--

DSP1 content	Parameters displayed on DSP2	Remarks	Observed values	
			Cooling mode	Heating mode
- 0	Outdoor unit address	Master unit: 0; slave units: 1, 2, 3		
- 1	Outdoor unit capacity	Refer to Note 1		
- 2	Number of outdoor units	Displayed on master unit PCB only		
- 3	Number of indoor units as set on PCB	Displayed on master unit PCB only		
- 4	Outdoor unit output metric (total of all units)	Displayed on master unit PCB only		
- 5	Indoor unit demand metric (total of all units)			
- 6	Outdoor unit output metric (master unit)			
- 7	Operating mode	Refer to Note 2		
- 8	Outdoor unit output metric (this unit)			
- 9	Fan A speed index	Refer to Note 3		
10	Fan B speed index	Refer to Note 3		
11	Average indoor heat exchanger pipe temperature (°C)	Actual value = value displayed		
12	Outdoor heat exchanger pipe temperature (°C)	Actual value = value displayed		
13	Outdoor ambient temperature (°C)	Actual value = value displayed		
14	Inverter compressor A discharge temperature (°C)	Actual value = value displayed		
15	Inverter compressor B discharge temperature (°C)	Actual value = value displayed		
16	Main inverter module temperature (°C)	Actual value = value displayed		
17	Saturation temperature (°C) corresponding to the discharge pressure	Actual value = value displayed - 30		
18	Inverter compressor A current (A)	Actual value = value displayed		
19	Inverter compressor B current (A)	Actual value = value displayed		
20	EXVA position	Steps = value displayed × 8		
21	EXVB position	Steps = value displayed × 8		

*Table continued on next page ...*

VMEX Series System Commissioning Report – Sheet E

Project name and location		System name	
---------------------------	--	-------------	--

... table continued from previous page

DSP1 content	Parameters displayed on DSP2	Remarks	Observed values	
			Cooling mode	Heating mode
22	Compressor discharge pressure (MPa)	Actual value = value displayed x 0.1		
23	Reserved			
24	Number of indoor units currently in communication with master unit	Actual value = value displayed		
25	Number of indoor units currently operating	Actual value = value displayed		
26	Priority mode	Refer to Note 4		
27	Silent mode	Refer to Note 5		
28	Static pressure mode	Refer to Note 6		
29	DC voltage A	Actual value = value displayed x 10		
30	DC voltage B	Actual value = value displayed x 10		
31	Reserved			
32	Most recent error or protection code	000 is displayed if no error or protection events have occurred since start-up		
33	Error clearance metric	Actual value = value displayed		
34	----	End		

Notes:

1. Outdoor unit capacity setting:
  - 0: 8HP; 1: 10HP; 2: 12HP; 3: 14HP; 4: 16HP; 5: 18HP; 6: 20HP; 7: 22HP.
2. Operating mode:
  - 0: off; 2: cooling; 3: heating; 4: forced cooling.
3. The fan speed index is related to the fan speed in rpm as described in the V5 X Service Manual, Part 3.
4. Priority mode:
  - 0: heating priority; 1: cooling priority; 2: VIP priority or voting priority; 3: heating only; 4: cooling only.
5. Silent mode:
  - 0: night silent mode; 1: silent mode; 2: super silent mode; 3: no silent mode.
6. Static pressure mode:
  - 0: standard static pressure; 1: low static pressure; 2: medium static pressure; 3: high static pressure.



**OMEGA**  
ENVIRONMENTAL  
TECHNOLOGIES LLC.

17702 Mitchell North, #101  
Irvine, CA. 92614 .USA  
Tel: 714 795 2830  
Fax: 714 966 1646  
info@omegavrf.com  
www.omegavrf.com

**OTEC**<sup>TM</sup>  
AIR CONDITIONING

**Showroom & Technology Center**  
11380 Interchange Circle North  
Miramar, FL 33025 .USA  
Tel: 305 901 1270  
Fax: 954 212 8280  
info@otecomega.com  
www.otecomega.com

VMEXQ8A-TM1D0123