

VECR Series

Round Flow Cassette Indoor Unit

Service Manual

220~240V/1/50-60Hz

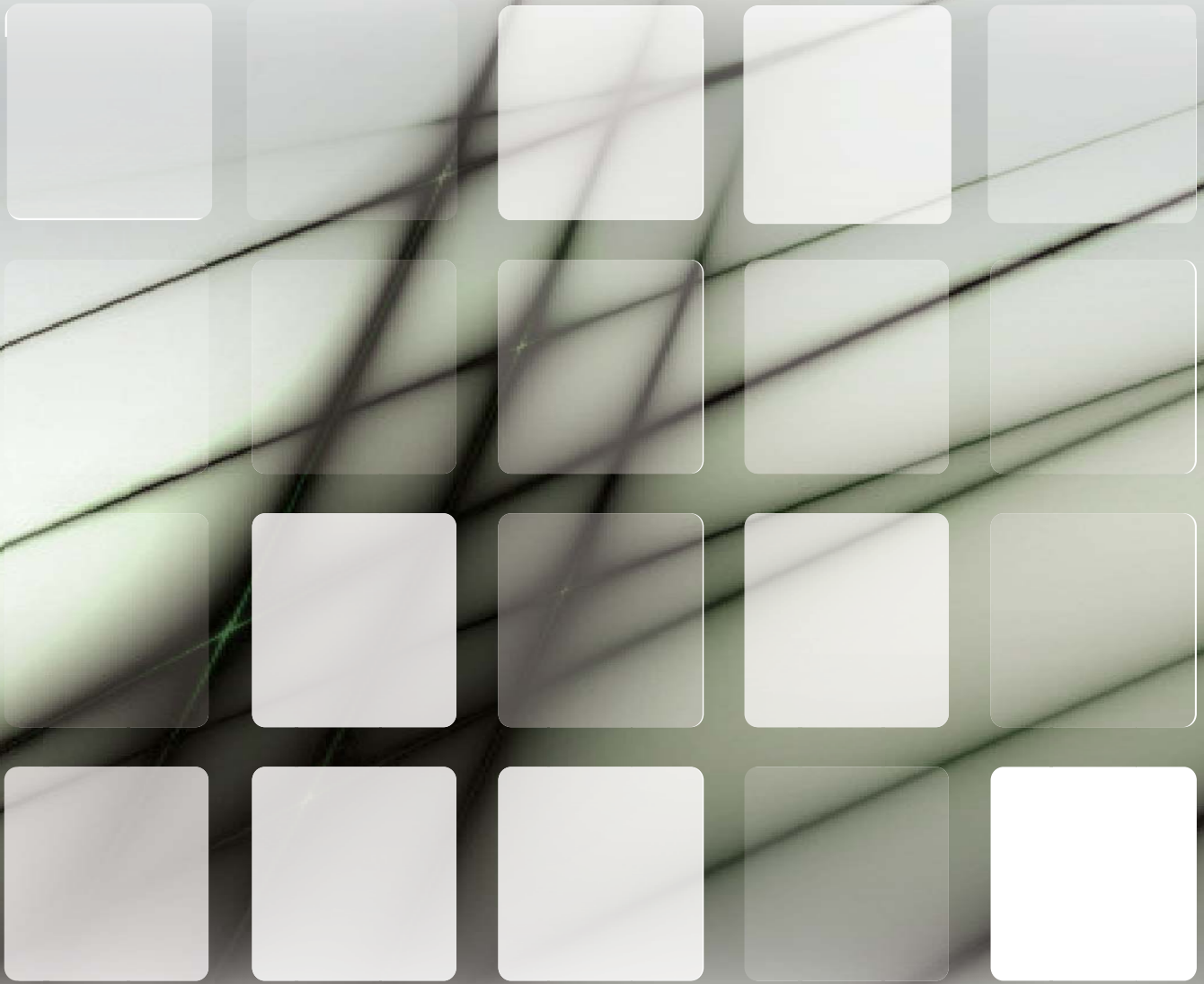

CONTENTS

1	Main PCB Ports	2
2	Indoor Unit Field Settings	5
3	Display Panels.....	10
4	Errors.....	14
5	Troubleshooting	16
6	Appendix.....	34

The 2nd Generation DC Series VRF Indoor Units

1 Main PCB Ports

1.1 Four-way Cassette

Figure 1.1: Four-way Cassette main PCB ports

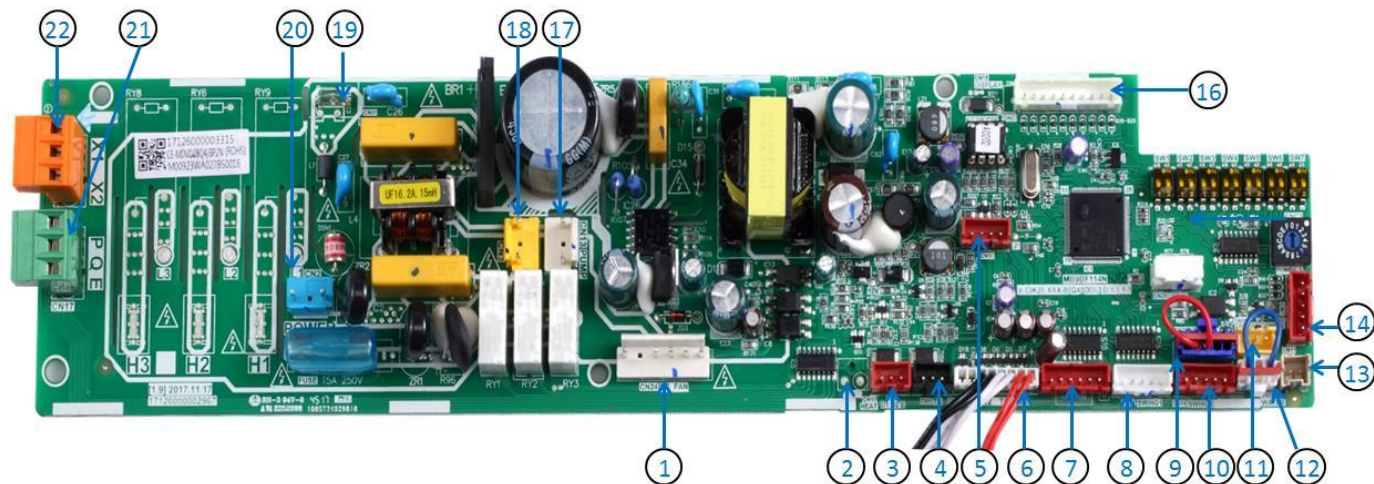

Table 1.1: Four-way Cassette main PCB ports

Label in Figure 1.1	Code	Content	Port voltage
1	CN24	Fan connection (fan control and power supply to fan motor)	White-black: 15V DC; Red-black: 310V DC
2	CN12	Reserved ¹	
3	CN9	D1 D2 E communication port	2.5-2.7V DC
4	CN6	Reserved ¹	
5	CN30	Reserved ¹	
6	CN4	Red: Indoor heat exchanger outlet temperature sensor connection; White: Indoor ambient temperature sensor connection; Black: Indoor heat exchanger mid-point temperature sensor connection;	5V DC
7	CN8	EEV drive port	12V DC
8	CN21	Vertical louver	12V DC
9	CN20	Net communication port	5V DC
10	CN14	Reserved ¹	
11	CN55	Remote on/off switch connection	12V DC
12	CN5	Water level switch connection	5V DC
13	CN11	Reserved ¹	
14	CN7	Reserved ¹	
15	CN25	Program update port	5V DC
16	CN15	Display panel connection	5V DC
17	CN13	Pump drive port	220V AC
18	CN3	Reserved ¹	
19	CN31	Ground port	
20	CN2	AC power input	220V AC
21	CN18	X1 X2 communication port	18V DC
22	CN17	P Q E communication port	2.5-2.7V DC

Notes:

1. The reserved ports may not be welded on the PCB.

The 2nd Generation DC Series VRF Indoor Units

1.12 Console Unit

Figure 1.13: Console Unit main PCB ports

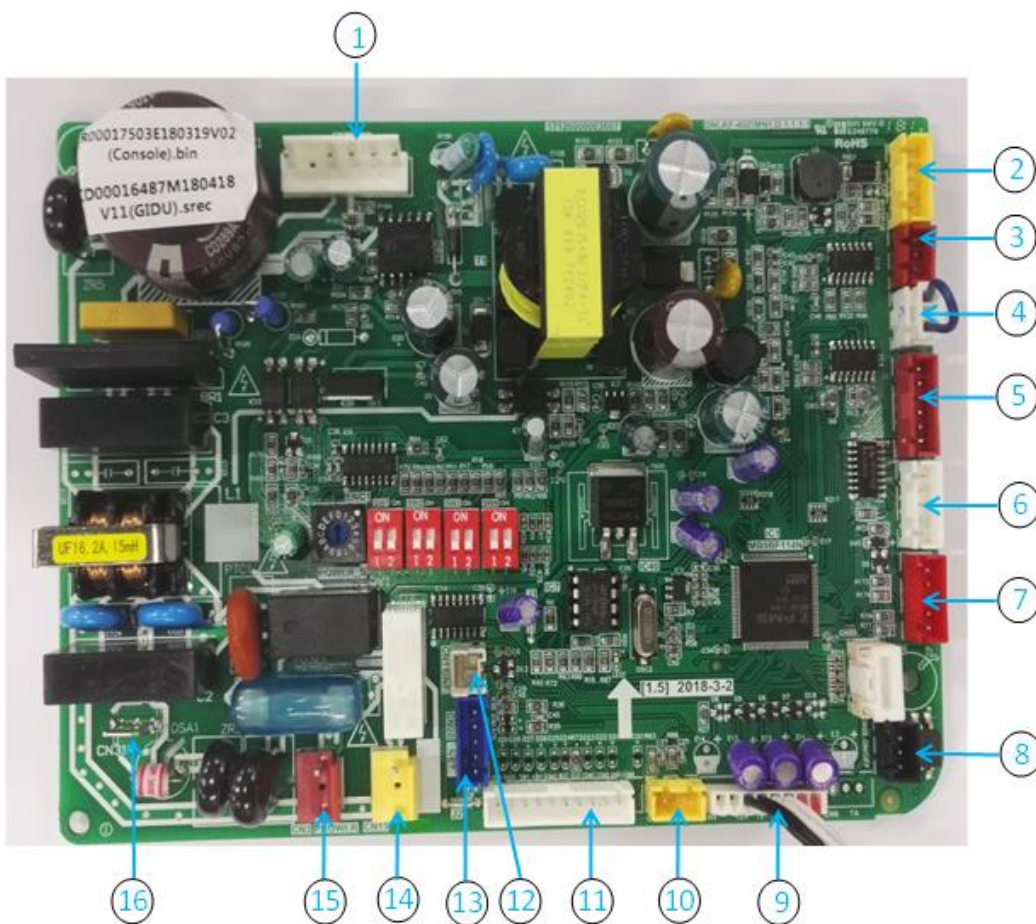

Table 1.13: Console unit main PCB ports

Label in Figure 1.13	Code	Content	Port voltage
1	CN24	Fan connection (fan control and power supply to fan motor)	White-black: 15V DC; Red-black: 310V DC
2	CN17	X1 X2 P Q E communication port	X1 X2:18V DC ; P Q E:2.5-2.7V DC
3	CN9	D1 D2 E communication port	2.5-2.7V DC
4	CN5	Water level switch connection	5V DC
5	CN8	EEV drive port	12V DC
6	CN14	Up air outlet Vertical louver	12V DC
7	CN21	Lower air outlet Vertical louver	12V DC
8	CN55	Remote on/off switch connection	12V DC
9	CN4	Red: Indoor heat exchanger outlet temperature sensor connection;	5V DC
		White: Indoor ambient temperature sensor connection;	
		Black: Indoor heat exchanger mid-point temperature sensor connection;	
10	CN36	switch board	5V DC
11	CN15	Display panel connection	5V DC
12	CN11	Reserved ¹	
13	CN20	Net communication port	5V DC

The 2nd Generation DC Series VRF Indoor Units

Table 1.13: Console unit main PCB ports

Label in Figure 1.13	Code	Content	Port voltage
11	CN1	AC power input	220V AC
12	CN2	Reserved ¹	
13	CN3	Pump drive port	220V AC
14	CN8	Ground port	
15	CN24	Fan connection (fan control and power supply to fan motor)	White-black: 15V DC; Red-black: 310V DC

Notes:

The reserved ports may not be weld on the PCB.

The 2nd Generation DC Series VRF Indoor Units

2 Indoor Unit Field Settings

2.1 PCB Switch and Jumper Settings

2.1.1 Four-way Cassette, Compact Four-way Cassette, One-way Cassette, Two-way Cassette, Floor Standing, Ceiling & Floor

Table 2.1: Four-way Cassette, Compact Four-way Cassette, One-way Cassette, Two-way Cassette, Floor Standing, Ceiling & Floor main PCB settings













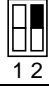







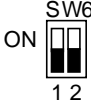

Switch	Setting	Switch positions ¹	Description
SW1_1	Cooling mode temperature compensation ²	ON 	Cooling mode temperature compensation is 0°C (default)
		ON 	Cooling mode temperature compensation is 2°C
SW1_2	EXV positions	ON 	EXV positions 96 (steps) in standby heating mode (default)
		ON 	EXV positions 72 (steps) in standby heating mode
SW2			Reserved
SW3_1	Addressing mode	ON 	Reserved (default)
		ON 	Clear indoor unit address
SW3_2			Reserved
SW4	Heating mode fan cycle	ON 	In heating mode when the set temperature has been reached, the fan operates in a 4 minutes off / 1 minute on repeating cycle (default)
		ON 	In heating mode when the set temperature has been reached, the fan operates in an 8 minutes off / 1 minute on repeating cycle
		ON 	In heating mode when the set temperature has been reached, the fan operates in a 12 minutes off / 1 minute on repeating cycle
		ON 	In heating mode when the set temperature has been reached, the fan operates in a 16 minutes off / 1 minute on repeating cycle
SW5	Cold draft prevention	ON 	In heating mode fan does not run when indoor heat exchanger mid-point temperature is 15°C or below (default)
		ON 	In heating mode fan does not run when indoor heat exchanger mid-point temperature is 20°C or below
		ON 	In heating mode fan does not run when indoor heat exchanger mid-point temperature is 24°C or below
		ON 	In heating mode fan does not run when indoor heat exchanger mid-point temperature is 26°C or below

Table continued on next page ...

The 2nd Generation DC Series VRF Indoor Units

Table 2.2: Four-way Cassette, Compact Four-way Cassette, One-way Cassette, Two-way Cassette, Floor Standing, Ceiling & Floor main PCB settings (continued)

Switch	Setting	Switch positions ¹	Description
SW6	Heating mode temperature compensation ³		Heating mode temperature compensation is 6°C (default)
			Heating mode temperature compensation is 2°C
			Heating mode temperature compensation is 4°C
			Heating mode temperature compensation is 0°C
SW7		Reserved	
J1	Auto restart ⁴		Auto restart function enabled (default)
			Auto restart function disabled
ENC1+SW7 ⁵	Indoor unit capacity ⁶	 ENC1 +  SW7	0: 1.8kW or 2.2kW; 1: 2.8kW; 2: 3.6kW; 3: 4.5kW; 4: 5.6kW; 5: 7.1kW; 6: 8.0kW; 7: 9.0kW; 8: 10.0kW; 9: 11.2kW; A: 12.5kW; B: 14.0kW; C: 16kW; D:18kW; E:20kW; F:25kW
ENC1+SW7	Indoor unit capacity	 ENC1 +  SW7	0: 28kW; 1: 33.5kW; 2: 40kW; 3: 45kW; 4: 56kW

Notes:

1. The black rectangles denote the switch positions.
2. Refer to 2.2.1 "Cooling mode temperature compensation setting".
3. Refer to 2.2.2 "Heating mode temperature compensation setting".
4. Refer to 2.2.3 "Auto restart setting".
5. For the indoor units not having switch SW7, just change the value on switch ENC1 to set the indoor unit capacity.
6. Switch ENC1 is factory-set and its setting should normally not be changed. The only circumstances in which a switch ENC1 might need to be set in the field is when replacing a main PCB. When replacing a main PCB, ensure that the capacity setting on switch ENC1 on the new PCB is consistent with the unit capacity given on the unit's nameplate.

The 2nd Generation DC Series VRF Indoor Units

2.1.5 Console unit

Table 2.5: Console unit main PCB settings















Switch	Setting	Switch positions ¹	Description
SW1_1	Cooling mode temperature compensation ²	ON 	Cooling mode temperature compensation is 0°C
		ON 	Cooling mode temperature compensation is 2°C
SW1_2	EXV positions	ON 	EXV positions 96 (steps) in standby heating mode
		ON 	EXV positions 72 (steps) in standby heating mode
SW2	Static pressure	ON 	Factory settings
SW3_1	Addressing mode	ON 	Reserved
		ON 	Clear indoor unit address
SW3_2			Reserved
SW4	Heating mode fan cycle	ON 	In heating mode when the set temperature has been reached, the fan operates in a 4 minutes off / 1 minute on repeating cycle (default)
		ON 	In heating mode when the set temperature has been reached, the fan operates in an 8 minutes off / 1 minute on repeating cycle
		ON 	In heating mode when the set temperature has been reached, the fan operates in a 12 minutes off / 1 minute on repeating cycle
		ON 	In heating mode when the set temperature has been reached, the fan operates in a 16 minutes off / 1 minute on repeating cycle
SW101	The lower air outlet	SW101 [1] ON 	The lower air outlet open
		SW101 [0] ON 	The lower air outlet close
SW102	Cold draft prevention	SW102 [00] 	In heating mode fan does not run when indoor heat exchanger mid-point temperature is 15°C or below
		SW102 [10] 	In heating mode fan does not run when indoor heat exchanger mid-point temperature is 24°C or below
		SW102 [01] 	In heating mode fan does not run when indoor heat exchanger mid-point temperature is 20°C or below

Table continued on next page ...

The 2nd Generation DC Series VRF Indoor Units

Table 2.5: Console unit main PCB settings



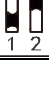



Switch	Setting	Switch positions ¹	Description
SW102	Cold draft prevention	SW102 [11] 	In heating mode fan does not run when indoor heat exchanger mid-point temperature is 26°C or below
SW103	Heating mode temperature compensation	SW103 [00] 	Heating mode temperature compensation is 6°C
		SW103 [01] 	Heating mode temperature compensation is 2°C
		SW103 [10] 	Heating mode temperature compensation is 4°C
		SW103 [11] 	Heating mode temperature compensation is 0°C
SW3_2			Reserved
J1	Auto restart	J 1 	Auto restart function enabled (default)
		J 1 	Auto restart function disabled

Table continued on next page ...

The 2nd Generation DC Series VRF Indoor Units

2.2 Modes Set on Main PCBs

2.2.1 Cooling mode temperature compensation setting

With cooling mode temperature compensation, in cooling mode the indoor units target a temperature that is lower than the set temperature. The cooling mode temperature compensation setting sets the difference between the set temperature and the target temperature. For example, if the set temperature is 26°C and the cooling mode compensation setting is 2°C, the units target an ambient temperature (sensed at the unit) of 24°C. Values of 0°C or 2°C for cooling mode temperature compensation can be selected by setting the appropriate switch on the indoor unit main PCB.

2.2.2 Heating mode temperature compensation setting

Since indoor units are often installed at ceiling level, and since warm air rises, the ambient temperature sensed at the unit can be higher than the ambient temperature where users are standing or sitting. To compensate for this, in heating mode the indoor units target a temperature that is higher than the set temperature. The heating mode temperature compensation setting sets the difference between the set temperature and the target temperature. For example, if the set temperature is 20°C and the heating mode compensation setting is 4°C, the units target an ambient temperature (sensed at the unit) of 24°C.

Depending on a variety of factors including the height of the room and the position of the units, different values may be appropriate for the heating mode temperature compensation setting. Values of 0°C, 2°C, 4°C or 6°C can be selected by setting the appropriate switch on the indoor unit main PCB.

2.2.3 Auto restart setting





The auto restart function can be used to ensure that, in the event of a power outage, the indoor units automatically restart once the power returns. When the power returns following a power outage, units with auto restart enabled restart with the same operating mode, fan speed and remote control lock status settings as before the power outage. The restart of indoor units is staggered, with the start-up of some units delayed to prevent all units starting-up simultaneously. If, during this timed delay, the remote or wired controller is used to send a command to a unit, that unit starts-up immediately with those new settings. Indoor units with auto restart disabled go into standby once the power returns following a power outage.

3 Display Panels

3.1 Appearance of Display Panel

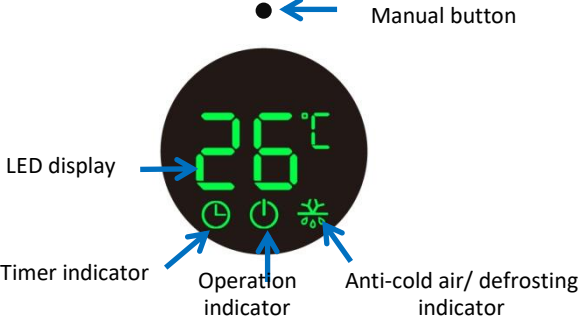
The appearance of the digital display panel used is shown in Figures 3.1.

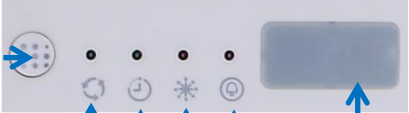
Figure 3.1: Digital display panel¹

Display panel for four-way cassette (Standard panel)	Display panel for four-way cassette (New 360 degree panel)
 <p>Labels: Manual button, LED display</p>	 <p>Labels: Manual button, LED display, Timer indicator, Operation indicator, Anti-cold air/ defrosting indicator</p>
Display panel for compact four-way cassette	Display panel for one-way cassette
 <p>Labels: LED display, Manual button</p>	 <p>Labels: Manual button, Operation indicator, Timer indicator, Anti-cold air/ defrosting indicator, Alarm indicator, LED display</p>
Display panel for ceiling and floor	Display panel for two-way cassette, floor standing, medium static pressure duct and high static pressure duct
 <p>Labels: LED display, Manual button</p>	 <p>Labels: Manual button, LED display</p>



Notes:

1. The pictures are just for reference, the exact appearance of digital panel maybe slightly different.

The 2nd Generation DC Series VRF Indoor Units

3.2 Output under Normal Operating Conditions

Table 3.1: Display panel output under normal operating conditions

Unit state		Display output	
		Lights/Icons	Digital display
Standby		OPERATION light flashes slowly	
Auto-restart delay ¹			
Shutting-down		All lights off ²	
Operating	Normal operation	OPERATION light/Icon on	Cooling and heating modes: set temperature Fan only mode: indoor ambient temperature
	Cold draft prevention ³ or outdoor unit defrosting operation ⁴	OPERATION light/Icon and DEF./FAN lights or Icon on	Set temperature
A timer has been set		TIMER light/Icon on ⁵	n/a

Notes:

1. Refer to 2.4.2 "Auto-restart setting".
2. Unless a timer has been set, in which case the TIMER light/LED will be on.
3. In heating mode, cold draft prevention ensures that the indoor unit fan only runs when the indoor heat exchanger mid-point temperature is above a certain temperature. Refer to Tables 2.1 to 2.6 in 2.1 "PCB Switch and Jumper Settings".
4. In heating mode, outdoor units perform the defrosting operation in order to recover heating capacity. Refer to the outdoor unit technical documentation.
5. The statuses of the other lights/LEDs are determined by whether the unit is currently in standby, auto-restart delay, shutting-down or operating.

3.3 Digital Display Parameter Output

On pressing the manual button^{1,2} on a digital display panel the parameters given in Table 3.2 are displayed (unless the unit is in an error state, in which case the digital display displays the error code). On the first press, parameter no. 1 is displayed, on the second press, parameter no. 2 is displayed, and so on. If the button is not pressed for 10 seconds, the display returns to its normal output, as described in Table 3.2.

Notes:

1. The manual buttons refer to 3.1 “Appearance of Display Panel”.
2. For the four-way cassette’s new 360 degree panel, a needle is necessary to active manual button.

3.3.1 Spot check table (Before upgrade of indoor unit’s main program software)

Table 3.1: Digital display output when button on a digital display panel is pressed(Not include fresh air processing unit)

Parameter no.	Parameters	Remarks
0	Normal display	
1	Communication address ¹	0 - 63
2	Capacity as set on switch ENC1 on indoor unit main PCB	Unit: HP
3	Network address ¹	0 - 63
4	Actual set temperature Ts	
5	Actual T1 indoor temperature	Minimum value -9°C
6	Actual T2 indoor heat exchanger mid-point temperature	Minimum value -9°C
7	Actual T2A Indoor heat exchanger inlet temperature	Minimum value -9°C
8	Actual T2B Indoor heat exchanger outlet temperature	Minimum value -9°C
9	Compressor discharge temperature	
10	Target superheat (reserved)	
11	EXV openness (actual openness / 8)	
12	Version number of indoor unit’s main program software	
13	Error code (last time)	
14	--	

Notes:

1. On indoor units, the communication address and network address are the same and are routinely referred to simply as the unit’s “address”.

The 2nd Generation DC Series VRF Indoor Units

3.3.2 Spot check table (After upgrade of indoor unit's main program software)

Table 3.3: Digital display output when button on a digital display panel is pressed (Not include fresh air processing unit)

Parameter no.	Parameters	Remarks
0	Normal display	
1	Communication address ¹	0 - 63
2	Capacity as set on switch ENC1 on indoor unit main PCB	Unit: HP
3	Network address ¹	0 - 63
4	Actual set temperature Ts	
5	Actual T1 indoor temperature	Minimum value -9°C
6	Actual T2 indoor heat exchanger mid-point temperature	Minimum value -9°C
7	Actual T2A Indoor heat exchanger inlet temperature	Minimum value -9°C
8	Actual T2B Indoor heat exchanger outlet temperature	Minimum value -9°C
9	Compressor discharge temperature	
10	Target superheat (reserved)	
11	EXV openness (actual openness / 8)	
12	Version number of indoor unit's main program software	
13	Swing small board software version number	
14	Error code 1 (last time)	
15	Error code 2 (last but one)	
16	Error code 3 (last but two)	
17	Number of PQE address settings (Record 99 times at most)	
18	The number of times the remote controller sets the address (99 times at most)	
19	The number of times the wired controller sets the address (99 times at most)	
20	--	

Notes:

1. On indoor units, the communication address and network address are the same and are routinely referred to simply as the unit's "address".

4 Errors

4.1 Error Code Table

Table 4.1: Error code table

Error code	Content
E0	Mode conflict
E1	Communication error between indoor and outdoor units
E2	Indoor ambient temperature sensor error
E3	Indoor heat exchanger mid-point temperature sensor error
E4	Indoor heat exchanger outlet temperature sensor error
E6	Fan error
E7	EEPROM mismatch
Eb	Electronic expansion valve error
Ed	Outdoor unit error
EE	Water level error
FE	Indoor unit has not been assigned an address
A1	Refrigerant leakage fault
A0	The emergency stop
F7+ repeated address	Repeated indoor units address
U4	MS box self-check failure
F8	MS box Error

The 2nd Generation DC Series VRF Indoor Units

4.2 Impact on Other Units

Table 4.2 shows the impact of an error on one indoor unit on the outdoor units and on the other indoor units in the system. The actual state of the outdoor units and the other indoor units is determined not only by the impacts shown in Table 4.2, but also by any other errors that may have separately arisen on the outdoor units or other indoor units.

Table 4.2: Impact of indoor unit error on outdoor units and on other indoor units

Indoor unit error	Impact on outdoor units	Impact on other indoor units
E0	Minimal impact ¹	No impact
E1	H7 error ²	Ed error ³
E2	Minimal impact ⁴	No impact
E3	Minimal impact ⁴	No impact
E4	Minimal impact ⁴	No impact
E6	Minimal impact ⁴	No impact
E7	Minimal impact ⁴	No impact
Eb	Minimal impact ⁴	No impact
Ed	n/a ⁵	n/a ⁵
EE	Minimal impact ⁴	No impact
FE	H7 error ²	Ed error ³
A1 ⁶	No impact	Ed error ³
A0 ⁶	No impact	Ed error ³
F7+ repeated address ⁶	No impact	No impact
U4 ⁶	No impact	No impact
F8 ⁶	No impact	Ed error ³

Notes:

1. The outdoor units continue to operate and ignore the load requirement from the indoor unit that has gone into mode conflict with the outdoor units.
2. Outdoor unit error code H7 indicates that the number of indoor units detected by the master outdoor unit is not the same as the number set on the master outdoor unit's main PCB.
3. Error Ed may not be displayed on the other indoor units. Indoor unit error codes have the following order of priority: A1-A0-FE-F7-E0-E1-E2-E3-E4-E6-E7-Eb-Ed-EE-U4-F8. So if, for example, one unit has an E2 error, it continues to display E2 even if an E1 or FE error occurs on another indoor unit (giving rise to an outdoor unit H7 error) since error Ed is lower in the order of priority than error E2.
4. The outdoor units continue to operate but detect no load requirement from the indoor unit that has experienced an E2, E3, E4, E6, E7, Eb or EE error, and adjust their output accordingly, in the same way as they do when a user puts an indoor unit into standby.
5. An indoor unit Ed error is caused by (and not the cause of) an outdoor unit error. The outdoor units will be displaying their own error code.
6. Only applicable for V6R system.

5 Troubleshooting

5.1 Warning

Warning



- All electrical work must be carried out by competent and suitably qualified, certified and accredited professionals and in accordance with all applicable legislation (all national, local and other laws, standards, codes, rules, regulations and other legislation that apply in a given situation).
- Power-off the unit before connecting or disconnecting any connections or wiring, otherwise electric shock (which can cause physical injury or death) may occur or damage to components may occur.

The 2nd Generation DC Series VRF Indoor Units

5.2 E0 Troubleshooting

5.2.1 Display output



5.2.2 Description

- Mode conflict.

5.2.3 Impact on other units

- Refer to [4.2 "Impact on Other Units"](#).

5.2.4 Possible causes

- The indoor unit's operating mode conflicts with that of the outdoor units.

5.2.5 Explanation

There are five priority mode options, which are set on the outdoor units. If an indoor unit's operating mode conflicts with that of the outdoor units, the indoor unit displays the mode conflict error. The five priority modes are:

1. **Heating priority mode (default):**
 - a) **During cooling operation:** If an indoor unit requests heating, the outdoor units stop and then restart in heating mode after 5 minutes. Indoor units requesting heating then start in heating mode and indoor units requesting cooling display the mode conflict error.
 - b) **During heating operation:** If an indoor unit requests cooling, the outdoor units ignore the request and continue to run in heating mode. The indoor unit requesting cooling displays the mode conflict error. If all the indoor units requesting heating are later turned off and one or more indoor units are still requesting cooling, the outdoor units restart in cooling mode after 5 minutes and any indoor units requesting cooling then start in cooling mode.
2. **Cooling priority mode:**
 - a) **During heating operation:** If an indoor unit requests cooling, the outdoor units stop and then restart in cooling mode after 5 minutes. Indoor units requesting cooling then start in cooling mode and indoor units requesting heating display the mode conflict error.
 - b) **During cooling operation:** If an indoor unit requests heating, the outdoor units ignore the request and continue to run in cooling mode. The indoor unit requesting heating displays the mode conflict error. If all the indoor units requesting cooling are later turned off and one or more indoor units are still requesting heating, the outdoor units restart in heating mode after 5 minutes and any indoor units requesting heating then start in heating mode.
3. **VIP priority mode or voting priority mode:** 63 is the VIP address. If the VIP indoor unit is operating, the outdoor units operate in the mode of the VIP indoor unit. Indoor units that are in a mode different to that of the VIP unit display the mode conflict error. If there is no unit with address 63 or the unit at address 63 is in standby, the outdoor units operate in voting priority mode. In voting priority mode, the outdoor units operate in whichever of heating and cooling modes is being requested by the larger number of indoor units.
4. **Heating only mode:** The outdoor units only operate in heating mode. Indoor units requesting heating operate in heating mode. Indoor units requesting cooling or in fan only mode display the mode conflict error.
5. **Cooling only mode:** The outdoor units only operate in cooling mode. Indoor units requesting cooling operate in cooling mode; indoor units in fan only mode operate in fan only mode. Indoor units requesting heating display the mode conflict error.

The 2nd Generation DC Series VRF Indoor Units

5.3 E1 Troubleshooting

5.3.1 Display output



5.3.2 Description

- Communication error between indoor and outdoor units.

5.3.3 Impact on other units

- Refer to [4.2 "Impact on Other Units"](#).

5.3.4 Possible causes

- Communication wires between indoor and outdoor units not connected properly.
- Interference from high voltage wires or other sources of electromagnetic radiation.
- Communication wire too long.
- Damaged main PCB.

5.3.5 Procedure

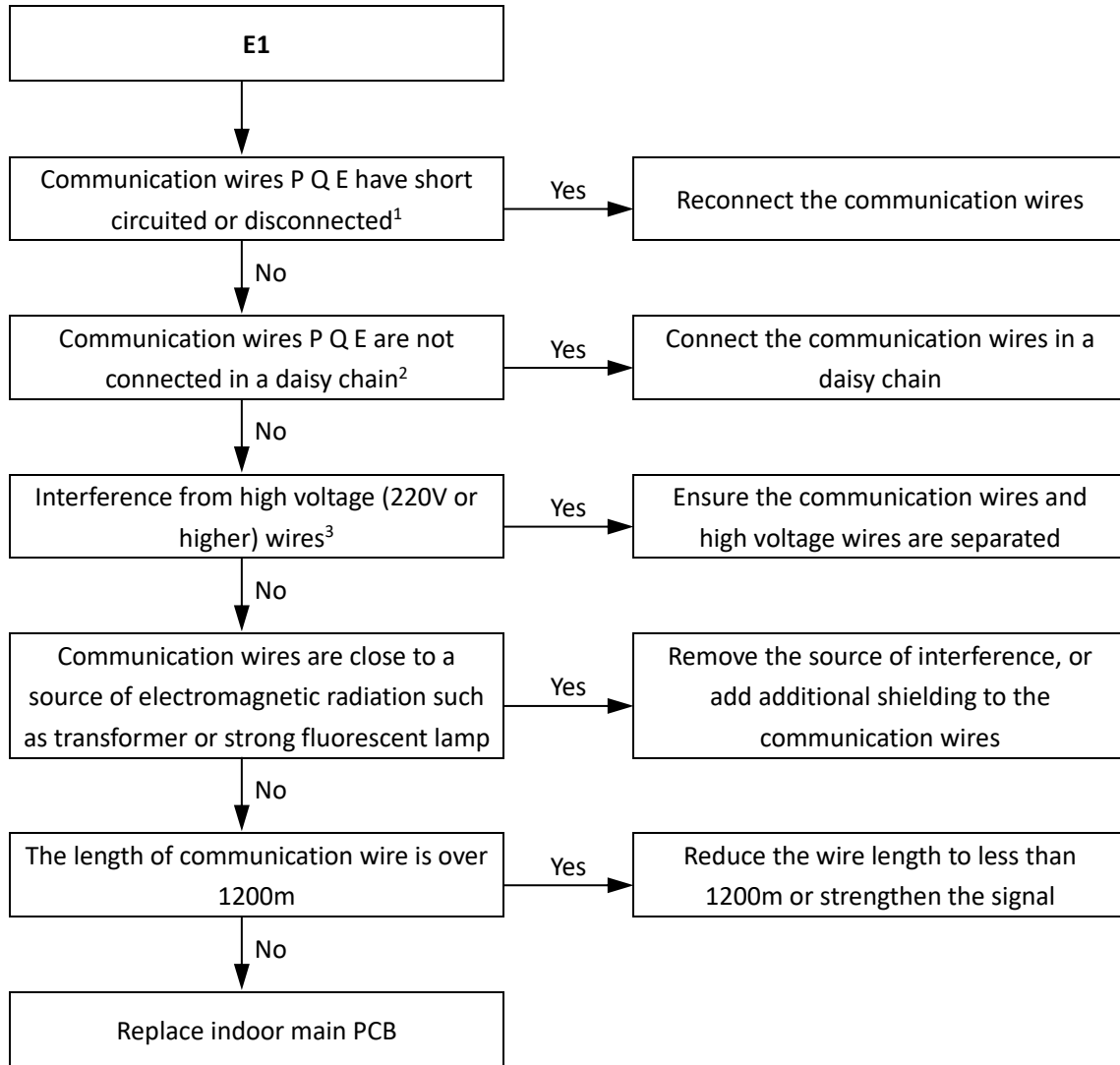

Notes:

1. Measure the resistance among P, Q and E. The normal resistance between P and Q is 120Ω, between P and E is infinite, between Q and E is infinite.
2. The P Q E communication wires should be connected one unit after another in a daisy chain from the master outdoor unit to the final indoor unit. After the final indoor unit, the communication wiring should NOT be continued back to the outdoor units – that is, do not attempt to form a closed loop.
3. The refrigerant piping, power wiring and communication wiring are typically run in parallel. However the communication wiring should not be bound together with the refrigerant piping or power wiring. To prevent signal interference, the power wiring and communication wiring should not be run in the same conduit. If the power supply is less than 10A, a separation of at least 300mm between power wiring and communication wiring conduits should be maintained; if the power supply is in the range 10A to 50A then a separation of at least 500mm should be maintained.

The 2nd Generation DC Series VRF Indoor Units

5.4 E2, E3, E4 Troubleshooting

5.4.1 Display output



5.4.2 Description

- E2 indicates an indoor ambient temperature sensor error.
- E3 indicates an indoor heat exchanger mid-point temperature sensor error.
- E4 indicates an indoor heat exchanger outlet temperature sensor error.

5.4.3 Impact on other units

- Refer to 4.2 “Impact on Other Units”.

5.4.4 Possible causes

- Temperature sensor not connected properly or has malfunctioned.
- Damaged main PCB.

5.4.5 Procedure

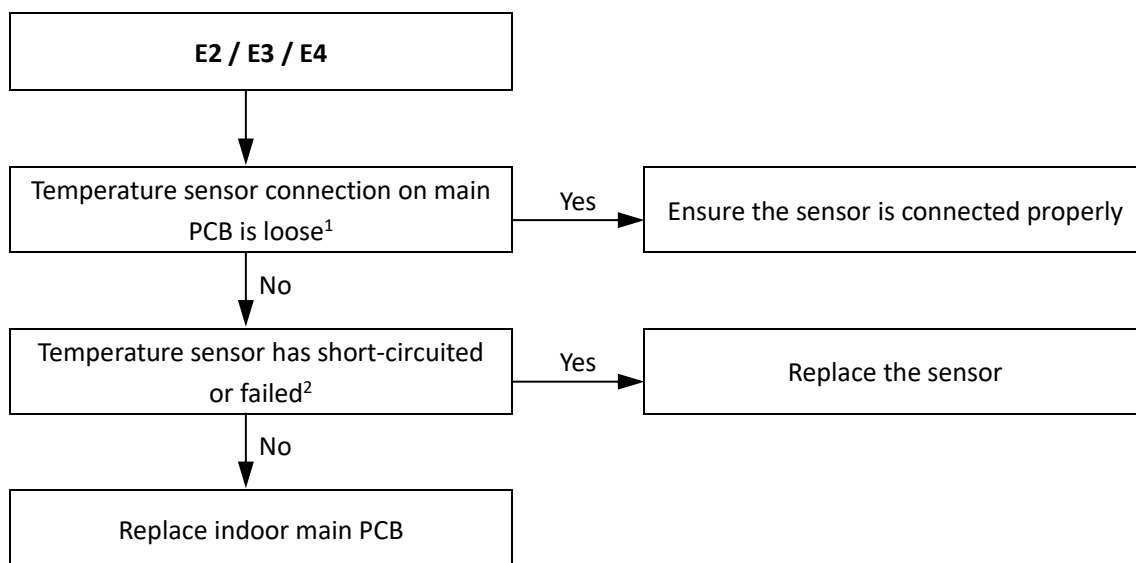

Notes:

1. The indoor ambient temperature sensor connection port, indoor heat exchanger mid-point temperature sensor connection port and indoor heat exchanger outlet temperature sensor connection port on each type of indoor unit main PCB are labeled in Figures 1.1 to 1.19 in 1, “Main PCB Ports”.
2. Measure sensor resistance. If the resistance is too low, the sensor has short-circuited. If the resistance is not consistent with the sensor’s resistance characteristics table, the sensor has failed. Refer to Table 6.1 in 6.1 “Temperature Sensor Resistance Characteristics”.

5.5 E6 Troubleshooting

5.5.1 Display output



5.5.2 Description

- Fan error.
- Either the main PCB cannot detect the fan, or the difference between the actual fan speed and the target fan speed exceeds the limit.

5.5.3 Impact on other units

- Refer to [4.2 "Impact on Other Units"](#).

5.5.4 Possible causes

- Fan stuck or blocked.
- Fan motor not connected properly or has malfunctioned.
- Power supply abnormal.
- Damaged main PCB.

The 2nd Generation DC Series VRF Indoor Units

5.5.5 Procedure

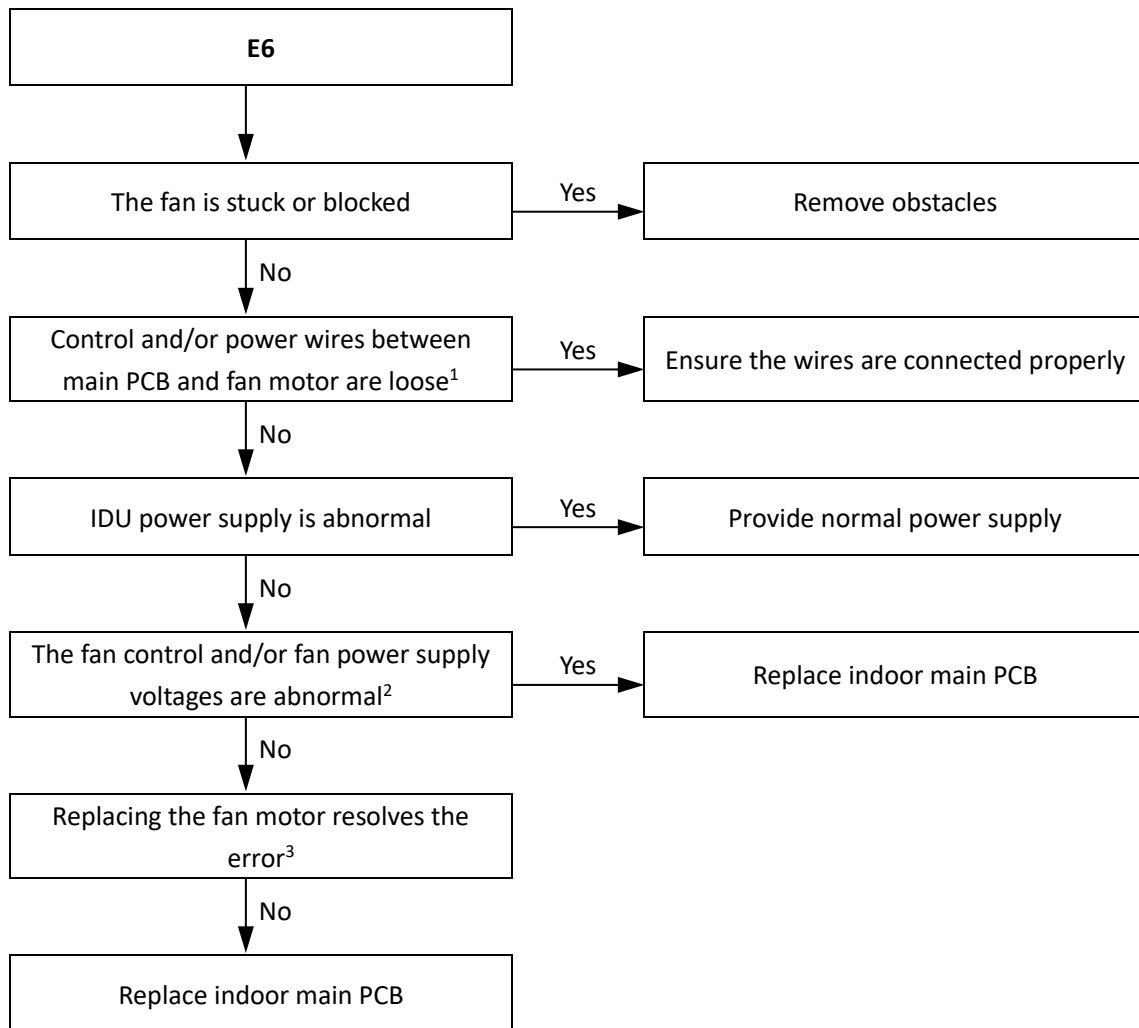

Notes:

1. The fan connection on each type of indoor unit main PCB is labeled in Figures 1.1 to 1.19 in 1, “Main PCB Ports”.
2. Measure the voltage between the red and black wires and between the white and black wires at the fan connection on the indoor unit main PCB. The normal voltage between the red and black wires is 310V (DC); the normal voltage between the white and black wires is 15V (DC). The fan connection on each type of indoor unit main PCB is labeled in Figures 1.1 to 1.19 in 1, “Main PCB Ports”. Refer also to Figure 5.1.
3. Remove the fan motor and install a new one. Power-on the unit, set it to run with fan speed set to low, and see if the unit runs normally or not.

Figure 5.1: Fan connection wiring on indoor unit main PCBs



5.6 E7 Troubleshooting

5.6.1 Display output



5.6.2 Description

- EEPROM mismatch.

5.6.3 Impact on other units

- Refer to [4.2 "Impact on Other Units"](#).

5.6.4 Possible causes

- Damaged main PCB.

5.6.5 Procedure

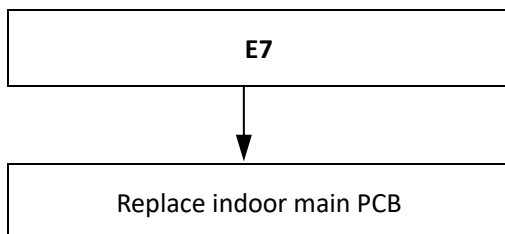

The 2nd Generation DC Series VRF Indoor Units

5.7 Eb Troubleshooting

5.7.1 Display output



5.7.2 Description

- Electronic expansion valve error.

5.7.3 Impact on other units

- Refer to 4.2 “Impact on Other Units”.

5.7.4 Possible causes

- Electronic expansion valve coil not connected properly or has malfunctioned.
- Damaged main PCB.

5.7.5 Procedure

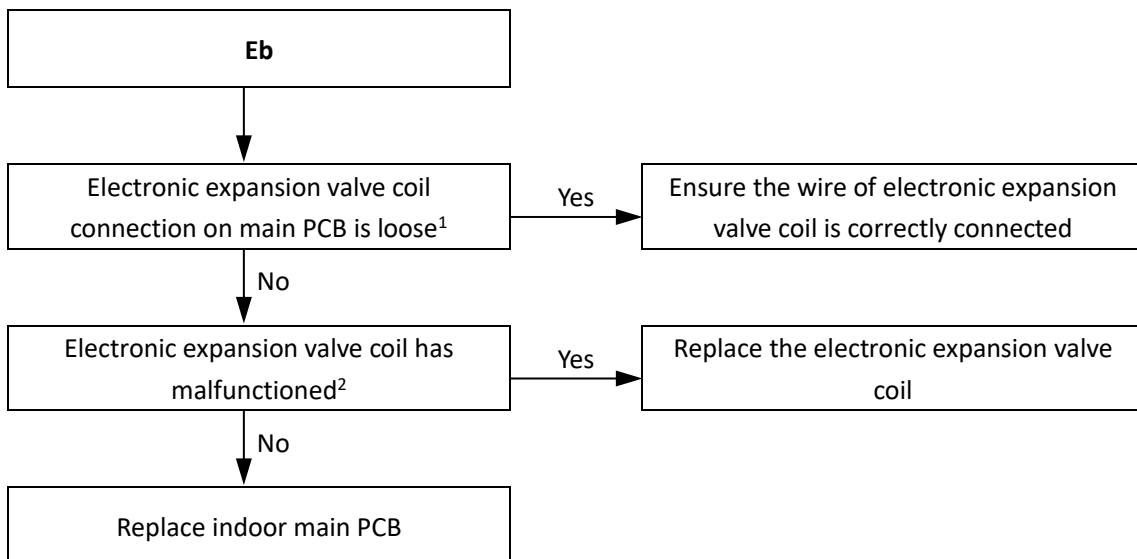

Notes:

1. The electronic expansion valve connection port on each type of indoor unit main PCB is labeled in Figures 1.1 to 1.19 in 1, “Main PCB Ports”.
2. The normal resistances between EXV coil wiring terminals RED and white / yellow / orange / blue are 40-50Ω. If any of the resistances is 0 or infinity, the EXV coil has malfunctioned.

Figure 5.2: EXV coil wiring terminals

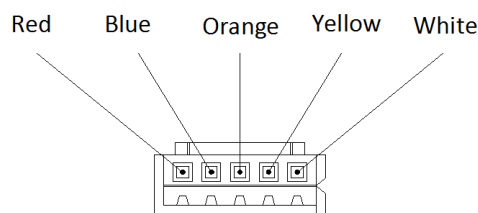

5.8 Ed Troubleshooting

5.8.1 Display output



5.8.2 Description

- Outdoor unit error.

5.8.3 Impact on other units

- Refer to [4.2 "Impact on Other Units"](#).

5.8.4 Possible causes

- Outdoor unit error.

5.8.5 Procedure

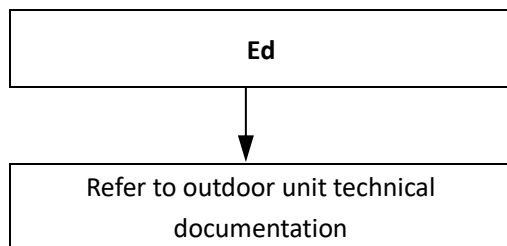

The 2nd Generation DC Series VRF Indoor Units

5.9 EE Troubleshooting

5.9.1 Display output

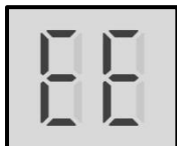

5.9.2 Description

- Water level error.

5.9.3 Impact on other units

- Refer to 4.2 “Impact on Other Units”.

5.9.4 Possible causes

- Water level float stuck.
- Water level switch not connected properly.
- Damaged main PCB.
- Drain pump has malfunctioned.

5.9.5 Procedure

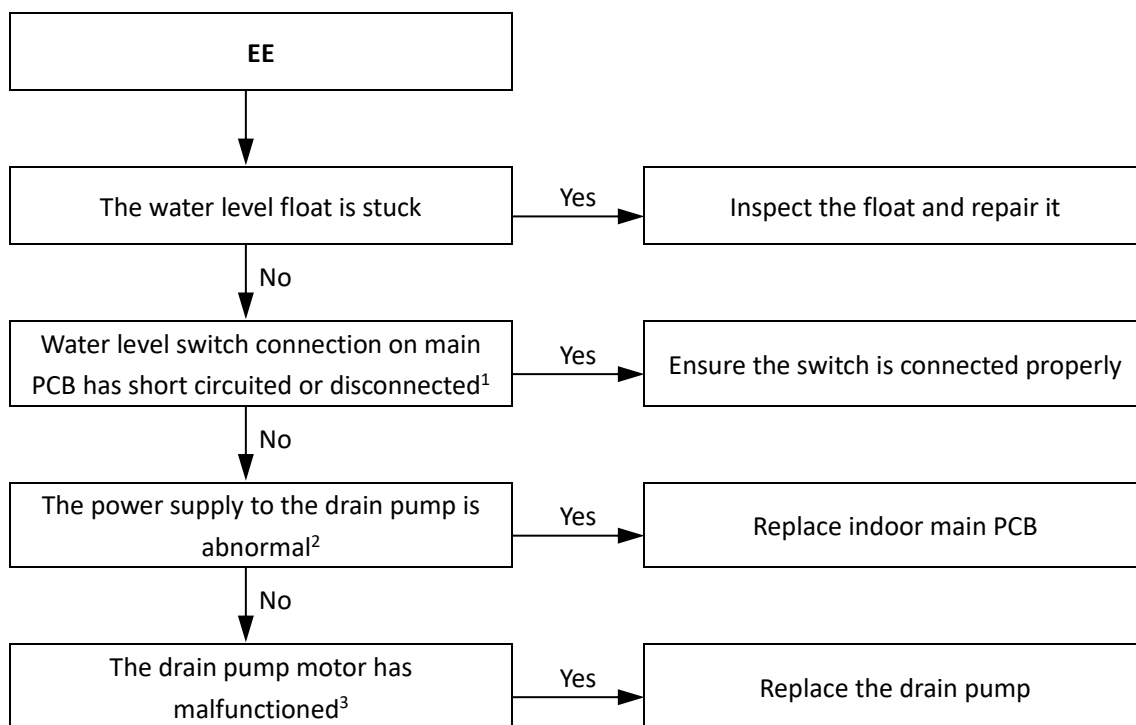

Notes:

- The water level switch connection port on each type of indoor unit main PCB is labeled in Figures 1.1 to 1.19 in 1, “Main PCB Ports”.
- Measure the voltage between the two pins of the drain pump connection on the indoor unit main PCB. The normal voltage range is 220 to 240 V (AC). The drain pump connection port on each type of indoor unit main PCB is labeled in Figures 1.1 to 1.19 in 1, “Main PCB Ports”.
- Measure the resistance between the two power supply terminals on the drain pump motor. If the resistance is either zero or infinite, the motor has malfunctioned.

5.10 FE Troubleshooting

5.10.1 Display output



5.10.2 Description

- Indoor unit has not been assigned an address.

5.10.3 Impact on other units

- Refer to [4.2 "Impact on Other Units"](#).

5.10.4 Possible causes

- Indoor unit has not been assigned an address.

5.10.5 Procedure

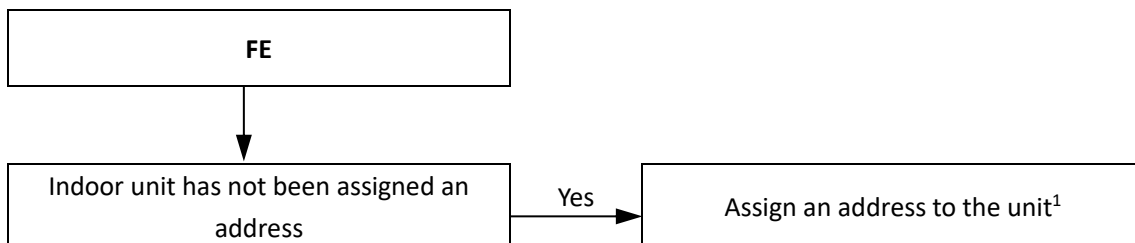

Notes:

- Indoor unit addresses can be manually assigned using indoor unit remote/wired controllers. Alternatively, indoor unit addresses can be automatically assigned by the master outdoor unit. Refer to the outdoor unit technical documentation. Note: Each unit in a system should be assigned a unique address - unit addresses should not be repeated within one system.

The 2nd Generation DC Series VRF Indoor Units

5.11 Louver Swing Failure Troubleshooting

5.11.1 Display output

- No special display output or error code.

5.11.2 Description

- Louvers fail to respond to instruction from wired or remote controller.

5.11.3 Possible causes

- Louver swing motor not connected properly or has malfunctioned.
- Damaged main PCB.

5.11.4 Procedure

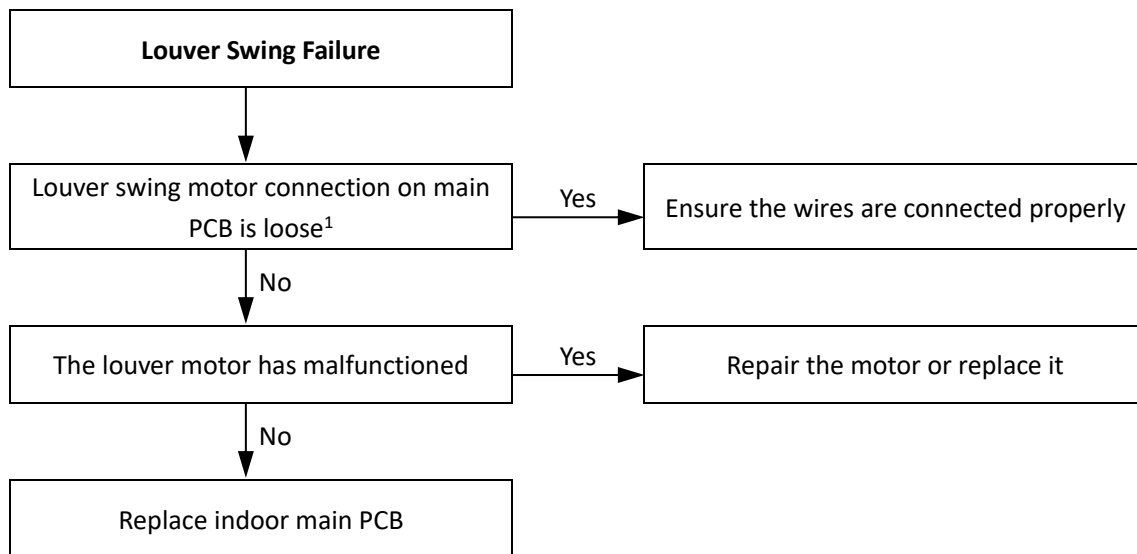

Notes:

1. The louver swing motor connection on each type of indoor unit main PCB is labeled in Figures 1.1 to 1.19 in 1, “Main PCB Ports”.
2. Measure the resistance between the red wire and each of the other four wires (orange, yellow, pink and blue) at the louver swing motor connection on the main PCB. The resistances between the red wire and each of the other four wires should all be the same, should not be zero and should not be infinite. If the resistances are not the same, or if any of the resistances are zero or infinite, the louver swing motor has malfunctioned. The louver swing motor connection on each type of indoor unit main PCB is labeled in Figures 1.1 to 1.19 in 1, “Main PCB Ports”. Refer also to Figure 5.2.

Figure 5.2: Louver swing motor connection wiring on indoor unit main PCBs

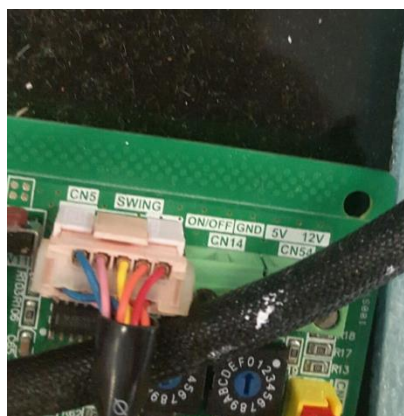

5.12 A1 Troubleshooting

5.12.1 Display output



5.12.2 Description

- Refrigerant leakage fault.

5.12.3 Impact on other units

- Refer to 4.2 “Impact on Other Units”.

5.12.4 Possible causes

- MS box actually detects that the quantity of connected refrigerant leakage sensors is not same as the quantity of sensors set by ENC1
- The refrigerant leakage sensor is open circuit, that is refrigerant leakage occurs
- MS box PCB malfunction

5.12.5 Procedure

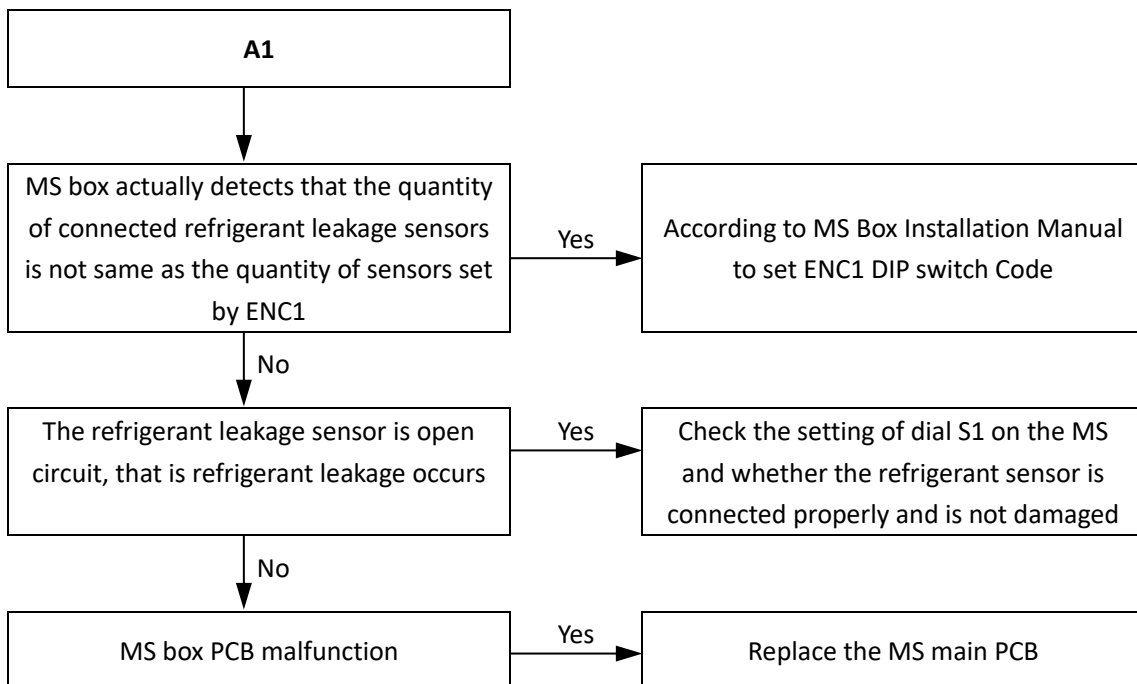

The 2nd Generation DC Series VRF Indoor Units

5.13 A0 Troubleshooting

5.13.1 Display output



5.13.2 Description

- The emergency stop.

5.13.3 Impact on other units

- Refer to [4.2 "Impact on Other Units"](#).

5.13.4 Possible causes

- MS box actually detects that the quantity of connected refrigerant leakage sensors is not same as the quantity of sensors set by ENC1
- The refrigerant leakage sensor is open circuit, that is refrigerant leakage occurs
- MS box PCB malfunction

5.13.5 Procedure

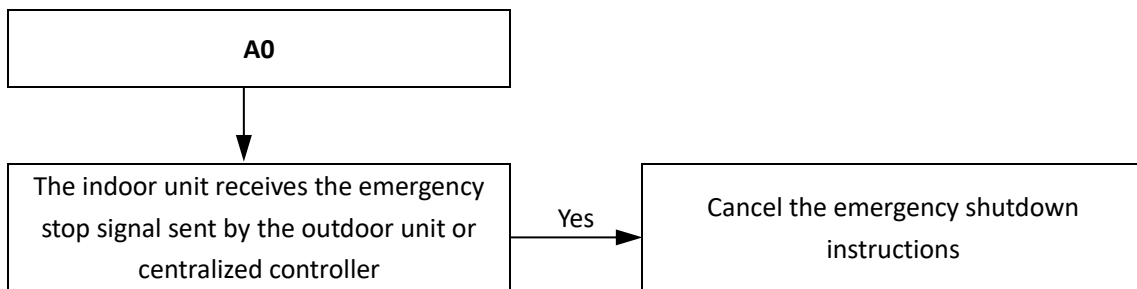

5.14 F7+repeated address (Alternating display with 1s as cycle) Troubleshooting

5.14.1 Display output



5.14.2 Description

- Repeated indoor units address.

5.14.3 Impact on other units

- Refer to [4.2 "Impact on Other Units"](#).

5.14.4 Possible causes

- Multiple virtual addresses will appear in high pressure duct 20-56kw. And it didn't restart after setting the unit capacity. The refrigerant leakage sensor is open circuit, that is refrigerant leakage occurs
- There are other indoor units that repeat the address.

5.14.5 Procedure

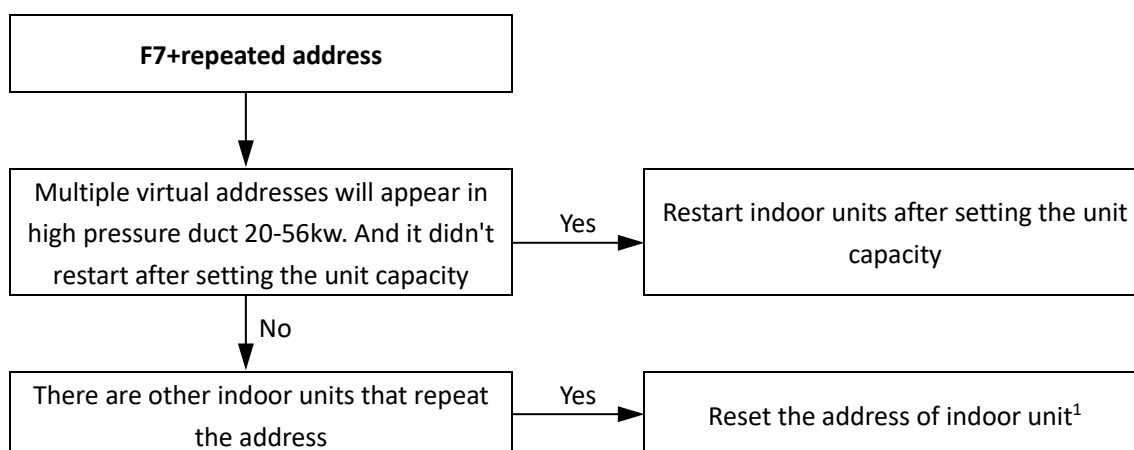

Notes:

1. The repeated address displayed on the display board cannot be used. The address range is 0-63#

The 2nd Generation DC Series VRF Indoor Units

5.15 U4 Troubleshooting

5.15.1 Display output



5.15.2 Description

- MS box self-check failure.

5.15.3 Impact on other units

- Refer to [4.2 "Impact on Other Units"](#).

5.15.4 Possible causes

- During the commissioning of the outdoor unit, the Outdoor find the indoor unit PQE connection and real refrigerant pipe connection is mismatch under the MS.

5.15.5 Procedure

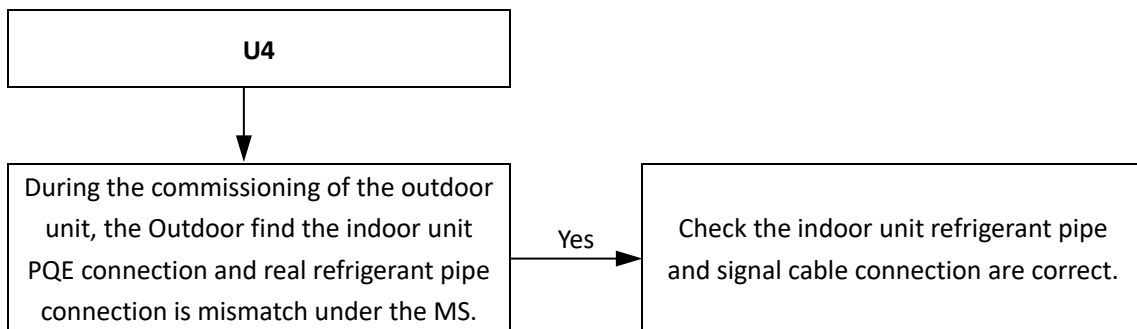

5.16 F8 Troubleshooting

5.16.1 Display output



5.16.2 Description

- MS box Error.

5.16.3 Impact on other units

- Refer to [4.2 "Impact on Other Units"](#).

5.16.4 Possible causes

- The connected MS box has error or protection.

5.16.5 Procedure

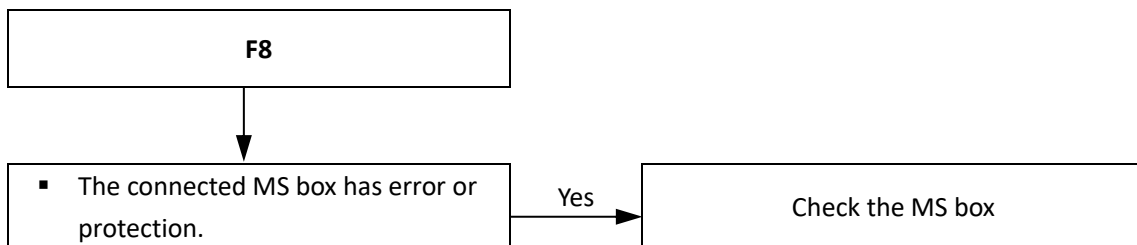

The 2nd Generation DC Series VRF Indoor Units

6 Appendix

6.1 Temperature Sensor Resistance Characteristics

Table 6.1: Indoor ambient temperature sensor, indoor heat exchanger mid-point temperature sensor and indoor heat exchanger outlet

Temperature (°C)	Resistance (kΩ)	Temperature (°C)	Resistance (kΩ)	Temperature (°C)	Resistance (kΩ)	Temperature (°C)	Resistance (kΩ)
-20	115.3	20	12.64	60	2.358	100	0.6297
-19	108.1	21	12.06	61	2.272	101	0.6115
-18	101.5	22	11.50	62	2.191	102	0.5939
-17	96.34	23	10.97	63	2.112	103	0.5768
-16	89.59	24	10.47	64	2.037	104	0.5604
-15	84.22	25	10.00	65	1.965	105	0.5445
-14	79.31	26	9.551	66	1.896	106	0.5291
-13	74.54	27	9.124	67	1.830	107	0.5143
-12	70.17	28	8.720	68	1.766	108	0.4999
-11	66.09	29	8.336	69	1.705	109	0.4860
-10	62.28	30	7.971	70	1.647	110	0.4726
-9	58.71	31	7.624	71	1.591	111	0.4596
-8	56.37	32	7.295	72	1.537	112	0.4470
-7	52.24	33	6.981	73	1.485	113	0.4348
-6	49.32	34	6.684	74	1.435	114	0.4230
-5	46.57	35	6.400	75	1.387	115	0.4116
-4	44.00	36	6.131	76	1.341	116	0.4006
-3	41.59	37	5.874	77	1.291	117	0.3899
-2	39.82	38	5.630	78	1.254	118	0.3796
-1	37.20	39	5.397	79	1.2133	119	0.3695
0	35.20	40	5.175	80	1.174	120	0.3598
1	33.33	41	4.964	81	1.136	121	0.3504
2	31.56	42	4.763	82	1.100	122	0.3413
3	29.91	43	4.571	83	1.064	123	0.3325
4	28.35	44	4.387	84	1.031	124	0.3239
5	26.88	45	4.213	85	0.9982	125	0.3156
6	25.50	46	4.046	86	0.9668	126	0.3075
7	24.19	47	3.887	87	0.9366	127	0.2997
8	22.57	48	3.735	88	0.9075	128	0.2922
9	21.81	49	3.590	89	0.8795	129	0.2848
10	20.72	50	3.451	90	0.8525	130	0.2777
11	19.69	51	3.318	91	0.8264	131	0.2708
12	18.72	52	3.192	92	0.8013	132	0.2641
13	17.80	53	3.071	93	0.7771	133	0.2576
14	16.93	54	2.959	94	0.7537	134	0.2513
15	16.12	55	2.844	95	0.7312	135	0.2451
16	15.34	56	2.738	96	0.7094	136	0.2392
17	14.62	57	2.637	97	0.6884	137	0.2334
18	13.92	58	2.540	98	0.6682	138	0.2278
19	13.26	59	2.447	99	0.6486	139	0.2223



OMEGA
ENVIRONMENTAL
TECHNOLOGIES LLC.

17702 Mitchell North, #101
Irvine, CA. 92614 .USA
Tel: 714 795 2830
Fax: 714 966 1646
info@omegavrf.com
www.omegavrf.com

OTECTM
AIR CONDITIONING

Showroom & Technology Center
11380 Interchange Circle North
Miramar, FL 33025 .USA
Tel: 305 901 1270
Fax: 954 212 8280
info@otecomega.com
www.otecomega.com

VECRQ0A-SM1D0123