

IEWV(ICHV) - Y Series

High Wall Inverter Service Manual

208-230V/1/60Hz

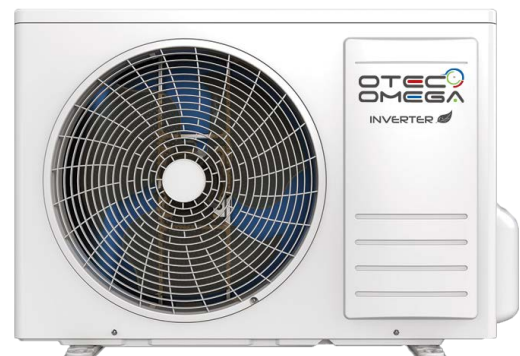

CONTENT

1. Troubleshooting	1
1.1 Error Code List.....	1
1.2 PCB Printed Diagram	4
1.3 Procedure of Troubleshooting	9
1.4 Troubleshooting for Normal Macfunction.....	22
2. Removal Procedure	27
2.1 Removal Procedure of Indoor Unit	27
2.2 Removal Procedure of Outdoor Unit	31

1. Troubleshooting

1.1 Error Code List

No.	Name of malfunction and status	Remark	Error code	Way of display	Aftersales	Operation
1	Oil return in cooling mode		b0	Display by remote controller	Normal	Push light "+" "-" button 3s to eliminate the display
2	Cold air protection		b1	Display by remote controller	Normal	Push light "+" "-" button 3s to eliminate the display
3	Filter cleaning		b3	Display directly	Filter need to be cleaned	Cleaning the filter
4	Defrost or oil return in heating mode	Display one time after running 10s	dF	Display by remote controller	Normal	Normal
5	Compressor phase current electric circuit failure		H6	Display directly	Outdoor mainboard electric circuit broken	Change the mainboard
6	Compressor phase loss protection		H7	"Display by remote controller within compressor stop 200s or Display directly after compressor stop 200s"	Reason: 1.mainboard broken 2.mainboard and compressor un-connected 3.compressor broken	1.change the mainboard. 2.check the connecting of compressor and mainboard. 3.Change compressor.
7	Outdoor DC motor protection	Including outdoor motor module protection/phase loss protection/step loss protection	H8	Display by remote controller within compressor stop 200s or Display directly after compressor stop 200s	Reason: 1.Outdoor motor fan air duct block 2.Cause by typhoon 3. Outdoor motor fan three Phase resistance equal to two phase resistance; 4. mainboard broken	1.remove the block 2.change the motor fan 3.change the mainboard
8	Outdoor DC motor phase current electric circuit failure		H9	Display directly	Outdoor mainboard electric circuit broken	Change the mainboard
9	Jumper failure		L0	Display directly	1.Un-install jumper in indoor and outdoor. 2.Jumper plug failure. 3.mainboard check the jumper electric circuit failure.	Change the jumper or mainboard
10	Indoor alternating current zero point failure		L1	Display directly	Indoor mainboard broken	Change the indoor mainboard
11	Indoor motor failure		L2	Display directly	1.Indoor motor blockage. 2.Indoor motor wire loosen. 3.Indoor motor broken.	Change the indoor mainboard or motor fan
12	Communication failure		L3	Display directly	Mainboard broken or wire un-connected	Change the mainboard
13	Outdoor EEPROM failure		P0	Display directly	Outdoor mainboard electric circuit failure	Change the outdoor mainboard

No.	Name of malfunction and status	Remark	Error code	Way of display	After sales	Operation
15	Power on failure		P1	Display directly	Outdoor mainboard electric circuit broken/ wire un-connect/ reactor broken	1.Check the connection of outdoor mainboard power. 2.Check the reactor. 3.Check the outdoor AC return after power off.
16	Alternating current protection		P2	Display by remote controller within compressor stop 200s or Display directly after compressor stop 200s	Outdoor mainboard electric circuit broken.	Change the mainboard
17	High Voltage protection		P3	Display by remote controller within compressor stop 200s or Display directly after compressor stop 200s	1.Check the input AC voltage. 2.Change outdoor mainboard.	1.Check the voltage of power supply . 2.Change the mainboard after power on and off.
18	Low voltage protection		P4	Display by remote controller within compressor stop 200s or Display directly after compressor stop 200s	1.Check the input AC voltage. 2.Change outdoor mainboard.	1.Check the voltage of power supply. 2. Change the mainboard after power on and off.
19	DC line voltage drop protection		P5	Display by remote controller within compressor stop 200s or Display directly after compressor stop 200s	1.check the input AC voltage. 2.change outdoor mainboard.	1.Check the voltage of power supply. 2.Change the mainboard after power on and off.
20	Current checking electric circuit failure		P6	Display directly	1.Refrigerant leakage. 2.Outdoor mainboard electric circuit broken	1.Change the refrigerant leakage. 2.change the mainboard.
21	Current protection		P7	Display by remote controller within compressor stop 200s or Display directly after compressor stop 200s	Current is above the max No.	1.Check the input AC voltage. 2.Check the system blockage. 3.Change the mainboard.
22	PFC current checking electric circuit failure		P8	Display directly	Outdoor mainboard electric circuit broken	Change the mainboard
23	PFC protection		P9	Display by remote controller within compressor stop 200s or Display directly after compressor stop 200s	1.check the input AC voltage. 2.change outdoor mainboard.	1.Check the AC voltage. 2.Change the mainboard.
24	Indoor and outdoor un-match failure		PA	Display directly	Indoor jumper mistake	Change the junper
25	Indoor temperature sensor short circuit failure		U0	Display directly	Check indoor temperature sensor	Change the sensor.If still not work,change the mainboard

No.	Name of malfunction and status	Remark	Error code	Way of display	After sales	Operation
26	Indoor pipe sensor short circuit failure		U1	Display directly	Check indoor pipe sensor short	Change the sensor.If still not work,change the mainboard
27	Outdoor temperature sensor short circuit failure		U2	Display directly	Check outdoor temperature sensor	Change the sensor.If still not work,change the mainboard
28	Outdoor pipe sensor short circuit failure		U3	Display directly	Check outdoor pipe sensor	Change the sensor.If still not work,change the mainboard
29	Outdoor discharge sensor short circuit failure		U4	Display directly	Check outdoor discharge sensor	Change the sensor.If still not work,change the mainboard
30	Compressor module sensor short circuit failure		U5	Display directly	Change the mainboard	Change the outdoor mainboard
31	Discharge sensor invalid		U8	Display directly	Check Discharge sensor	Check the position of sensor,if it is in the right position,change the sensor.If it still not work,change the mianboard
32	High discharge air temperature		E0	Display by remote controller wthin compressor stop 200s or Display directly after compressor stop 200s	Motor fan air duct block. Evaporator is dirty.	Please refer to the malfunction analysis (discharge protection, overload).
33	Anti freezing protection		E3	Display by remote controller wthin compressor stop 200s or Display directly after compressor stop 200s	Check Poor air-return in indoor unit and evaporator.	1. Poor air-return in indoor unit; 2. Fan speed is abnormal 3. Evaporator is dirty.
34	4-Way valve malfunction		E7	Display by remote controller wthin compressor stop 200s or Display directly after compressor stop 200s	1.Check the input AC voltage. 2.Check 4-Way valve.	1.Supply voltage is lower than AC 175V; 2.Wiring terminal 4V is loosened or broken; 3.4-Way valve is damaged, please replace 4-Way valve .
35	High or low Outdoor temperature protection		E8	Display by remote controller	Check outdoor ambient temperature in normal range?	Normal protection, please operate it after the outdoor ambient temperature is normalized.

1.2 PCB Printed Diagram

Indoor Unit

TOP VIEW

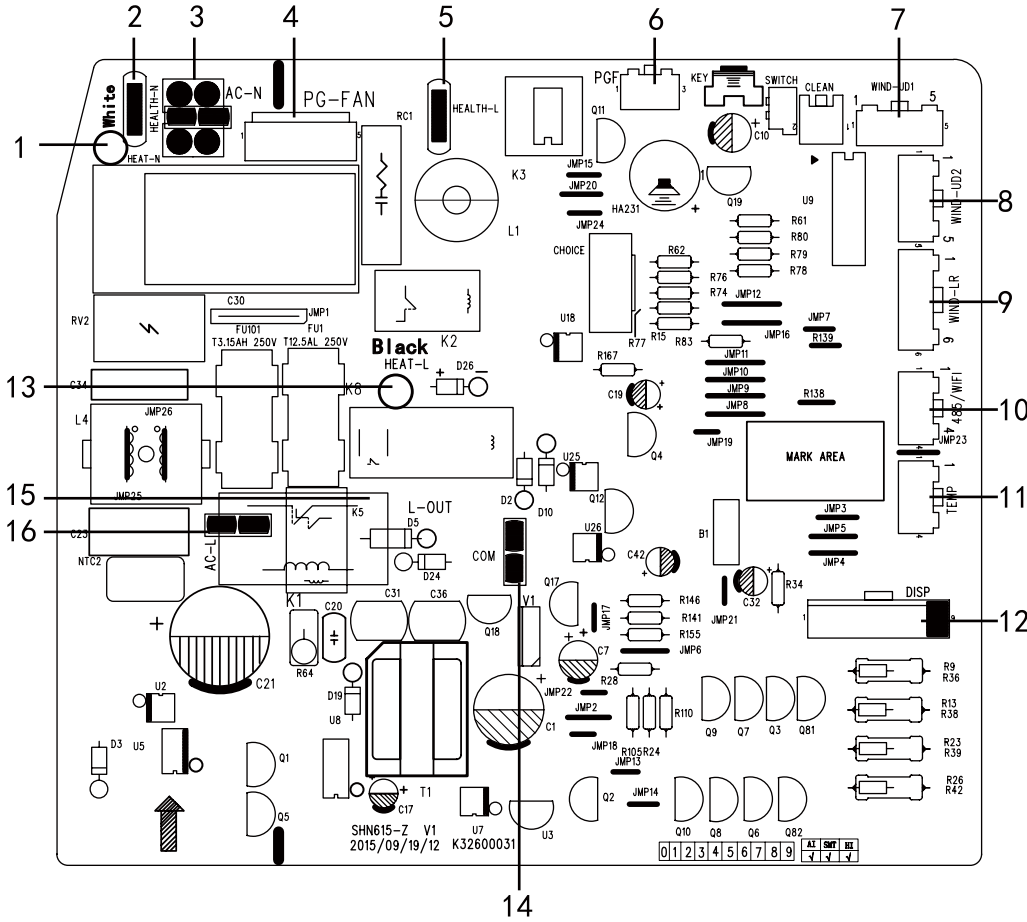

No.	Function
1	Auxiliary heating zero wire connector
2	Cold plasma zero wire connector
3	Power supply zero wire connector
4	AC motor connector
5	Cold plasma fire wire connector
6	AC motor feedback connector
7,8	Up and down louver motor connector
9	Left and right louver motor connector
10	WIFI
11	Sensor connector
12	Display connector
13	Auxiliary heating fire wire connector
14	Communication connector
15	Outdoor fire wire connector
16	Power supply fire wire connector

BOTTOM VIEW

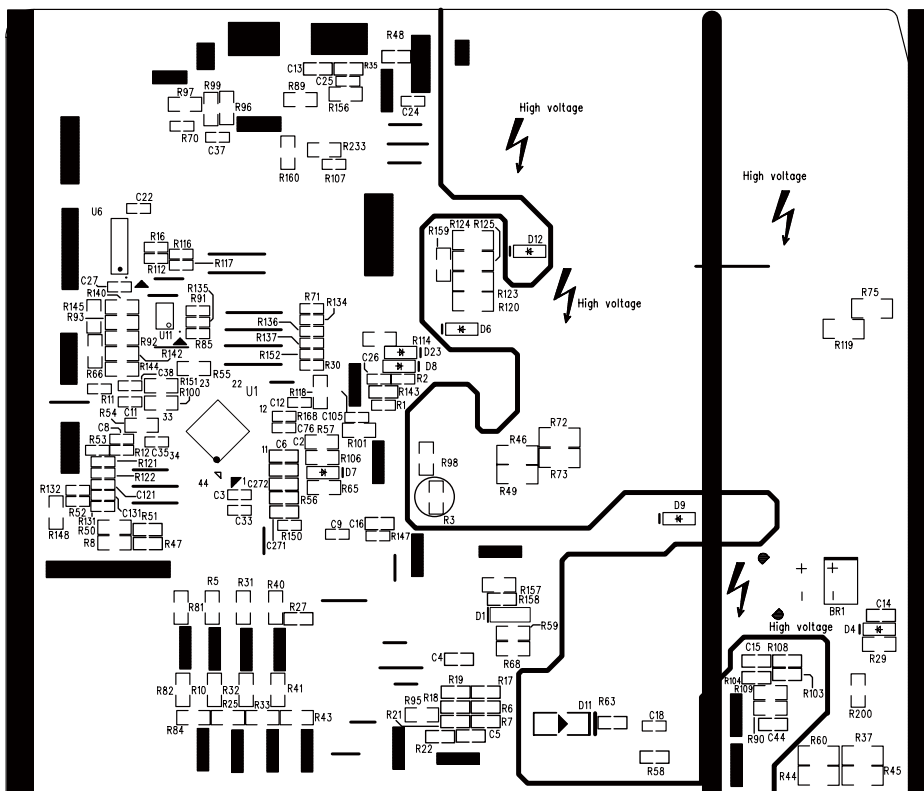

Outdoor Unit

Model: ICHV012I2A-YSI036.

- Top View

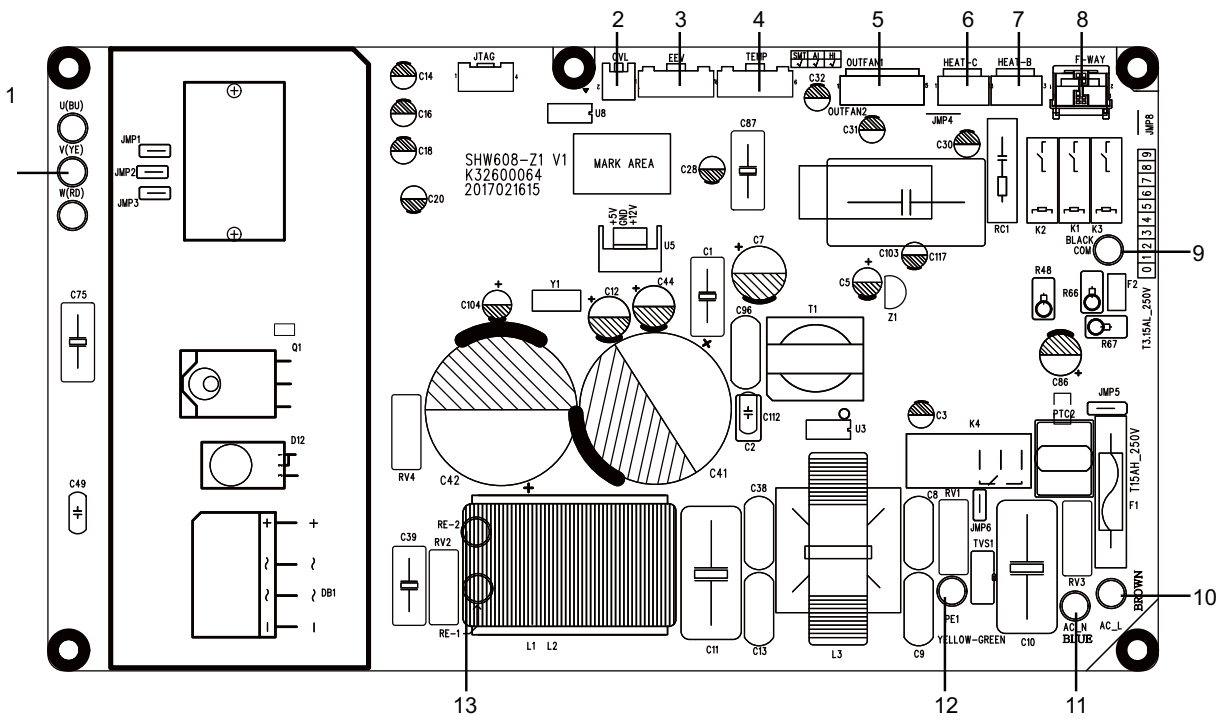
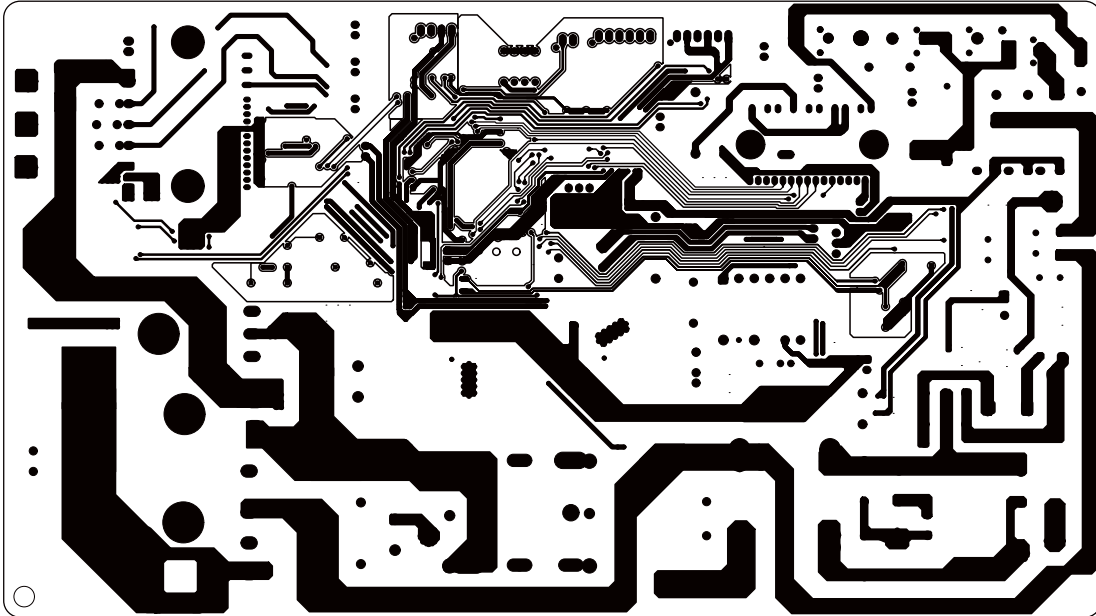

NO.	Silk screen name	Connector	Function note
1	U(BU), V(YE),W(RD)	Compressor interface	Used to connect the compressor: U (BU) - (YE) - yellow blue, V, W (RD) - red
2	OVL	Overload interface	Used to connect the compressor overload protector, the two white lines. Random selection
3	EEV	Electronic expansion valve interface	Used to connect five core electronic expansion valve
4	TEMP	Temp.sensor interface	Used to connect to the six core thermal package: tube temperature (20 k @ 25 °C), the outer ring temperature (15 k @ 25 °C), exhaust (50 k @ 25 °C)
5	OFAN,OFAN1	Fan interface	Used to connect to external fan
6	HEAT-C	Compression mechanical and electrical heated interface	Used to compress the mechanical and electrical heating zone
7	HEAT-B	Chassis electrical heating zone interface	Used for chassis electrical heating zone
8	F-WAY	4-way-valve interface	4-way-valve
9	COM	Communication line	Used to communicate with the indoor unit
10	AC-L	Power supply line	Used to connect to the power supply line
11	AC-N	Power supply wiring	Used to connect the power supply wiring
12	PE	Power supply ground line	Used to connect the power supply ground line
13	RE-1, RE-2	Reactor connecting	Used to connect the reactor

Model: ICHV018(24)I2A-YSH056(71)

● Top View

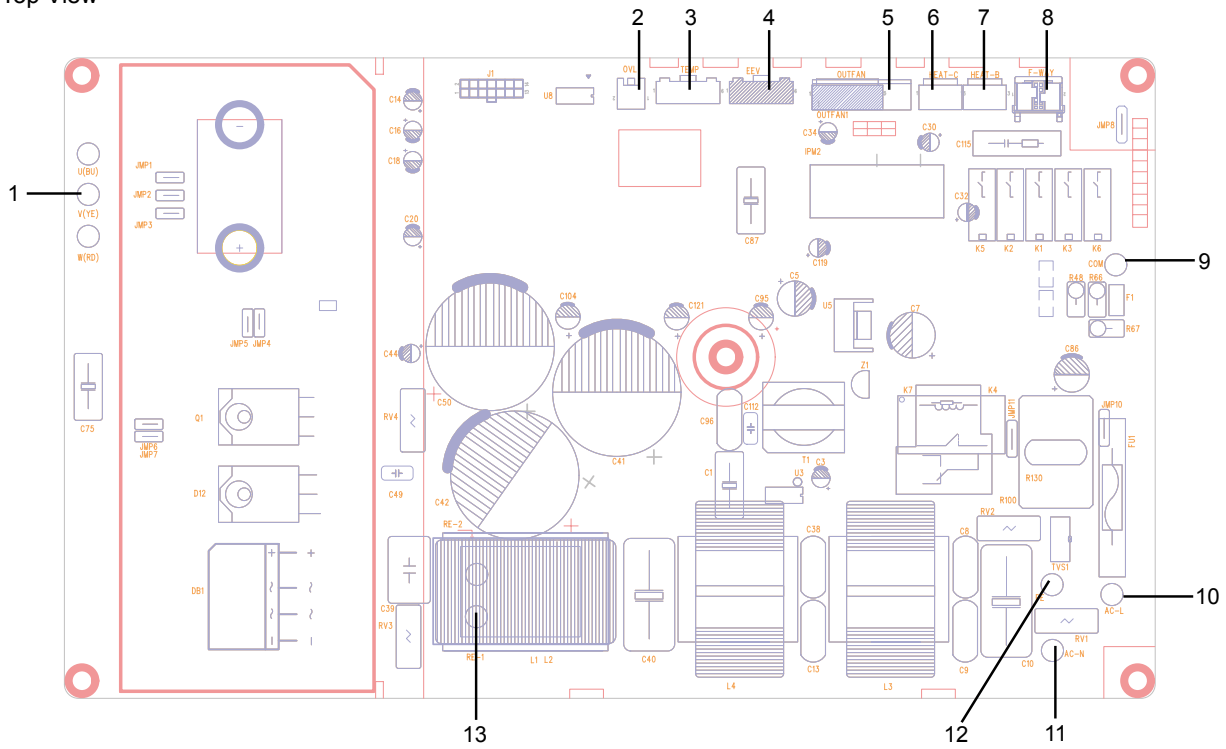

NO.	Silk screen name	Connector	Function note
1	U(BU), V(YE),W(RD)	Compressor interface	Used to connect the compressor: U (BU) - (YE) - yellow blue, V, W (RD) - red
2	OVL	Overload interface	Used to connect the compressor overload protector, the two white lines. Random selection
3	TEMP	Temp.sensor interface	Used to connect to the six core thermal package: tube temperature (20 k @ 25 °C), the outer ring temperature (15 k @ 25 °C), exhaust (50 k @ 25 °C)
4	EEV	Electronic expansion valve interface	Used to connect five core electronic expansion valve
5	OFAN,OFAN1	Fan interface	Used to connect to external fan
6	HEAT-C	Compression mechanical and electrical heated interface	Used to compress the mechanical and electrical heating zone
7	HEAT-B	Chassis electrical heating zone interface	Used for chassis electrical heating zone
8	F-WAY	4-way-valve interface	4-way-valve
9	COM	Communication line	Used to communicate with the indoor unit
10	AC-L	Power supply line	Used to connect to the power supply line
11	AC-N	Power supply wiring	Used to connect the power supply wiring
12	PE	Power supply ground line	Used to connect the power supply ground line
13	RE-1, RE-2	Reactor connecting	Used to connect the reactor

• Bottom View

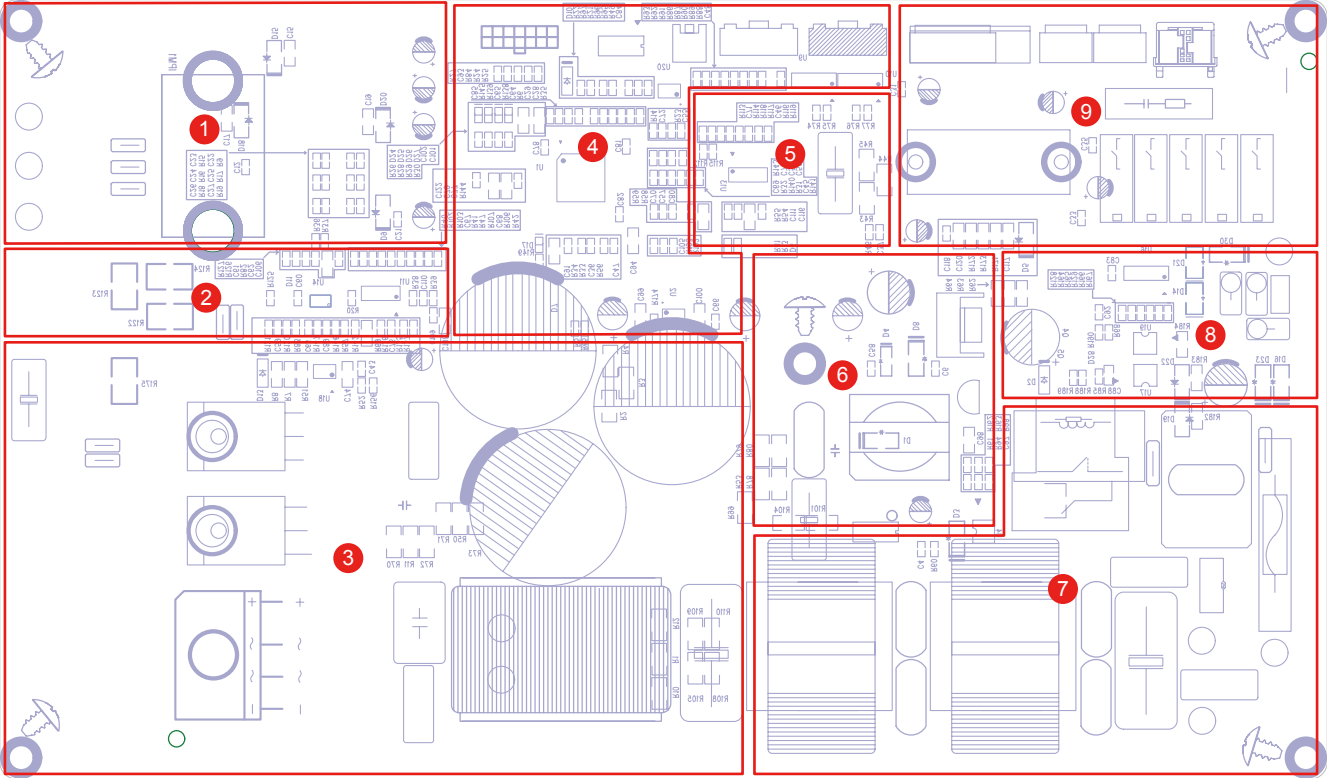

NO.	Name
1	Compressor control circuit
2	Compressor phase current sampling circuit & PFC current sampling circuit
3	Power factor correction (PFC) control circuit
4	Master control chip circuit
5	DC fan electric circuit, sampling circuit
6	Switch power supply circuit
7	EMI filter circuit
8	Wire communication circuit
9	Fan and load control circuit

1.3 Procedure of Troubleshooting

Indoor unit

(1) Malfunction of Temperature Sensor U0, U1

Main detection points:

- Is the wiring terminal between the temperature sensor and the controller loosened or poorly contacted?
- Is there short circuit due to trip-over of the parts?
- Is the temperature sensor broken?
- Is main board broken?Malfunction diagnosis process:

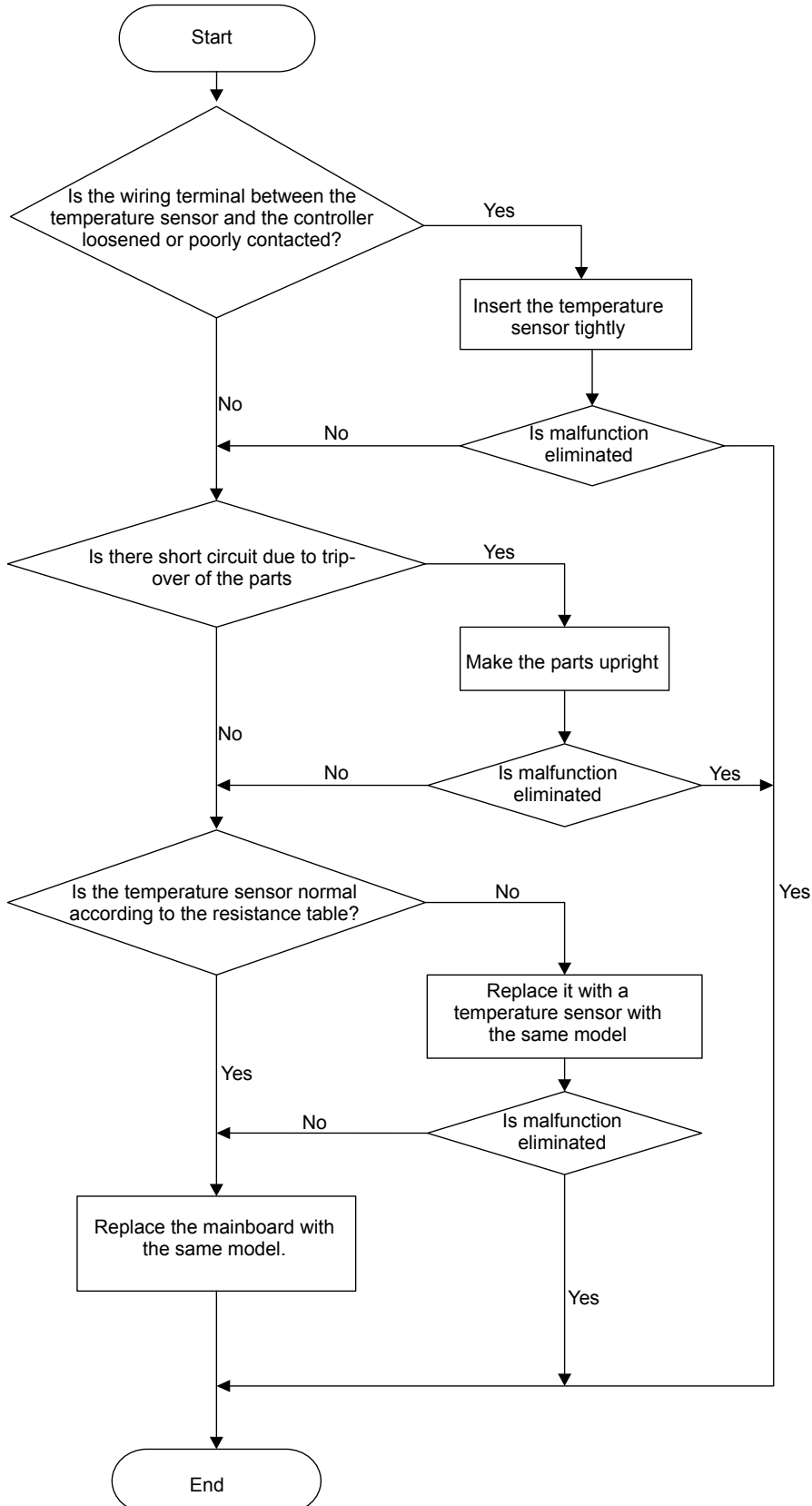

(2) Malfunction of Blocked Protection of IDU Fan Motor L2

Main detection points:

- Smoothly is the control terminal of PG motor connected tightly?
- Smoothly is the feedback interface of PG motor connected tightly?
- The fan motor can't operate?
- The motor is broken?
- Detection circuit of the mainboard is defined abnormal

Malfunction diagnosis process:

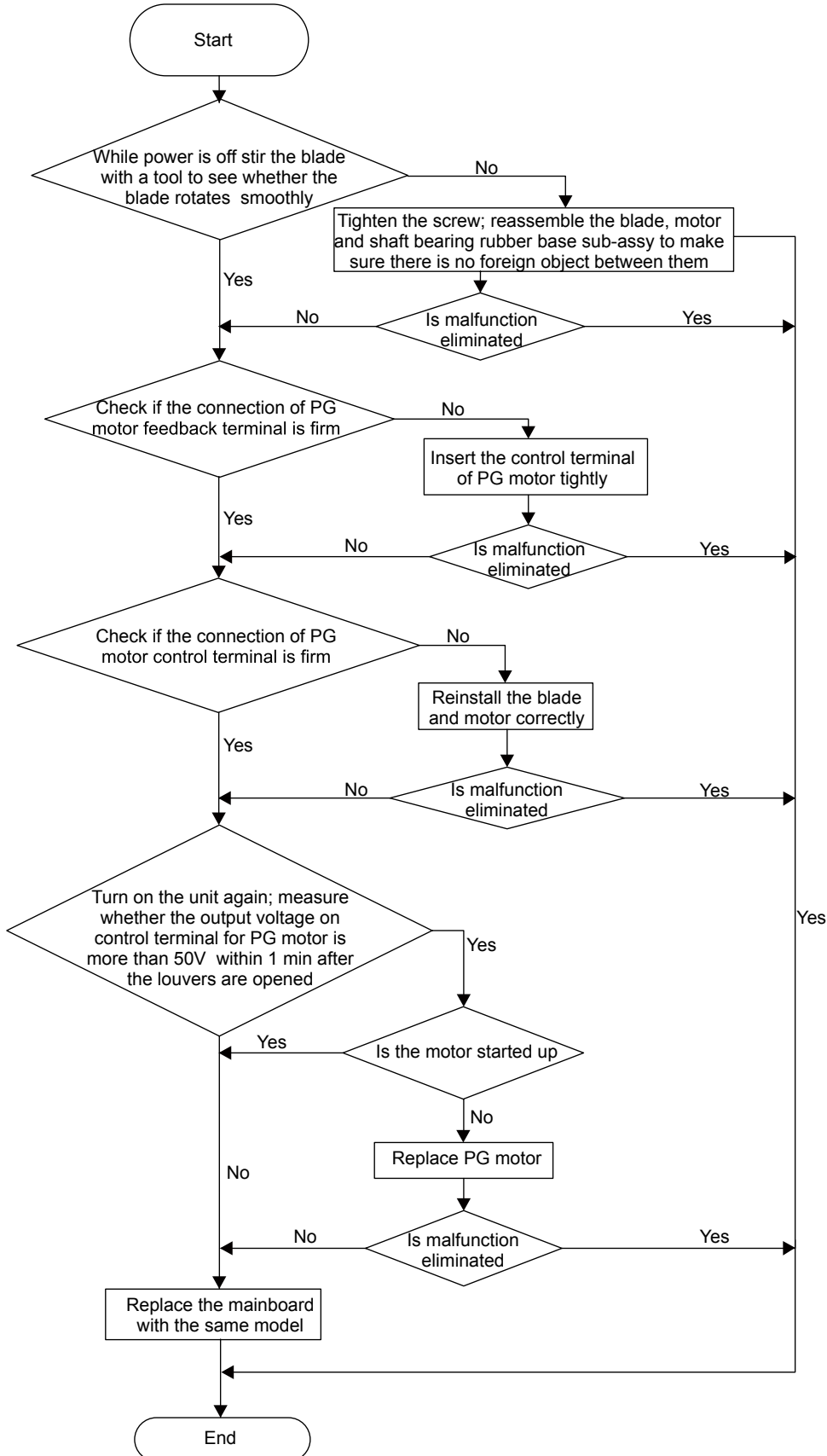

(3) Malfunction of Protection of Jumper Cap L0

Main detection points:

- Is there jumper cap on the main board?
- Is the jumper cap inserted correctly and tightly?
- The jumper is broken?
- The motor is broken?
- Detection circuit of the mainboard is defined abnormal.

Malfunction diagnosis process:

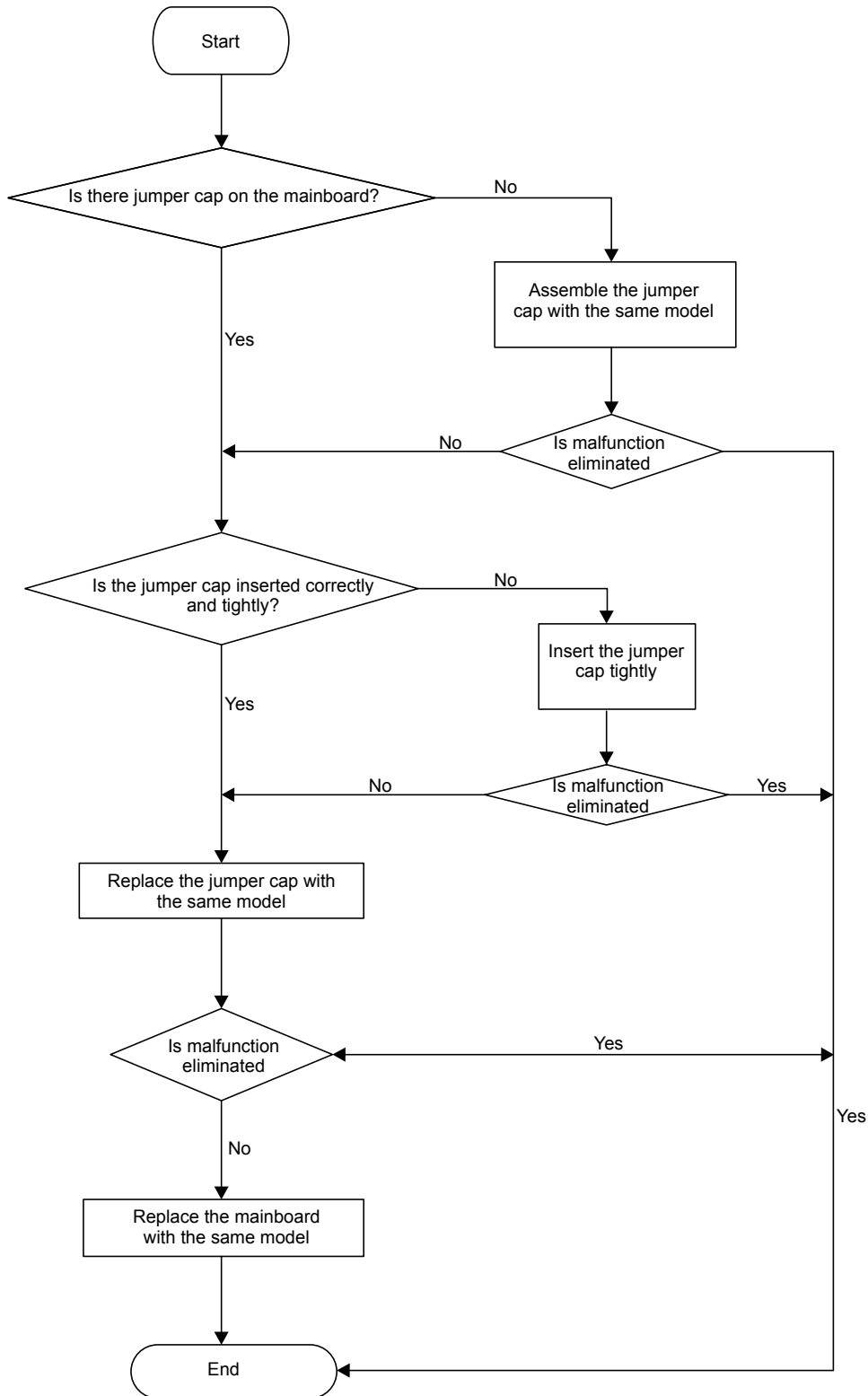

(4) Malfunction of Zero-crossing Inspection Circuit Malfunction of the IDU Fan Motor L1

Main detection points:

- Instant energization after de-energization while the capacitor discharges slowly?
- The zero-cross detection circuit of the mainboard is defined abnormal.

Malfunction diagnosis process:

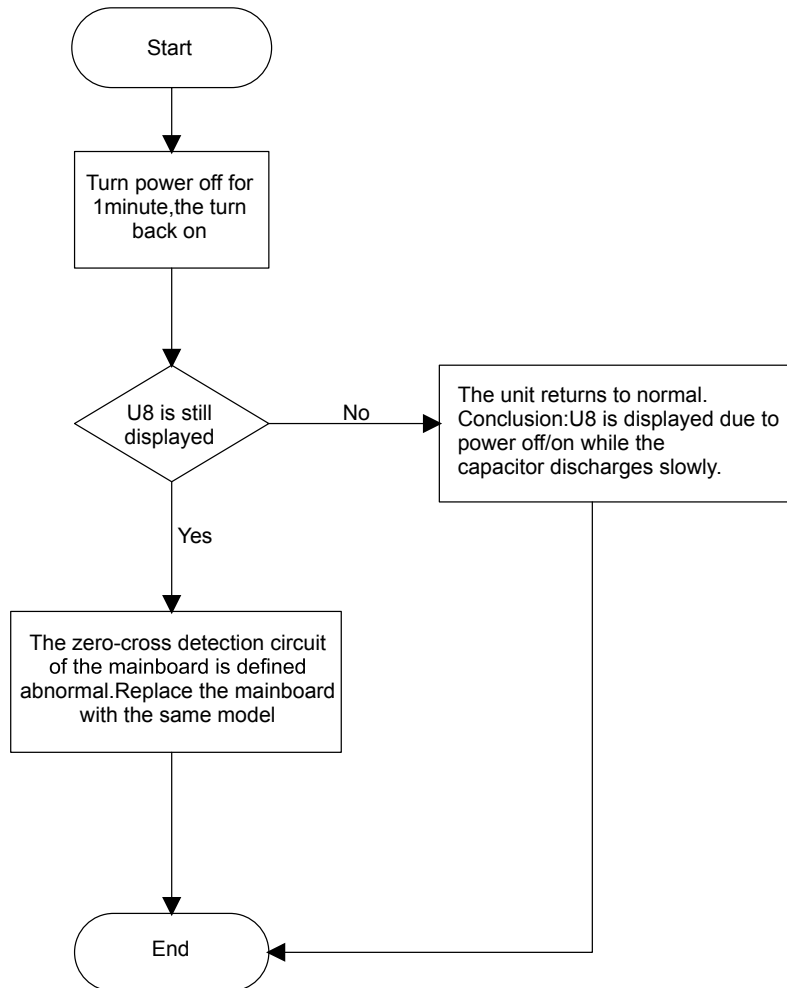

Outdoor unit:

(1) Capacitor charge fault (Fault with outdoor unit) (AP1 below refers to the outdoor control panel)

Main Check Points:

- Use AC voltmeter to check if the voltage between terminal L and N on the wiring board is within 210VAC~240VAC.
- Is the reactor (L) correctly connected? Is the connection loose or fallen? Is the reactor (L) damaged?

Fault diagnosis process:

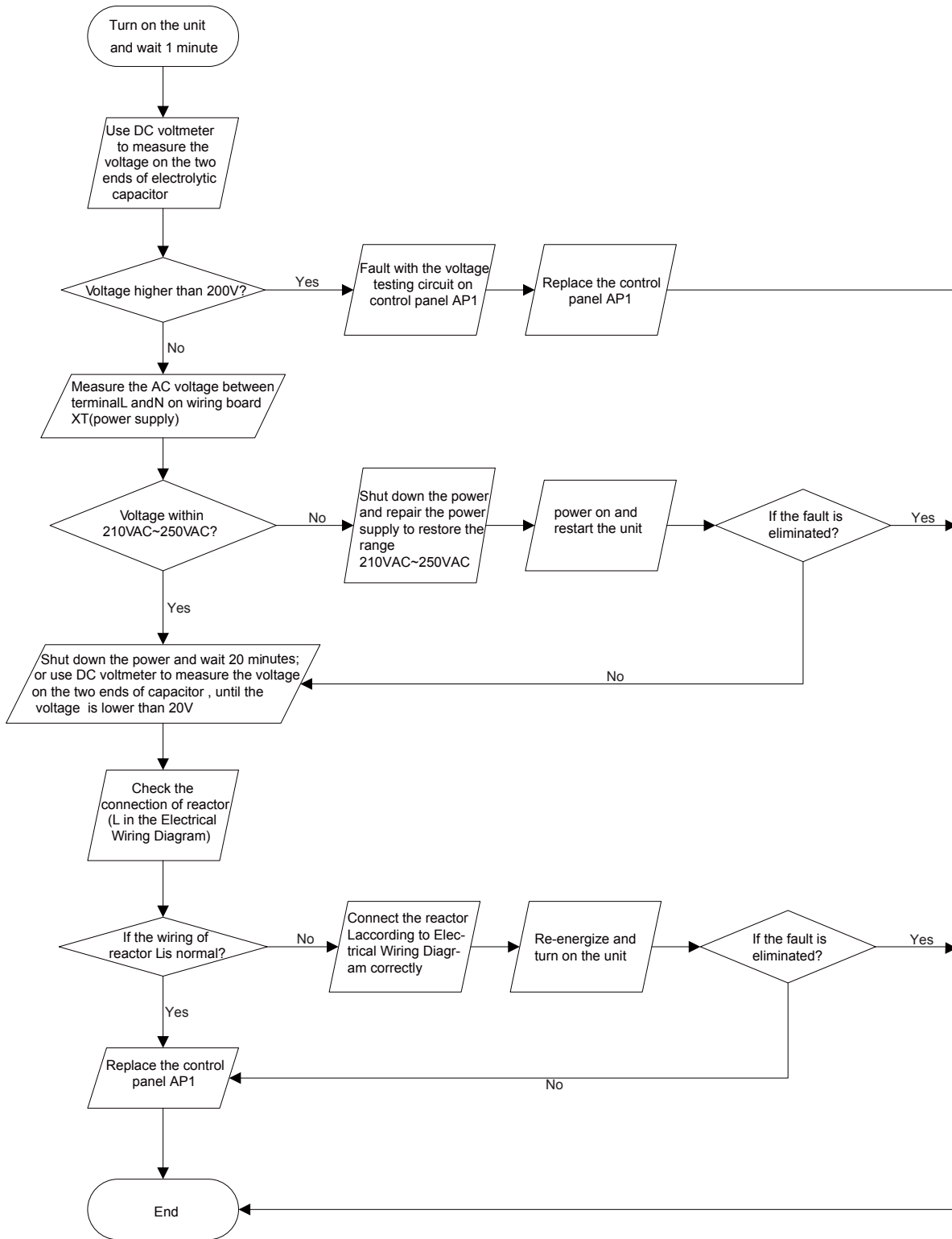

(2) IPM Protection , Out-of-step Fault , Compressor Phase Over current (AP1 below refers to the outdoor control panel)

Main check points:

- Is the connection between control panel AP1 and compressor COMP secure? Loose? Is the connection in correct order?
- Is the voltage input of the machine within normal range? (Use AC voltmeter to measure the voltage between terminal L and N on the wiring board XT)
- Is the compressor coil resistance normal? Is the insulation of compressor coil against the copper tube in good condition?
- Is the working load of the machine too high? Is the radiation good?
- Is the charge volume of refrigerant correct?

Fault diagnosis process:

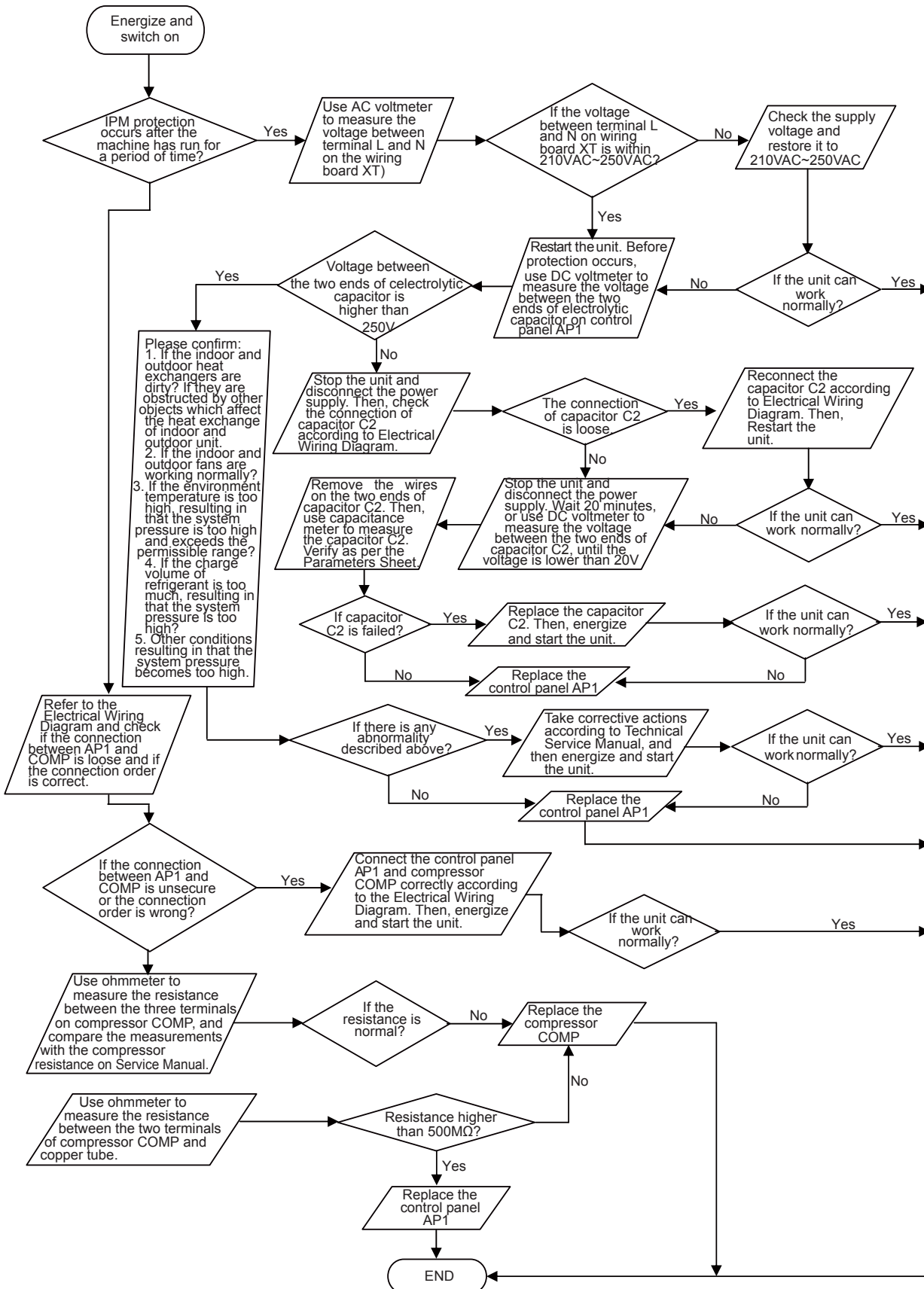

(3) High temperature and overload protection diagnosis (AP1 hereinafter refers to the control board of the outdoor unit)

Mainly detect:

- Is outdoor ambient temperature in normal range?
- Are the outdoor and indoor fans operating normally?
- Is the heat dissipation environment inside and outside the unit good?

Fault diagnosis process:

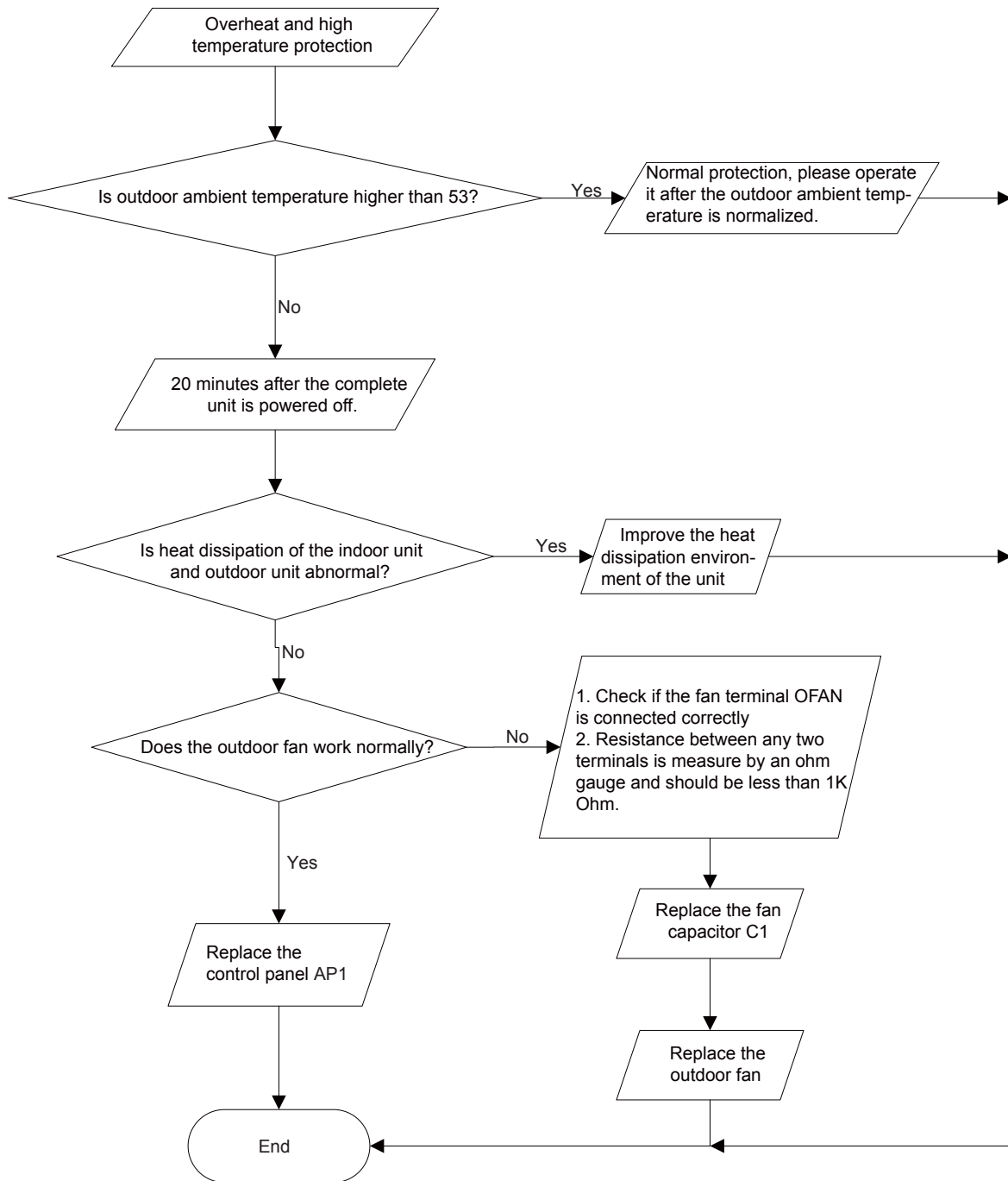

(4) Start-up failure (following AP1 for outdoor unit control board)

Mainly detect:

- Whether the compressor wiring is connected correct?
- Is compressor broken?
- Is time for compressor stopping enough?

Fault diagnosis process:

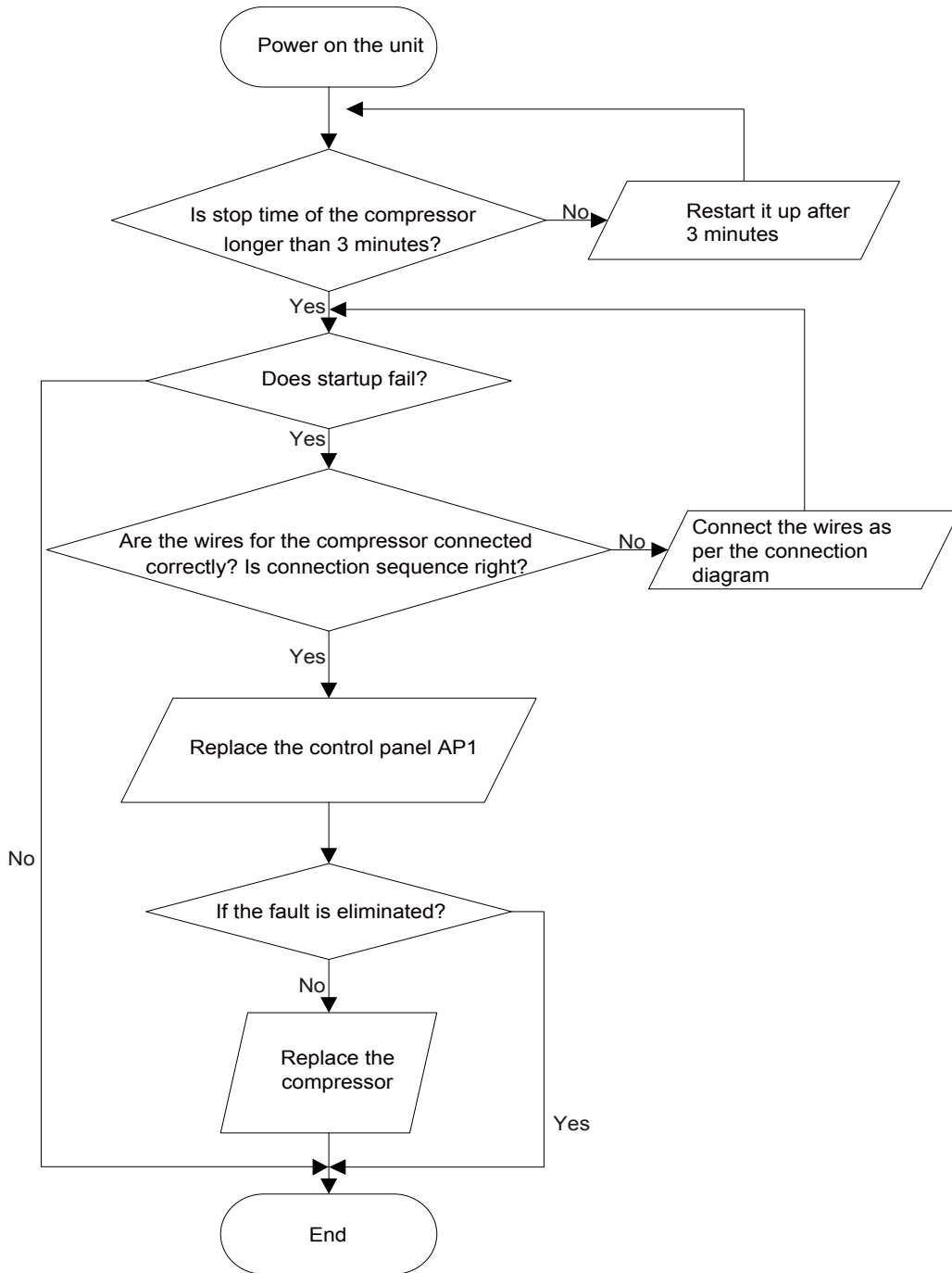

(5) Out of step diagnosis for the compressor (AP1 here in after refers to the control board of the outdoor unit)

Mainly detect:

- Is the system pressure too high?
- Is the input voltage too low?

Fault diagnosis process:

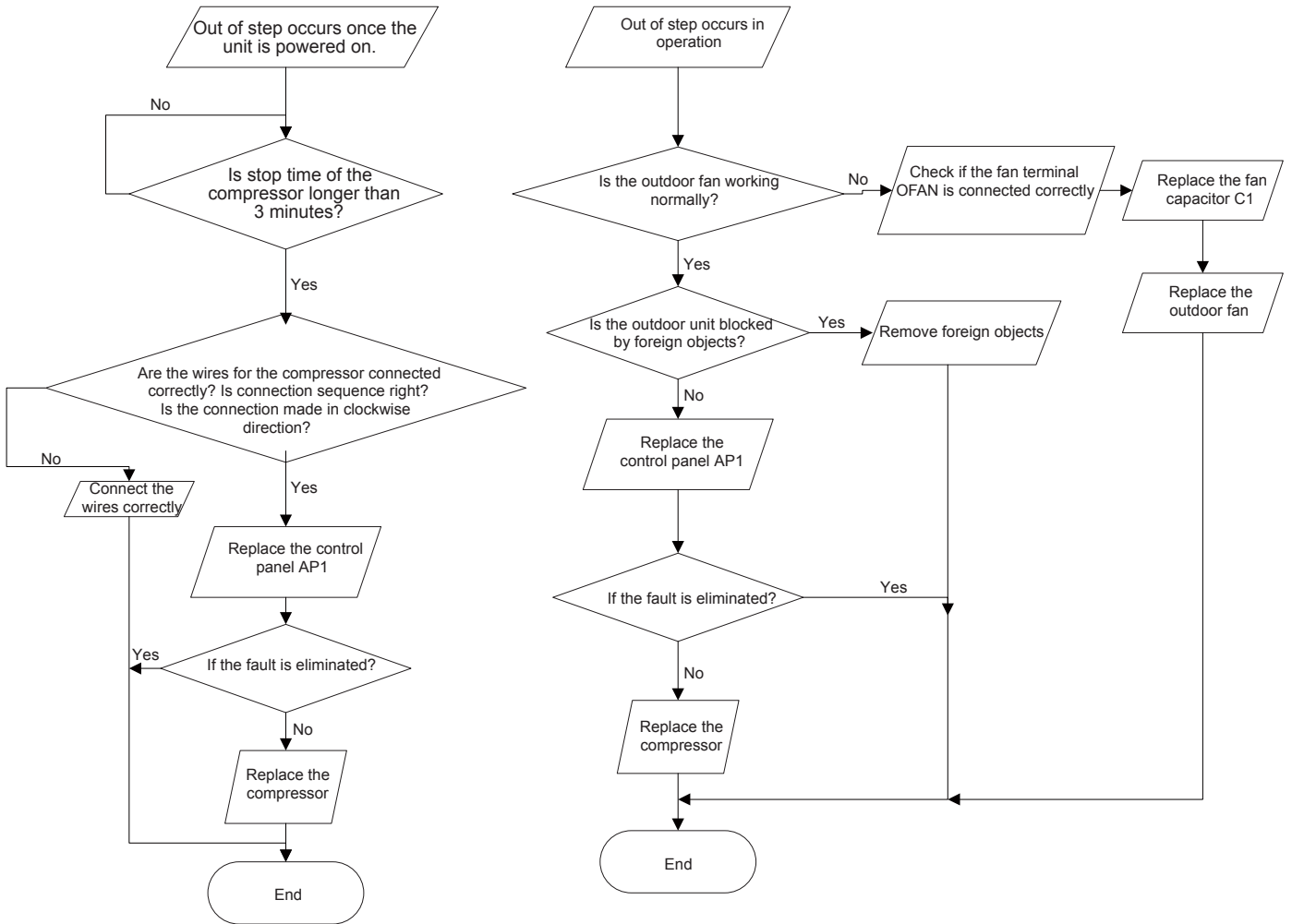

(6) Overload and air exhaust malfunction diagnosis (following AP1 for outdoor unit control board)

Mainly detect:

- Is the PMV connected well or not? Is PMV damaged?
- Is refrigerant leaked?

Fault diagnosis process:

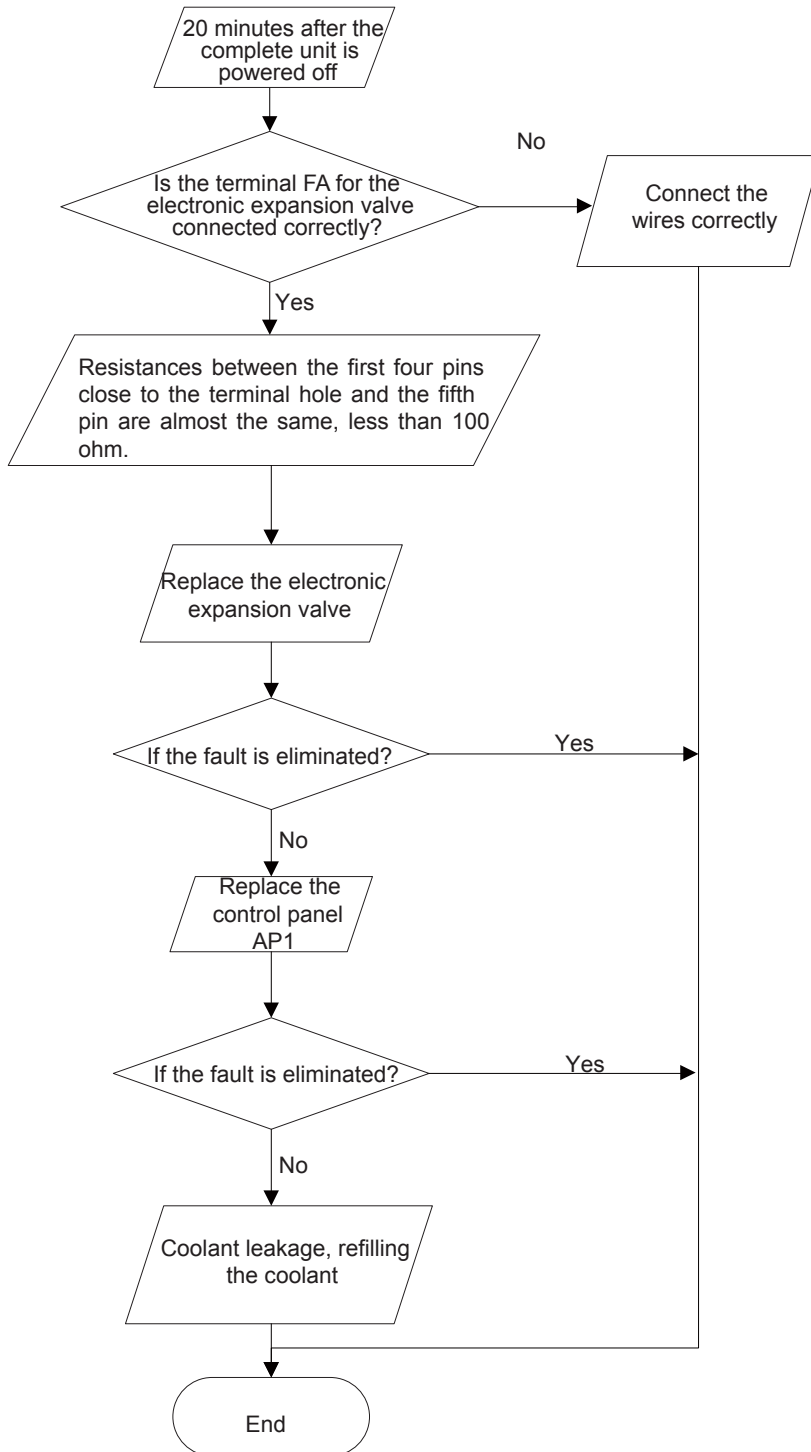

(7) Power factor correct (PFC) fault P9 (a fault of outdoor unit) (AP1 here in after refers to the control board of the outdoor unit)

Mainly detect:

- Check if the reactor (L) of the outdoor unit and the PFC capacitor are broken.

Fault diagnosis process:

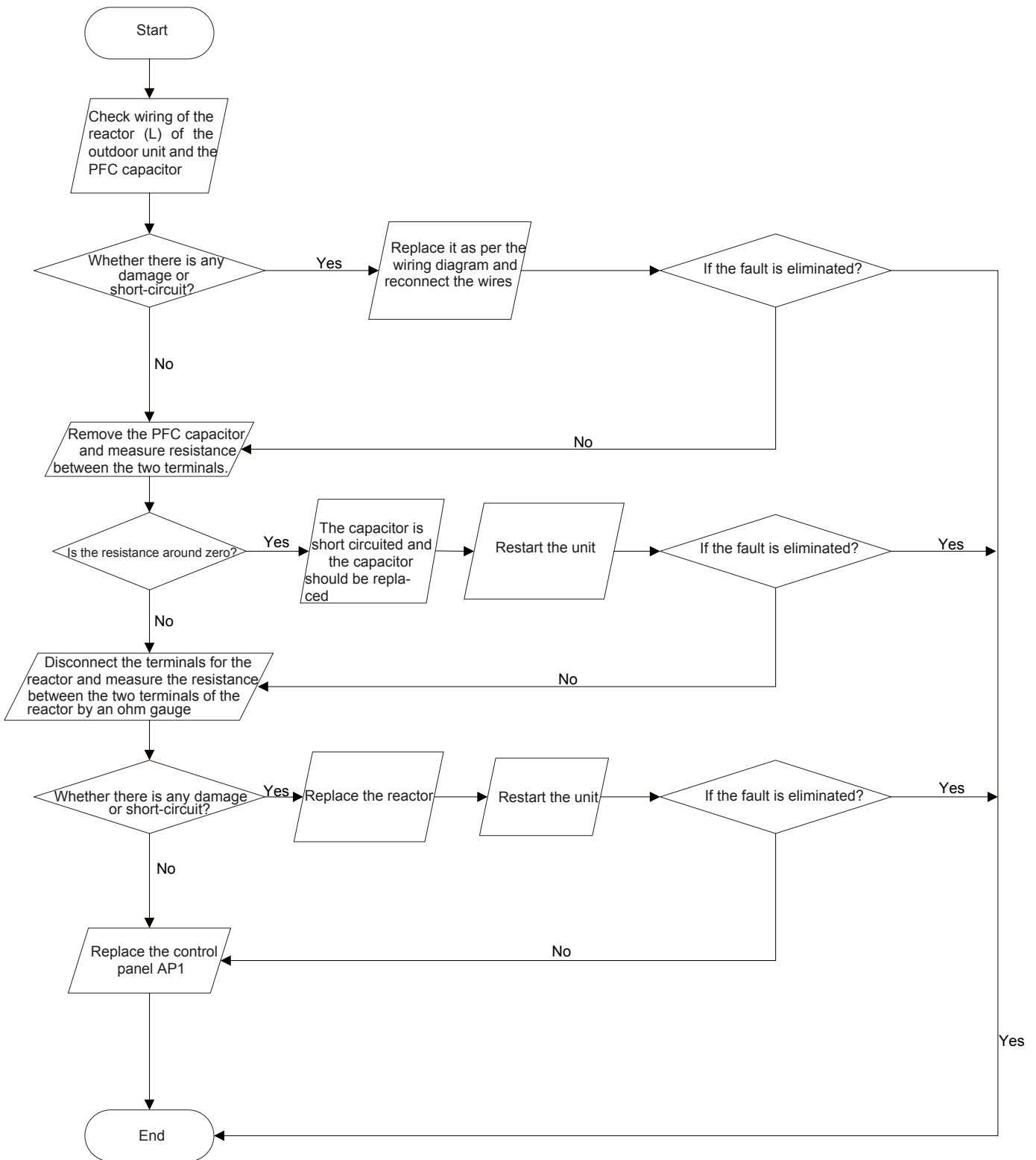

(8) Communication malfunction (following AP1 for outdoor unit control board)

Mainly detect:

- Is there any damage for the indoor unit main board communication circuit? Is communication circuit damaged?
- Detect the indoor and outdoor units connection wire and indoor and outdoor units inside wiring is connect well or not, if is there any damage?

Fault diagnosis process:

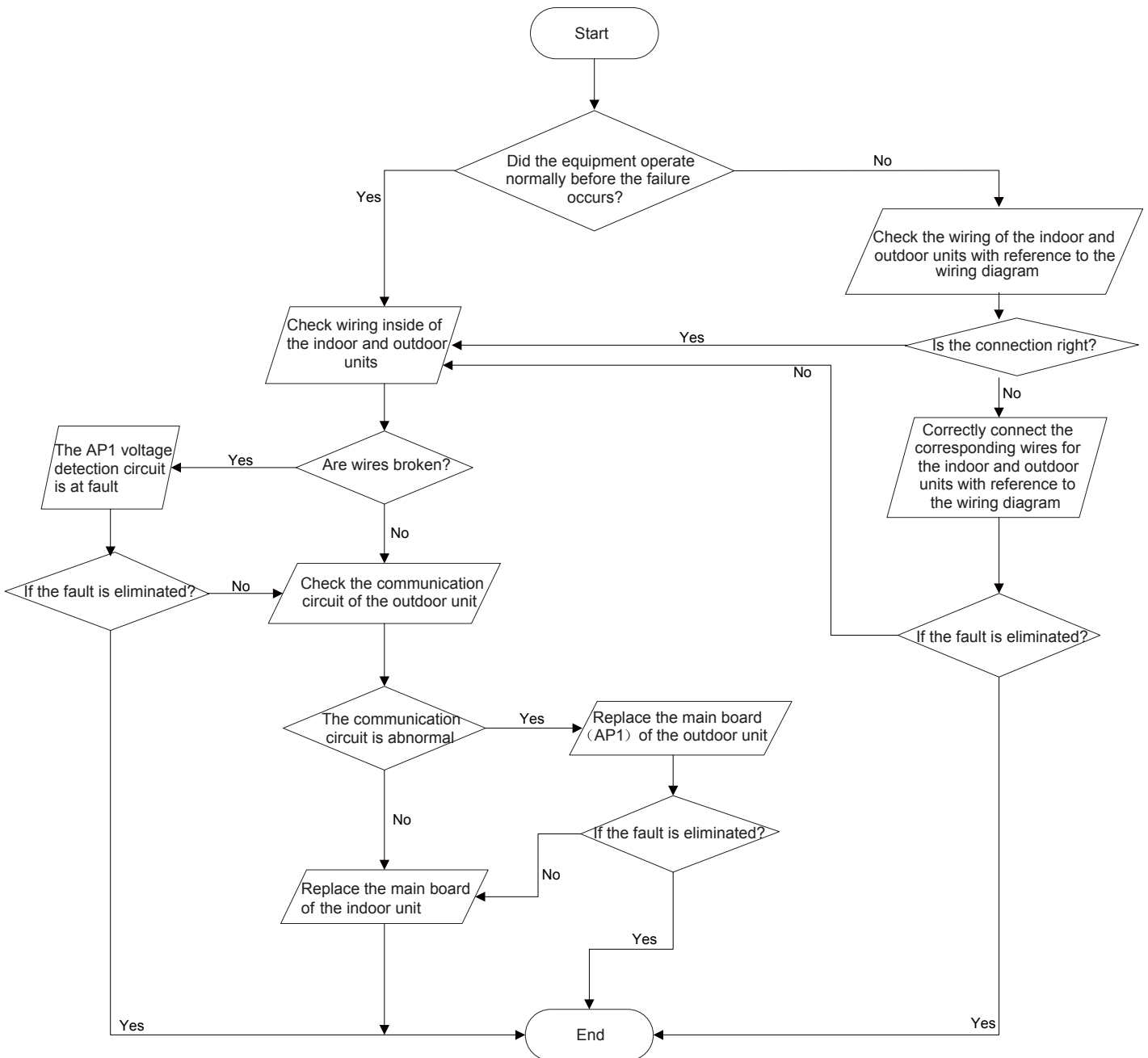

(9) Malfunction of Overcurrent Protection

Main detection points:

- Is the supply voltage unstable with big fluctuation.
- Is the supply voltage too low with overload?
- Hardware trouble?

Malfunction diagnosis process:

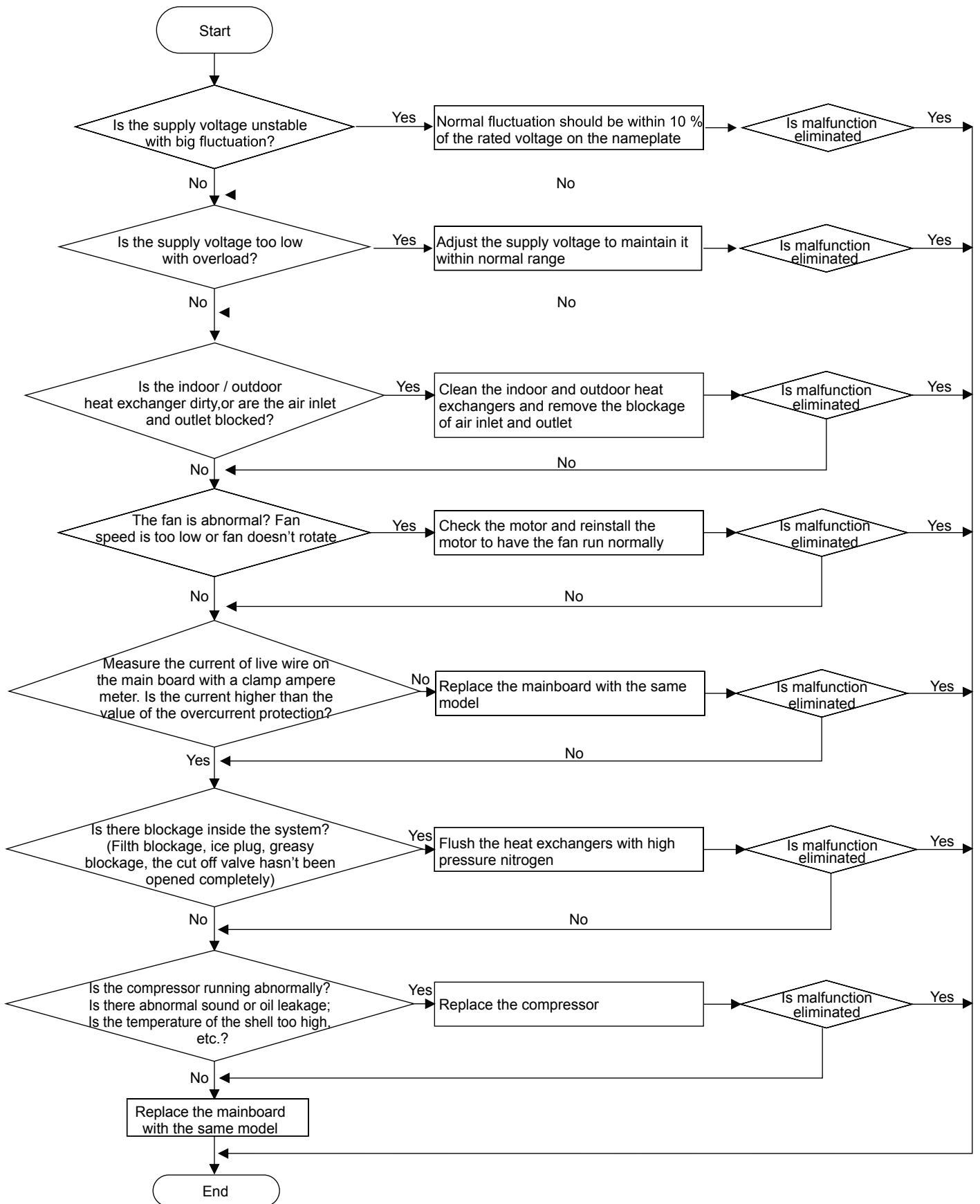

1.4 Troubleshooting for Normal Malfunction

1. Air Conditioner Can't be Started Up

Possible Causes	Discriminating Method (Air conditioner Status)	Troubleshooting
No power supply, or poor connection for power plug	After energization, operation indicator isn't bright and the buzzer can't give out sound	Confirm whether it's due to power failure. If yes, wait for power recovery. If not, check power supply circuit and make sure the power plug is connected well.
Wrong wire connection between indoor unit and outdoor unit, or poor connection for wiring terminals	Under normal power supply circumstances, operation indicator isn't bright after energization	Check the circuit according to circuit diagram and connect wires correctly. Make sure all wiring terminals are connected firmly
Electric leakage for air conditioner	After energization, room circuit breaker trips off at once	Make sure the air conditioner is grounded reliably. Make sure wires of air conditioner is connected correctly. Check the wiring inside air conditioner. Check whether the insulation layer of power cord is damaged; if yes, place the power cord
Model selection for air switch is improper	After energization, air switch trips off	Select proper air switch
Malfunction of remote controller	After energization, operation indicator is bright, while no display on remote controller or buttons have no action	Replace batteries for remote controller Repair or replace remote controller

2. Poor Cooling (Heating) for Air Conditioner

Possible Causes	Discriminating Method (Air conditioner Status)	Troubleshooting
Set temperature is improper	Observe the set temperature on remote controller	Adjust the set temperature
Rotation speed of the IDU fan motor is set too low	Small wind blow	Set the fan speed at high or medium
Filter of indoor unit is blocked	Check the filter to see it's blocked	Clean the filter
Installation position for indoor unit and outdoor unit is improper	Check whether the installation position is proper according to installation requirement for air conditioner	Adjust the installation position, and install the rainproof and sunproof for outdoor unit
Refrigerant is leaking	Discharged air temperature during cooling is higher than normal discharged wind temperature; Discharged air temperature during heating is lower than normal discharged wind temperature; Unit's pressure is much lower than regulated range	Find out the leakage causes and deal with it. Add refrigerant.
Malfunction of 4-way valve	Blow cold wind during heating	Replace the 4-way valve
Malfunction of capillary	Discharged air temperature during cooling is higher than normal discharged wind temperature; Discharged air temperature during heating is lower than normal discharged wind temperature; Unit's pressure is much lower than regulated range. If refrigerant isn't leaking, part of capillary is blocked	Replace the capillary
Flow volume of valve is insufficient	The pressure of valves is much lower than that stated in the specification	Open the valve completely
Malfunction of horizontal louver	Horizontal louver can't swing	Refer to point 3 of maintenance method for details
Malfunction of the IDU fan motor	The IDU fan motor can't operate	Refer to troubleshooting for H6 for maintenance method in details
Malfunction of the ODU fan motor	The ODU fan motor can't operate	Refer to point 4 of maintenance method for details
Malfunction of compressor	Compressor can't operate	Refer to point 5 of maintenance method for details

3. Horizontal Louver Can't Swing

Possible Causes	Discriminating Method (Air conditioner Status)	Troubleshooting
Wrong wire connection, or poor connection	Check the wiring status according to circuit diagram	Connect wires according to wiring diagram to make sure all wiring terminals are connected firmly
Stepping motor is damaged	Stepping motor can't operate	Repair or replace stepping motor
Main board is damaged	Others are all normal, while horizontal louver can't operate	Replace the main board with the same model

4. ODU Fan Motor Can't Operate

Possible Causes	Discriminating Method (Air conditioner Status)	Troubleshooting
Wrong wire connection, or poor connection	Check the wiring status according to circuit diagram	Connect wires according to wiring diagram to make sure all wiring terminals are connected firm!
Capacity of the ODU fan motor is damaged	Measure the capacity of fan capacitor with an universal meter and find that the capacity is out of the deviation range indicated on the nameplate of fan capacitor.	Replace the capacity of fan
Power voltage is a little low or high	Use universal meter to measure the power supply voltage. The voltage is a little high or low	Suggest to equip with voltage regulator
Motor of outdoor unit is damaged	When unit is on, cooling/heating performance is bad and ODU compressor generates a lot of noise and heat.	Change compressor oil and refrigerant. If no better, replace the compressor with a new one

5. Compressor Can't Operate

Possible Causes	Discriminating Method (Air conditioner Status)	Troubleshooting
Wrong wire connection, or poor connection	Check the wiring status according to circuit diagram	Connect wires according to wiring diagram to make sure all wiring terminals are connected firm!
Capacity of compressor is damaged	Measure the capacity of fan capacitor with an universal meter and find that the capacity is out of the deviation range indicated on the nameplate of fan capacitor.	Replace the compressor capacitor
Power voltage is a little low or high	Use universal meter to measure the power supply voltage. The voltage is a little high or low	Suggest to equip with voltage regulator
Coil of compressor is burnt out	Use universal meter to measure the resistance between compressor terminals and it's 0	Repair or replace compressor
Cylinder of compressor is blocked	Compressor can't operate	Repair or replace compressor

6. Air Conditioner is Leaking

Possible Causes	Discriminating Method (Air conditioner Status)	Troubleshooting
Drain pipe is blocked	Water leaking from indoor unit	Eliminate the foreign objects inside the drain pipe
Drain pipe is broken	Water leaking from drain pipe	Replace drain pipe
Wrapping is not tight	Water leaking from the pipe connection place of indoor unit	Wrap it again and bundle it tightly

7. Abnormal Sound and Vibration

Possible Causes	Discriminating Method (Air conditioner Status)	Troubleshooting
When turn on or turn off the unit, the panel and other parts will expand and there's abnormal sound	There's the sound of "PAPA"	Normal phenomenon. Abnormal sound will disappear after a few minutes.
When turn on or turn off the unit, there's abnormal sound due to flow of refrigerant inside air conditioner	Water-running sound can be heard	Normal phenomenon. Abnormal sound will disappear after a few minutes.
Foreign objects inside the indoor unit or there're parts touching together inside the indoor unit	There's abnormal sound from indoor unit	Remove foreign objects. Adjust all parts' position of indoor unit, tighten screws and stick damping plaster between connected parts
Foreign objects inside the outdoor unit or there're parts touching together inside the outdoor unit	There's abnormal sound from outdoor unit	Remove foreign objects. Adjust all parts' position of outdoor unit, tighten screws and stick damping plaster between connected parts
Short circuit inside the magnetic coil	During heating, the way valve has abnormal electromagnetic sound	Replace magnetic coil
Abnormal shake of compressor	Outdoor unit gives out abnormal sound	Adjust the support foot mat of compressor, tighten the bolts
Abnormal sound inside the compressor	Abnormal sound inside the compressor	If add too much refrigerant during maintenance, please reduce refrigerant properly. Replace compressor for other circumstances.

Appendix1:Resistance Table for Indoor and Outdoor Ambient Temperature Sensors (15K)

Temp.(°C)	Resistance(kΩ)	Temp.(°C)	Resistance(kΩ)	Temp.(°C)	Resistance(kΩ)	Temp.(°C)	Resistance(kΩ)
-20	144	16	22.53	52	4.986	88	1.451
-19	138.1	17	21.51	53	4.802	89	1.408
-18	128.6	18	20.54	54	4.625	90	1.363
-17	121.6	19	19.63	55	4.456	91	1.322
-16	115	20	18.75	56	4.294	92	1.282
-15	108.7	21	17.93	57	4.139	93	1.244
-14	102.9	22	17.14	58	3.99	94	1.207
-13	97.4	23	16.39	59	3.848	95	1.171
-12	92.22	24	15.68	60	3.711	96	1.136
-11	87.35	25	15	61	3.579	97	1.103
-10	82.75	26	14.36	62	3.454	98	1.071
-9	78.43	27	13.74	63	3.333	99	1.039
-8	74.35	28	13.16	64	3.217	100	1.009
-7	70.5	29	12.6	65	3.105	101	0.9801
-6	66.88	30	12.07	66	2.998	102	0.9519
-5	63.46	31	11.57	67	2.898	103	0.9247
-4	60.23	32	11.09	68	2.797	104	0.8984
-3	57.18	33	10.63	69	2.702	105	0.873
-2	54.31	34	10.2	70	2.611	106	0.8484
-1	51.59	35	9.779	71	2.523	107	0.8246
0	49.02	36	9.382	72	2.439	108	0.8016
1	46.8	37	9.003	73	2.358	109	0.7793
2	44.31	38	8.642	74	2.28	110	0.7577
3	42.14	39	8.297	75	2.205	111	0.7369
4	40.09	40	7.967	76	2.133	112	0.7167
5	38.15	41	7.653	77	2.064	113	0.6971
6	36.32	42	7.352	78	1.997	114	0.6782
7	34.58	43	7.065	79	1.933	115	0.6599
8	32.94	44	6.791	80	1.871	116	0.6421
9	31.38	45	6.529	81	1.811	117	0.625
10	29.9	46	6.278	82	1.754	118	0.6083
11	28.51	47	6.038	83	1.699	119	0.5922
12	27.18	48	5.809	84	1.645	120	0.5765
13	25.92	49	5.589	85	1.594	121	0.5614
14	24.73	50	5.379	86	1.544	122	0.5467
15	23.6	51	5.179	87	1.497	123	0.5324

Appendix2:ResistanceTable for Indoor and Outdoor Ambient Temperature Sensors (20K)

Temp.(°C)	Resistance(kΩ)	Temp.(°C)	Resistance(kΩ)	Temp.(°C)	Resistance(kΩ)	Temp.(°C)	Resistance(kΩ)
-30	361.8	6	48.42	42	9.803	78	2.663
-29	339.8	7	46.11	43	9.42	79	2.577
-28	319.2	8	43.92	44	9.054	80	2.495
-27	300	9	41.84	45	8.705	81	2.415
-26	282.2	10	39.87	46	8.37	82	2.339
-25	265.5	11	38.01	47	8.051	83	2.265
-24	249.9	12	36.24	48	7.745	84	2.194
-23	235.3	13	34.57	49	7.453	85	2.125
-22	221.6	14	32.98	50	7.173	86	2.059
-21	208.9	15	31.47	51	6.905	87	1.996
-20	196.9	16	30.04	52	6.648	88	1.934
-19	181.4	17	28.68	53	6.403	89	1.875
-18	171.4	18	27.39	54	6.167	90	1.818
-17	162.1	19	26.17	55	5.942	91	1.763
-16	153.3	20	25.01	56	5.726	92	1.71
-15	145	21	23.9	57	5.519	93	1.658
-14	137.2	22	22.85	58	5.32	94	1.609
-13	129.9	23	21.85	59	5.13	95	1.561
-12	123	24	20.9	60	4.948	96	1.515
-11	116.5	25	20	61	4.773	97	1.47
-10	110.3	26	19.14	62	4.605	98	1.427
-9	104.6	27	18.32	63	4.443	99	1.386
-8	99.13	28	17.55	64	4.289	100	1.346
-7	94	29	16.8	65	4.14	101	1.307
-6	89.17	30	16.1	66	3.998	102	1.269
-5	84.61	31	15.43	67	3.861	103	1.233
-4	80.31	32	14.79	68	3.729	104	1.198
-3	76.24	33	14.18	69	3.603	105	1.164
-2	72.41	34	13.59	70	3.481	106	1.131
-1	68.79	35	13.04	71	3.364	107	1.099
0	65.37	36	12.51	72	3.252	108	1.069
1	62.13	37	12	73	3.144	109	1.039
2	59.08	38	11.52	74	3.04	110	1.01
3	56.19	39	11.06	75	2.94	111	0.9825
4	53.46	40	10.62	76	2.844	112	0.9556
5	50.87	41	10.2	77	2.752	113	0.9295

Appendix 3: Resistance Table for Indoor and Outdoor Ambient Temperature Sensors (50K)

Temp. (°C)	Resistance (kΩ)	Temp. (°C)	Resistance (kΩ)	Temp. (°C)	Resistance (kΩ)	Temp. (°C)	Resistance (kΩ)	Temp. (°C)	Resistance (kΩ)
-30	911.56	6	119.08	42	24.128	78	6.542	114	2.2409
-29	853.66	7	113.37	43	23.186	79	6.3315	115	2.1816
-28	799.98	8	107.96	44	22.286	80	6.1288	116	2.1242
-27	750.18	9	102.85	45	21.425	81	5.9336	117	2.0686
-26	703.92	10	98.006	46	20.601	82	5.7457	118	2.0148
-25	660.93	11	93.42	47	19.814	83	5.5647	119	1.9626
-24	620.94	12	89.075	48	19.061	84	5.3903	120	1.9123
-23	583.72	13	84.956	49	18.34	85	5.2223	121	1.8652
-22	549.04	14	81.052	50	17.651	86	5.0605	122	1.8158
-21	516.71	15	77.349	51	16.99	87	4.9044	123	1.7698
-20	486.55	16	73.896	52	16.358	88	4.7541	124	1.7253
-19	458.4	17	70.503	53	15.753	89	4.6091	125	1.6821
-18	432.1	18	67.338	54	15.173	90	4.4693	126	1.6402
-17	407.51	19	64.333	55	14.018	91	4.3345	127	1.5996
-16	384.51	20	61.478	56	14.085	92	4.2044	128	1.5602
-15	362.99	21	58.766	57	13.575	93	4.0789	129	1.522
-14	342.83	22	56.189	58	13.086	94	3.9579	130	1.485
-13	323.94	23	53.738	59	12.617	95	3.841	131	1.449
-12	306.23	24	51.408	60	12.368	96	3.7283	132	1.4141
-11	289.61	25	49.191	61	11.736	97	3.6194	133	1.3803
-10	274.02	26	47.082	62	11.322	98	3.5143	134	1.3474
-9	259.37	27	45.074	63	10.925	99	3.4128	135	1.3155
-8	245.61	28	43.163	64	10.544	100	3.3147	136	1.2846
-7	232.67	29	41.313	65	10.178	101	3.22	137	1.2545
-6	220.5	30	39.61	66	9.8269	102	3.1285	138	1.2233
-5	209.05	31	37.958	67	9.4896	103	3.0401	139	1.1969
-4	198.27	32	36.384	68	9.1655	104	2.9547	140	1.1694
-3	188.12	33	34.883	69	8.9542	105	2.8721	141	1.1476
-2	178.65	34	33.453	70	8.5551	106	2.7922	142	1.1166
-1	169.68	35	32.088	71	8.2676	107	2.715	143	1.0913
0	161.02	36	30.787	72	7.9913	108	2.6404	144	1.0667
1	153	37	29.544	73	7.7257	109	2.5682	145	1.0429
2	145.42	38	28.359	74	7.4702	110	2.4983	146	1.0197
3	138.26	39	27.227	75	7.2245	111	2.4308	147	0.9971
4	131.5	40	26.147	76	6.9882	112	2.3654	148	0.9752
5	126.17	41	25.114	77	6.7608	113	2.3021	149	0.9538

Note: The information above is for reference only.

2. Removal Procedure

2.1 Removal Procedure of Indoor Unit

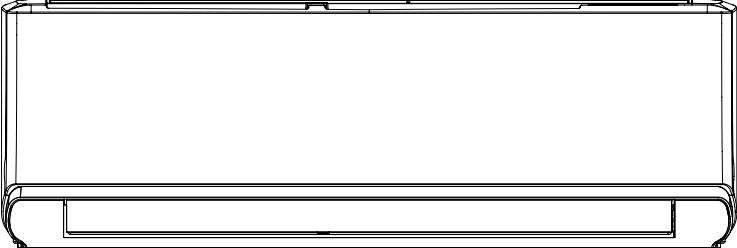
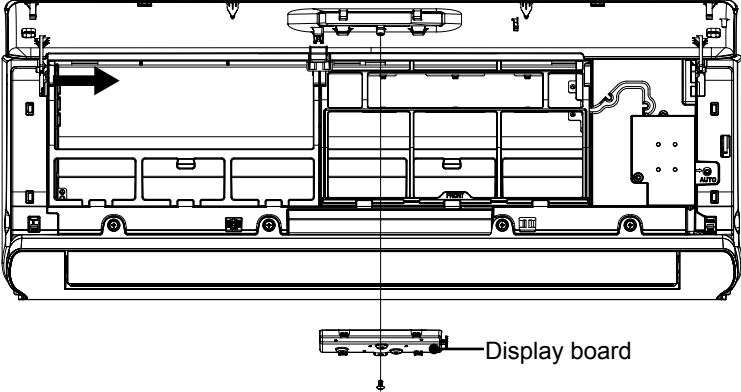
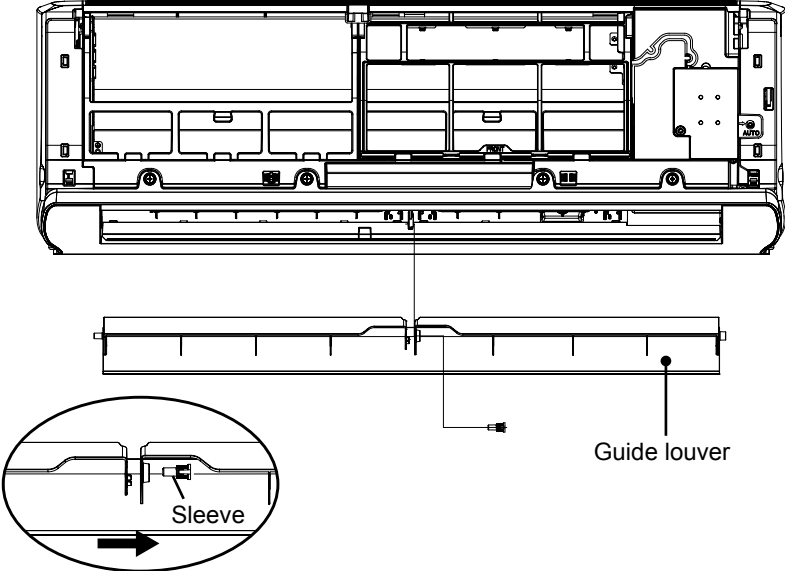

Warning Be sure to wait for a minimum of 10 minutes after turning off all power supplies before disassembly.

Procedure	Note
	<p>1. Before disassembly</p>
 <p style="text-align: center;">Display board</p>	<p>2. Remove panel and Display Board</p> <p>A: Open the front panel.</p> <p>B: Loosen the screws of the display board with screw driver.</p> <p>C: Push the rotor shaft on both sides of the panel to make it separate from the groove. Remove the panel.</p>
 <p style="text-align: center;">Guide louver</p> <p style="text-align: center;">Sleeve</p>	<p>3. Remove guide louver</p> <p>Remove axial sleeve of guide louver.</p>

Procedure

Note

Electric box cover

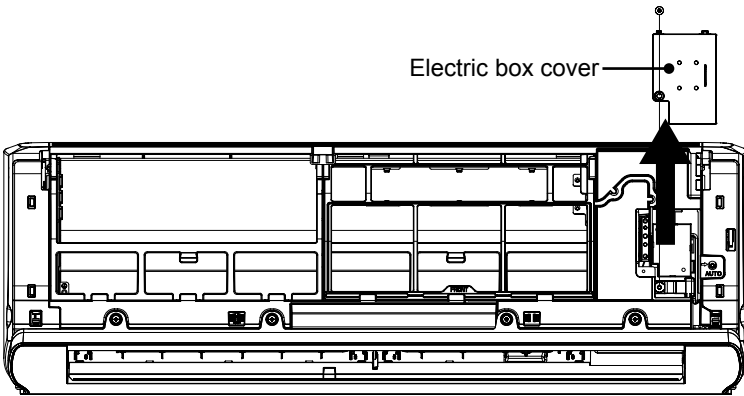

4. Remove electric box cover

Loosen the screws of the electric box cover with screw driver.



5. Remove the filter

Push the filter inward and then draw it upward to remove it.

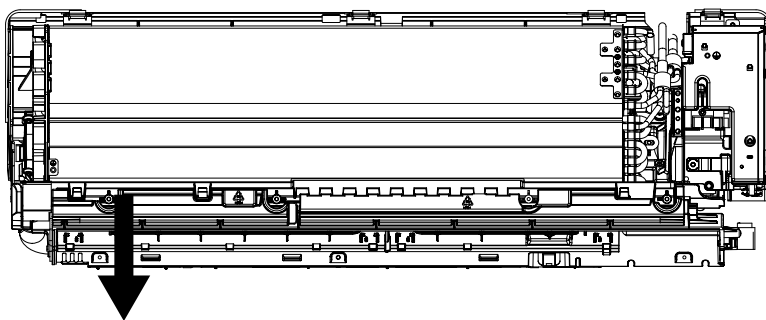
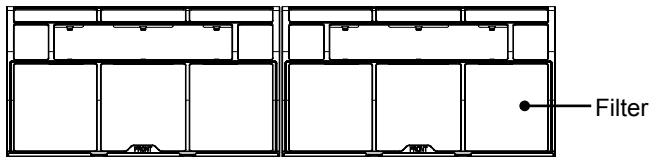

6. Remove the front case

A: Open the screw cap on the front case.
Remove the screws fixing the front case.

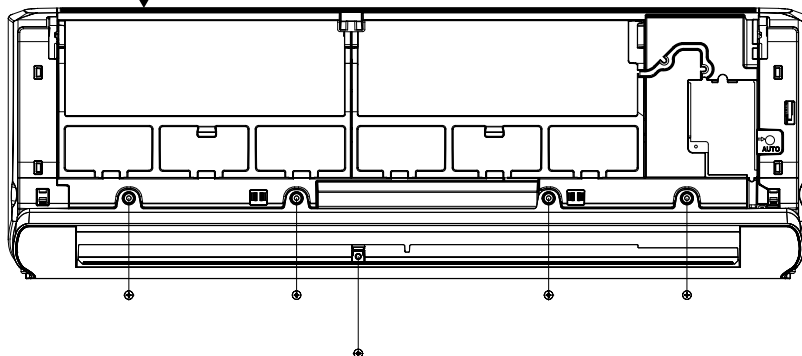

B: Remove the front case to separate it with bottom assembly.

Procedure

Note

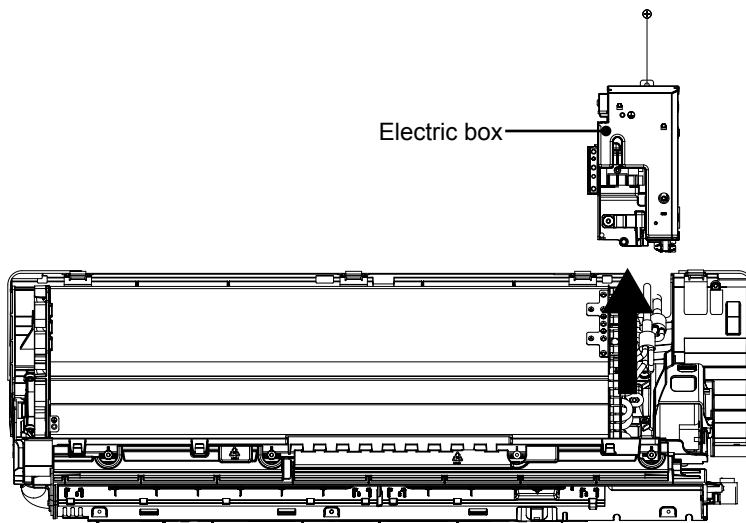
**7. Remove electric box**

- A: Disconnect the indoor tube temperature sensor.
- B: Remove the screws at the joint of the earthing wire and evaporator.
- C: Loosen the clasp at the joint of the electric box.

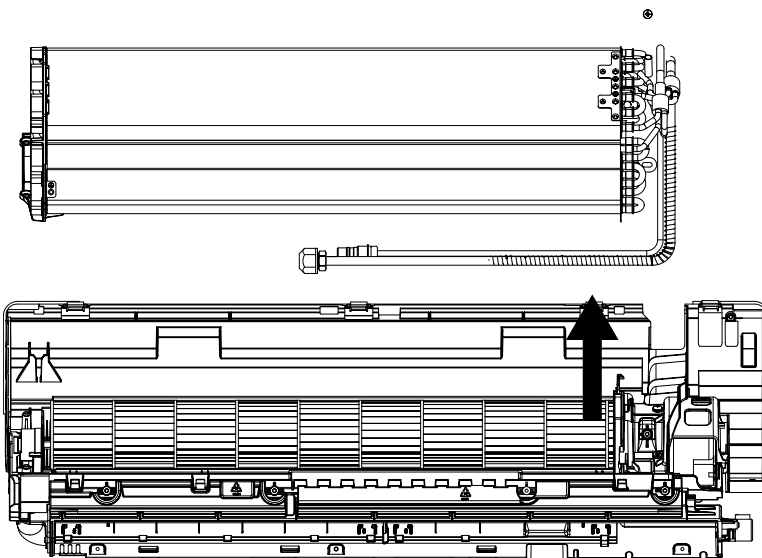
**8. Remove evaporator**

- A: Remove the screws at the joint of the evaporator and rear case.
- B: Adjust slightly the pipe on the evaporator to separate the pipe with the evaporator.
- C: Remove the evaporator to separate the evaporator with rear case assy.

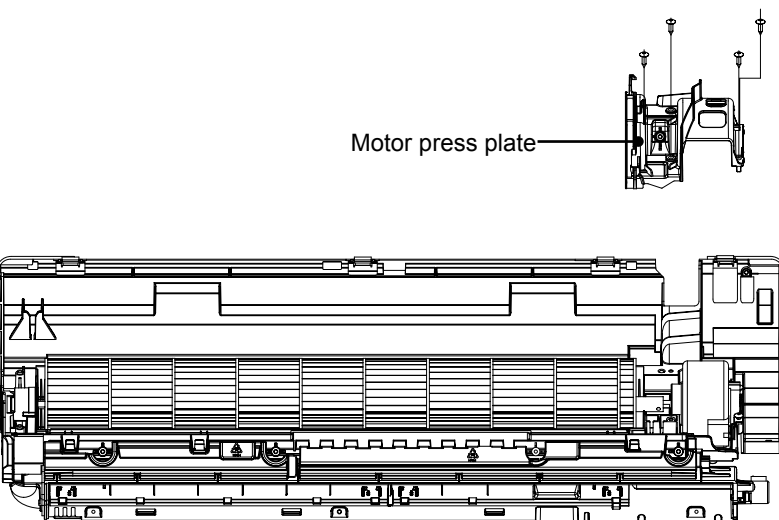
**9. Remove motor press plate**

- Remove the screw of the motor press plate and then remove the press plate.

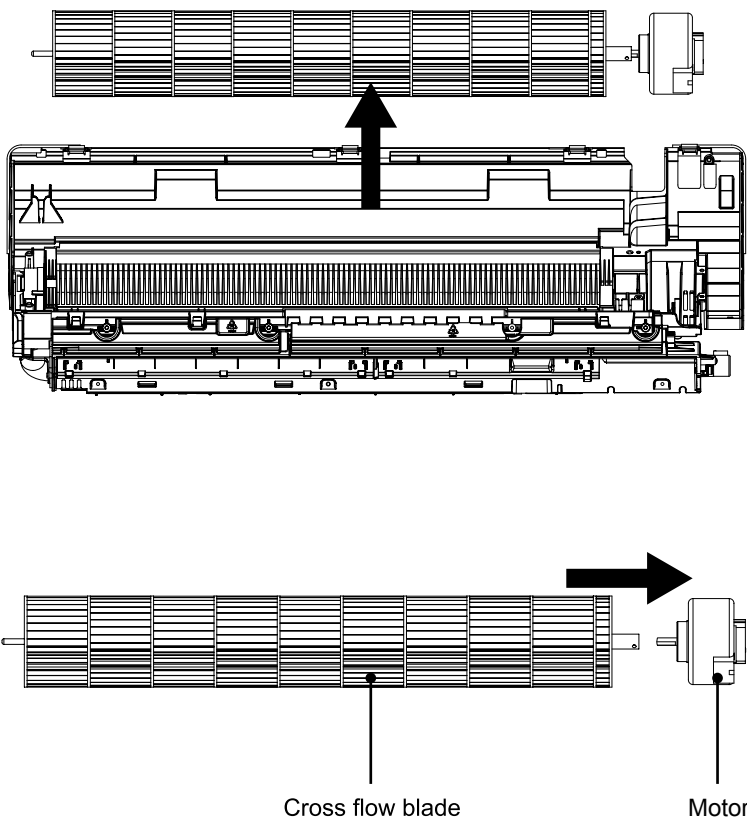
Procedure	Note
 <p>The diagram illustrates the removal of the motor and cross flow blade. The top portion shows a perspective view of the cross flow blade and motor assembly being lifted out of the unit's housing, indicated by a large upward-pointing arrow. The bottom portion shows the assembly with an arrow pointing to the motor, and labels 'Cross flow blade' and 'Motor'.</p>	<p>10. Remove motor and cross flow blade</p> <p>A: Remove the cross flow blade and motor.</p> <p>B: Remove the screws at the joint of the cross flow blade and the motor. Take down the motor.</p>

2.2 Removal Procedure of Outdoor Unit



Warning

Be sure to wait for a minimum of 10 minutes after turning off all power supplies before disassembly.

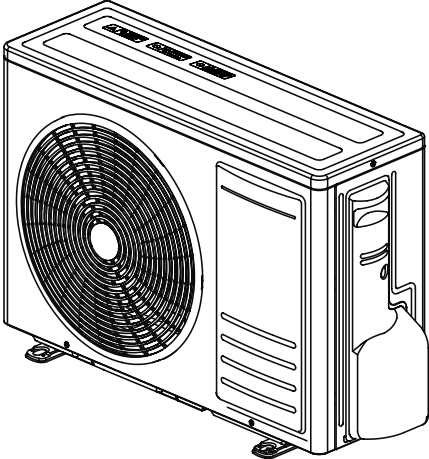
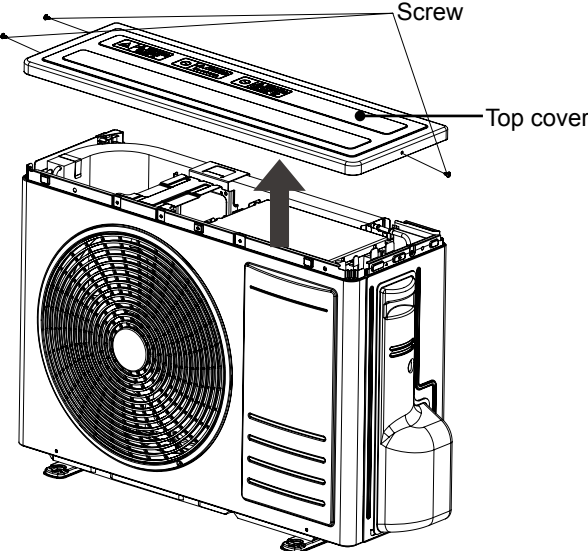
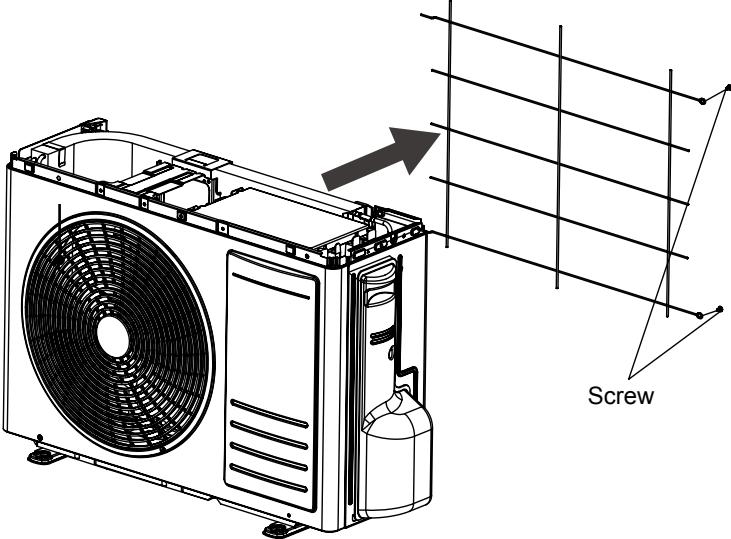
Procedure	Note
	<p>1. Before disassembly</p>
	<p>2. Remove top cover</p> <p>Remove connection screws connecting the top cover plate with the front panel and the right side plate, and then remove the top panel.</p>
	<p>3. Remove protective grille</p> <p>Remove the screws fixing protective grille and then remove the protective grille.</p>

Procedure

Note

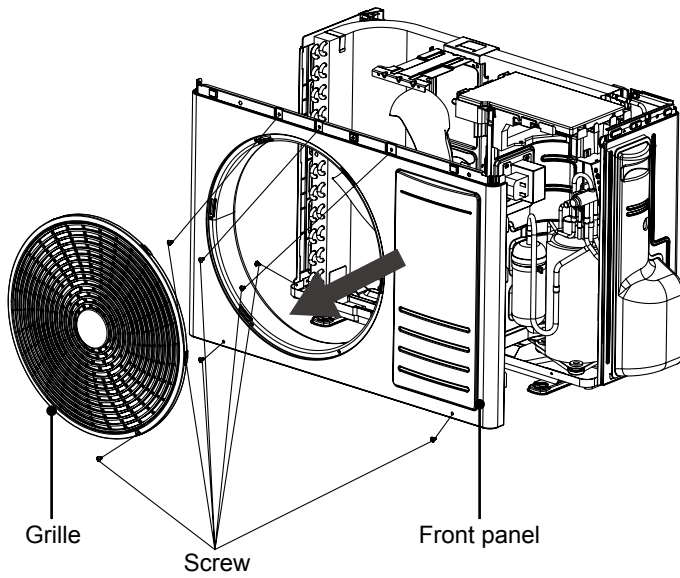

4.Remove grille and panel

A: Remove connection screws between the front grille and the front panel. Then remove the front grille.

B: Remove connection screws connecting the front panel with the chassis and the motor support, and then remove the front panel.

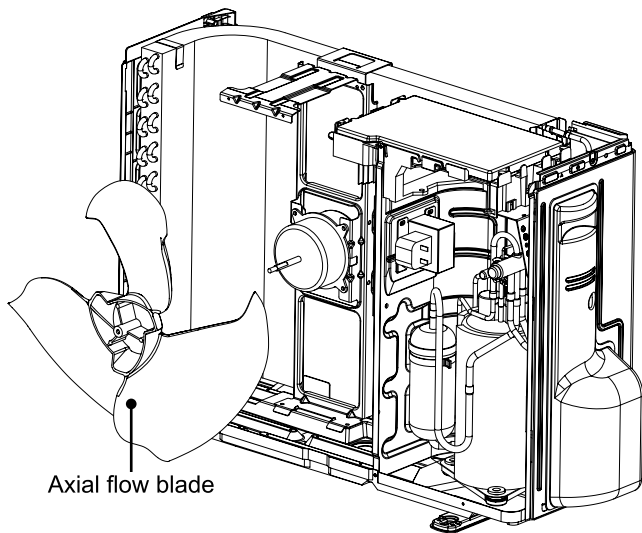

4.Remove axial flow blade

Remove the nut fixing the blade and then remove the axial flow blade.

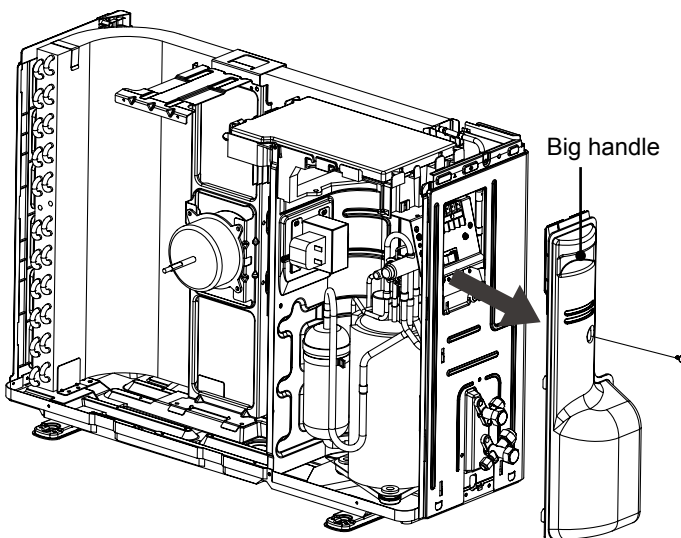

5.Remove big handle

Remove the connection screw fixing the big handle and then remove the handle.

Procedure

Note

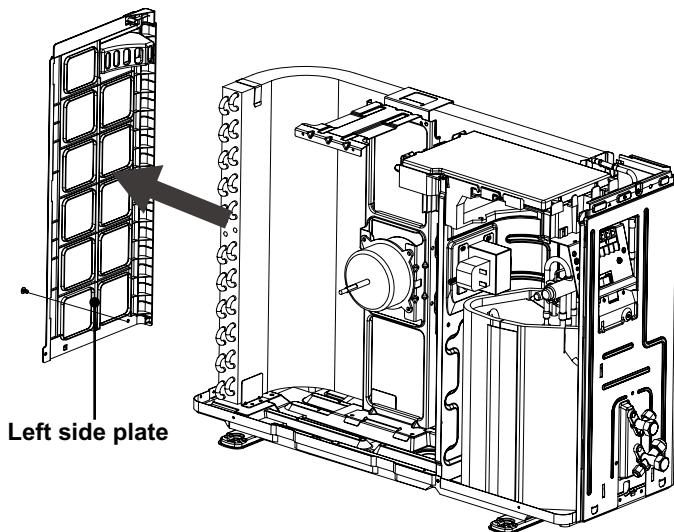
**6. Remove left side plate**

Remove connection screws connecting the left side plate with the condenser assy. Then remove the left side plate.

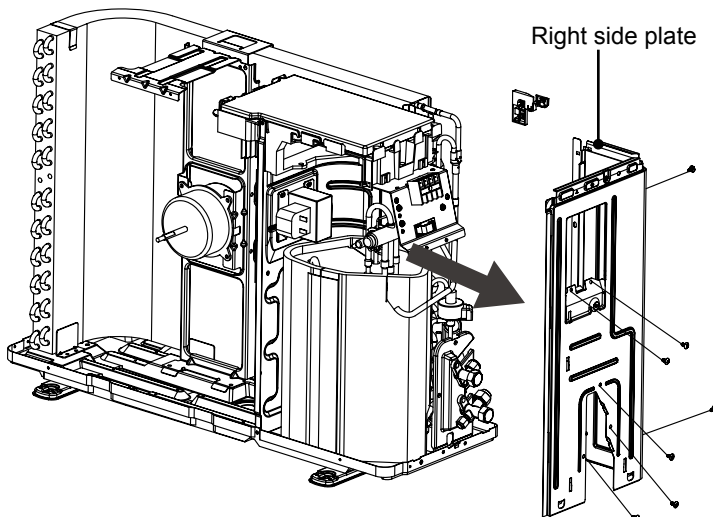
**7. Remove right side plate**

Remove connection screws connecting the right side plate with the valve support and the electric box. Then remove the right side plate.

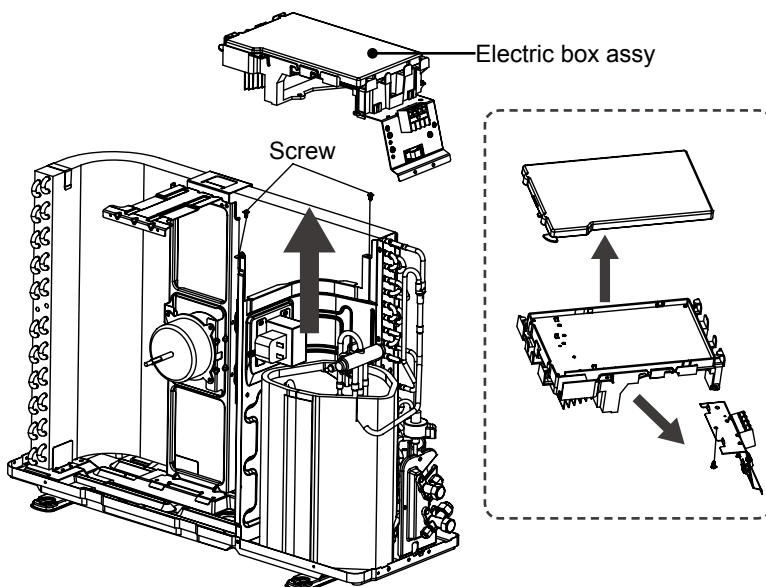
**8. Remove electric box assy**

Remove screws fixing the electric box assy; loosen the wire bundle and unplug the wiring terminals. Then lift the electric box to remove it.

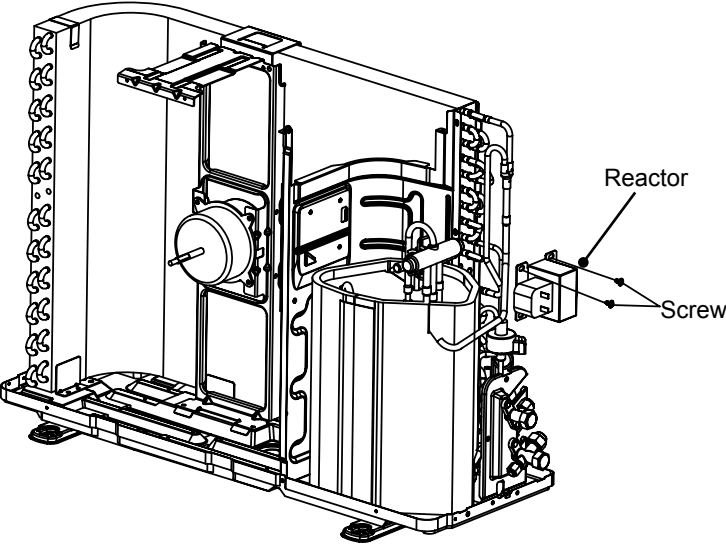
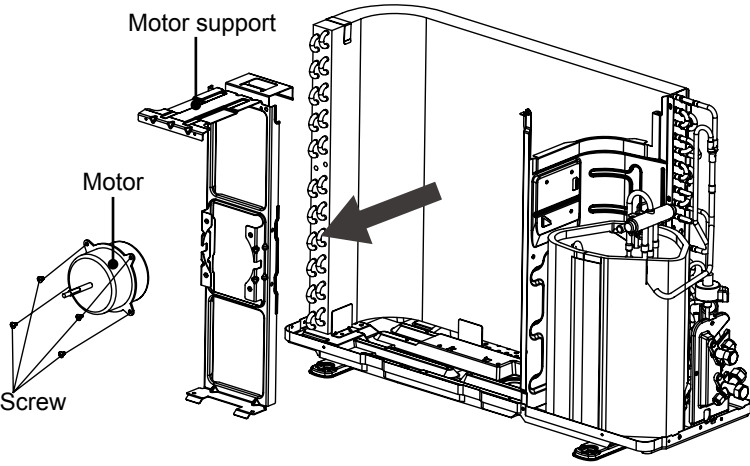
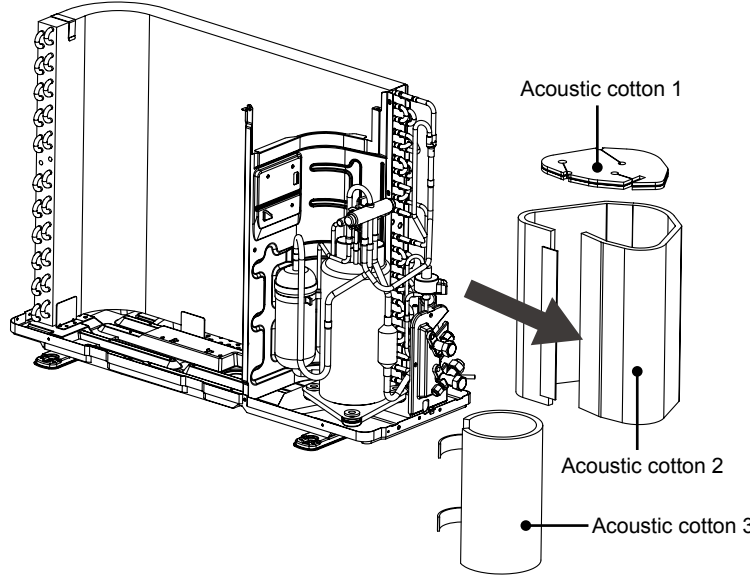
Procedure	Note
	<p>9. Remove Reactor</p> <p>Take off the fixed screw, and you could take off the reactor.</p>
	<p>10. Remove motor and motor support</p> <p>Remove tapping screws fixing the motor and disconnect the leading wire insert of the motor. Then remove the motor. Remove tapping screws fixing the motor and lift the motor support to remove it.</p>
	<p>11. Remove acoustic cotton</p> <p>Split the acoustic cotton lock, and take out 3 pcs slowly. NOTE: Do not damage the pipe.</p>

Procedure

Note

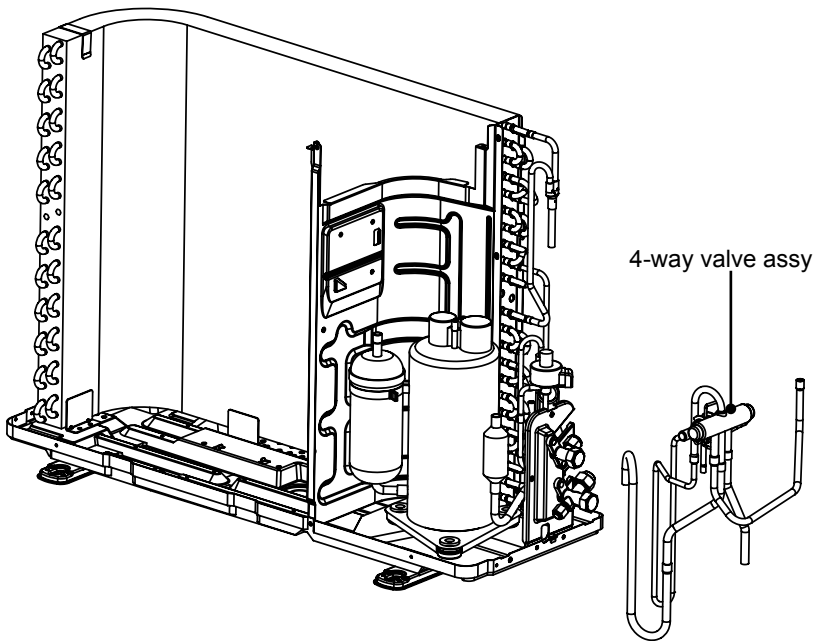
**12. Remove 4-way valve assy**

Unsolder the spot weld of 4-way valve assy, compressor and condenser, and then remove the 4-way valve assy.

**Warning**

Discharge the refrigerant completely before unsoldering, when unsoldering, wrap the gas valve with a wet cloth completely to avoid damage to the valve caused by high temperature.

When unsoldering the spot weld, wrap the 4-way valve with wet cloth completely to avoid damaging the valve due to high temperature.

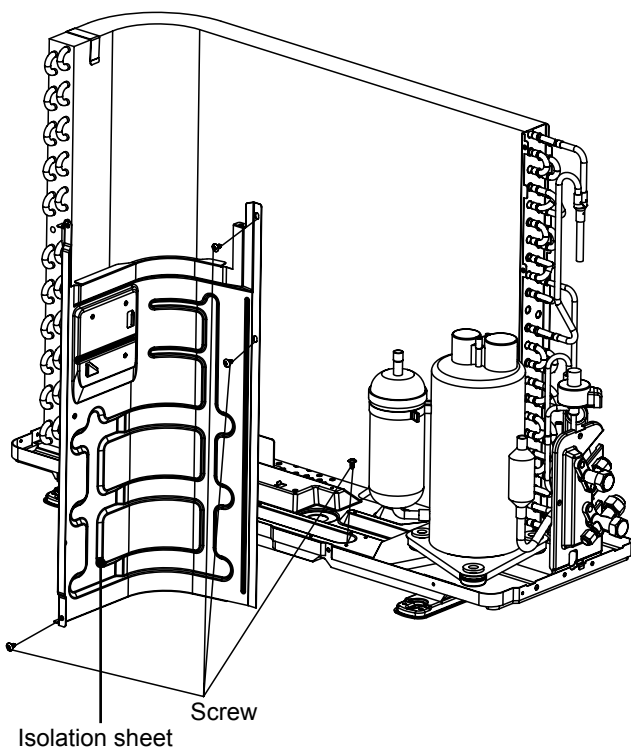
**13. Remove isolation sheet**

Remove the screws fixing the isolation sheet and then remove the isolation sheet.

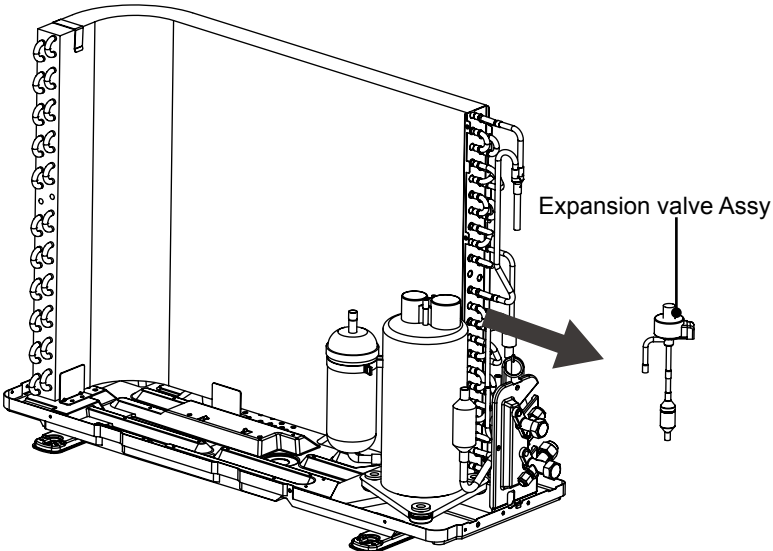
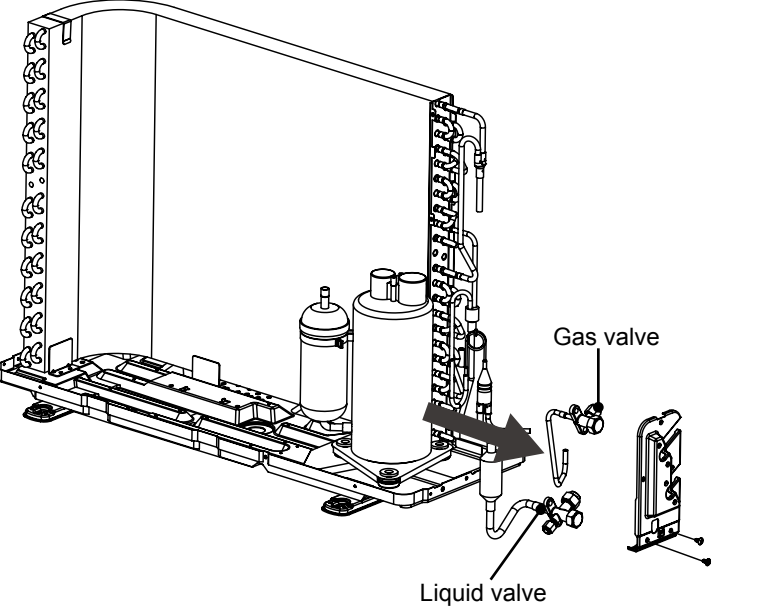
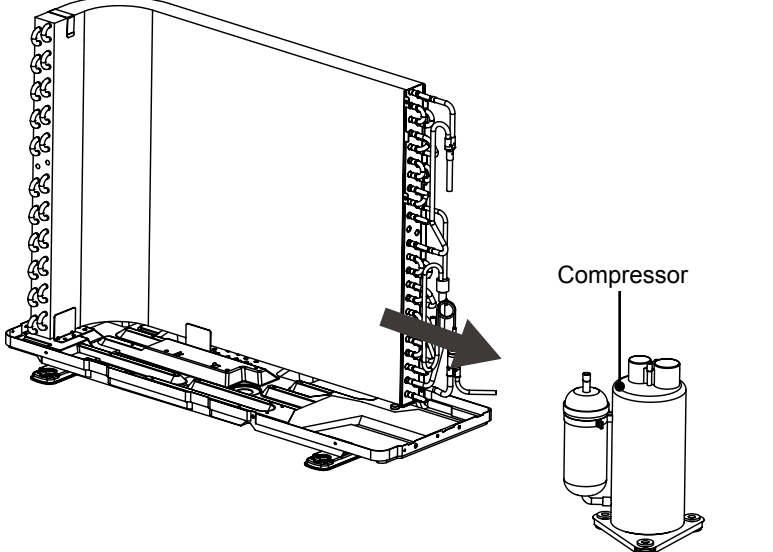
Procedure	Note
 <p>Expansion valve Assy</p>	<p>14. Remove Expansion valve Assy</p> <p>Unsolder the spot weld of expansion valve assy, liquid valve and condenser, and then remove the expansion valve assy .</p>
 <p>Gas valve</p> <p>Liquid valve</p>	<p>14. Remove the compressor</p> <p>A: Remove the 2 screws fixing the gas valve and unsolder the welding joint between the gas valve and the air-return pipe to remove the gas valve.</p>
 <p>Compressor</p>	<p>B: Remove the foot nuts on the compressor and then remove the compressor.</p>



OMEGA
ENVIRONMENTAL
TECHNOLOGIES LLC.

17702 Mitchell North, #101
Irvine, CA. 92614 .USA
Tel: 714 795 2830
Fax: 714 966 1646
info@otecomega.com
www.otecomega.com

OTECTM
AIR CONDITIONING

Showroom & Technology Center
11380 Interchange Circle North
Miramar, FL 33025 .USA
Tel: 305 901 1270
Fax: 954 212 8280
info@otecvrf.com
www.otecvrf.com

IEVW(CHV)I2A-SM1Y0622