

SCVC Series

14 SEER Units

Service Manual

208~230V/1/60Hz



Content

- Part 1. General Information..... 1**
 - 1. Model Names of Indoor/Outdoor Units4
 - 2. External Appearance5
 - 3. Features.....6

- Part 2. Indoor Unit..... 7**
 - 1. Features8
 - 2. Dimension10
 - 3. Service Space.....11
 - 4. Wiring Diagrams.....12
 - 5. The Specification of Wiring.....14
 - 6. Field Wiring.....15

- Part 3 Outdoor Unit..... 16**
 - 1. Dimension.....17
 - 2. Service Space.....18
 - 3. Wiring Diagrams19
 - 4. Operation Limits20
 - 5. Refrigerate diagram.....21

- Part 4 Unit maintenance 22**
 - 1. Fault indicator of indoor unit.....23
 - 2. Fault indicator of outdoor unit24
 - 3.Flow chart of troubleshooting25

Part 1. General Information

1. Model Names of Indoor/Outdoor Units	2
2. External Appearance	3
3. Features	4

1. Model Names of Indoor/Outdoor Units

1.1 Indoor Units

Model name	Dimension(W×H×D)(inch)	Power supply
SEER 14 Cooling Only & Heat Pump		
SEUA418S2A-GNE053A	19-2/3×45-3/4×22	208~230V-1Ph-60Hz
SEUA424S2A-GNE070A	19-2/3×45-3/4×22	208~230V-1Ph-60Hz
SEUA430S2A-GNE090A	19-2/3×45-3/4×22	208~230V-1Ph-60Hz
SEUA436S2A-GNE105A	19-2/3×45-3/4×22	208~230V-1Ph-60Hz
SEUA442S2A-GNE125A	19-2/3×45-3/4×22	208~230V-1Ph-60Hz
SEUA448S2A-GNE140A	22×53-1/8×24-1/2	208~230V-1Ph-60Hz
SEUA460S2A-GNE160A	22×53-1/8×24-1/2	208~230V-1Ph-60Hz

1.2 Outdoor Units

Model name	Dimension (W×H×D) (inch)	Power supply
SEER 14 Cooling Only		
SCVC418S2A-GHE053A	21-5/6×25×21-5/6	208~230V-1Ph-60Hz
SCVC424S2A-GHE070A	21-5/6×25×21-5/6	208~230V-1Ph-60Hz
SCVC430S2A-GHE090A	21-5/6×25×21-5/6	208~230V-1Ph-60Hz
SCVC436S2A-GHE105A	29-1/8×25×29-1/8	208~230V-1Ph-60Hz
SCVC442S2A-GHE125A	29-1/8×32-5/6×29-1/8	208~230V-1Ph-60Hz
SCVC448S2A-GHE140A	29-1/8×32-5/6×29-1/8	208~230V-1Ph-60Hz
SCVC460S2A-GHE160A	29-1/8×32-5/6×29-1/8	208~230V-1Ph-60Hz

Model name	Dimension (W×H×D) (inch)	Power supply
SEER 14 Cooling & Heat Pump		
SCVC418H2A-GHE053A	21-5/6×25×21-5/6	208~230V-1Ph-60Hz
SCVC424H2A-GHE070A	21-5/6×25×21-5/6	208~230V-1Ph-60Hz
SCVC430H2A-GHE090A	21-5/6×25×21-5/6	208~230V-1Ph-60Hz
SCVC436H2A-GHE105A	29-1/8×25×29-1/8	208~230V-1Ph-60Hz
SCVC442H2A-GHE125A	29-1/8×32-5/6×29-1/8	208~230V-1Ph-60Hz
SCVC448H2A-GHE140A	29-1/8×32-5/6×29-1/8	208~230V-1Ph-60Hz
SCVC460H2A-GHE160A	29-1/8×32-5/6×29-1/8	208~230V-1Ph-60Hz

2. External Appearance

2.1 Indoor unit



2.2 Outdoor unit



Note: Standard outdoor unit is using plastic grill. Metal grill can be customized.

3. Features

3.1 Operation features

- Long Piping & Cost Effective
- Low noise operation, as low as 57dB(A)
- 24V control, time delay relay, fan relay and transformer included.

3.2 Performance features

- AHRI Certified & ETL listed.
- R410A environment friendly refrigerant.
- Wide operation temperature range: Cooling: 64⁰F-109⁰F; Heating: 20⁰F-109⁰F
- Continuous Cooling Transformation Inner-grooved tube has high thermometric conductivity.

3.3 Reliability features

- Painted galvanized steel cabinet.
- Well-known brand fixed compressor, reliable quality.
- Condenser coils constructed with copper tubing and enhanced aluminum fins.
- 3-speed direct drive motors, provide selections of air flow to meet desired applications.
- Intelligent defrost programs, unit will choose different defrost program according to real condition.

Part 2. Indoor Unit

1.Features	8
2.Dimension	10
3.Service Space	11
4.Wiring Diagrams	12
5.The Specification of Wiring	14
6.Field Wiring	15

1. Features

(1) "A" shape coils, constructed with copper tubing and enhanced aluminum fins.

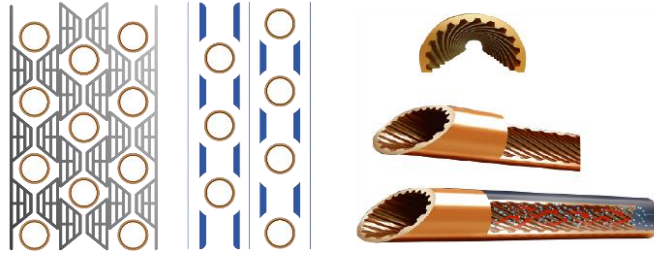

(2) Direct drive motors, 3 speed, provide selections of air flow to meet desired applications.

(3) $\varphi 10''$ large fan blade that has powerful wind speed, and the motor is covered with insulation material, which can ensure that the motor runs in a safe state.

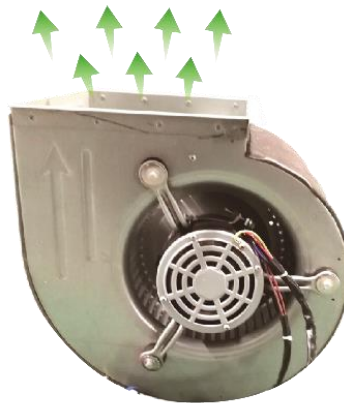

(4) Use TXV as throttle device (14 SEER air handler)

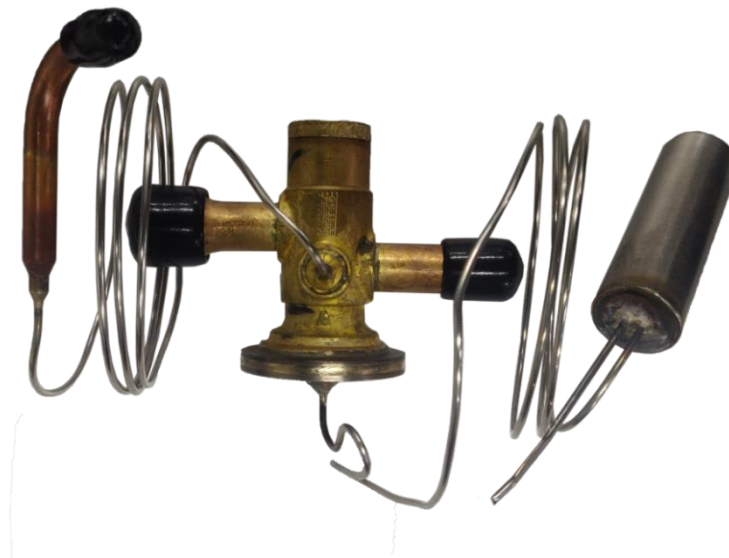

(5) Detachable air filter for cleaning or renewal

Versatile 4-way convertible design for vertical up airflow, horizontal right airflow.

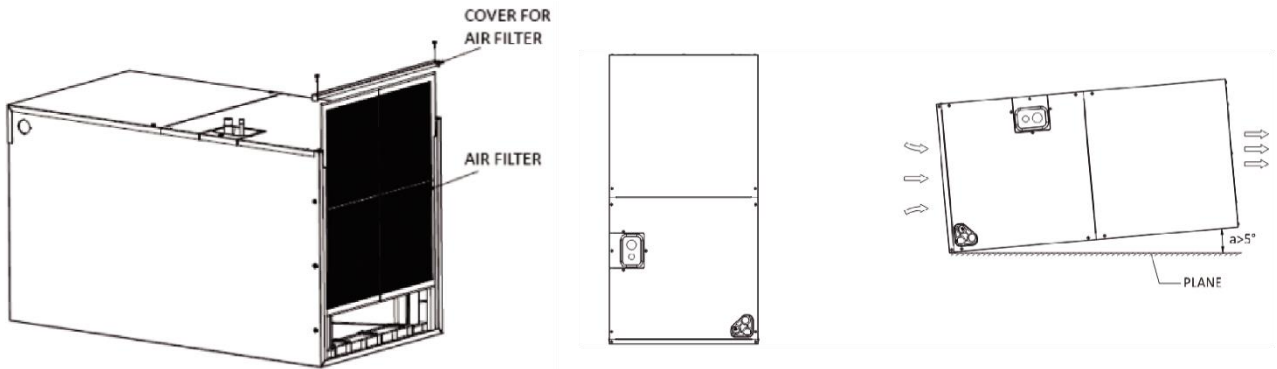

Notes:

1. Nominal cooling capacities are based on the following conditions:
Indoor temp: 27°CDB, 19°CWB; Outdoor temp: 35°CDB; Equivalent ref. piping: 5m (horizontal)
2. Nominal heating capacities are based on the following conditions:
Indoor temp: 20°CDB; Outdoor temp: 7°CDB, 6°CWB; Equivalent ref. piping: 5m (horizontal)
3. Actual noise level may differ, depending on the room structure, etc., since these noise values are from an anechoic room.

2. Dimension

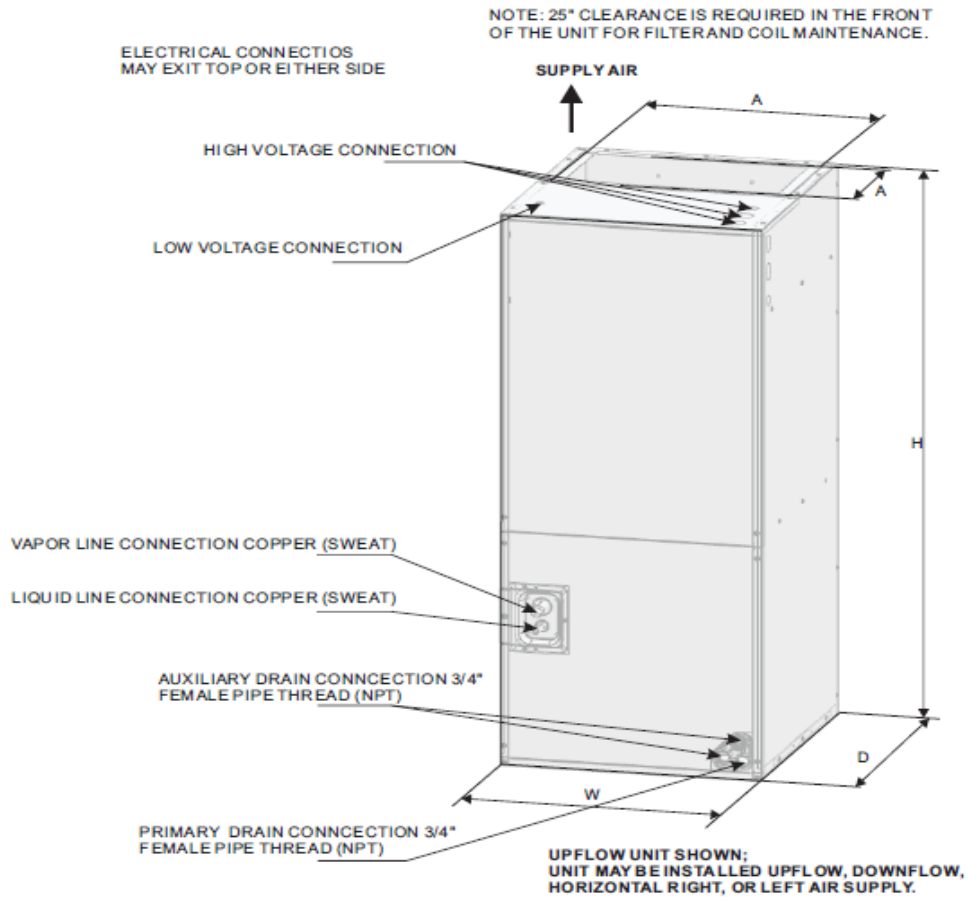

DIMENSIONAL DATA

Fig.1 DIMENSIONS

MODEL SIZE	Dimensions inch [mm]				
	UNIT HEIGHT "H" IN. [mm]	UNIT WIDTH "W" IN. [mm]	UNIT LENGTH "D" IN. [mm]	SUPPLY DUCT "A" IN [mm]	LIQUID LINE/ VAPOR LINE IN
18K	45-3/4" [1162]	19-2/3" [500]	22" [560]	17-7/8" [454]	3/8" / 3/4"
24K	45-3/4" [1162]	19-2/3" [500]	22" [560]	17-7/8" [454]	3/8" / 3/4"
30K	45-3/4" [1162]	19-2/3" [500]	22" [560]	17-7/8" [454]	3/8" 3/4"
36K	45-3/4" [1162]	19-2/3" [500]	22" [560]	17-7/8" [454]	3/8" 3/4"
42K	45-3/4" [1162]	19-2/3" [500]	22" [560]	17-7/8" [454]	3/8" 3/4"
48K	53-1/8" [1350]	22" [560]	24-1/2" [623]	19-1/2" [496]	3/8" 7/8"
60K	53-1/8" [1350]	22" [560]	24-1/2" [623]	19-1/2" [496]	3/8" / 7/8"

3. Service Space

The indoor unit should be installed in a location that meets the following requirements:
INSTALLATION NOTES: .

1. When up hand discharge , how to trap or plug all drains is see the left Figure.
2. When right hand discharge , how to trap or plug all drains is see the top Figure.
3. The seal-plugs are supplied as accessories , and be screwed tightly only with hand.

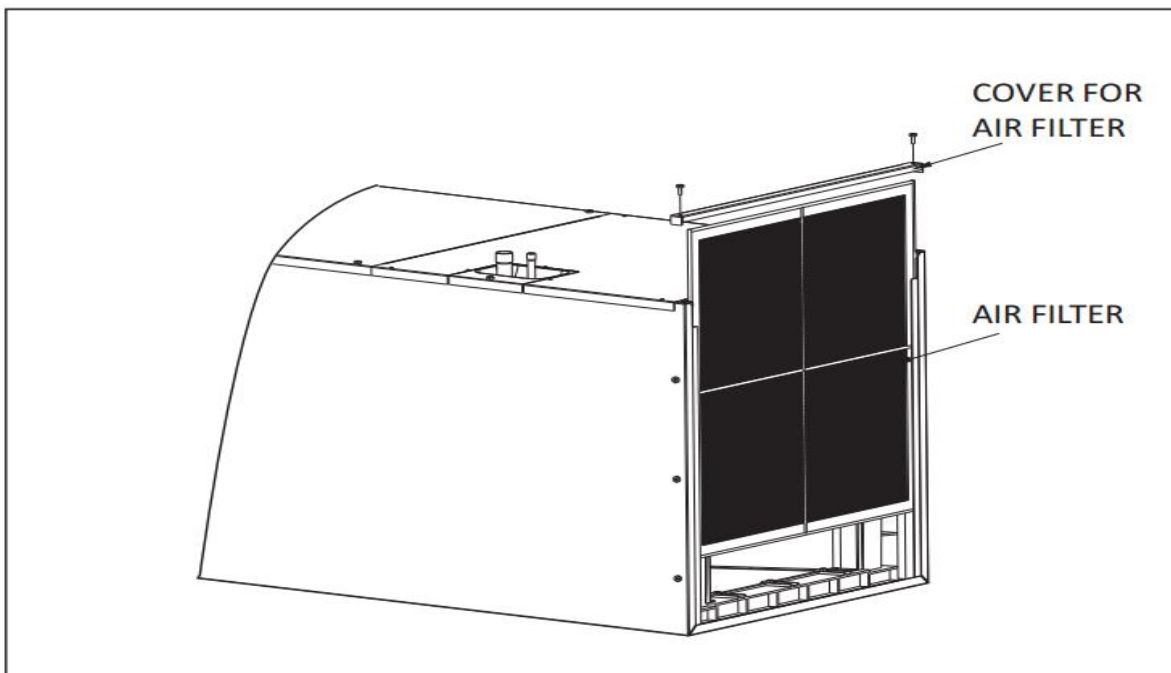
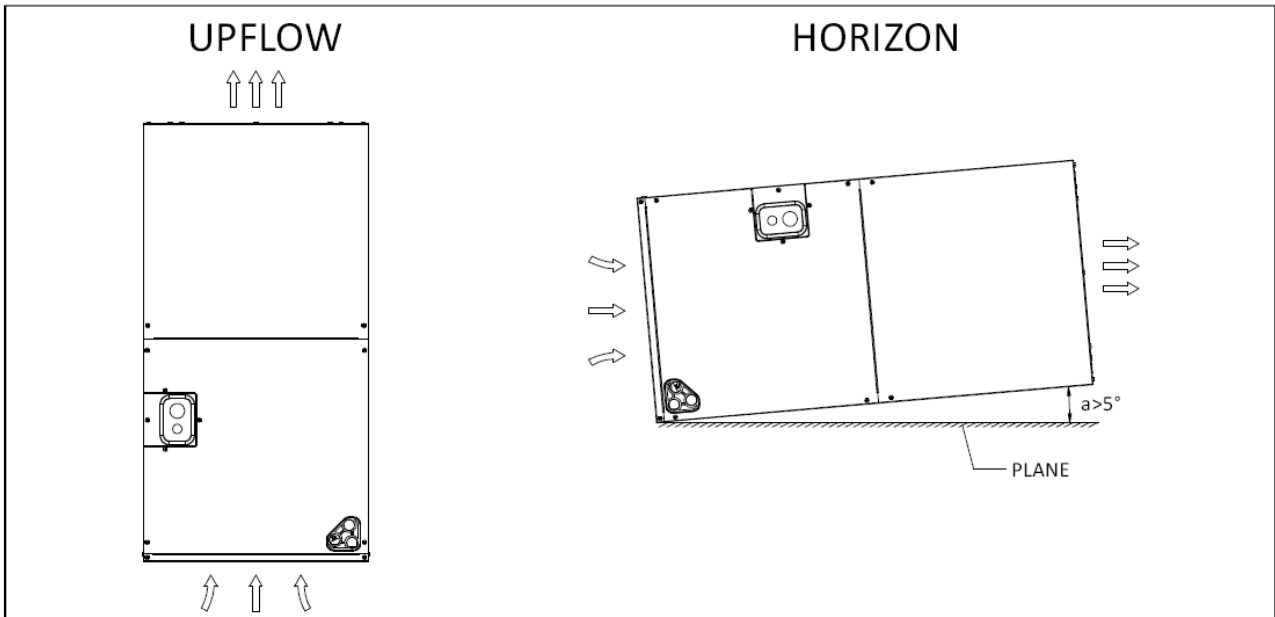

4. Wiring Diagrams

SEUA418(24,30,36,42)S2A-GNE053(70,90,105,125)A

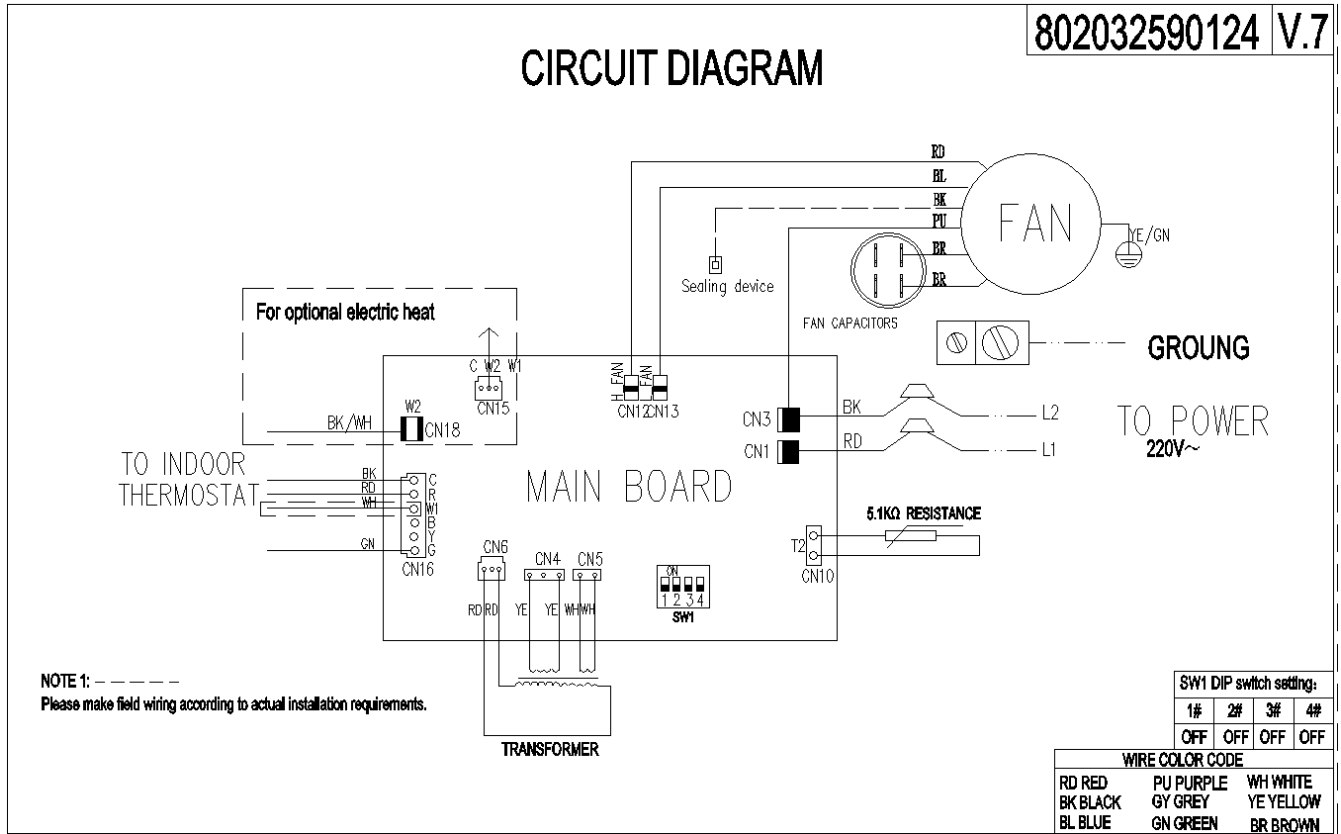

SEUA448S2A-GNE140A

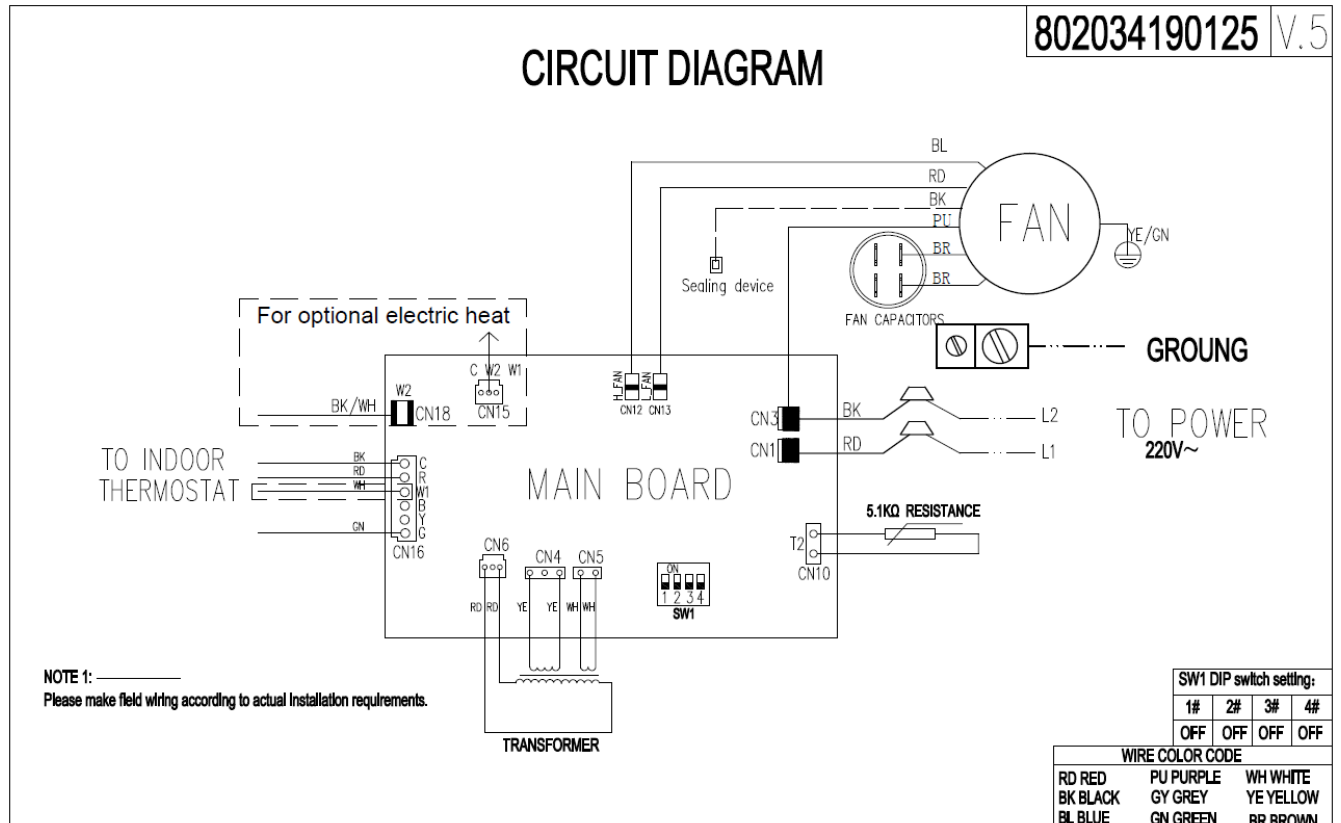

SEUA460S2A-GNE160A

802034590109 V.4

CIRCUIT DIAGRAM

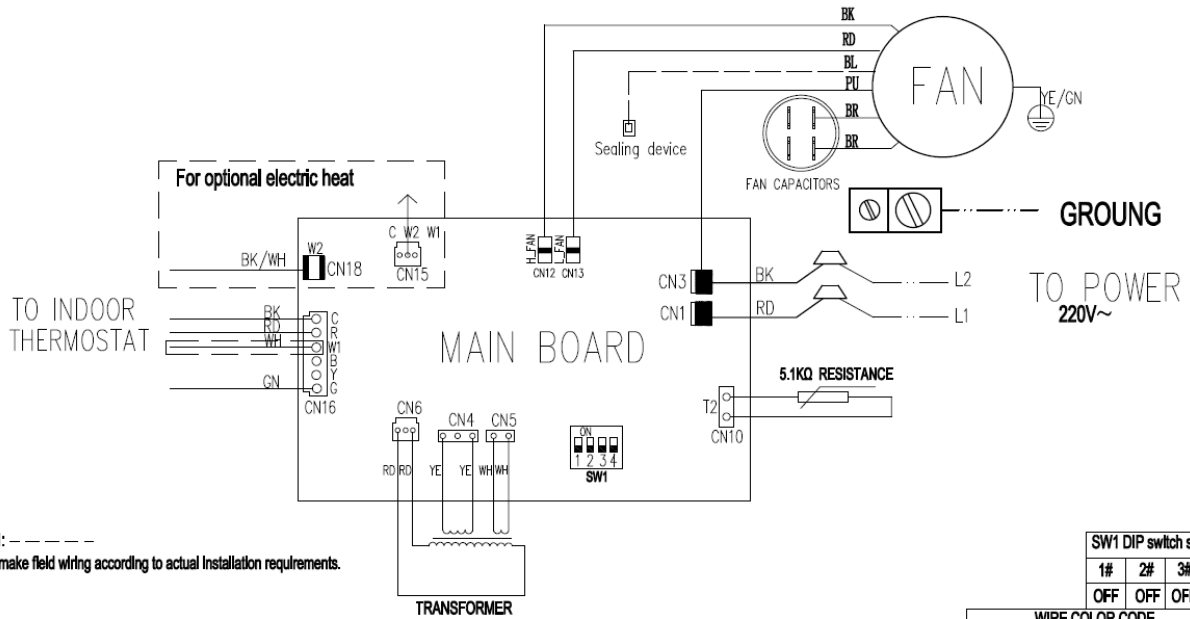

NOTE 1: - - - - -
Please make field wiring according to actual installation requirements.

SW1 DIP switch setting:			
1#	2#	3#	4#
OFF	OFF	OFF	OFF

WIRE COLOR CODE		
RD RED	PU PURPLE	WH WHITE
BK BLACK	GY GREY	YE YELLOW
BL BLUE	GN GREEN	BR BROWN

5. The Specification of Wiring

Note:

The cross-section areas of wires or lines should not be less than the corresponding ones listed in the table below; Besides, if the power wires is quite long from the unit, please choose the windings with larger cross-section area to guarantee the normal power supply.

Model	Type	Indoor power wires	Thermostat communication wires		Outdoor power wires
			Indoor	Outdoor	
SEUA418S2A- GNE053A	Cooling only	3*1.0mm ²	3*0.75mm ²	2*0.75mm ²	3*1.0mm ²
SEUA424S2A- GNE070A	Cooling only		3*0.75mm ²	2*0.75mm ²	3*2.5mm ²
SEUA430S2A- GNE090A	Cooling only		3*0.75mm ²	2*0.75mm ²	
SEUA436S2A- GNE105A	Cooling only		3*0.75mm ²	2*0.75mm ²	
SEUA442S2A- GNE125A	Cooling only		3*0.75mm ²	2*0.75mm ²	3*4mm ²
SEUA448S2A- GNE140A	Cooling only		3*0.75mm ²	2*0.75mm ²	
SEUA460S2A- GNE160A	Cooling only		3*0.75mm ²	2*0.75mm ²	

6. Field Wiring

1. To avoid the electrical shock, please connect the air conditioner with the ground lug. The main power plug in the air conditioner has been joined with the ground wiring, please don't change it freely.
2. The power socket is used as the air conditioner specially.
3. Don't pull the power wiring hard.
4. When connecting the air conditioner with the ground, observe the local codes.
5. If necessary, use the power fuse or the circuit, breaker or the corresponding scale ampere.

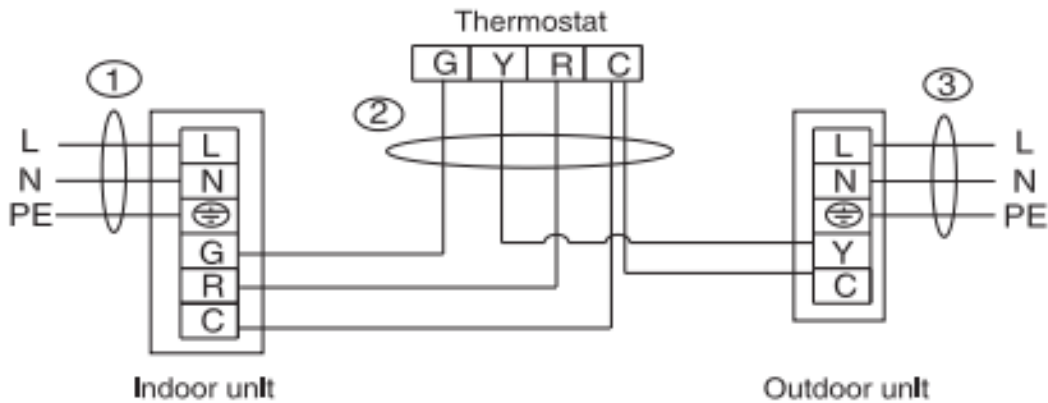

Applicable for 18k, 24k, 30k, 36k, 42k, 48k, 60k cooling only type

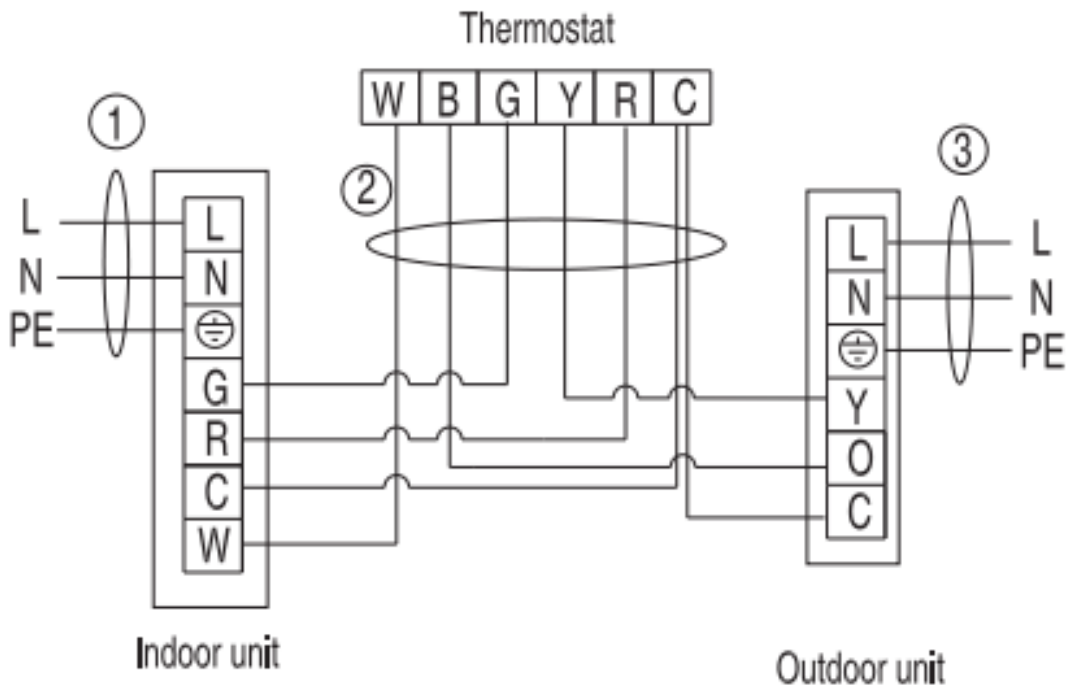

Applicable for 18k, 24k, 30k, 36k, 42k, 48k, 60k cooling & heating type

Part 3 Outdoor Unit

1. Dimensions.....	17
2. Service Space	18
3. Wiring Diagrams	19
4. Operation Limits	20
5. Refrigerate diagram.....	21

1. Dimension

All dimensions are in mm. They are subject to change without notice. Certified dimensions will be provided upon request.

Unit Model	Dimensions(mm)			Refrigerant Connection Line Size(mm)			
	A	B	C	Liquid(Φ)		Vapor(?)	
				LF	RF	LF	RF
18	633	554	554	9.52		19.05	
24(30)	633	554	554				
30	633	554	554				
36	633	740	740				
42	835	740	740				
48	835	740	740				
60	835	740	740			22	

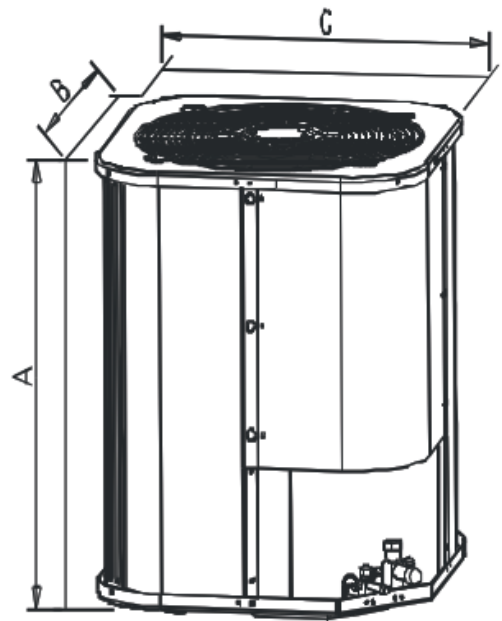

NOTE: LF means cooling only model; RF means heat pump model.

2. Service Space

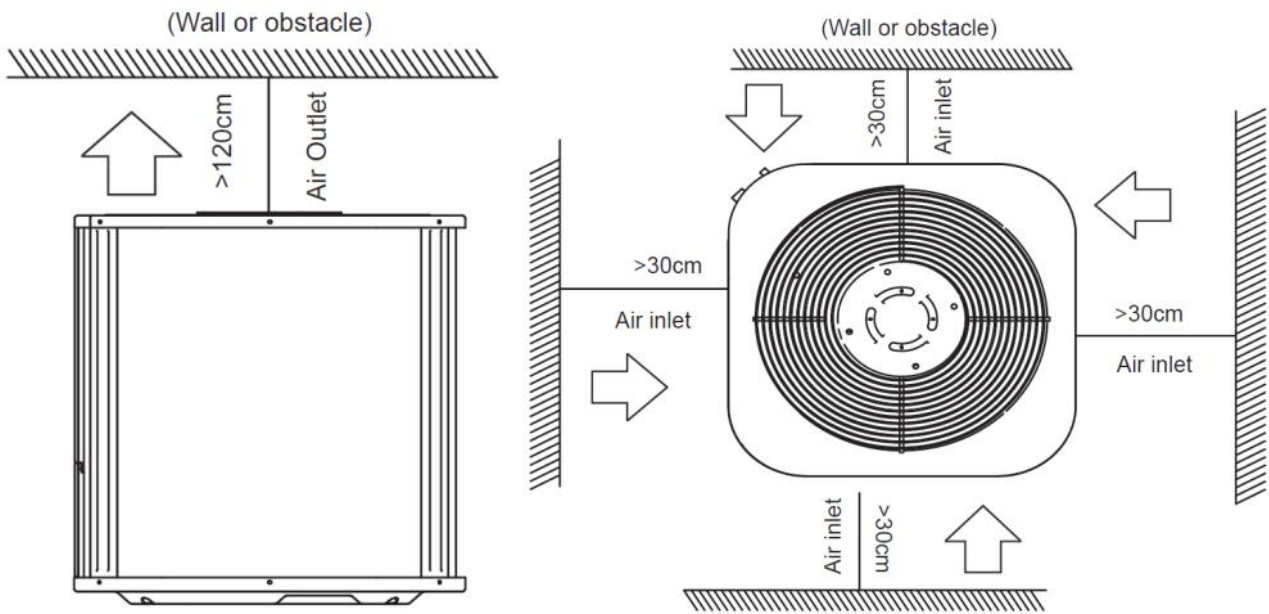

TYPICAL INSTALLATION

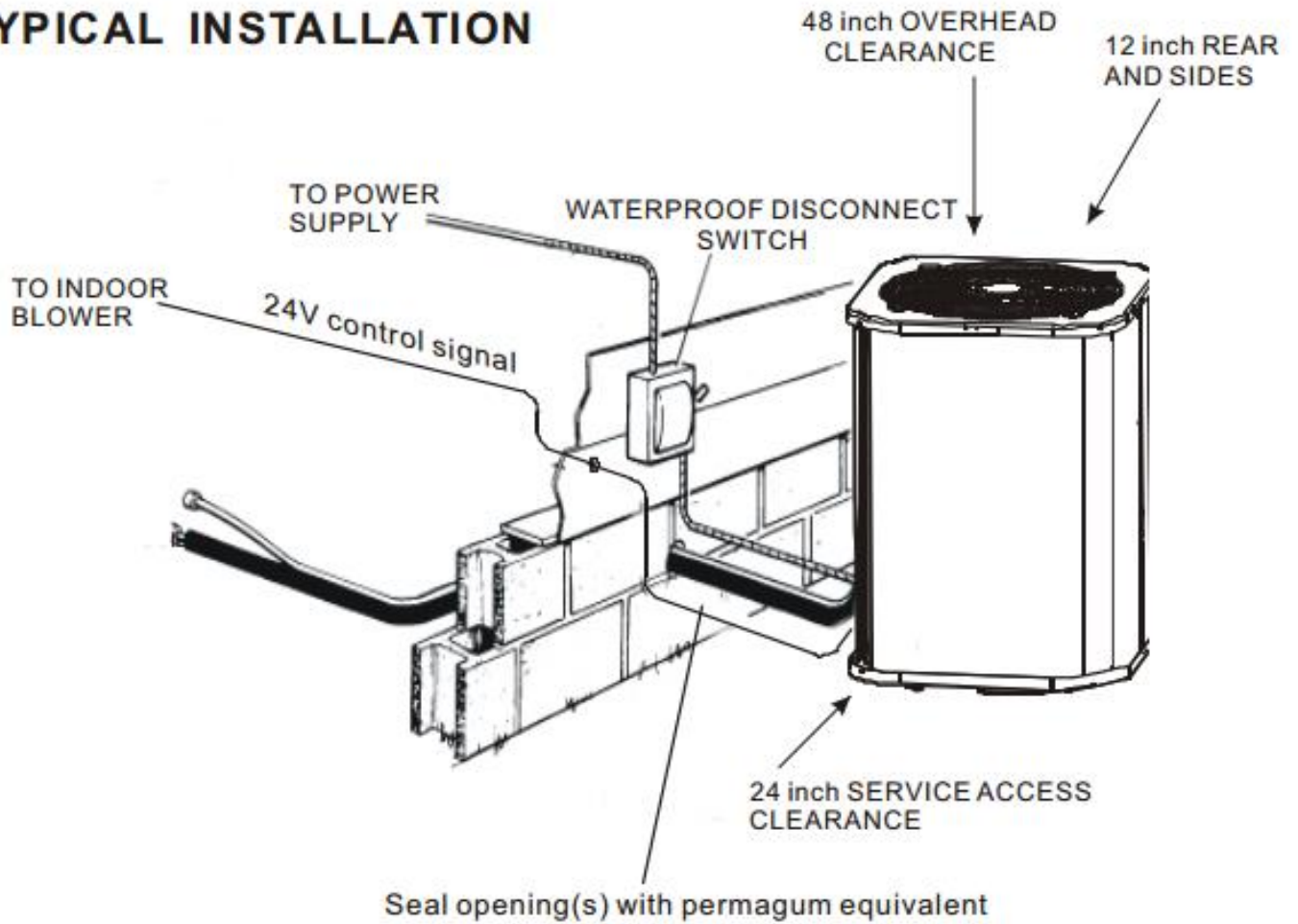

3. Wiring Diagrams

SEER 14 Cooling only

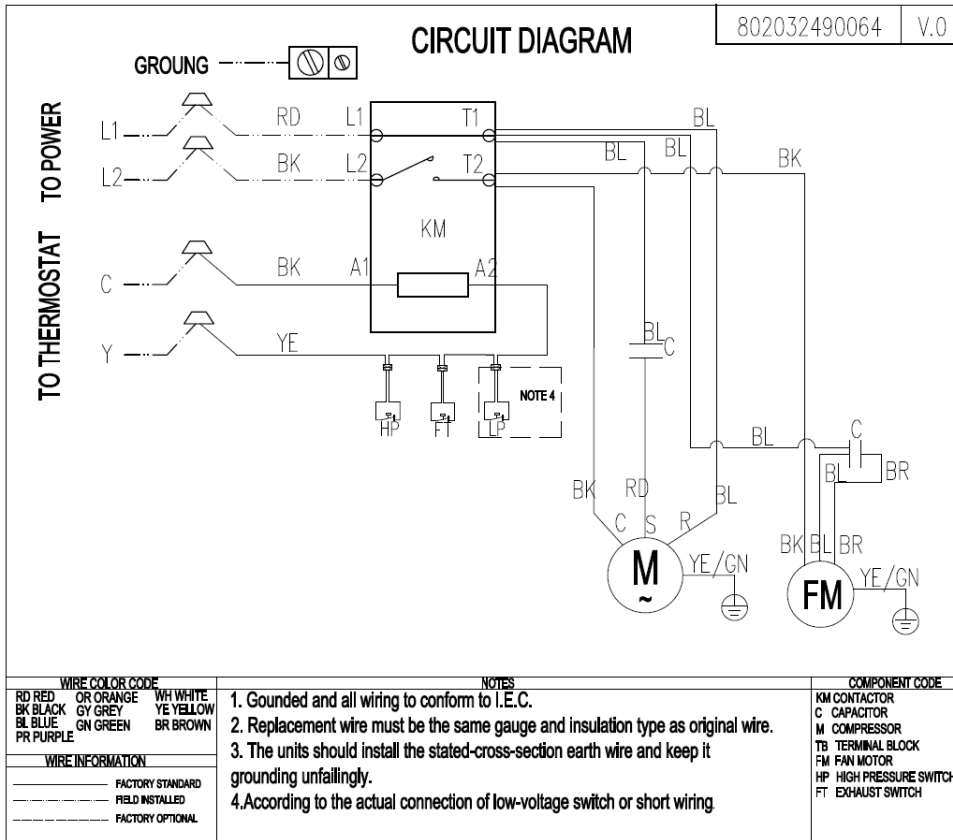

4. Operation Limits

Operation mode	Outdoor temperature(°C)	Room temperature(°C)
Cooling operation	18~43	17~30

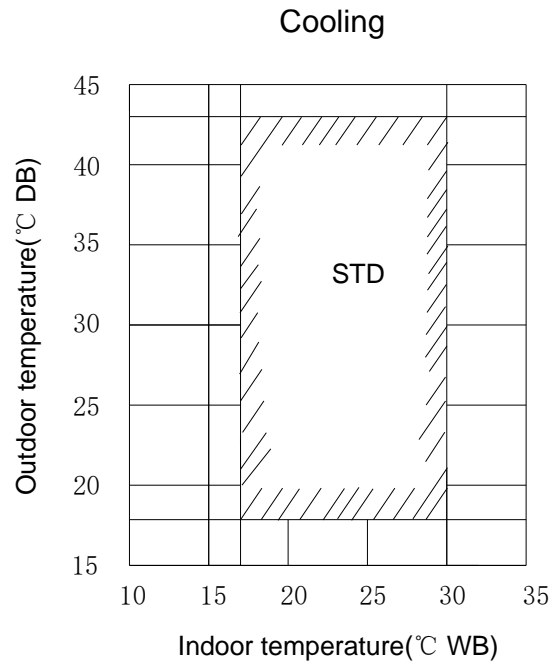

5. Refrigerate diagram

Applicable for 18K,24K,30K,36K cooling only type

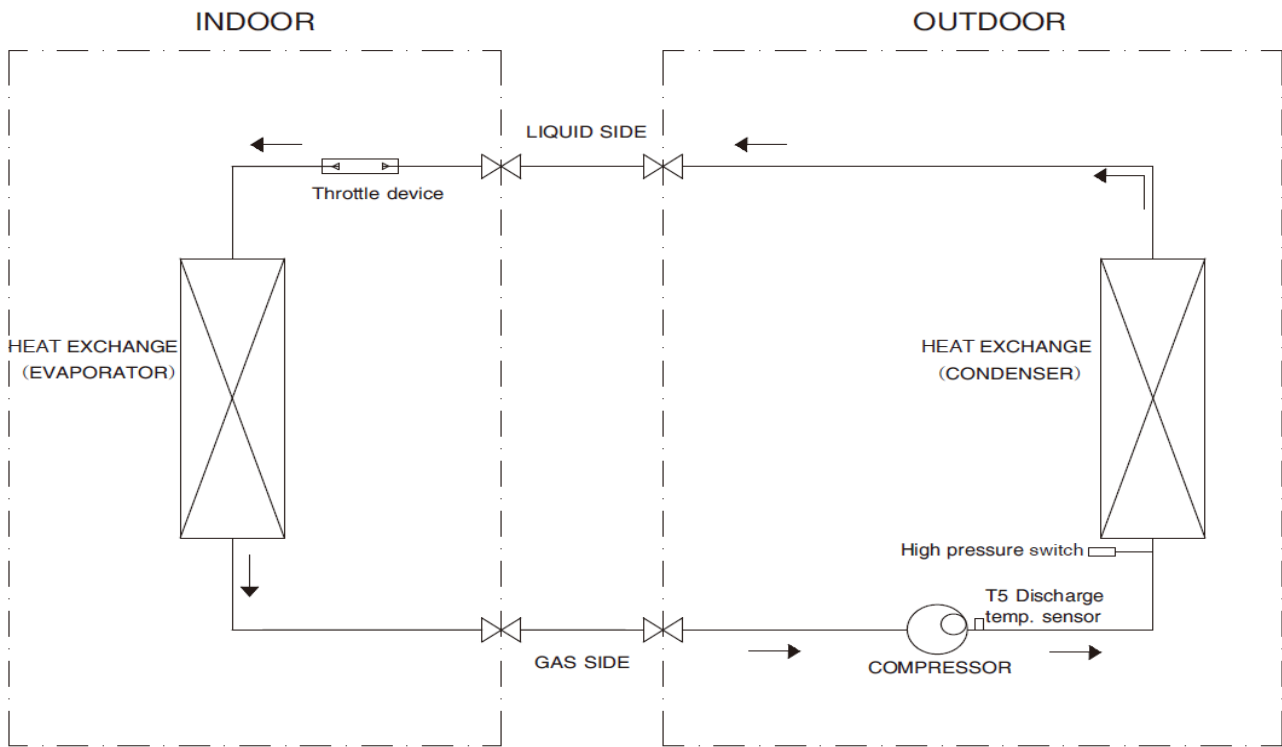

Applicable for 42K,48K, 60K cooling only type

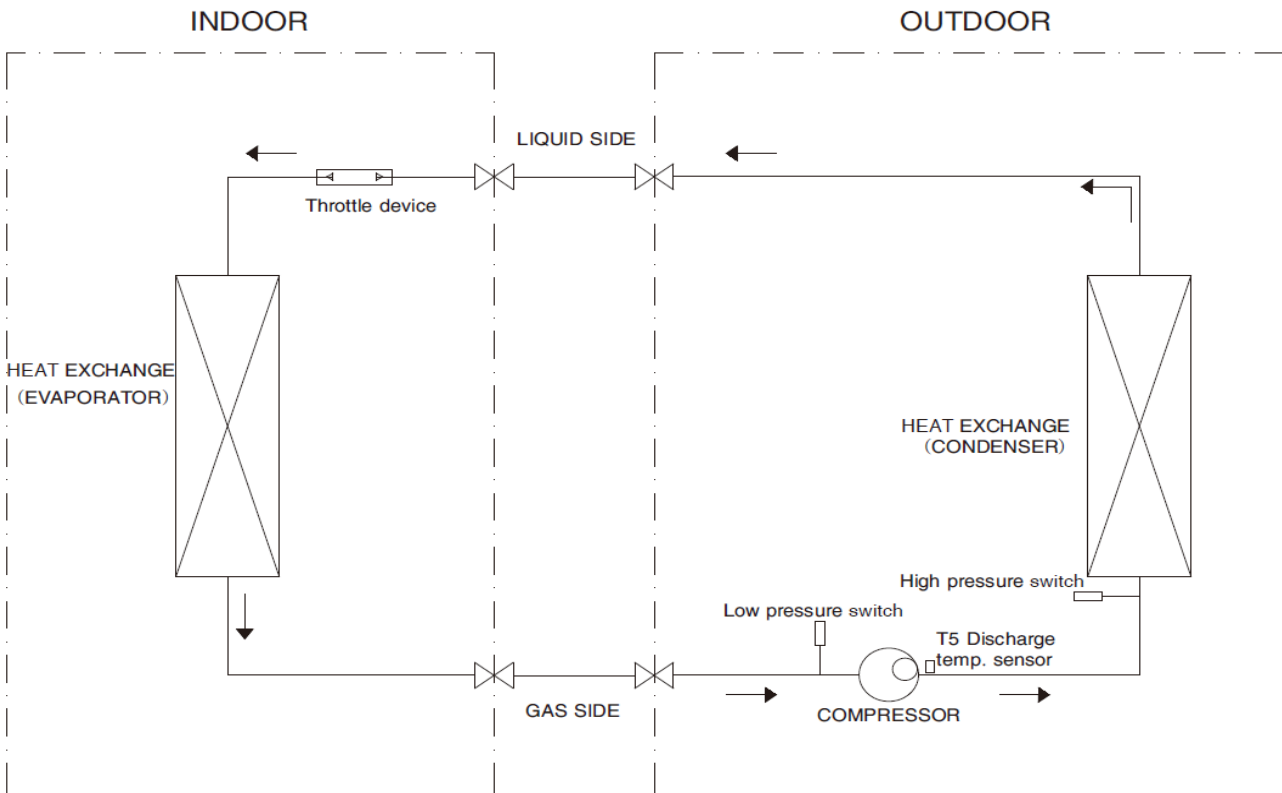

Part 4 Unit maintenance

1 .Fault indicator of indoor unit.....	23
2. Fault indicator of outdoor unit.....	24
3 .Flow chart of troubleshooting	25

1. Fault indicator of indoor unit

The meaning of the fault indicator:

Display mode	Status description
Green light always on	No system alarm and error, normal standby
Red light always on	Evaporator tube temperature sensor(T 2) failure
Green light always on, yellow light flashing	Evaporator high and low temperature protection
Green light flashing	System is in normal operating status

2. Fault indicator of outdoor unit

The meaning of the fault indicator:

Display content		State description
No alarm: Green light flashes Yellow lights	Green light slow flash	Normal standby
	Green light normally on	Normal operation
System Alarm: Green light slow flash Yellow light flashing	(T3)Temperature sensor fault	Yellow light flashes 2 times every 8s
	(T5)Temperature sensor fault	Yellow light flashes 8 times every 8s
	Low pressure alarm	Yellow light flashes 6 times every 8s
	High pressure alarm	Yellow light flashes 1 times every 8s
	(T3)High temperature protection	Yellow light flashes 9 times every 8s
	High exhaust temperature protection	Yellow light flashes 5 times every 8s
System lock: Green light go out Yellow light normally on	3 high/low voltage protection in 20 minutes	It needs to be reenergized and it needs to work
	Exhaust temperature is too high for 3 times within 20 minutes	
	T3 high temperature protection 3 times within 20 minutes	

3.Flow chart of troubleshooting

3.1 Evaporator temperature sensor fault

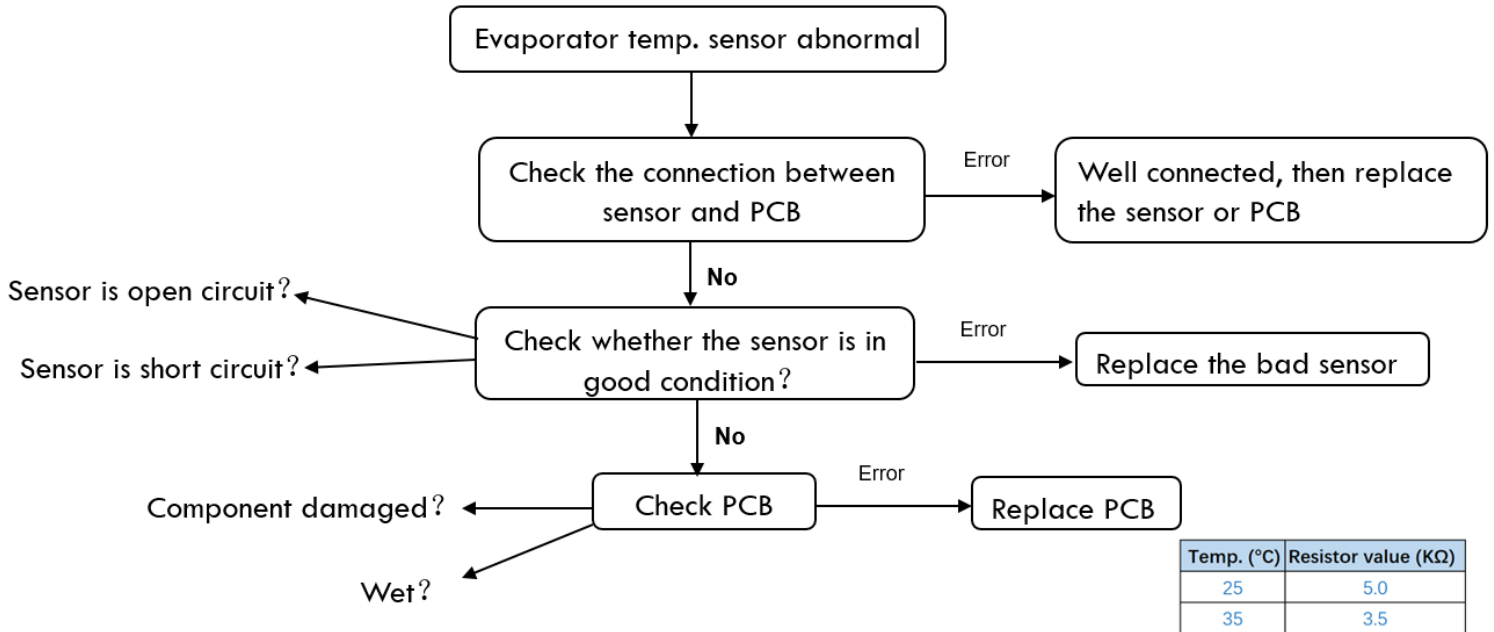

3.2 Evaporator high temperature protection(For heating mode)

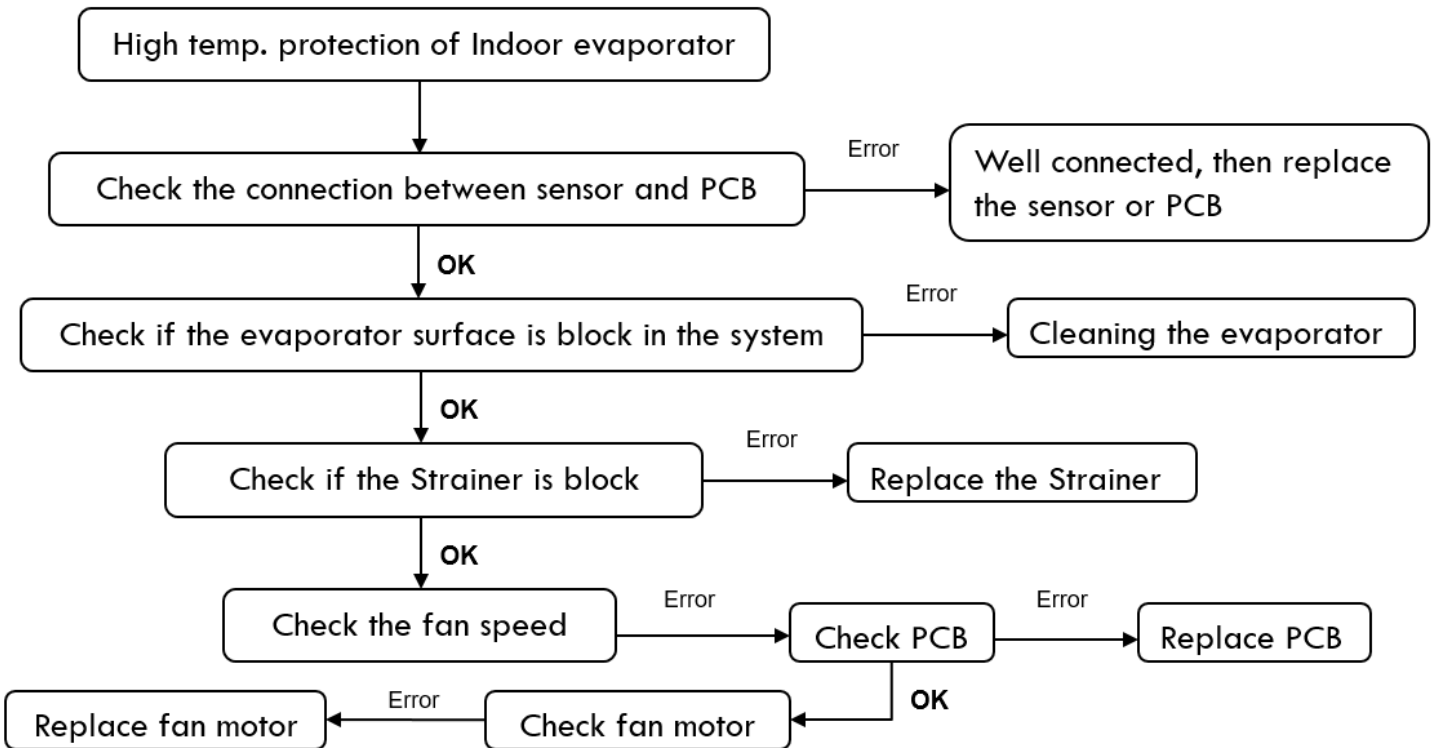

3.3 Evaporator low temperature protection(For cooling mode)

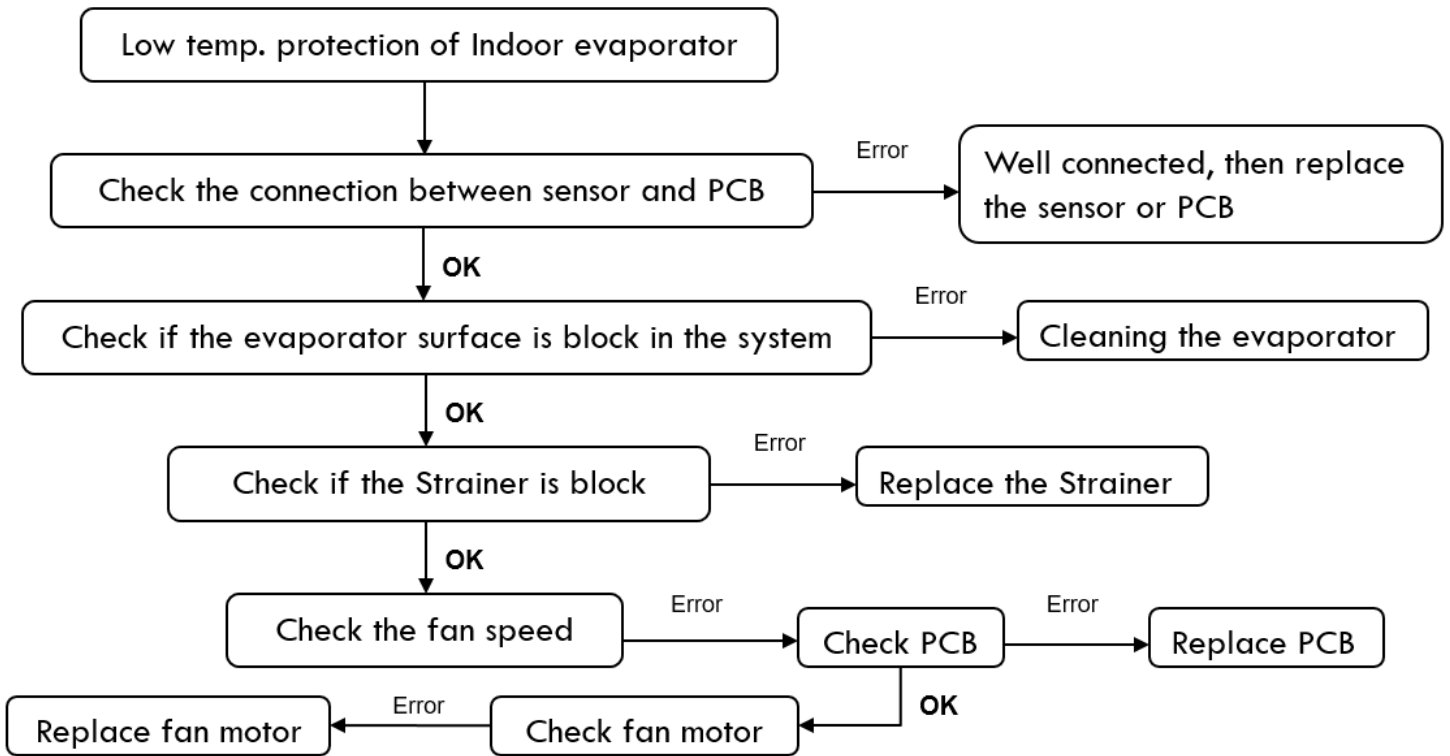

3.4 T3 Condenser Temperature sensor fault

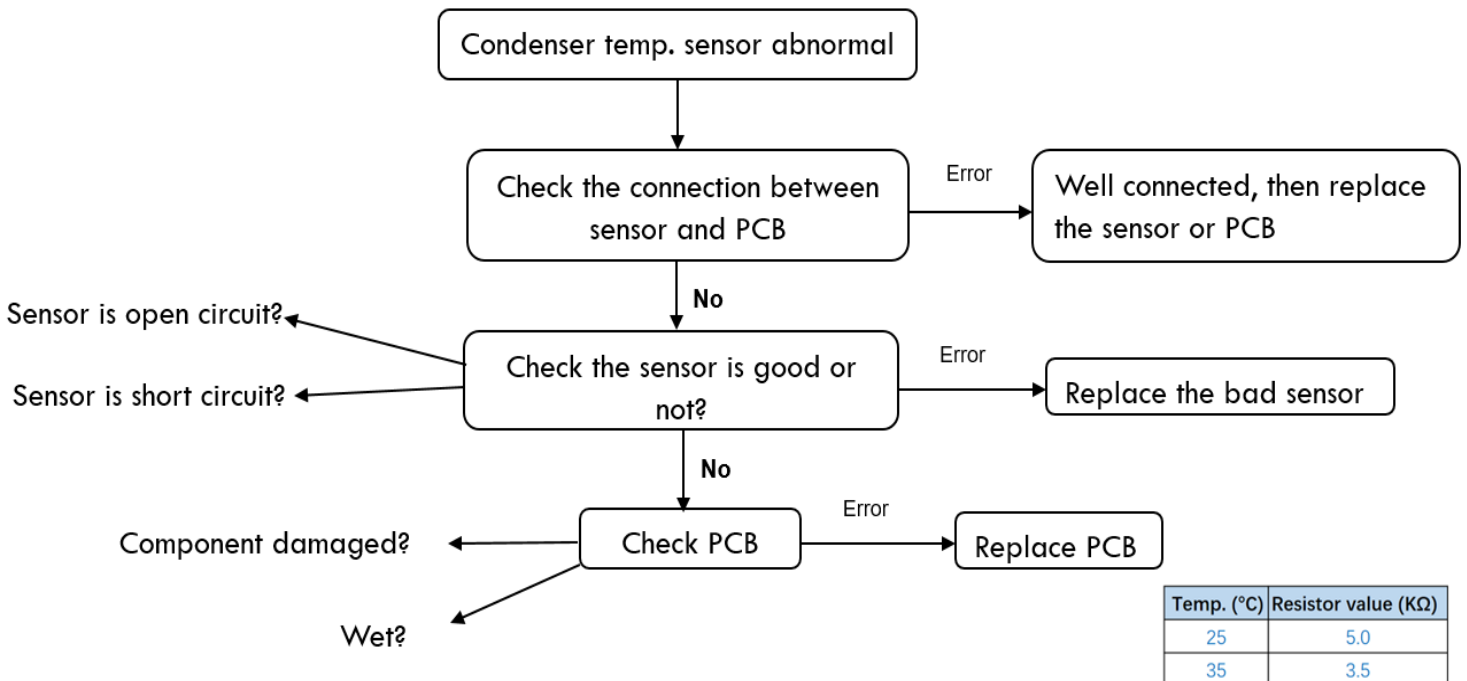

Temp. (°C)	Resistor value (KΩ)
25	5.0
35	3.5

3.5 T5 discharge temperature sensor fault

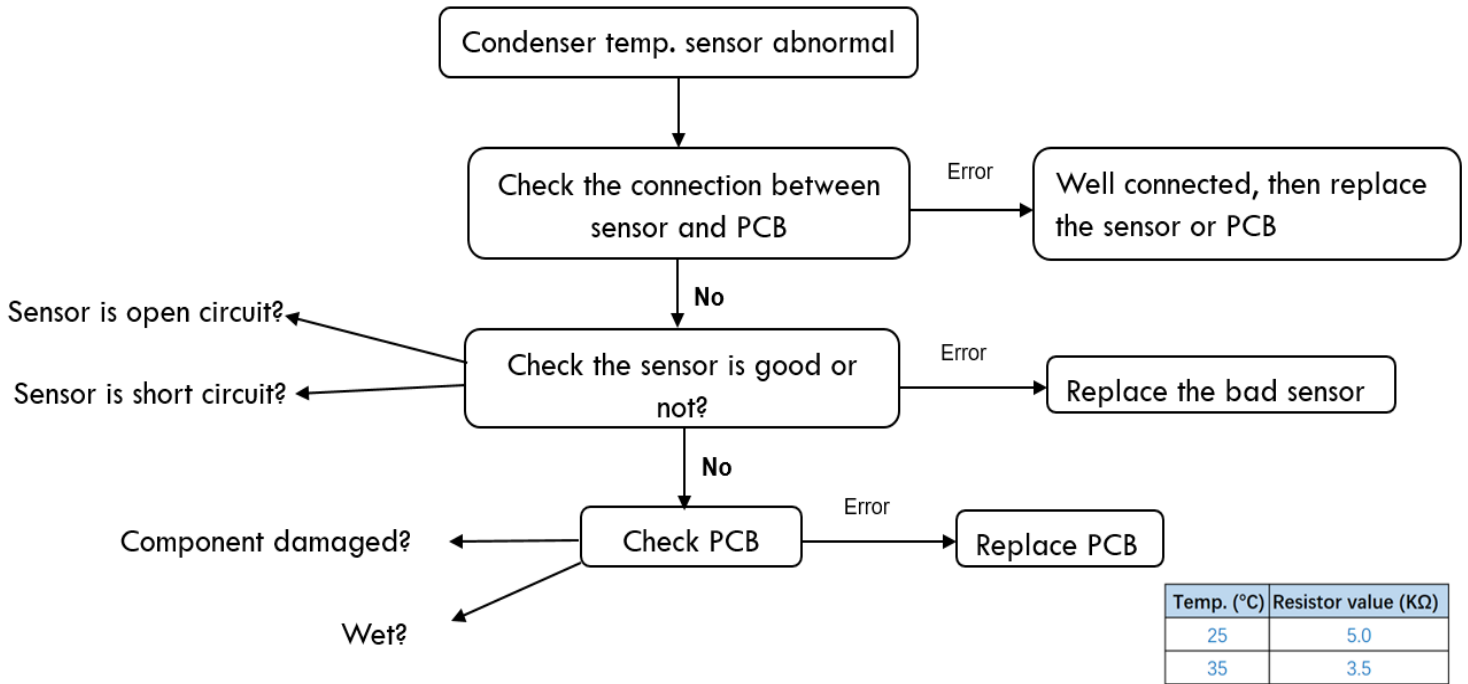

3.6 Low pressure alarm

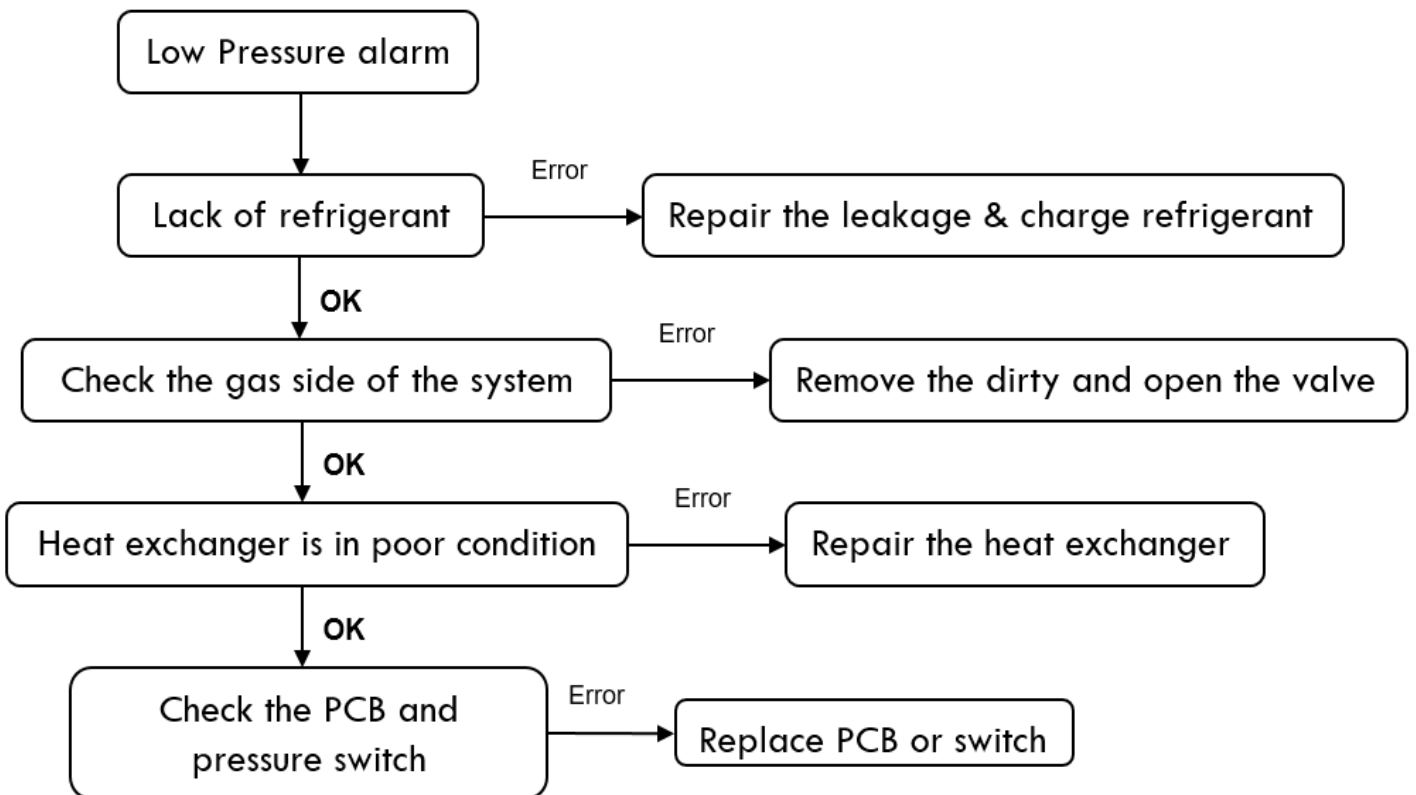

3.7 High pressure alarm

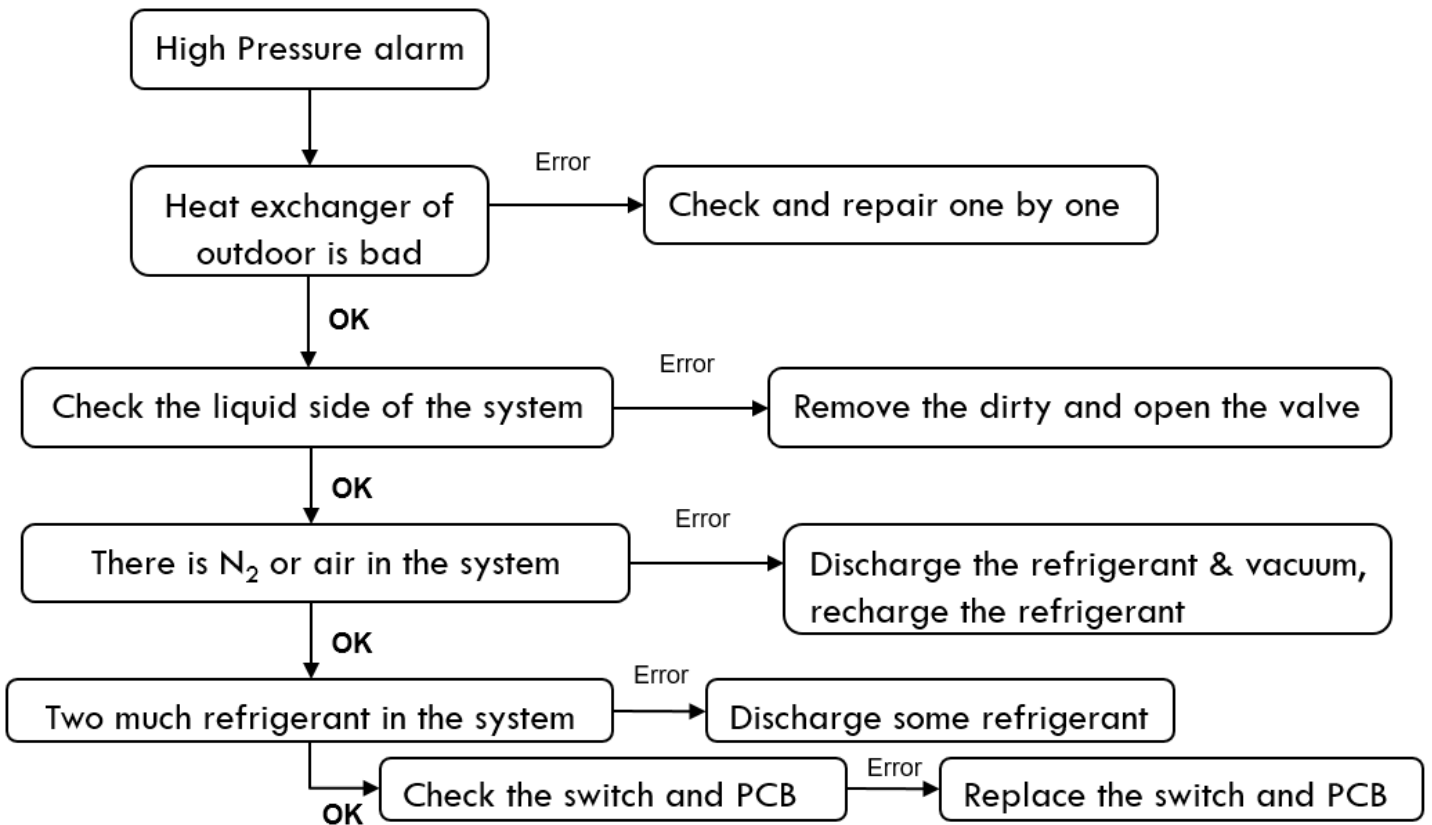

3.8 T3 High temperature protection

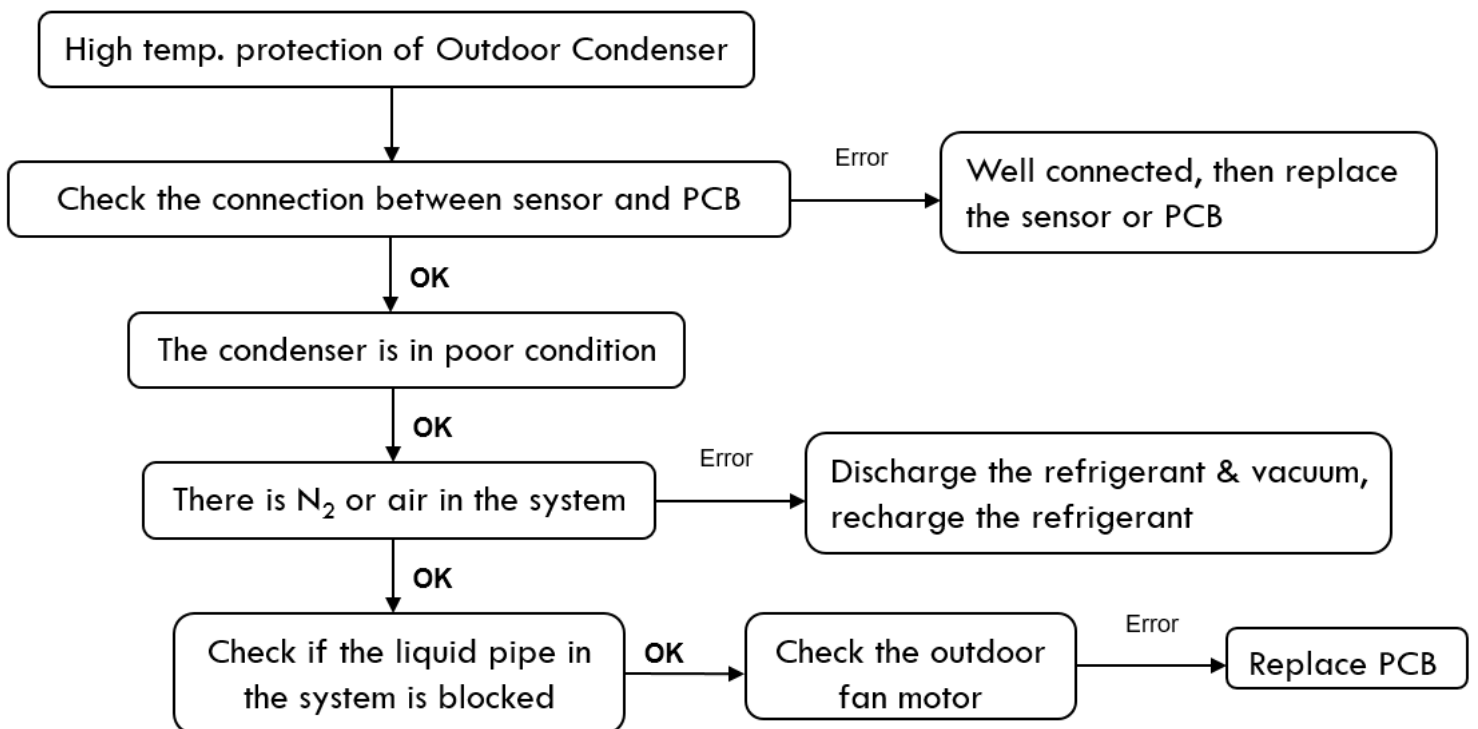

3.9 High exhaust temperature protection

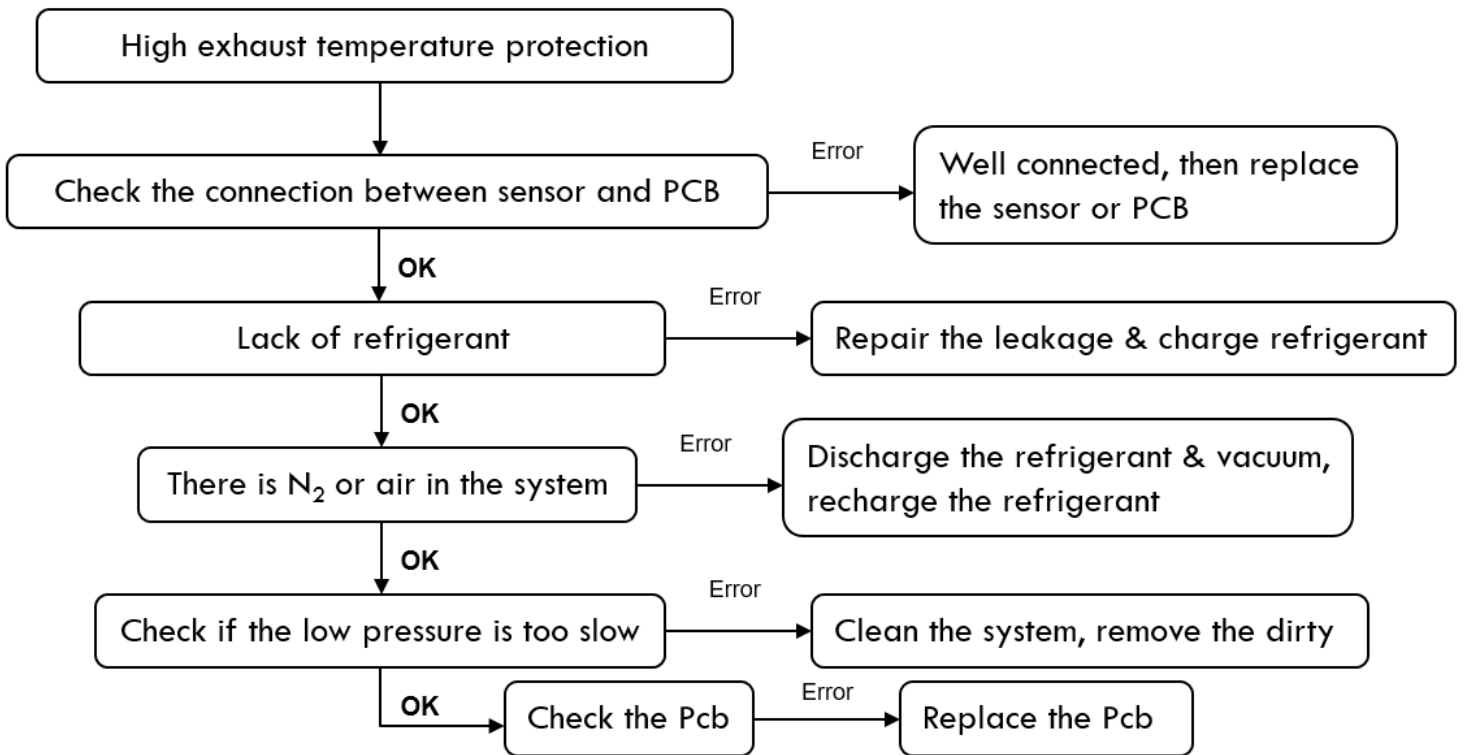



**ENVIRONMENTAL
TECHNOLOGIES LLC.**

17702 Mitchell North, #101
Irvine, CA. 92614 .USA
Tel: 714 795 2830
Fax: 714 966 1646
info@otecomega.com
www.otecomega.com

OTECTM
AIR CONDITIONING

Showroom & Technology Center
11380 Interchange Circle North
Miramar, FL 33025 .USA
Tel: 305 901 1270
Fax: 954 212 8280
info@otecomega.com
www.otecomega.com

SCVC4S(H)2A-SM1G1122