

VEUA-G Series VRF Air Handler

Technical Manual

208~230V/1/60Hz



Contents

1.Nomenclature.....	3
2.External Appearance	3
3.Features	4
4.Specification	6
5.Dimension	7
6.Service Space	8
7.Wiring Diagrams	9
8.Exploded View	10
9.The Specification of Wiring	12
10.Troubleshooting	12

1. Nomenclature

Indoor unit

Model name	Dimension(W×H×D) (mm)	Power supply
VEUA024Q2A-GCV071	774*520*460	208~230V-1Ph-50/60Hz
VEUA036Q2A-GCV105	774*520*460	208~230V-1Ph-50/60Hz
VEUA060Q2A-GCV160	970*550*500	208~230V-1Ph-50/60Hz

2. External Appearance

Indoor unit



3.Features

“A” shape coils, constructed with copper tubing and enhanced aluminum fins

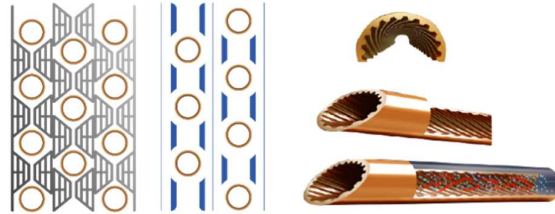

For outdoor units with 48-60K capacity, DC fan motors with three speeds are used to offer various options for air flow based on specific needs. These motors are enclosed in a large scroll case that provides a robust airflow. Moreover, the motor is coated with a thermal insulator to ensure its safe operation.

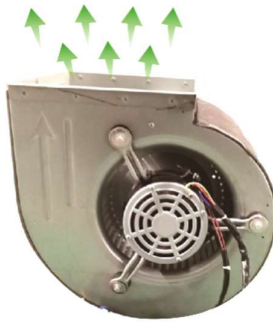

Use **TXV** as expansion device (18 SEER air handler)

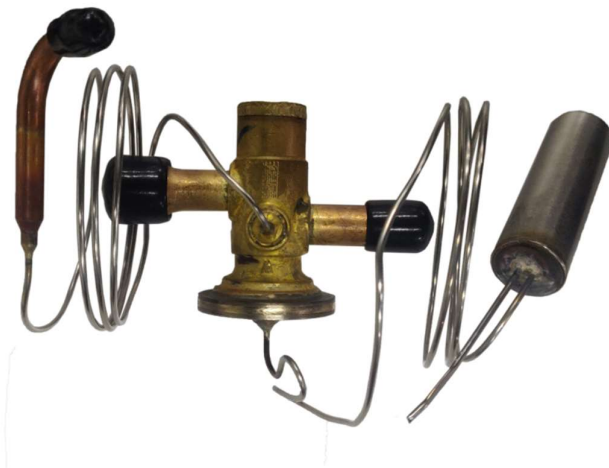

Detachable air filter for cleaning or renewal

Versatile 4-way convertible design for vertical up airflow, horizontal right airflow.

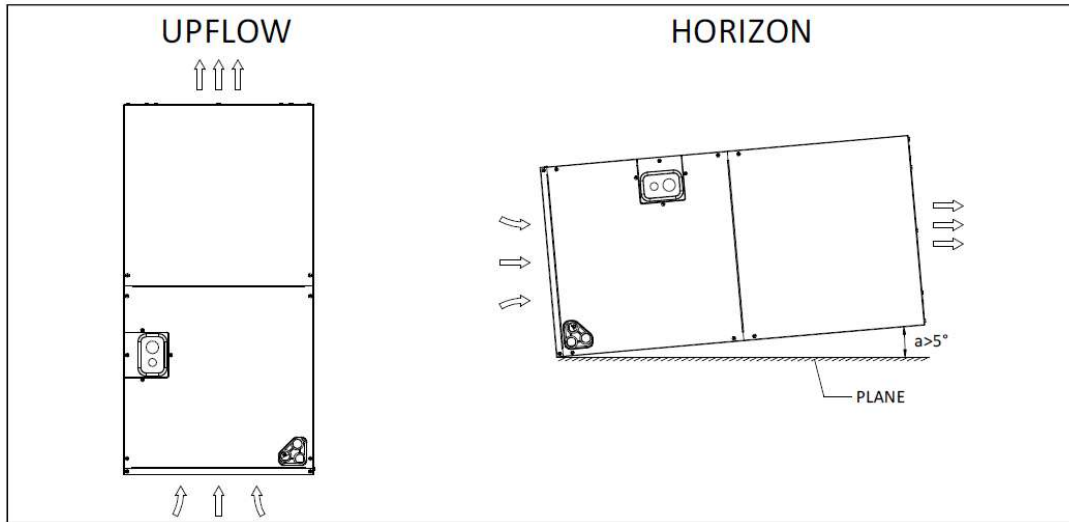

Wide operating temperature range

Mode	Cooling operation	Heating operation	Drying operation
Room temperature	17°C~32°C (62°F~90°F)	0°C~30°C (32°F~86°F)	17°C~32°C (62°F~90°F)
Outdoor temperature	18°C~43°C (64°F~109°F)	-7°C~24°C (20°F~76°F)	18°C~43°C (64°F~109°F)
	-7°C~43°C (20°F~109°F) : For the models with low temperature cooling system		18°C~52°C (64°F~126°F) : For special tropical models
	18°C~52°C (64°F~126°F) : For special tropical models		

CAUTION:

1. If air conditioner is used outside of the above conditions, Certain safety protection features may come into operation and cause the unit to function abnormally.
2. Room relative humidity less than 80%. If the air conditioner operates in excess of this figure, the surface of the air conditioner may attract condensation. Please sets the vertical air flow 1ouver to its maximum angle(vertically to the floor), and set HIGH fan mode.
3. Optimum performance will be achieved within these operating temperature.

4.Specification

Model			VEUA024Q2A-GCV071	VEUA036Q2A-GCV105	VEUA060Q2A-GCV160
BOM			820044600001	820044600002	820044600003
Power supply			208-230V/1N/60Hz	208-230V/1N/60Hz	208-230V/1N/60Hz
Capacity	Cooling	kW	7.1	10.5	16
	Heating	kW	8	11.5	18
Power Input		W	290	290	517
Fan motor	Model		YDK130-6G03	YDK130-6G03	YDK-350F-6P3
	Type		AC	AC	AC
	Brand		Kangbao	Kangbao	Kangbao
	Capacitor	μF	-	-	-
	Speed (Hi/Low)	r/min	910/780	910/780	930/880
Indoor coil	Number of rows		2	2	2
	Fin type		Hydrophilic Aluminum	Hydrophilic Aluminum	Hydrophilic Aluminum
	Tube diameter and type	mm	Ø7,Innergroove tube	Ø7,Innergroove tube	Ø7,Innergroove tube
Air flow (High speed)		m ³ /h	1500	1500	2500
External static pressure		Pa	25	37	50
Sound pressure level		dB(A)	51~54	51~54	57~60
Body	Dimension (W×H×D)	mm	774x520x460	774x520x460	970x550x500
	Packing (W×H×D)	mm	834x520x565	834x520x565	1030x560x595
	Net/Gross weight	kg	36/39	36/39	48/52
Refrigerant type			R410A	R410A	R410A
Throttle type			EXV	EXV	EXV
Design pressure			MPa	4.5	4.5
Liquid pipe / Gas pipe			mm	Ø9.52/ Ø15.88	Ø9.52/ Ø15.88
Connecting wire	Power wire	mm ²	2.5*2+2.5(L≤20m)	2.5*2+2.5(L≤20m)	2.5*2+2.5(L≤20m)
			4*2+2.5(20m<L≤50m)	4*2+2.5(20m<L≤50m)	4*2+2.5(20m<L≤50m)
	Signal wire	mm ²	0.75*2 shield	0.75*2 shield	0.75*2 shield
Drainage water pipe (Outer diameter)		mm	Ø20	Ø20	Ø20
Controller	Standard		Wired controller	Wired controller	Wired controller
Operation temperature		°C	16~32	16~32	16~32

Notes:

1. Nominal cooling capacities are based on the following conditions:

Indoor temp: 27°CDB, 19°CWB; Outdoor temp: 35°CDB; Equivalent ref. piping: 5m (horizontal)

1. Actual noise level may differ, depending on the room structure, etc., since these noise values are from an anechoic room.

5.Dimension

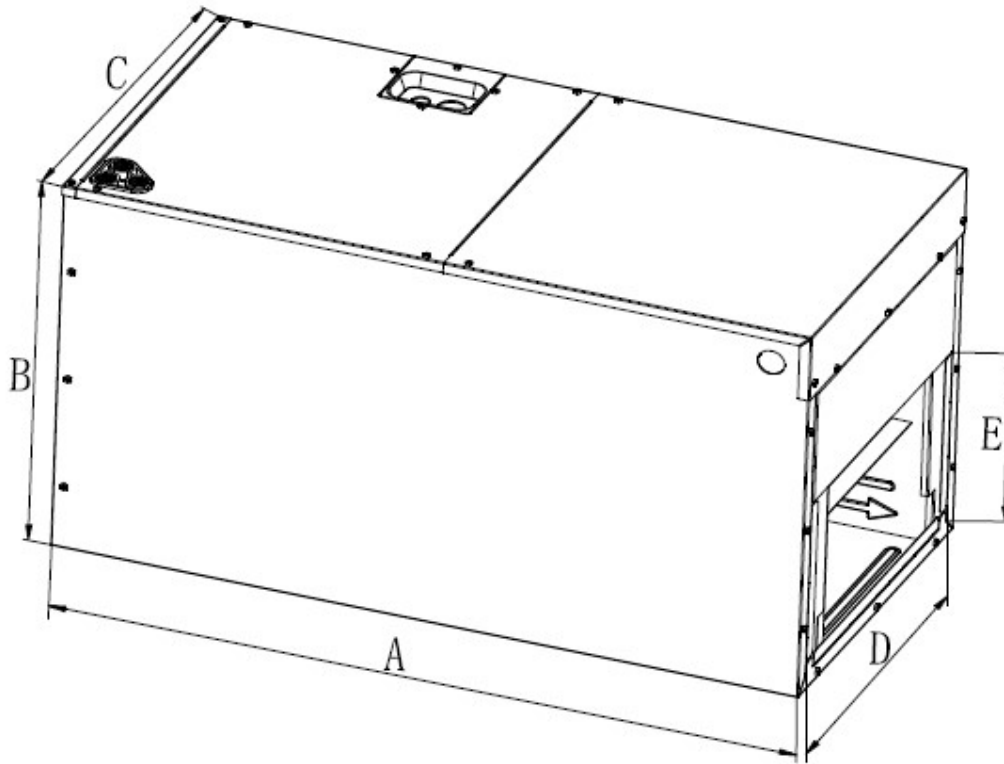

MODEL	Dimensions(mm)				
	A(Height)	B(Depth)	C(Width)	D	E
18	774	520	460	414	245
24	774	520	460	414	245
36	774	520	460	414	245
48	970 (1160)	550	500	454	266
60	970 (1160)	550	500	454	266

Note: (1160) is custom model's height.

6. Service Space

The indoor unit should be installed in a location that meets the following requirements:
INSTALLATION NOTES: .

- a) When up hand discharge , how to trap or plug all drains is see the left Figure.
- b) When right hand discharge , how to trap or plug all drains is see the top Figure.
- c) The seal-plugs are supplied as accessories , and be screwed tightly only with hand.

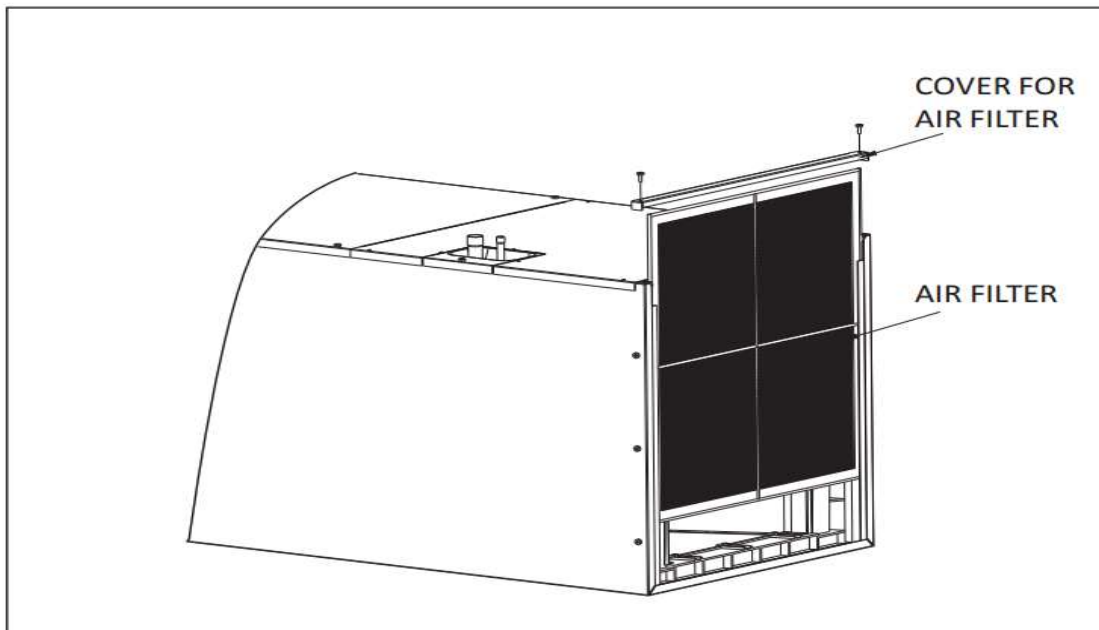
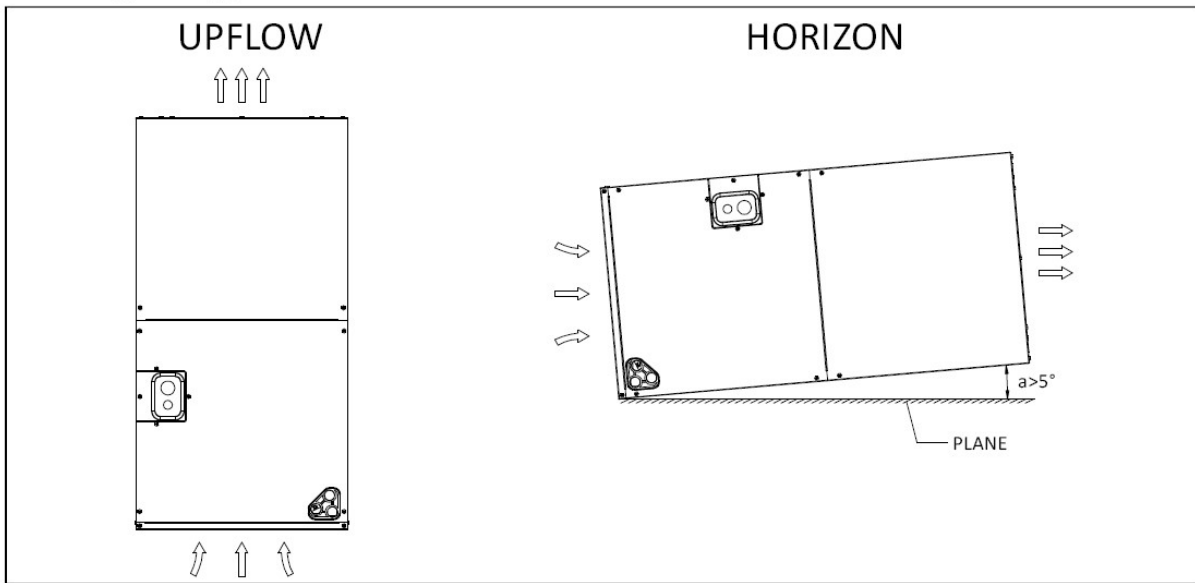

7.Wiring Diagrams

VEUA024(36,60)Q2A

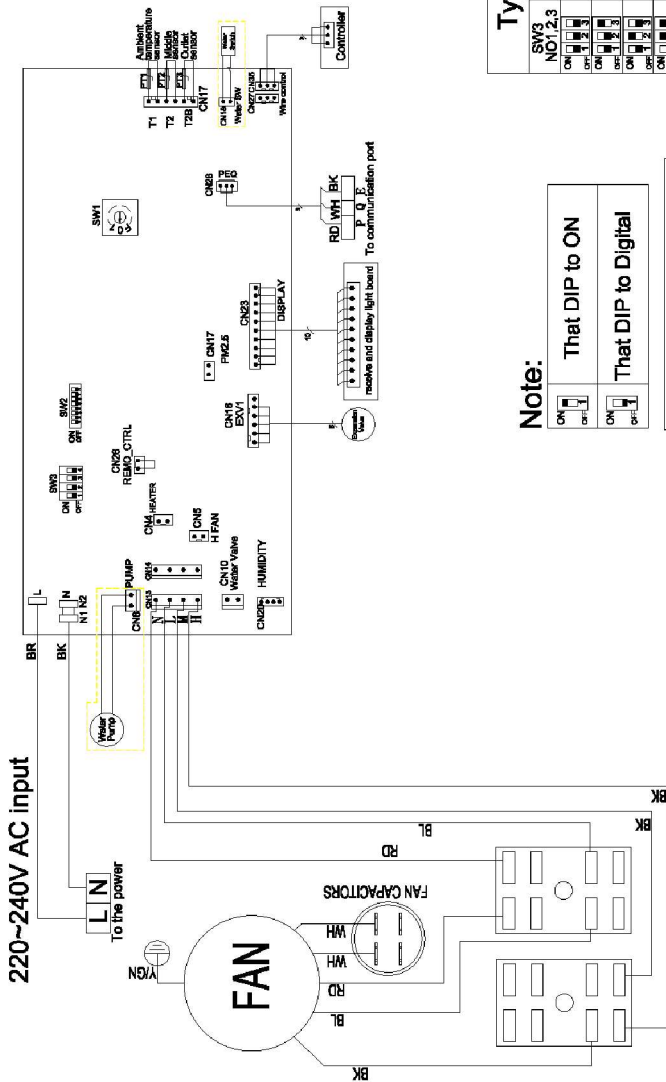

Refrigeration temperature compensation temperature value select bit	
SW2 NO.1	3°C Factory default
	1°C

Heating temperature compensation temperature value select bit	
SW2 NO.2	6°C Factory default
	2°C

Anti-cold wind off the fan temperature selection bit	
SW2 NO.3&4	Temperature selection
	15°C
	20°C
	24°C
	26°C

Heating stop the fan time to chooset	
SW2 NO.5	4min Factory default
	8min

SW3 NO.1,2,3	Type
<input type="checkbox"/> ON <input type="checkbox"/> OFF	Normal duct unit
<input type="checkbox"/> ON <input type="checkbox"/> OFF	Fresh air processor
<input type="checkbox"/> ON <input type="checkbox"/> OFF	One-way cassette
<input type="checkbox"/> ON <input type="checkbox"/> OFF	Two-way cassette
<input type="checkbox"/> ON <input type="checkbox"/> OFF	HRV
<input type="checkbox"/> ON <input type="checkbox"/> OFF	10HP floor standing unit
<input type="checkbox"/> ON <input type="checkbox"/> OFF	Reserve

Mode Select bits	
SW3 NO.4	Automatic Address-sing mode and (Factory default)
NO.4	Test mode (to allow clear address)

According to the contract custom power lost memory functions	
SW2 NO.6	Power lost memory (Factory default)
NO.6	No power-down memory

Note:
That DIP to ON
That DIP to Digital

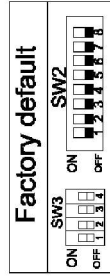

The power (PH) of indoor units can be set through DIP switch SW1(16-bit disc DIP) on the indoor control panel before delivery, the detailed information is as follows:

HP	0.8	1	1.2	1.7	2	2.5	3	3.2	4	5	6
Power	18/22	25/26/28	32/35/36	40/45/46	50/51/56	60/63/66/71	80	88/90	100/105/110/112	120/125/140/150/160	
Dial code	0	1	2	3	4	5	6	7	8	9	A

NOTE:

1. The factory default WATER-SW CN2 need cables short circuit
2. The water pump outlet are connected by a field installation

8.Exploded View

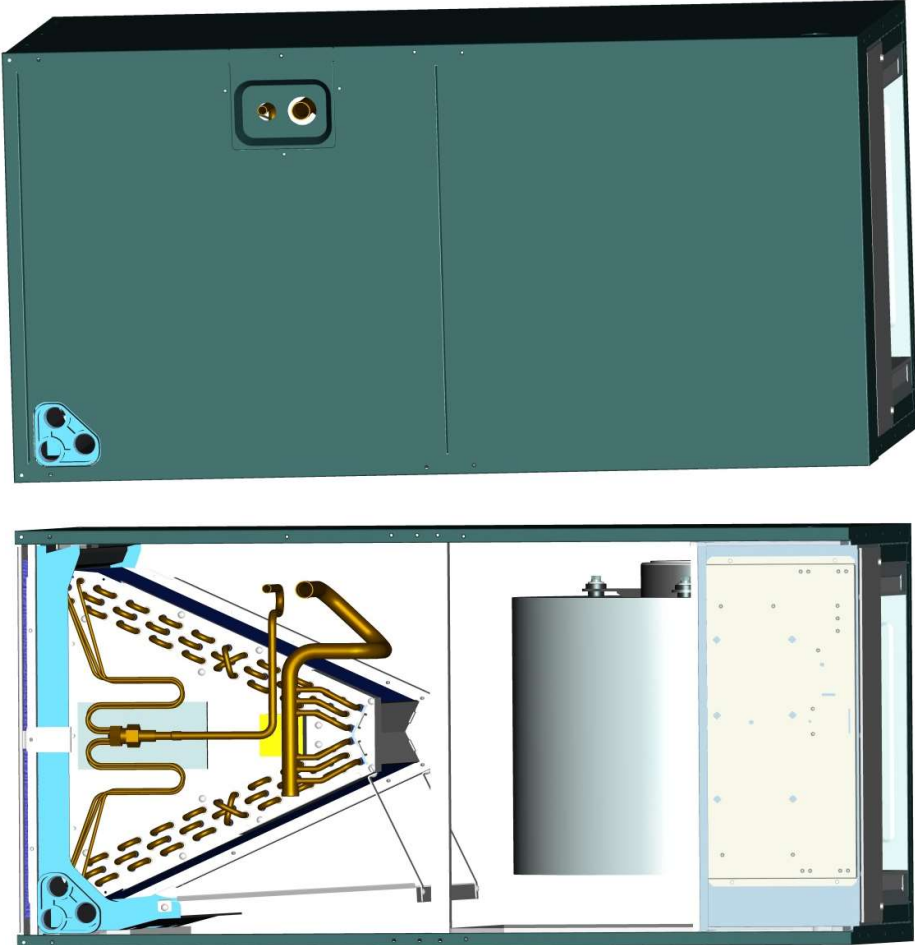

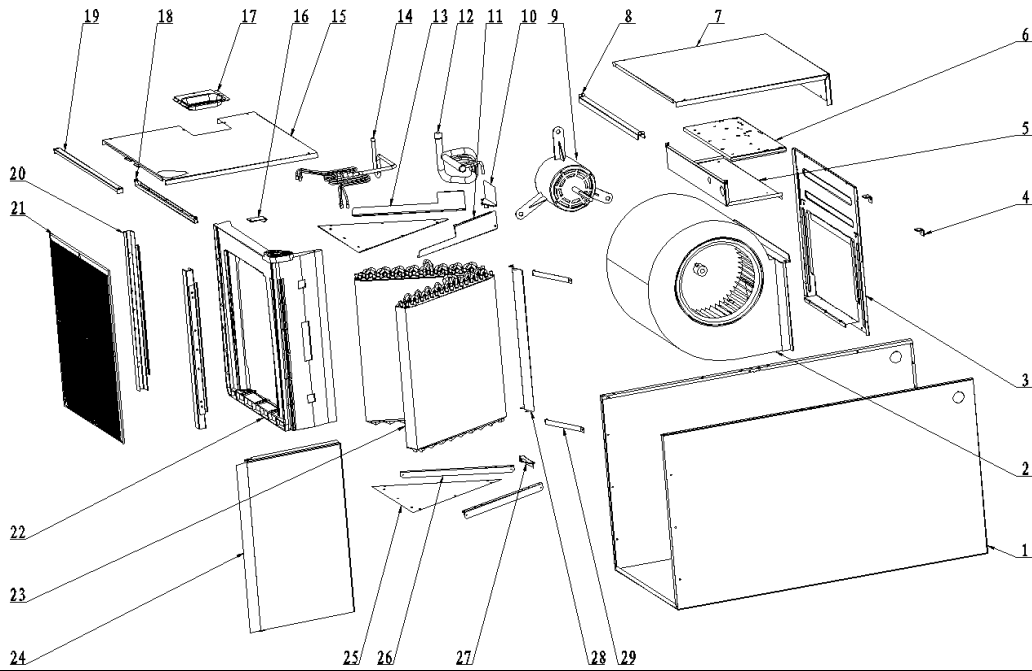

No.	Part Name	Qua.	No.	Part Name	Qua.
1	Chassis assembly	1	14	Diverter Assembly	1
2	Right Volute Wind Wheel	1	15	Lower side plate assembly	1
3	Fan Motor Fixing plate	1	16	Water pan fixed block	1
4	Wind Wheel Fixed Block	2	17	Pipe Cover plate assembly	1
5	Electronic Control Fixing Plate Welding Assembly	1	18	Supporter	1
6	Electronic Control Components	1	19	Filter Cover plate	1
6.1	Electronic Control Mounting Plate	1	20	Water pan supporter assembly	2
6.2	Main Board	1	21	Filter	1
6.3	Temperature Sensor	1	22	Water pan# 1	1
6.4	Fan Motor Capacitor	1	23	Evaporator	2
7	Upper side plate assembly	1	24	Water pan# 2	1
8	Middle Cross Beam Assembly	1	25	Evaporator Baffle	2
9	Indoor Motor	1	26	Evaporator Water Baffle #1	2
10	Evaporator Fixing Plate #2	1	27	Evaporator Fixing Plate #1	1
11	Evaporator Water Baffle #2	1	28	Evaporator Junction Plate	1
12	Air header Assembly	1	29	Water pan brace	1
13	Evaporator Water Baffle #1	1			

9.The Specification of Wiring

Note:

The cross-section areas of wires or lines should not be less than the corresponding ones listed in the table below; Besides, if the power wires is quite long from the unit, please choose the windings with larger cross-section areato guarantee the normal power supply.

Name Model	Outdoor power supply line (quantity , diameter) H05RN-F	Indoor power supply line (quantity, diameter) H05VV-F	Indoor /outdoor connection line (quantity, Diameter)	Power supply method
Single phase 5.3kW model	/	3 x 2.5mm ²	4 x 2.5mm ²	Indoor Power Supply
Single phase 7.0 kW model	/	3 x 2.5mm ²	4 x 2.5mm ²	Indoor Power Supply
Single phase 10.5 kW model	3 x 4mm ²	3 x 1.5mm ²	3 x 1mm ²	Indoor / outdoor separately powered
3-phase ≥10.5kw model	5 x 2.5mm ²	3 x 1.5mm ²	3 x 1mm ²	Indoor / outdoor separately powered

10.Troubleshooting

The fault codes for indoor unit as follows:

Fault Description	4LED fault indication	Digital display	Wired remote display
Three-phase power phase sequence fault		E0	E0
Indoor and outdoor unit communication failure	Timing lights flash	E1	E1
Temperature sensor (T1) fault	Running lights flash	E2	E2
Pipe temperature sensor in the evaporator (T2) fault	Running lights flash	E3	E3
Pipe temperature sensor in the evaporator (T2B) fault	Running lights flash	E4	E4
Outdoor unit failure	Warning lights flash slowly	E5	E5
The indoor unit EEPROM fault	Defrost lights flash slowly	E7	E7
Water over protection	Warning lights flash	EE	EE
Indoor unit with line controller communication failure		E9	E9
Note: The flash frequency for each of the above indicator is 2.5Hz, slow flashing frequency is 1Hz			



OMEGA
ENVIRONMENTAL
TECHNOLOGIES LLC.

17702 Mitchell North, #101
Irvine, CA. 92614 .USA
Tel: 714 795 2830
Fax: 714 966 1646
info@omegavrf.com
www.omegavrf.com

OTECTM
AIR CONDITIONING

Showroom & Technology Center
11380 Interchange Circle North
Miramar, FL 33025 .USA
Tel: 305 901 1270
Fax: 954 212 8280
info@otecomega.com
www.otecomega.com

VEUAQ2A-TM2G0323