

VECT Series Two Way Cassete VRF Technical Manual

220-240V/1/50Hz

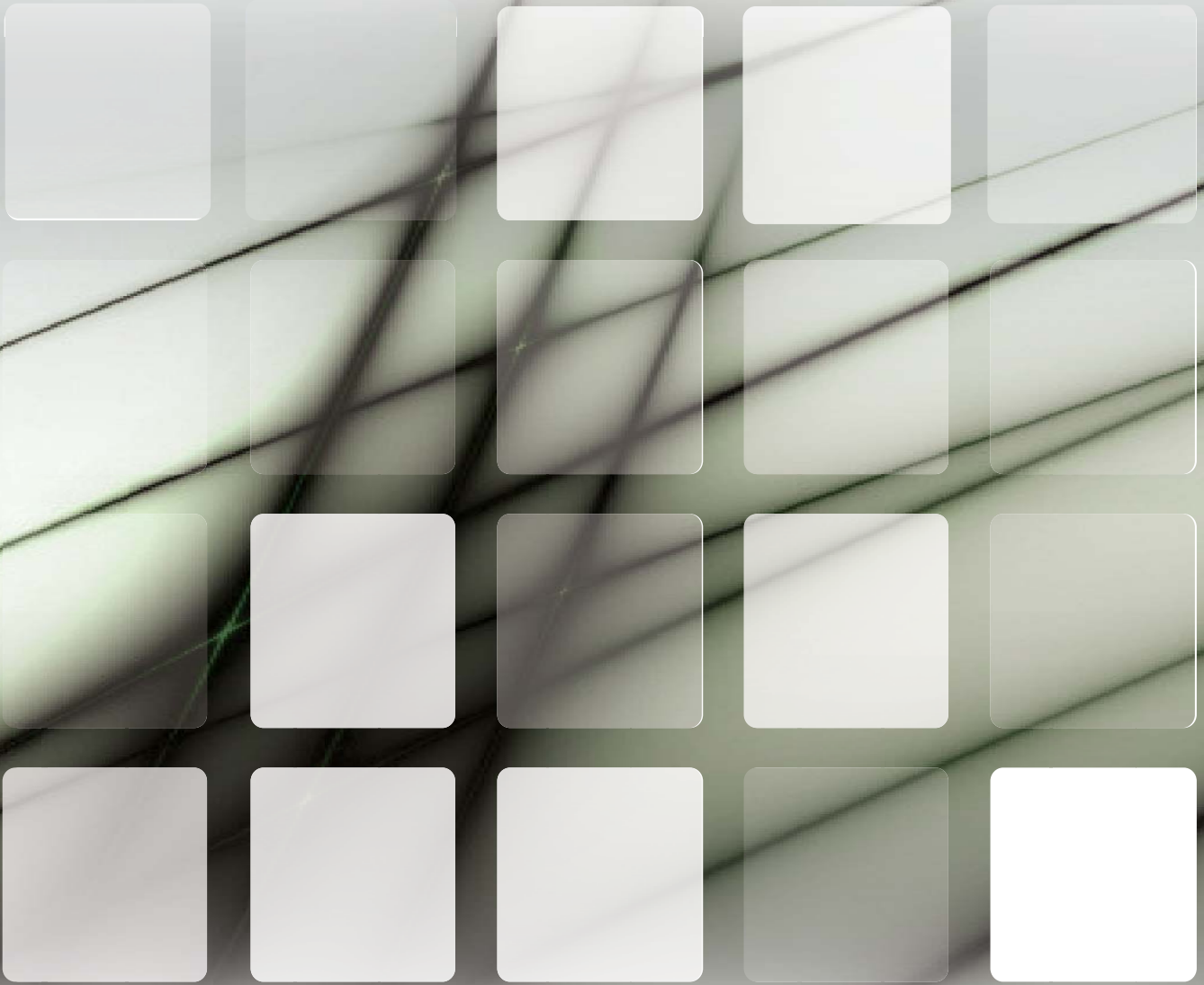

Content

- 1. External appearance**
- 2. Specifications**
- 3. Dimensions**
- 4. Service space**
- 5. Piping diagram**
- 6. Wiring diagram**
- 7. Capacity tables**
- 8. Electric characteristics**
- 9. Sound pressure levels**
- 10. Accessories**
- 11. Exploded view**

1. Specifications

Model			VECT015Q3A-GWV045	VECT019Q3A-GWV056
Power supply			220-240V/1PH/50Hz	220-240V/1PH/50Hz
Capacity	Cooling	kW	4.5	5.6
	Heating	kW	5.0	6.3
Power input		kW	0.07	0.07
Fan motor	Model		YSK100-55F-4P3	YSK100-55F-4P3
	Type		AC	AC
	Brand		xinjun/kangbao	xinjun/kangbao
	Capacitor	μF	3	3
	Speed (Hi/Med/Low)	r/min	1290/970/810/710	1290/970/810/710
	Speed (Hi/Med/Low)	r/min	1310/1000/790/730	1310/1000/790/730
Indoor coil	Number of rows		2	2
	Fin type		Hydrophilic Aluminum	Hydrophilic Aluminum
	Tube diameter and type	mm	Ø7,Innergroove Tube	Ø7,Innergroove Tube
Air flow		m ³ /h	800	800
Sound pressure level		dB(A)	36~42	36~42
Body	Dimension (W×H×D)	mm	1068×517×310	1068×517×310
	Packing (W×H×D)	mm	1205×620×350	1205×620×350
	Net/Gross weight	kg	34.5/38.7	34.5/38.7
Panel	Dimension (W×H×D)	mm	1178×630×44	1178×630×44
	Packing (W×H×D)	mm	1205×655×75	1205×655×75
	Net/Gross weight	kg	5/7	5/7
Refrigerant type			R410A	R410A
Throttle type			Electrical expansion valve	Electrical expansion valve
Design pressure		MPa	4.5	4.5
Liquid pipe / Gas pipe		mm	Ø6.35/ Ø12.70	Ø6.35/ Ø12.70
Connecting wire	Power wire	mm ²	2×2.5+2.5mm ² (below 20m) 2×4.0+2.5mm ² (below 50m)	2×2.5+0.25mm ² (below 20m) 2×4.0+2.5mm ² (below 50m)
	Signal wire	mm ²	0.75	0.75
Drainage water pipe (Outer diameter)		mm	Ø20	Ø20
Controller	Standard		Remote controller	Remote controller
	Optional		Wired controller	Wired controller
Operation temp		°C	16~32	16~32

Model			VECT024Q3A-GWV071	VECT027Q3A-GWV080
Power supply			220-240V/1PH/50Hz	220-240V/1PH/50Hz
Capacity	Cooling	kW	7.1	8
	Heating	kW	8	9
Power input		kW	0.1	0.1
Fan motor	Model		YSK100-68F-4P3	YSK100-68F-4P3
	Type		AC	AC
	Brand		xinjun/kangbao	xinjun/kangbao
	Capacitor	μF	3.5	3.5
	Speed	r/min	1360/1150/900/780	1360/1150/900/780
	Speed	r/min	1370/1180/920/800	1370/1180/920/800
Indoor coil	Number of rows		2	2
	Fin type		Hydrophilic Aluminum	Hydrophilic Aluminum
	Tube diameter and type	mm	Ø7, Innergroove Tube	Ø7, Innergroove Tube
Air flow		m ³ /h	1120	1120
Sound pressure level		dB(A)	40~46	40~46
Body	Dimension (W×H×D)	mm	1308×517×310	1308×517×310
	Packing (W×H×D)	mm	1445×620×350	1445×620×350
	Net/Gross weight	kg	41.2/45.6	41.2/45.6
Panel	Dimension (W×H×D)	mm	1420x630x44	1420x630x44
	Packing (W×H×D)	mm	1445×655×75	1445×655×75
	Net/Gross weight	kg	6/8.5	6/8.5
Refrigerant type			R410A	R410A
Throttle type			Electrical expansion valve	Electrical expansion valve
Design pressure		MPa	4.5	4.5
Liquid pipe / Gas pipe		mm	Ø9.52/ Ø15.88	Ø9.52/ Ø15.88
Connecting wire	Power wire	mm ²	2×2.5+2.5mm ² (below 20m) 2×4.0+2.5mm ² (below 50m)	2×2.5+0.25mm ² (below 20m) 2×4.0+2.5mm ² (below 50m)
	Signal wire	mm ²	0.75	0.75
Drainage water pipe (Outer diameter)		mm	Ø20	Ø20
Controller	Standard		Remote controller	Remote controller
	Optional		Wired controller	Wired controller
Operation temp		°C	16~32	16~32

Notes:

- 1) Nominal cooling capacities are based on the following conditions.
 - Outdoor temperature: 35°C DB
 - Return air temperature: 27°C DB, 19°C WB
 - Equivalent piping length: 8m in horizontal
- 2) Nominal heating capacities are based on the following condition.
 - Outdoor temperature: 7°C DB, 6°C WB
 - Return air temperature: 20°C DB
 - Equivalent piping length: 8m in horizontal
- 3) Sound pressure level: Semi-anechoic chamber conversion value, measured at a point 1 m in front of the unit at a height of 1.4 m.
- 4) The above data may be changed without notice for future improvement on quality and performance.

2. Dimensions

VECT015Q3A-GWV045, VECT019Q3A-GWV056, VECT024Q3A-GWV071, VECT027Q3A-GWV080

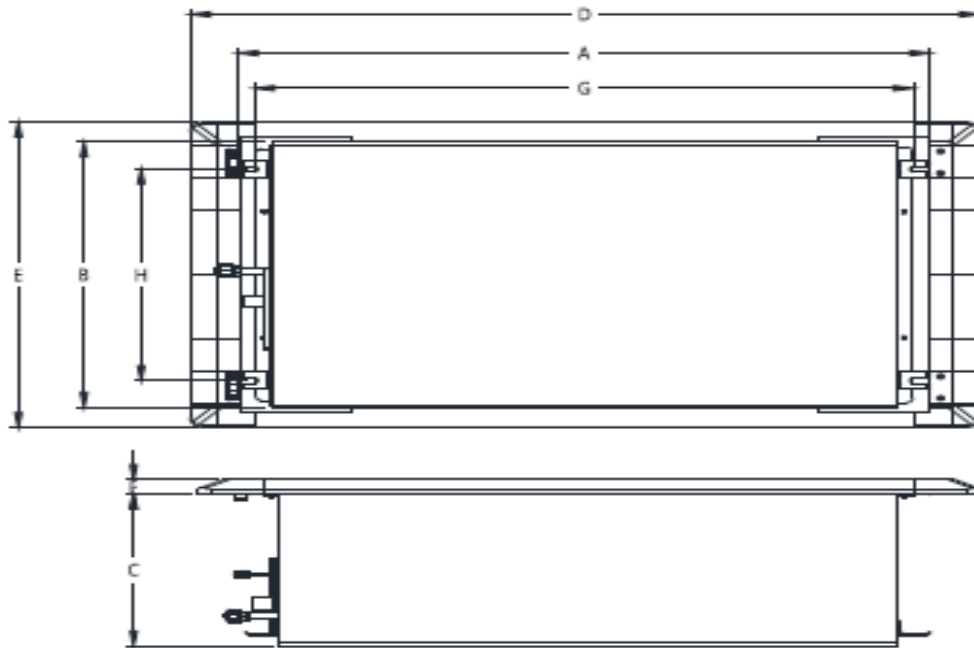

Size code Model of indoor unit	Body size			Panel size			Installing size	
	A	B	C	D	E	F	G	H
4.5kW~5.6kW	1092	548	315	1178	630	44	1006	437
7.1kW~8.0kW	1332	548	315	1420	630	44	1246	437

3. Service space

- 1 Provide enough space for installation and maintenance.
- 2 The ceiling is horizontal and the building construction can support indoor unit.
- 3 Ventilation is accessible and the site suffers from the minimal impact of extraneous air.
- 4 Air stream can spread to everywhere of the room.
- 5 Connecting pipe and drainpipe are easy to be extracted.
- 6 No direct radiation of heat.
- 7 The appliance must be installed 2,5m above floor.
- 8 The operating temperature for the unit are 23~32°C(Indoor).

⚠ Attention

- It may result in faults (if it's inevitable, please consult) if the unit is installed in the following places:
- Places where there is mineral oil like cutting oil.
- Places like seaside where there is much salt in the air.
- Places where there is aggressive gas like sulfur gas.
- Places like factory where power supply voltage severely fluctuates.
- In car or cabin.
- Places like kitchen which is full of oil gas and oil bloom.
- Places where there is strong electromagnetic wave.
- Please where there is inflammable gas or material.
- Please where acidic or alkaline gas evaporates.
- Other special environments.
- This series of air conditioning of comfort air conditioning, do not use computer, precision instrument, food, animals and plants, art and other special places.

As to space needed for installation of ceiling-style indoor unit, please refer to the following figure.

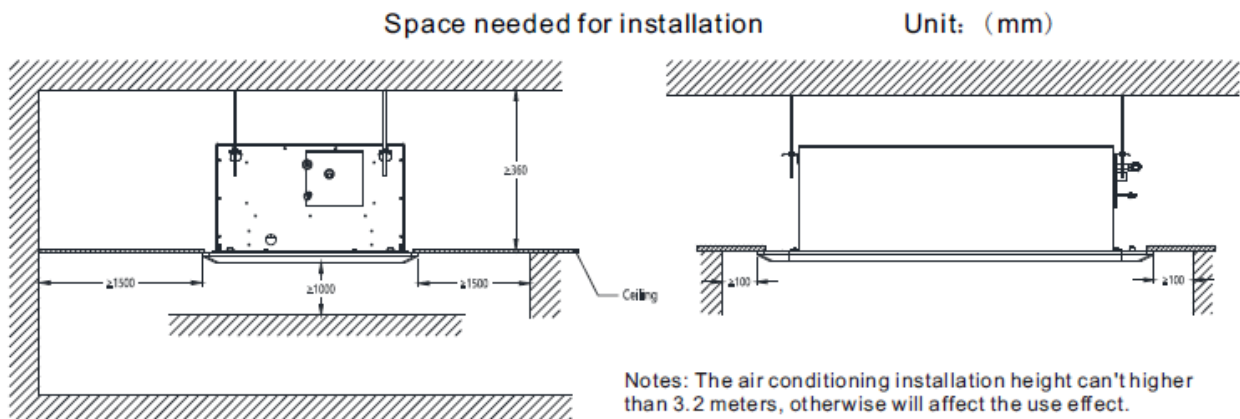

Notes: Actual sizes are subject to real products.

Note:

The air conditioning installation height can't higher than 3.2m, Otherwise will affect the use effect.

4. Piping diagram

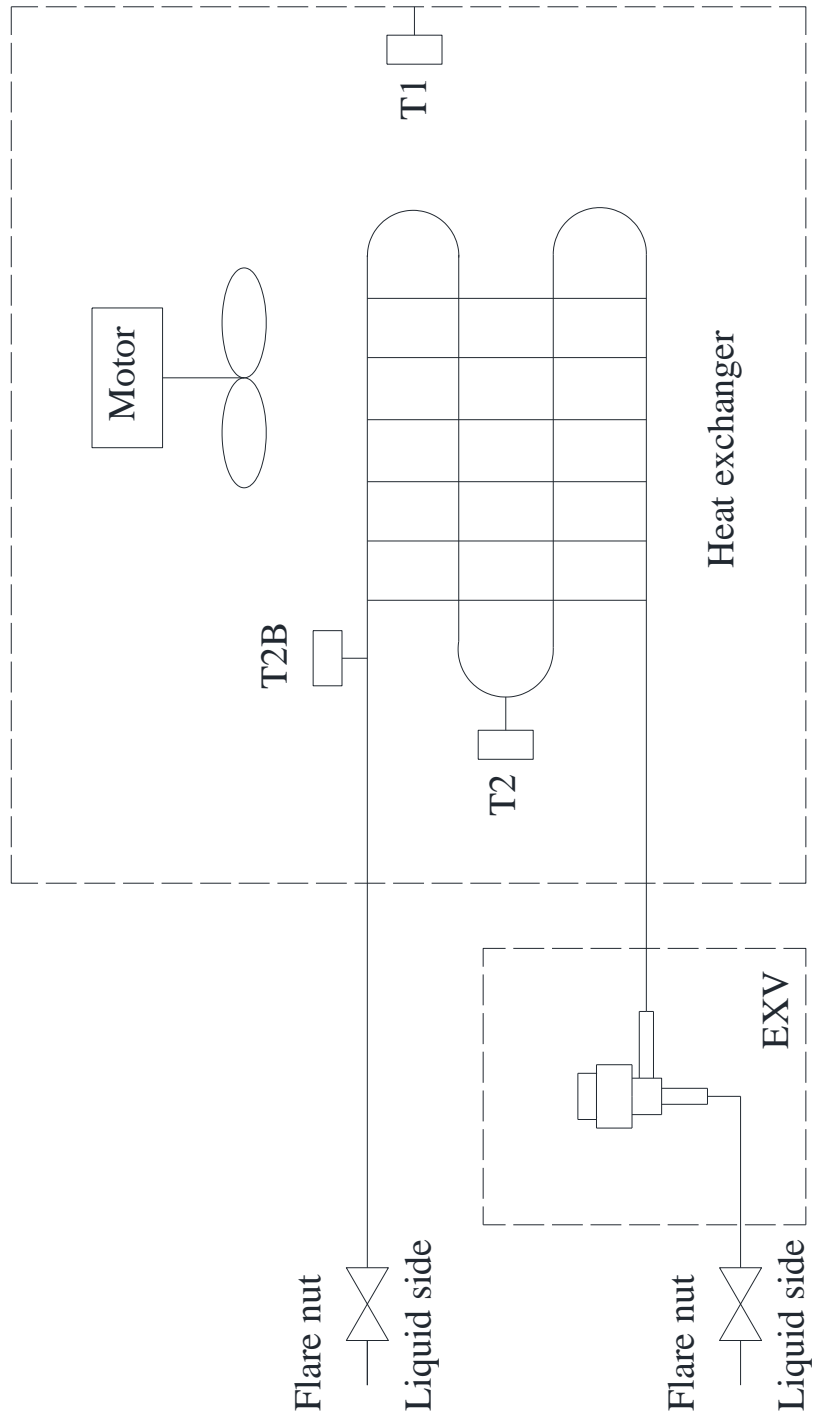

Notes:

- 1) T1: Room temperature sensor
- 2) T2: Temperature sensor of middle heat exchanger
- 3) T2B: Temperature sensor of heat exchanger outlet
- 4) EXV: Electrical expansion valve

5. Wiring diagram

5.1 Wiring diagram

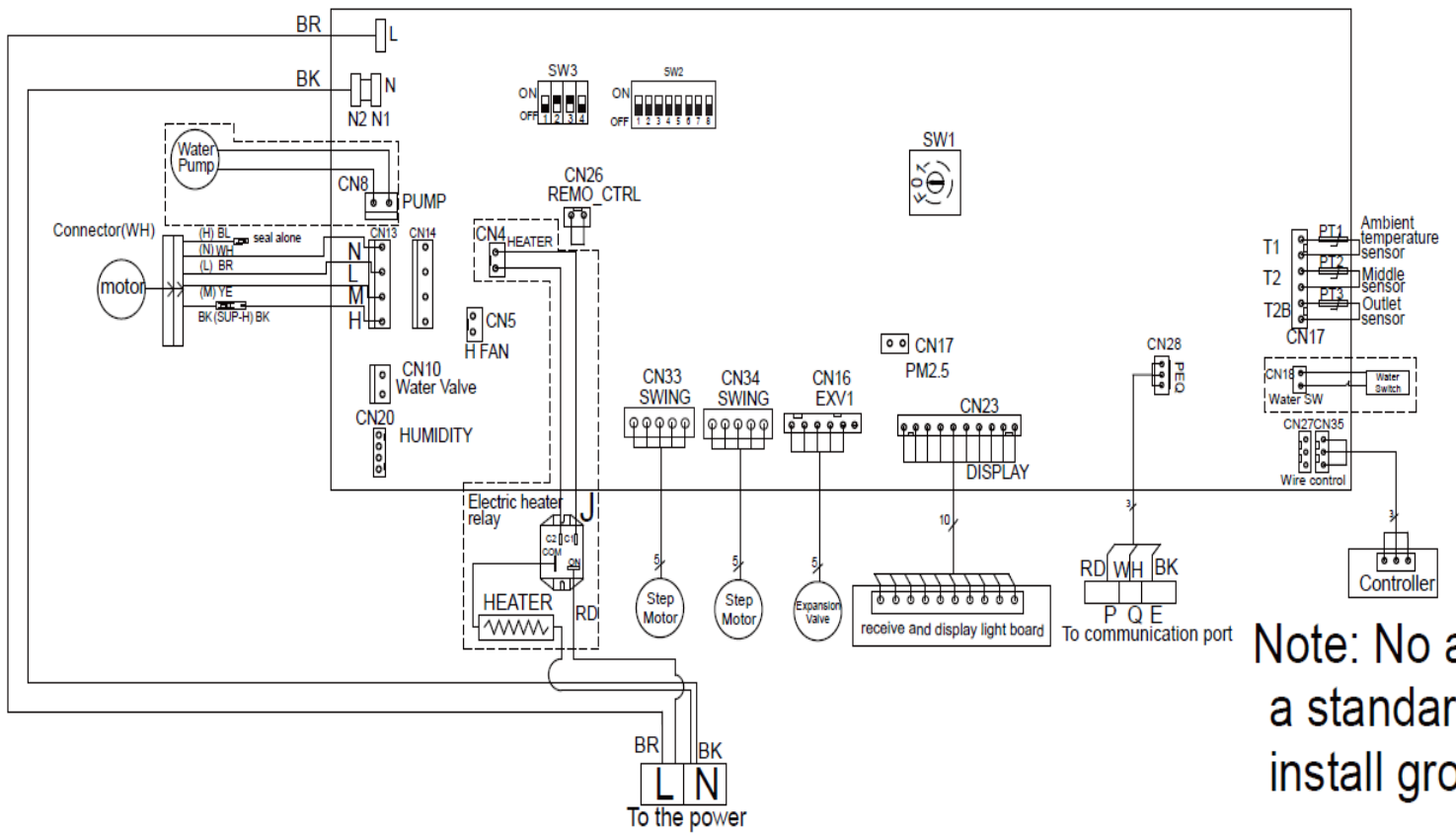

Notes:

1) Color code:

- RD: Red
- OR: Orange
- BK: Black:
- BR: Brown
- WH: White

2) T1: Room temperature sensor

3) T2: Temperature sensor of middle heat exchanger

4) T2B: Temperature sensor of heat exchanger outlet

5) EXV: Electrical expansion valve

5.2 Dial switches

5.2.1 SW1: Capacity

switch Different number in the switch indicates different capacity. It is set in factory; leave it as default setting,





HP	0.8	1	1.2	1.7	2	2.5	3	3.2	4	5	6
Power	18/22	25/26/28	32/35/36	40/45/46	50/51/56	60/63/66/71	80	88/90	100/110/112	120/125/140	150/160
Dial code	0	1	2	3	4	5	6	7	8	9	A



Remarks:







1. Fan motor's factory default setting is super high speed, the connection wire is black to black.
2. If unit have 2 motors, then both motors factory default settings are super high speed.
3. Relay and relative connection wires of electrical heater need installing only for the units with electrical heater.
4. on-site installation can be selected according to the length of the return air box and noise changed to high windshield.

5.2.2 SW3

Note:

	That DIP to ON
	That DIP to Digital

Factory default	
SW3	SW2
	





Type selection	
SW3 NO.1,2,3	Type
	Normal duct unit
	Fresh air processor
	One-way cassette
	Two-way cassette
	HRV
	10HP floor standing unit
	Reserve

Mode Select bits	
SW3 NO.4	Automatic Addressing mode and (Factory default)
SW3 NO.5	Test mode (to allow clear address)

5.2.3 SW2

Refrigeration temperature compensation temperature value select bits	
SW2 NO.1	3 °C Factory default
SW2 NO.2	1 °C

Heating temperature compensation temperature value select bits	
SW2 NO.3	6 °C Factory default
SW2 NO.4	2 °C

Anti-cold wind off the fan temperature selection bit	
SW2 NO.3&4	Temperature selection
	Factory default 15 °C
	20 °C
	24 °C
	26 °C

Heating stop the fan time to chooset	
SW2 NO.5	4min Factory default
SW2 NO.6	8min

6 Capacity tables

6.1 Cooling

TC: Total Capacity SC: Sensible Capacity WB: Wet-bulb Temperature DB: Dry-bulb Temperature

Capacity (kW)	Outdoor temperature (°C DB)	Indoor temperature (°C WB/DB)													
		14/20		16/23		18/26		19/27		20/28		22/30		24/32	
		TH	SH	TH	SH	TH	SH	TH	SH	TH	SH	TH	SH	TH	SH
		kW	kW	kW	kW	kW	kW	kW	kW	kW	kW	kW	kW	kW	kW
4.5	10.0	3.2	2.6	3.8	2.8	4.2	3.1	4.5	3.2	4.9	3.2	5.4	3.7	6.0	3.3
	12.0	3.2	2.6	3.8	2.8	4.2	3.1	4.5	3.2	4.9	3.2	5.4	3.7	6.0	3.3
	14.0	3.2	2.6	3.8	2.8	4.2	3.1	4.5	3.2	4.9	3.2	5.4	3.7	5.9	3.3
	16.0	3.2	2.6	3.8	2.8	4.2	3.1	4.5	3.2	4.9	3.2	5.4	3.7	5.7	3.2
	18.0	3.2	2.6	3.8	2.8	4.2	3.1	4.5	3.2	4.9	3.2	5.4	3.7	5.8	3.3
	20.0	3.2	2.6	3.8	2.8	4.2	3.1	4.5	3.2	4.9	3.2	5.4	3.7	5.8	3.3
	21.0	3.2	2.6	3.8	2.8	4.2	3.1	4.5	3.2	4.9	3.2	5.4	3.7	5.7	3.3
	23.0	3.2	2.6	3.8	2.8	4.2	3.1	4.5	3.2	4.9	3.2	5.4	3.7	5.6	3.2
	25.0	3.2	2.6	3.8	2.8	4.2	3.1	4.5	3.2	4.9	3.2	5.3	3.3	5.5	3.2
	27.0	3.2	2.6	3.8	2.8	4.2	3.1	4.5	3.2	4.9	3.2	5.2	3.2	5.3	3.0
	29.0	3.2	2.6	3.8	2.8	4.2	3.1	4.5	3.2	4.9	3.2	5.2	3.2	5.3	3.0
	31.0	3.2	2.6	3.8	2.8	4.2	3.1	4.5	3.2	4.9	3.2	5.1	3.1	5.2	2.9
	33.0	3.2	2.6	3.8	2.8	4.2	3.1	4.5	3.2	4.9	3.2	5.0	3.1	5.2	2.9
	35.0	3.2	2.6	3.8	2.8	4.2	3.1	4.5	3.2	4.9	3.2	4.9	3.0	5.1	2.9
	37.0	3.2	2.6	3.8	2.8	4.2	3.1	4.5	3.2	4.9	3.2	4.9	3.1	5.0	2.8
39.0	3.2	2.6	3.8	2.8	4.2	3.1	4.5	3.2	4.7	3.1	4.8	3.1	4.9	2.8	
5.6	10	3.88	3.50	4.58	3.65	5.28	4.11	5.60	4.11	6.10	4.38	6.53	4.44	6.79	3.98
	12	3.88	3.50	4.58	3.65	5.28	4.11	5.60	4.11	6.10	4.38	6.53	4.44	6.73	3.95
	14	3.88	3.50	4.58	3.65	5.28	4.11	5.60	4.11	6.10	4.38	6.47	4.40	6.67	3.91
	16	3.88	3.50	4.58	3.65	5.28	4.11	5.60	4.11	6.10	4.38	6.41	4.36	6.61	3.88
	18	3.88	3.50	4.58	3.65	5.28	4.11	5.60	4.11	6.10	4.38	6.35	4.32	6.55	3.84
	19	3.88	3.50	4.58	3.65	5.28	4.11	5.60	4.11	6.10	4.38	6.29	4.28	6.49	3.80
	21	3.88	3.50	4.58	3.65	5.28	4.11	5.60	4.11	6.10	4.38	6.24	4.24	6.42	3.77
	23	3.88	3.50	4.58	3.65	5.28	4.11	5.60	4.11	6.10	4.38	6.18	4.20	6.36	3.73
	25	3.88	3.50	4.58	3.65	5.28	4.11	5.60	4.11	6.10	4.33	6.12	4.16	6.30	3.70
	27	3.88	3.50	4.58	3.65	5.28	4.11	5.60	4.11	6.04	4.29	6.06	4.12	6.24	3.66
	29	3.88	3.50	4.58	3.65	5.28	4.11	5.60	4.11	5.98	4.25	6.00	4.08	6.18	3.63
	31	3.88	3.50	4.58	3.65	5.28	4.11	5.60	4.11	5.93	4.21	5.94	4.04	6.12	3.59
	33	3.88	3.50	4.58	3.65	5.28	4.11	5.60	4.11	5.87	4.13	5.88	4.00	6.06	3.56
	35	3.88	3.50	4.58	3.65	5.28	4.11	5.60	4.11	5.78	4.09	5.83	3.96	6.00	3.52
	37	3.88	3.50	4.58	3.65	5.28	4.11	5.60	4.09	5.70	4.01	5.77	3.88	5.88	3.45
39	3.88	3.50	4.58	3.65	5.28	4.11	5.60	4.07	5.66	3.97	5.71	3.84	5.82	3.42	

Capacity (kW)	Outdoor temperature (°C DB)	Indoor temperature (°C WB/DB)													
		14/20		16/23		18/26		19/27		20/28		22/30		24/32	
		TH	SH	TH	SH	TH	SH	TH	SH	TH	SH	TH	SH	TH	SH
		kW	kW	kW	kW	kW	kW	kW	kW	kW	kW	kW	kW	kW	kW
7.1	10.0	10	4.92	4.44	5.80	4.63	6.69	5.21	7.10	5.21	7.73	5.55	8.27	5.63	8.60
	12.0	12	4.92	4.44	5.80	4.63	6.69	5.21	7.10	5.21	7.73	5.55	8.27	5.63	8.53
	14.0	14	4.92	4.44	5.80	4.63	6.69	5.21	7.10	5.21	7.73	5.55	8.20	5.58	8.45
	16.0	16	4.92	4.44	5.80	4.63	6.69	5.21	7.10	5.21	7.73	5.55	8.13	5.53	8.38
	18.0	18	4.92	4.44	5.80	4.63	6.69	5.21	7.10	5.21	7.73	5.55	8.05	5.47	8.30
	20.0	19	4.92	4.44	5.80	4.63	6.69	5.21	7.10	5.21	7.73	5.55	7.98	5.42	8.22
	21.0	21	4.92	4.44	5.80	4.63	6.69	5.21	7.10	5.21	7.73	5.55	7.91	5.37	8.15
	23.0	23	4.92	4.44	5.80	4.63	6.69	5.21	7.10	5.21	7.73	5.55	7.83	5.32	8.07
	25.0	25	4.92	4.44	5.80	4.63	6.69	5.21	7.10	5.21	7.73	5.50	7.76	5.27	7.99
	27.0	27	4.92	4.44	5.80	4.63	6.69	5.21	7.10	5.21	7.66	5.44	7.68	5.22	7.92
	29.0	29	4.92	4.44	5.80	4.63	6.69	5.21	7.10	5.21	7.58	5.39	7.61	5.17	7.84
	31.0	31	4.92	4.44	5.80	4.63	6.69	5.21	7.10	5.21	7.51	5.34	7.54	5.12	7.76
	33.0	33	4.92	4.44	5.80	4.63	6.69	5.21	7.10	5.21	7.44	5.24	7.46	5.07	7.69
	35.0	35	4.92	4.44	5.80	4.63	6.69	5.21	7.10	5.21	7.33	5.18	7.39	5.02	7.61
	37.0	37	4.92	4.44	5.80	4.63	6.69	5.21	7.10	5.19	7.22	5.08	7.31	4.92	7.46
39.0	39	4.92	4.44	5.80	4.63	6.69	5.21	7.10	5.15	7.17	5.03	7.24	4.87	7.38	
8.0	10.0	5.54	5.00	6.54	5.22	7.54	5.88	8.00	5.87	8.71	6.25	9.32	6.34	9.70	5.69
	12.0	5.54	5.00	6.54	5.22	7.54	5.88	8.00	5.87	8.71	6.25	9.32	6.34	9.61	5.64
	14.0	5.54	5.00	6.54	5.22	7.54	5.88	8.00	5.87	8.71	6.25	9.24	6.28	9.52	5.59
	16.0	5.54	5.00	6.54	5.22	7.54	5.88	8.00	5.87	8.71	6.25	9.16	6.23	9.44	5.54
	18.0	5.54	5.00	6.54	5.22	7.54	5.88	8.00	5.87	8.71	6.25	9.07	6.17	9.35	5.49
	20.0	5.54	5.00	6.54	5.22	7.54	5.88	8.00	5.87	8.71	6.25	8.99	6.11	9.27	5.44
	21.0	5.54	5.00	6.54	5.22	7.54	5.88	8.00	5.87	8.71	6.25	8.91	6.06	9.18	5.38
	23.0	5.54	5.00	6.54	5.22	7.54	5.88	8.00	5.87	8.71	6.25	8.82	6.00	9.09	5.33
	25.0	5.54	5.00	6.54	5.22	7.54	5.88	8.00	5.87	8.71	6.19	8.74	5.94	9.01	5.28
	27.0	5.54	5.00	6.54	5.22	7.54	5.88	8.00	5.87	8.63	6.13	8.66	5.89	8.92	5.23
	29.0	5.54	5.00	6.54	5.22	7.54	5.88	8.00	5.87	8.55	6.08	8.57	5.83	8.83	5.18
	31.0	5.54	5.00	6.54	5.22	7.54	5.88	8.00	5.87	8.47	6.02	8.49	5.77	8.75	5.13
	33.0	5.54	5.00	6.54	5.22	7.54	5.88	8.00	5.87	8.38	5.90	8.41	5.72	8.66	5.08
	35.0	5.54	5.00	6.54	5.22	7.54	5.88	8.00	5.87	8.26	5.84	8.32	5.66	8.58	5.03
	37.0	5.54	5.00	6.54	5.22	7.54	5.88	8.00	5.84	8.14	5.73	8.24	5.55	8.41	4.93
39.0	5.54	5.00	6.54	5.22	7.54	5.88	8.00	5.81	8.08	5.67	8.16	5.49	8.32	4.88	

6.2 Heating

TC: Total Capacity WB: Wet-bulb Temperature DB: Dry-bulb Temperature

Capacity (kW)	Outdoor temperature (°C DB)		Indoor temperature (°C WB/DB)					
			16	18	20	21	22	24
	WB	DB	TH	TH	TH	TH	TH	TH
4.5	-15	-14.7	3.25	3.25	3.25	3.25	3.25	3.25
	-13	-12.6	3.35	3.35	3.35	3.35	3.35	3.35
	-11	-10.5	3.50	3.50	3.50	3.50	3.50	3.50
	-10	-9.5	3.65	3.65	3.65	3.65	3.65	3.65
	-9.1	-8.5	3.75	3.75	3.75	3.75	3.75	3.75
	-7.6	-7	3.80	3.80	3.80	3.80	3.80	3.80
	-5.6	-5	3.95	3.95	3.95	3.95	3.95	3.95
	-3.7	-3	4.15	4.15	4.15	4.15	4.15	4.15
	-0.7	0	4.45	4.45	4.45	4.45	4.45	4.20
	2.2	3	4.70	4.70	4.70	4.70	4.60	4.20
	4.1	5	4.85	4.85	4.85	4.85	4.60	4.20
	6	7	5.00	5.00	5.00	4.85	4.60	4.20
	7.9	9	5.15	5.15	5.00	4.85	4.60	4.20
	9.8	11	5.30	5.30	5.00	4.85	4.60	4.20
	11.8	13	5.50	5.40	5.00	4.85	4.60	4.20
13.7	15	5.65	5.40	5.00	4.85	4.60	4.20	
5.6	-15	-14.7	4.10	4.10	4.10	4.10	4.10	4.10
	-13	-12.6	4.22	4.22	4.22	4.22	4.22	4.22
	-11	-10.5	4.41	4.41	4.41	4.41	4.41	4.41
	-10	-9.5	4.60	4.60	4.60	4.60	4.60	4.60
	-9.1	-8.5	4.73	4.73	4.73	4.73	4.73	4.73
	-7.6	-7	4.79	4.79	4.79	4.79	4.79	4.79
	-5.6	-5	4.98	4.98	4.98	4.98	4.98	4.98
	-3.7	-3	5.23	5.23	5.23	5.23	5.23	5.23
	-0.7	0	5.61	5.61	5.61	5.61	5.61	5.29
	2.2	3	5.92	5.92	5.92	5.92	5.80	5.29
	4.1	5	6.11	6.11	6.11	6.11	5.80	5.29
	6	7	6.30	6.30	6.30	6.11	5.80	5.29
	7.9	9	6.49	6.49	6.30	6.11	5.80	5.29
	9.8	11	6.68	6.68	6.30	6.11	5.80	5.29
	11.8	13	6.93	6.80	6.30	6.11	5.80	5.29
13.7	15	7.12	6.80	6.30	6.11	5.80	5.29	

Capacity (kW)	Outdoor temperature (°C DB)		Indoor temperature (°C WB/DB)					
			16	18	20	21	22	24
			TH	TH	TH	TH	TH	TH
	WB	DB	kW	kW	kW	kW	kW	kW
7.1	-15	-14.7	5.20	5.20	5.20	5.20	5.20	5.20
	-13	-12.6	5.36	5.36	5.36	5.36	5.36	5.36
	-11	-10.5	5.60	5.60	5.60	5.60	5.60	5.60
	-10	-9.5	5.84	5.84	5.84	5.84	5.84	5.84
	-9.1	-8.5	6.00	6.00	6.00	6.00	6.00	6.00
	-7.6	-7	6.08	6.08	6.08	6.08	6.08	6.08
	-5.6	-5	6.32	6.32	6.32	6.32	6.32	6.32
	-3.7	-3	6.64	6.64	6.64	6.64	6.64	6.64
	-0.7	0	7.12	7.12	7.12	7.12	7.12	6.72
	2.2	3	7.52	7.52	7.52	7.52	7.36	6.72
	4.1	5	7.76	7.76	7.76	7.76	7.36	6.72
	6	7	8.00	8.00	8.00	7.76	7.36	6.72
	7.9	9	8.24	8.24	8.00	7.76	7.36	6.72
	9.8	11	8.48	8.48	8.00	7.76	7.36	6.72
	11.8	13	8.80	8.64	8.00	7.76	7.36	6.72
	13.7	15	9.04	8.64	8.00	7.76	7.36	6.72
8	-15	-14.7	5.85	5.85	5.85	5.85	5.85	5.85
	-13	-12.6	6.03	6.03	6.03	6.03	6.03	6.03
	-11	-10.5	6.30	6.30	6.30	6.30	6.30	6.30
	-10	-9.5	6.57	6.57	6.57	6.57	6.57	6.57
	-9.1	-8.5	6.75	6.75	6.75	6.75	6.75	6.75
	-7.6	-7	6.84	6.84	6.84	6.84	6.84	6.84
	-5.6	-5	7.11	7.11	7.11	7.11	7.11	7.11
	-3.7	-3	7.47	7.47	7.47	7.47	7.47	7.47
	-0.7	0	8.01	8.01	8.01	8.01	8.01	7.56
	2.2	3	8.46	8.46	8.46	8.46	8.28	7.56
	4.1	5	8.73	8.73	8.73	8.67	8.28	7.56
	6	7	9.00	9.00	8.80	8.67	8.28	7.56
	7.9	9	9.27	9.27	9.00	8.67	8.28	7.56
	9.8	11	9.54	9.54	9.00	8.67	8.28	7.56
	11.8	13	9.90	9.72	9.00	8.67	8.28	7.56
	13.7	15	10.17	9.72	9.00	8.67	8.28	7.56

7 Electrical characteristics

Model	Indoor unit				MFC	Power cable			Signal cable
	Hz	Voltage	Minimum	Maximum		L ≤ 20m	L ≤ 50m	Grounded	
VECT015Q3A-GWV045	50Hz	220-240V	198	264	15	2*2.5mm ²	2*4.0mm ²	2.5mm ²	2*0.75 mm ²
VECT019Q3A-GWV056	50Hz	220-240V	198	264	15	2*2.5mm ²	2*4.0mm ²	2.5mm ²	2*0.75 mm ²
VECT024Q3A-GWV071	50Hz	220-240V	198	264	15	2*2.5mm ²	2*4.0mm ²	2.5mm ²	2*0.75 mm ²
VECT027Q3A-GWV080	50Hz	220-240V	198	264	15	2*2.5mm ²	2*4.0mm ²	2.5mm ²	2*0.75 mm ²

Notes:

- 1) *Minimum: Permitted minimum operating voltage, lower than this value may damage the system*
- 2) *Maximum: Permitted maximum operating voltage, higher than this value may damage the system*
- 3) *MC: Minimum Current (A)*
- 4) *MFC: Maximum Fuse Current (A)*
- 5) *L: Total length of cable (m)*

9 Sound levels

9.1 Test condition

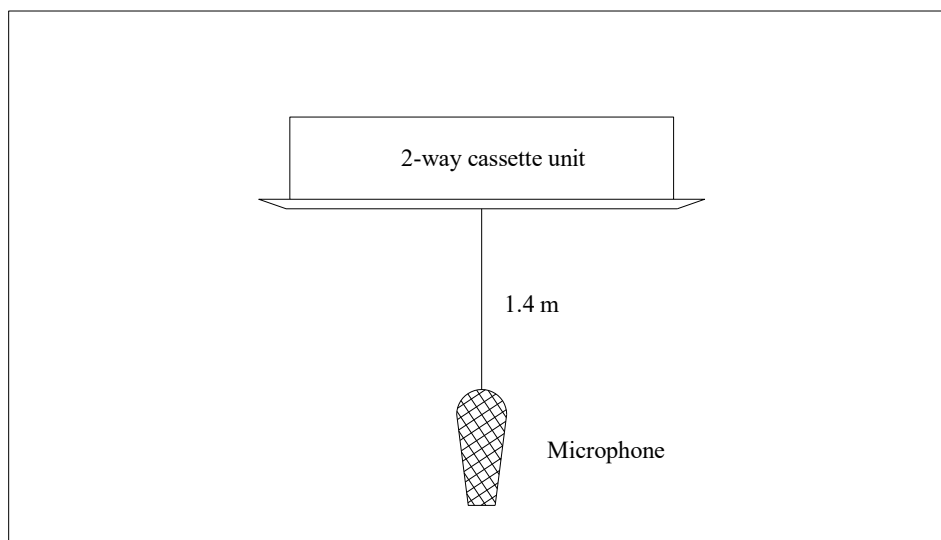









Notes:

Semi-anechoic chamber conversion value, measured at a point 1m in front of the unit at a height of 1.4m

8 Accessories

8.1 Standard accessories.

Name of accessories	Numbers	Shape	Application
Installation instruction for indoor unit	1	The manual	(Please be sure to hand it to user.)
Insulating tube	2		To encase single joints of high and low pressure pipes.
Large-sized heat insulating mattress	1		Heat insulation
Ribbon	10		Bind up cables and connecting pipes.
Dome insulated tip	6		Used to connect wires
X-type insulated tip	3		Used to connect wires
Remote controller	1		Control A/C
Battery	2		Supply power to remote controller
Blank valve bag	4		Used to contain accessories.

10.2 Local buy accessories.

Cooper pipe	Type	4.5kW~5.6kW	7.1kW~8.0kW
	Liquid pipe (mm)	Φ 6.35×0.8	Φ 9.52×0.8
Gas pipe (mm)	Φ 12.7×0.8	Φ 15.88×1.0	
PVC drainpipe	For the indoor unit drainpipe. The length is decided according to the actual need.		
Insulation bushing	Assort inner diameter respectively with relevant copper pipe and hard polyethylene plastic pipe. The thickness is usually 10 mm (above). It should be appropriately thickened in closed and wet areas.		

9 Exploded view

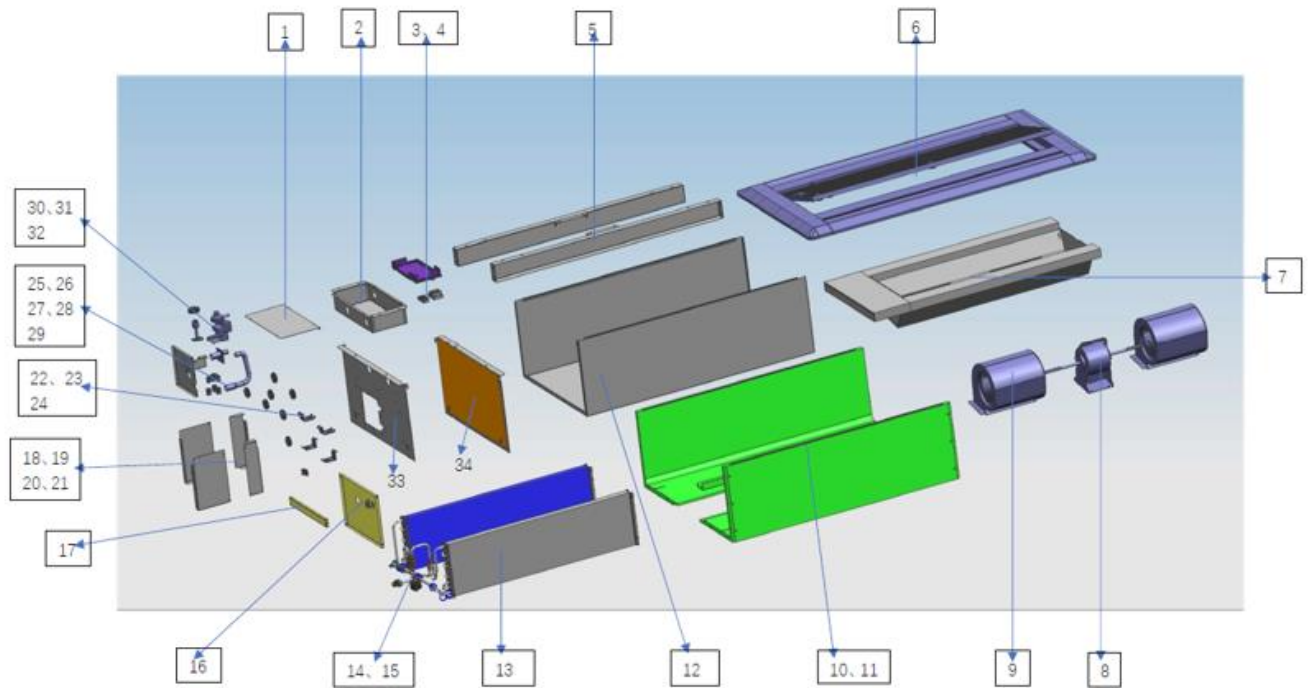

No.	Part Name	Quantity
1	Electric control box cover	1
2	Electric control box	1
3	Indoor main control board	1
4	terminal block	1+1
5	Water connection support board	2
6	Panel	1
7	Water connection	1
8	Motor	1
9	Wind wheel volute	2
10	Chassis foam 1	1
11	Chassis foam 2	1
12	Chassis	1
13	Evaporator	2
14	Evaporator output tube component	1
15	Evaporator input tube component	1
16	Evaporator connecting board	1
17	Evaporator connecting board 2	1
18	Evapoor fixing board 1(left side)	1
19	Evapoor fixing board 2(left side)	1
20	Evapoor fixing board 1(right side)	1
21	Evapoor fixing board 2(right side)	1
22	hook	4
23	Rubber ring	2
24	Screw	/
25	Drainage pipe	1
26	Drainage	1
27	Water pump bracket component	1
28	Cushion	3
29	Tight band	2
30	Pump installation seat	1
31	Water level switch	1
32	Pump component	1
33	(RoHS) Rear cover foam	1
34	(RoHS) Front wall panel pasting components	1



OMEGA
ENVIRONMENTAL
TECHNOLOGIES LLC.

17702 Mitchell North, #101
Irvine, CA. 92614 .USA
Tel: 714 795 2830
Fax: 714 966 1646
info@omegavrf.com
www.omegavrf.com

OTECTM
AIR CONDITIONING

Showroom & Technology Center
11380 Interchange Circle North
Miramar, FL 33025 .USA
Tel: 305 901 1270
Fax: 954 212 8280
info@otecomega.com
www.otecomega.com

VECTQ0A-TM1G0123