

# VEWM Series

## High Wall Indoor Unit

### Technical Manual

**220~240V/1/50-60Hz**

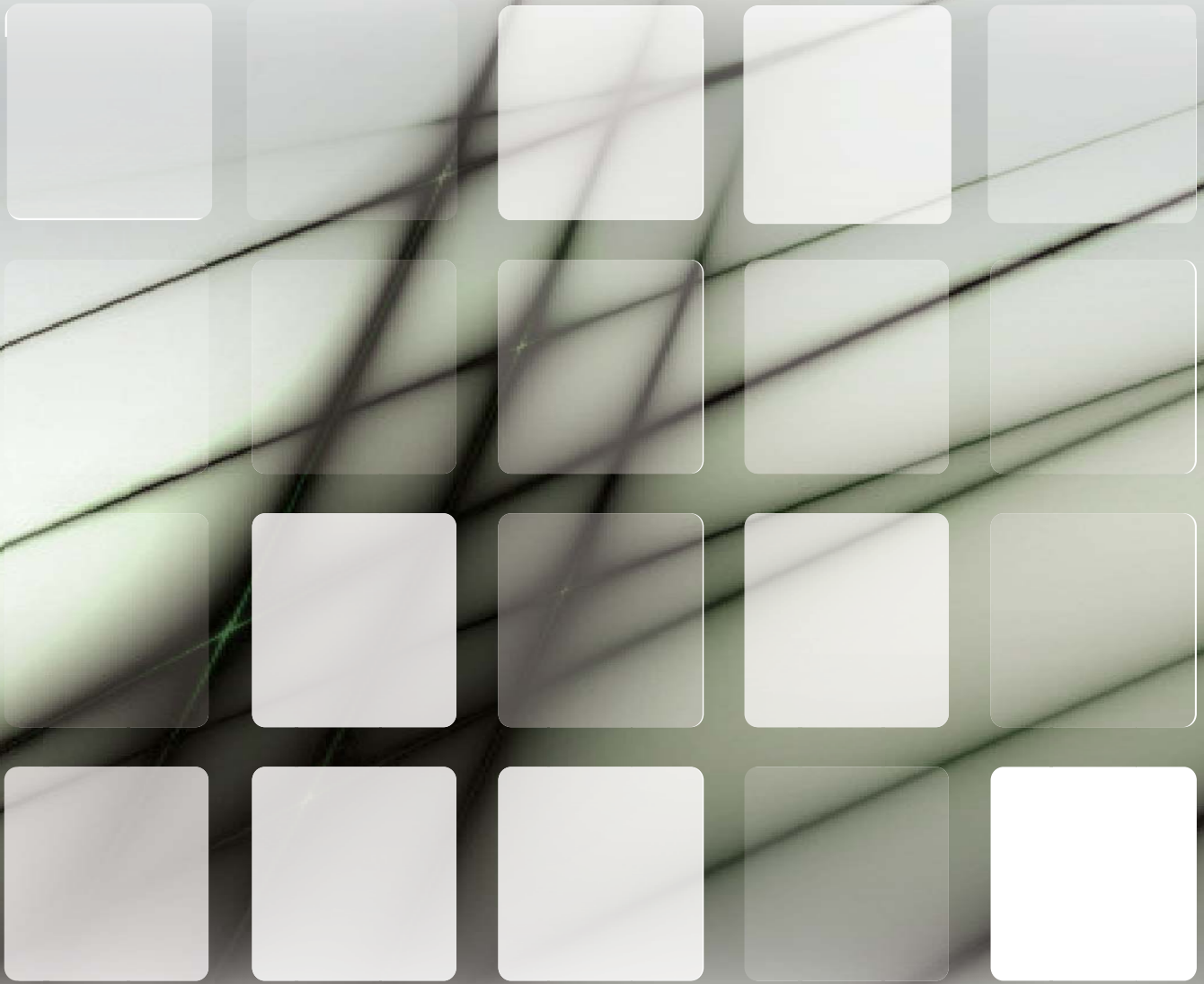

# Wall Mounted

<b>1 Specifications .....</b>	<b>4</b>
<b>2 Dimensions.....</b>	<b>7</b>
<b>3 Unit Placement.....</b>	<b>8</b>
<b>4 Piping Diagram .....</b>	<b>9</b>
<b>5 Wiring Diagram .....</b>	<b>10</b>
<b>6 Capacity Tables.....</b>	<b>11</b>
<b>7 Electrical Characteristics .....</b>	<b>12</b>
<b>8 Sound Levels .....</b>	<b>13</b>
<b>9 Temperature and Airflow Distributions .....</b>	<b>15</b>

# OMEGA Indoor Units

## 1 Specifications

### VEWM006T0A-DWV015, VEWM008T0A-DWV022, VEWM010T0A-DWV028

Model			VEWM006T0A-DWV015	VEWM008T0A-DWV022	VEWM010T0A-DWV028
Power supply			1 phase, 220-240V, 50/60Hz		
Cooling <sup>1</sup>	Capacity	kW	1.5	2.2	2.8
		kBtu/h	5.1	7.5	9.6
	Power input	W	18	21	24
Heating <sup>2</sup>	Capacity	kW	1.7	2.4	3.2
		kBtu/h	5.8	8.2	10.9
	Power input	W	18	21	24
Fan motor	Model		ZKSN-20-8-5L	ZKSN-20-8-5L	ZKSN-20-8-5L
	Type		DC		
Indoor coil	Number of rows		1	1	2&3
	Fin spacing	mm	1.3	1.3	1.33
	Fin type		Hydrophilic aluminum		
	Tube OD and type	mm	Φ7 Inner-groove		Φ5 Inner-groove
	Dimensions (L×H×W)	mm	530×170×95	530×170×95	530×170×95
	Number of circuits		2	2	6
Air flow rate <sup>3</sup>		m <sup>3</sup> /h	460/440/420/400 /380/360/340	500/470/440/410 /390/370/340	540/510/470/430 /400/370/340
Sound pressure level <sup>4</sup>		dB(A)	32/31/30/30/29/28 /27	33/32/31/30/29/28 /27	35/34/33/32/31/30 /28
Sound power level		dB(A)	45/44/43/43/42/41 /40	46/45/44/43/42/41 /40	50/49/48/47/46/44 /42
Unit	Net dimensions <sup>5</sup> (W×H×D)		29 1/2x 11 5/8x 10 1/2 (750×295×265)		
	Packed dimensions (W×H×D)		34 1/2x 15 1/8x 14 1/8 (875×385×360)		
	Net/Gross weight		kg	19.84(9)/25.35(11.5)	19.84(9)/25.35(11.5)
Refrigerant type			R410A/R32		
Throttle		Type	Electronic expansion valve		
Design pressure (H/L)		MPa	4.4/2.6		
Pipe connections	Liquid/Gas pipe		Φ6.35/Φ12.7		
	Drain pipe		OD Φ16		

#### Notes:

- Indoor temperature 27°C DB, 19°C WB; outdoor temperature 35°C DB; equivalent refrigerant piping length 7.5m with zero level difference.
- Indoor temperature 20°C DB; outdoor temperature 7°C DB, 6°C WB; equivalent refrigerant piping length 7.5m with zero level difference.
- Fan motor speed and air flow rate are from the highest speed to the lowest speed, total 7 rates for each model.
- Sound pressure level is from highest level to lowest level, total 7 levels for each model. Sound pressure level is measured in an anechoic chamber.
- The dimension is only the body size, excluding the size of the installation lug, connecting copper pipe, etc. For detailed dimensions, please refer to the installation manual.

## VEWM012T0A-DWV036, VEWM015T0A-DWV045, VEWM019T0A-DWV056

Model			VEWM012T0A-DWV036	VEWM015T0A-DWV045	VEWM019T0A-DWV056
Power supply			1 phase, 220-240V, 50/60Hz		
Cooling <sup>1</sup>	Capacity	kW	3.6	4.5	5.6
		kBtu/h	12.3	15.4	19.1
	Power input	W	27	30	40
Heating <sup>2</sup>	Capacity	kW	4.0	5.0	6.3
		kBtu/h	13.6	17.1	21.5
	Power input	W	27	30	40
Fan motor	Model		ZKSN-20-8-5L	ZKSN-20-8-5L	ZKSN-20-8-5L
	Type		DC		
Indoor coil	Number of rows		2&3		
	Fin spacing	mm	1.33		
	Fin type		Hydrophilic aluminum		
	Tube OD and type	mm	Φ5 Inner-groove		
	Dimensions (L×H×W)	mm	530×170×95	730×170×95	730×170×95
	Number of circuits		6	6	6
Air flow rate <sup>3</sup>	m <sup>3</sup> /h	580/540/500/460 /420/380/340	720/670/620/560 /510/460/410	860/780/700/620 /550/480/410	
Sound pressure level <sup>4</sup>	dB(A)	37/36/34/33/31/30 /28	37/35/33/32/31/30 /29	41/39/37/35/33/31 /29	
Sound power level	dB(A)	54/53/51/50/48/46 /44	54/52/50/49/48/46 /44	56/54/52/50/48/46 /44	
Unit	Net dimensions <sup>5</sup> (W×H×D)	in/mm	29 1/2x 11 5/8x 10 1/2 (750×295×265)	37 3/8x 11 5/8x 10 3/7 (950×295×265)	
	Packed dimensions (W×H×D)	in/mm	34 1/2x 15 1/8x 14 1/2 (875×385×360)	42 3/8x 15 1/8x 14 1/8 1/81075×385×360	
	Net/Gross weight	lbs/kg	22.05(10)/27.56(12.5)	25.35(11.5)/30.86(14)	
Refrigerant type			R410A/R32		
Throttle		Type	Electronic expansion valve		
Design pressure (H/L)		MPa	4.4/2.6		
Pipe connections	Liquid/Gas pipe	mm	Φ6.35/Φ12.7		
	Drain pipe	mm	OD Φ16		

**Notes:**

- Indoor temperature 27°C DB, 19°C WB; outdoor temperature 35°C DB; equivalent refrigerant piping length 7.5m with zero level difference.
- Indoor temperature 20°C DB; outdoor temperature 7°C DB, 6°C WB; equivalent refrigerant piping length 7.5m with zero level difference.
- Fan motor speed and air flow rate are from the highest speed to the lowest speed, total 7 rates for each model.
- Sound pressure level is from highest level to lowest level, total 7 levels for each model. Sound pressure level is measured in an anechoic chamber.
- The dimension is only the body size, excluding the size of the installation lug, connecting copper pipe, etc. For detailed dimensions, please refer to the installation manual.

# OMEGA Indoor Units

## VEWM024T0A-DWV071, VEWM027T0A-DWV080

Model			VEWM024T0A-DWV071	VEWM027T0A-DWV080
Power supply			1 phase, 220-240V, 50/60Hz	
Cooling <sup>1</sup>	Capacity	kW	7.1	8.0
		kBtu/h	24.2	27.3
	Power input	W	50	65
Heating <sup>2</sup>	Capacity	kW	8.0	9.0
		kBtu/h	27.3	30.7
	Power input	W	50	65
Fan motor	Model		ZKSN-50-8-17L	ZKSN-50-8-17L
	Type		DC	
Indoor coil	Number of rows		2&3	
	Fin spacing	mm	1.33	
	Fin type		Hydrophilic aluminum	
	Tube OD and type	mm	Φ5 Inner-groove	
	Dimensions (L×H×W)	mm	980×170×95	980×170×95
	Number of circuits		8	8
Air flow rate <sup>3</sup>		m <sup>3</sup> /h	1220/1120/1030/940/850/750 /660	1380/1260/1140/1020/900/780 /660
Sound pressure level <sup>4</sup>		dB(A)	44/42/40/38/36/34/32	45/43/41/39/37/35/32
Sound power level		dB(A)	58/56/54/52/50/48/46	60/57/55/53/50/48/46
Unit	Net dimensions <sup>5</sup> (W×H×D)		47 1/21x 11 5/8x 10 3/8 (1200×295×265)	
	Packed dimensions (W×H×D)		51 3/4x 15 1/8 14 1/8 (1315×385×360)	
	Net/Gross weight		33.07(15)/39.68(18)	
Refrigerant type			R410A/R32	
Throttle		Type	Electronic expansion valve	
Design pressure (H/L)		MPa	4.4/2.6	
Pipe connections	Liquid/Gas pipe		Φ9.52/Φ15.9	
	Drain pipe		OD Φ16	

### Notes:

- Indoor temperature 27°C DB, 19°C WB; outdoor temperature 35°C DB; equivalent refrigerant piping length 7.5m with zero level difference.
- Indoor temperature 20°C DB; outdoor temperature 7°C DB, 6°C WB; equivalent refrigerant piping length 7.5m with zero level difference.
- Fan motor speed and air flow rate are from the highest speed to the lowest speed, total 7 rates for each model.
- Sound pressure level is from highest level to lowest level, total 7 levels for each model. Sound pressure level is measured in an anechoic chamber.
- The dimension is only the body size, excluding the size of the installation lug, connecting copper pipe, etc. For detailed dimensions, please refer to the installation manual.

## 2 Dimensions

### 2.1 Unit Dimensions

Figure 2.1: VEWM006(008,010,012,015,019,24,27) Wall mounted dimensions (unit: mm)

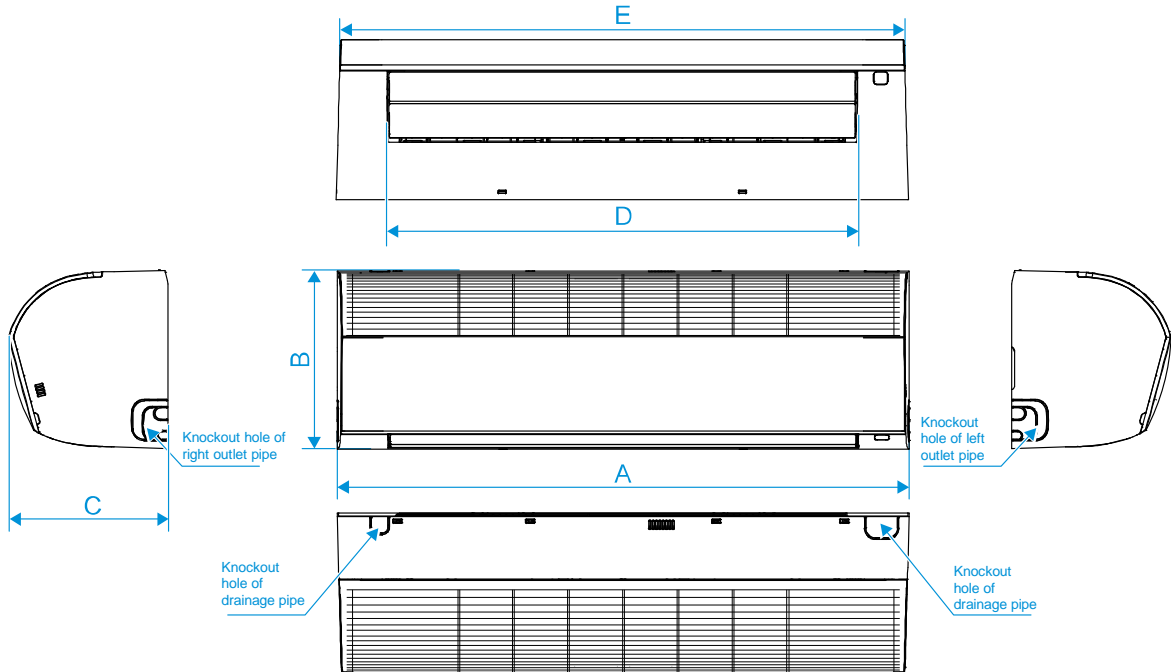

Capacity(kW)	A	B	C	D	E
VEWM006(008,010,012)TOA	750	295	265	581	736
VEWM015TOA-DWV045	950	295	265	781	936
VEWM019(024,027)TOA	1200	295	265	1025	1186

# OMEGA Indoor Units

## 3 Unit Placement

### 3.1 Placement Considerations

Unit placement should take account of the following considerations:

- Units should not be installed in the following locations:
  - A place filled with mineral oil, fumes or mist, like a kitchen.
  - A place where there are corrosive gases, such as acid or alkaline gases..
  - A place exposed to combustible gases and using volatile combustible gases such as diluent or gasoline.
  - A place where there is equipment emitting electromagnetic radiation.
  - A place where there is a high salt content in the air like a coast.
  - Do not use the air conditioner in an environment where an explosion may occur.
  - Places like in vehicles or cabin rooms.
  - Factories with major voltage fluctuations in the power supplies.
  - Other special environmental conditions.
- Units should be installed in positions where:
  - Ensure that the airflow in and out of the IDU is reasonably organized to form an air circulation in the room.
  - Ensure IDU maintenance space.
  - The nearer the drainage pipe and copper pipe are to the ODU, the lower the pipe cost is.
  - Prevent the air conditioner from blowing directly to the human body.
  - The closer the wiring to the power cabinet, the lower the wiring cost is.
  - Keep the air-conditioning return air away from the setting sun of the room.
  - Be careful not to interfere with the light tank, fire pipe, gas pipe and other facilities.
  - The IDU should not be lifted in the places like load-bearing beam and columns that affect the structural safety of the house.
  - The wired controller and the IDU should be in the same installation space; otherwise, the sampling point setting of the wired controller need to be changed.

### 3.2 Space Requirements

Figure 3.1: VEWM006(008,010,012,015,019) Wall mounted space requirements (unit: mm)

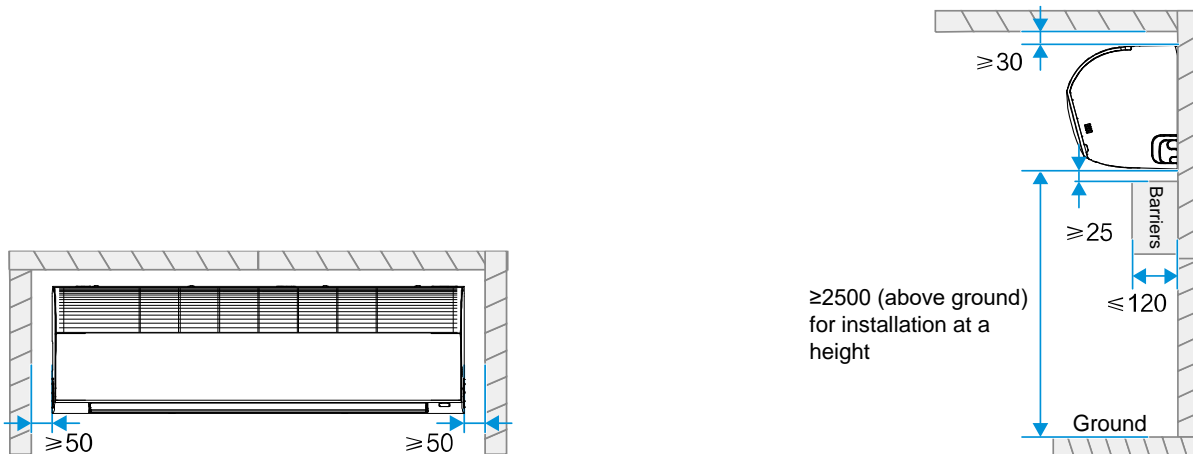

Positioning of mounting plate:

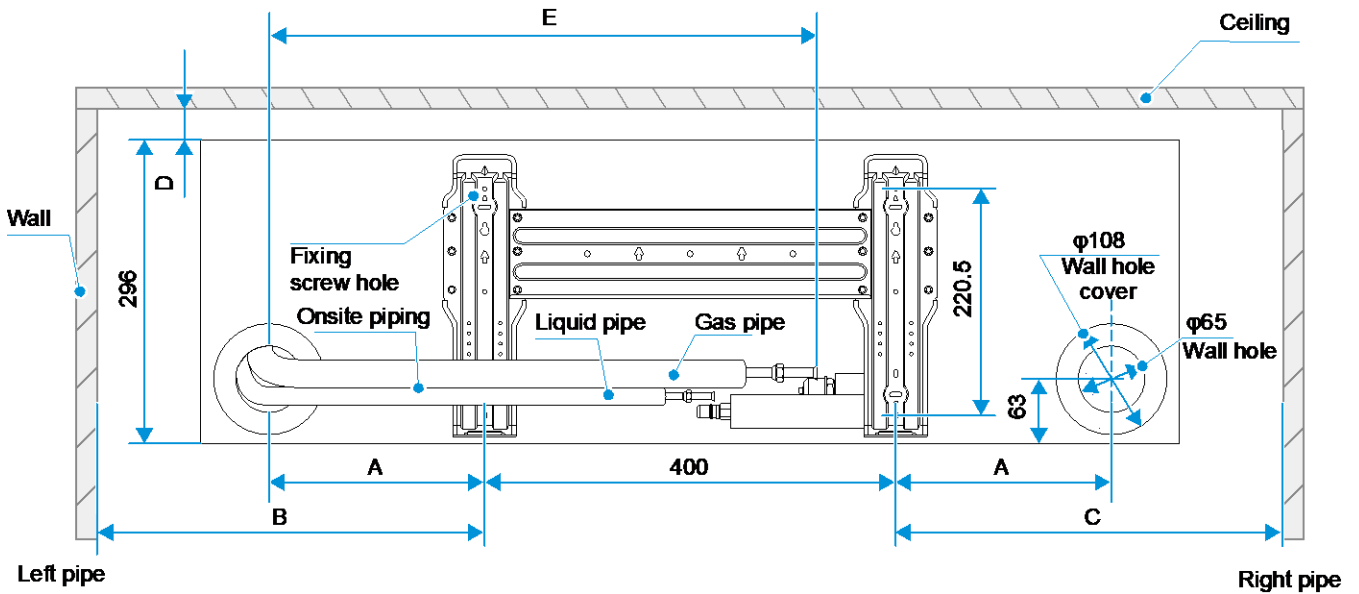

Capacity (kW)	Distance(mm)					Reserved lengths for power and signal cables	
	A	B	C	D	E	Left out pipe	Right out pipe
VEWM006(008,010,012)T0A	100	≥225	≥225	≥30	230	≥1115	≥415
VEWM015T0A-DWV045	180	≥325	≥325	≥30	412	≥1315	≥415
VEWM019(024,027)T0A	220	≥375	≥375	≥30	400	≥1565	≥415

## 4 Piping Diagram

Figure 4.1: VEWM006(008,010,012,015,019,24,27) Wall mounted piping diagram

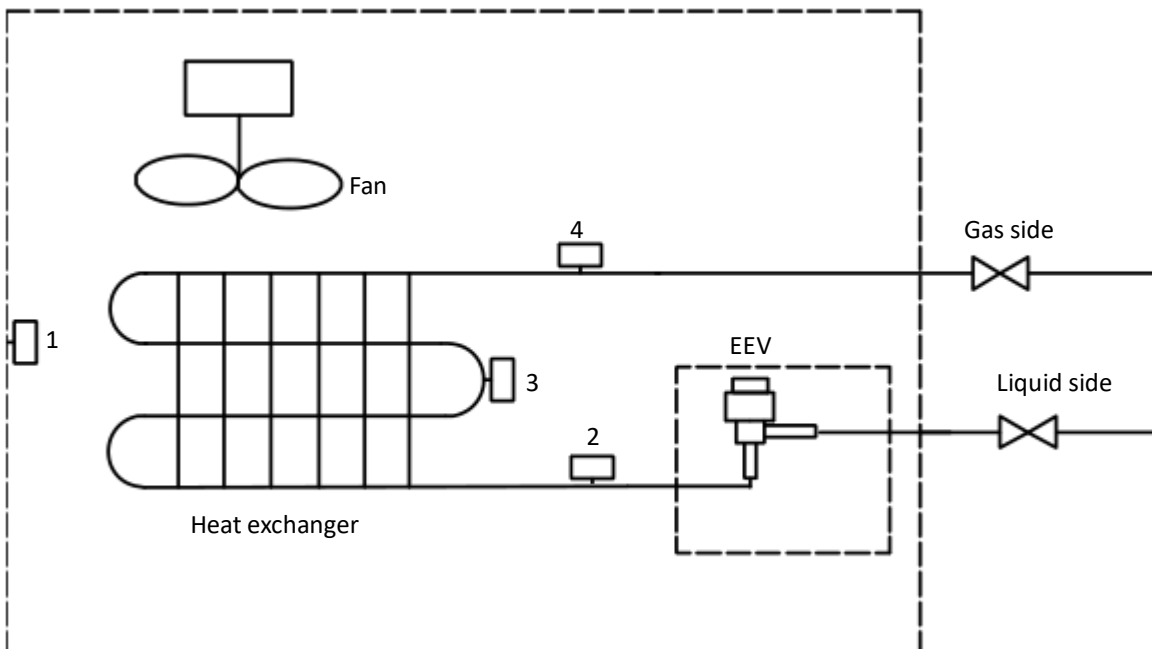

Legend		
1	T1	Inlet Air Temp. Sensor
2	T2A	Liquid Pipe Temp. Sensor
3	T2	Middle Pipe Temp. Sensor
4	T2B	Gas Pipe Temp. Sensor



# OMEGA Indoor Units

## 5 Wiring Diagram

Figure 5.1: VEWM006(008,010,012,015,019,24,27) Wall mounted wiring diagram

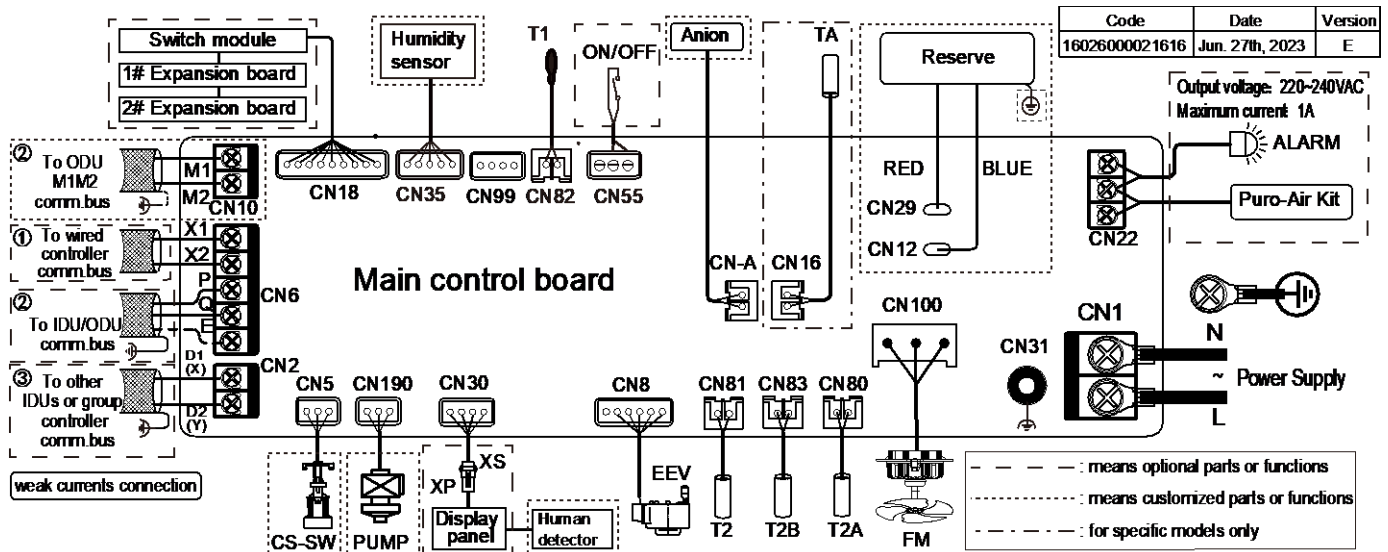

Code	Description	Code	Description
ALARM	Alarm Output	T2	Middle Pipe Temp. Sensor
Anion	Ionic Sterilization Module	T2A	Liquid Pipe Temp. Sensor
CS-SW	Water Level Switch	T2B	Gas Pipe Temp. Sensor
EEV	Electronic Expansion Valve	TA	Discharge Air Temp. Sensor*
FM	DC Fan Motor	ON/OFF	Remote ON/OFF
T0	Outdoor Air Temp. Sensor*	XS/XP	Connectors
T1	Inlet Air Temp. Sensor		

\* Indicates that this sensor is only available for Fresh Air Processing Unit.

### Notes for installers and service engineers

#### Caution

- All installation, servicing and maintenance must be carried out by competent and suitably qualified, certified and accredited professionals and in accordance with all applicable legislation.
- Units should be grounded in accordance with all applicable legislation. Metal and other conductive components should be insulated in accordance with all applicable legislation.
- Power supply wiring should be securely fastened at the power supply terminals – loose power supply wiring would represent a fire risk.
- After installation, servicing or maintenance, the electric control box cover should be closed. Failing to close the electric control box cover risks fire or electric shock.
- PQ and M1M2 communication ports both are used for indoor and outdoor communication, and only one of them can be used at a time. Meanwhile, be sure to connect the same communication ports (PQ to PQ; M1M2 to M1M2) in case of damage of the main control board.
- D1D2 communication ports are used for group control communication. When connecting the group controller, the D1D2 port of the indoor units that are to be group controlled must be connected in daisy chain, and the group controller must be connected to the X1X2 port of one of the indoor units in the group control, and set to group control mode. In addition, D1D2 communication ports can also be connected to the central controller.

## 6 Capacity Tables

### 6.1 Cooling Capacity Table

Table 6.1: VEWM006(008,010,012,015,019,24,27) Wall mounted cooling capacity

Model	Indoor air temperature (°C WB/DB)													
	14/20		16/23		18/26		19/27		20/28		22/30		24/32	
	TC	SC	TC	SC	TC	SC	TC	SC	TC	SC	TC	SC	TC	SC
VEWM006T0A-DWV015	1.4	1.4	1.5	1.4	1.5	1.4	1.5	1.3	1.6	1.3	1.6	1.2	1.6	1.1
VEWM008T0A-DWV022	2.0	1.9	2.1	2.0	2.2	2.0	2.2	1.9	2.3	1.9	2.3	1.7	2.4	1.7
VEWM010T0A-DWV028	2.5	2.4	2.7	2.5	2.8	2.5	2.8	2.4	2.9	2.4	2.9	2.2	3.0	2.1
VEWM012T0A-DWV036	3.2	3.1	3.4	3.1	3.6	3.2	3.6	3.0	3.7	3.0	3.8	2.8	3.9	2.7
VEWM015T0A-DWV045	4.0	3.7	4.3	3.8	4.5	3.8	4.5	3.7	4.6	3.6	4.7	3.4	4.8	3.3
VEWM019T0A-DWV056	5.0	4.6	5.3	4.7	5.6	4.8	5.6	4.6	5.7	4.5	5.8	4.2	6.0	4.1
VEWM024T0A-DWV071	6.3	5.9	6.7	6.0	7.0	6.0	7.1	5.9	7.2	5.7	7.4	5.4	7.6	5.2
VEWM027T0A-DWV080	7.1	6.6	7.6	6.8	7.9	6.8	8.0	6.6	8.1	6.4	8.3	6.1	8.5	5.8

Abbreviations:

TC: Total capacity (kW)

SC: Sensible capacity (kW)

Notes:

1. Shaded cells indicate rating condition

### 6.2 Heating Capacity Table

Table 6.2: VEWM006(008,010,012,015,019,24,27) Wall mounted heating capacity

Model	Indoor air temperature (°C DB)					
	16	18	20	21	22	24
	SHC	SHC	SHC	SHC	SHC	SHC
VEWM006T0A-DWV015	1.8	1.8	1.7	1.6	1.6	1.5
VEWM008T0A-DWV022	2.6	2.6	2.4	2.3	2.3	2.1
VEWM010T0A-DWV028	3.4	3.4	3.2	3.1	3.0	2.8
VEWM012T0A-DWV036	4.2	4.2	4.0	3.8	3.8	3.5
VEWM015T0A-DWV045	5.3	5.3	5.0	4.8	4.7	4.4
VEWM019T0A-DWV056	6.7	6.6	6.3	6.1	5.9	5.5
VEWM024T0A-DWV071	8.5	8.4	8.0	7.8	7.5	7.0
VEWM027T0A-DWV080	9.5	9.5	9.0	8.7	8.5	7.8

Abbreviations:

SHC: Sensible Heat Capacity

Notes:

1. Shaded cells indicate rating condition

# OMEGA Indoor Units

## 7 Electrical Characteristics

Table 7.1: VEWM006(008,010,012,015,019,24,27) Wall mounted electrical characteristics

Model	Power supply						Indoor Fan Motor	
	Hz	Volts	Min. volts	Max. volts	MCA	MFA	Rated motor output (W)	FLA
VEWM006T0A-DWV015	50/60	220-240	198	264	0.28	15	20	0.22
VEWM008T0A-DWV022	50/60	220-240	198	264	0.29	15	20	0.23
VEWM010T0A-DWV028	50/60	220-240	198	264	0.36	15	20	0.29
VEWM012T0A-DWV036	50/60	220-240	198	264	0.39	15	20	0.31
VEWM015T0A-DWV045	50/60	220-240	198	264	0.41	15	20	0.33
VEWM019T0A-DWV056	50/60	220-240	198	264	0.51	15	20	0.41
VEWM024T0A-DWV071	50/60	220-240	198	264	0.69	15	50	0.55
VEWM027T0A-DWV080	50/60	220-240	198	264	0.98	15	50	0.78

Abbreviations:

MCA: Minimum Circuit Amps

MFA: Maximum Fuse Amps

FLA: Full Load Amps

## 8 Sound Levels

### 8.1 Overall

Model name	Sound pressure levels dB(A)						
	SSH	SH	H	M	L	SL	SSL
VEWM006T0A-DWV015	32	31	30	30	29	28	27
VEWM008T0A-DWV022	33	32	31	30	29	28	27
VEWM010T0A-DWV028	35	34	33	32	31	30	28
VEWM012T0A-DWV036	37	36	34	33	31	30	28
VEWM015T0A-DWV045	37	35	33	32	31	30	29
VEWM019T0A-DWV056	41	39	37	35	33	31	29
VEWM024T0A-DWV071	44	42	40	38	36	34	32
VEWM027T0A-DWV080	45	43	41	39	37	35	32

Figure 8.1: VEWM006(008,010,012,015,019,24,27) Wall mounted sound pressure level measurement

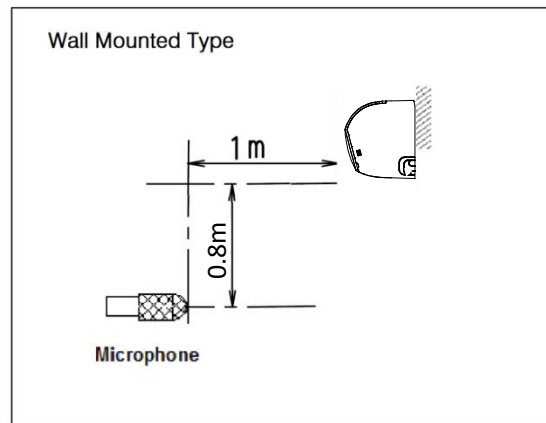

### 8.2 Octave Band Levels

Figure 8.2: VEWM006T0A-DWV015 octave band levels

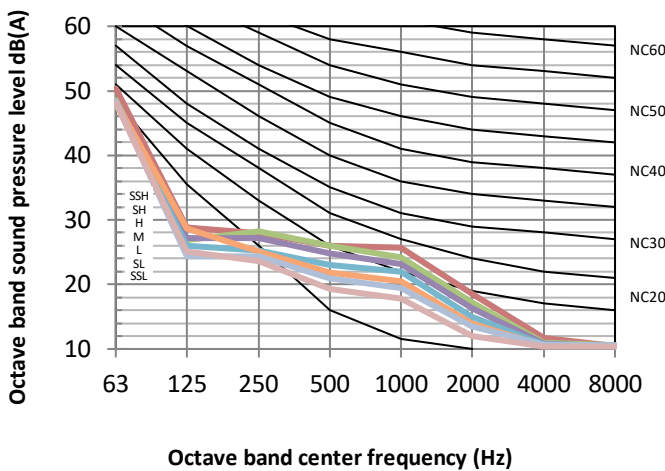
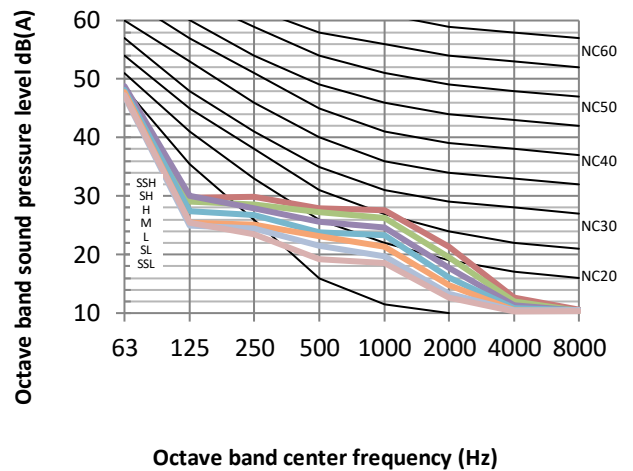

Figure 8.3: VEWM008T0A-DWV022 octave band levels



# OMEGA Indoor Units

Figure 8.4: VEWM010T0A-DWV028 octave band levels

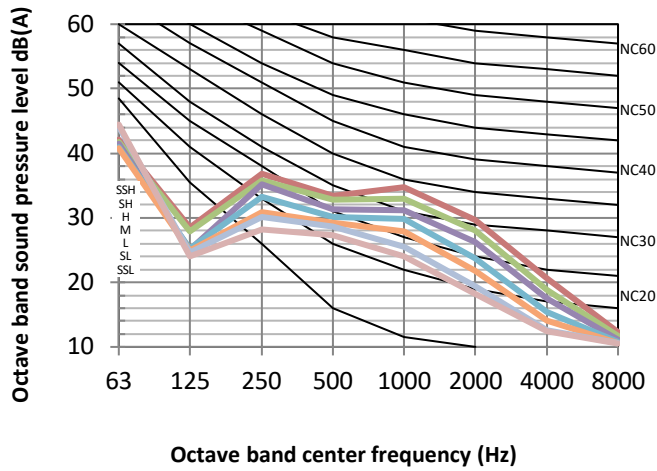

Figure 8.5: VEWM012T0A-DWV036 octave band levels

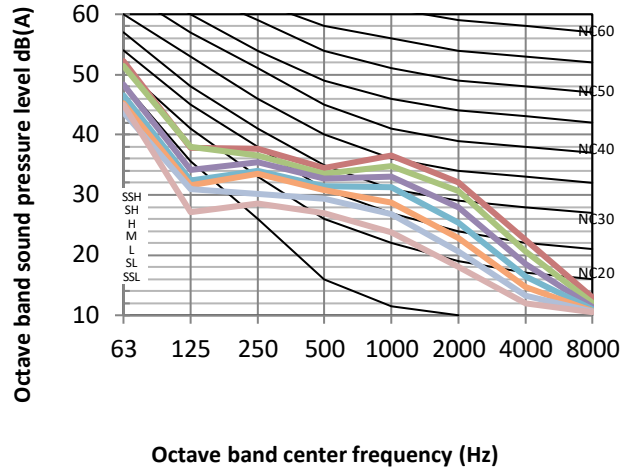

Figure 8.6: VEWM015T0A-DWV045 octave band levels

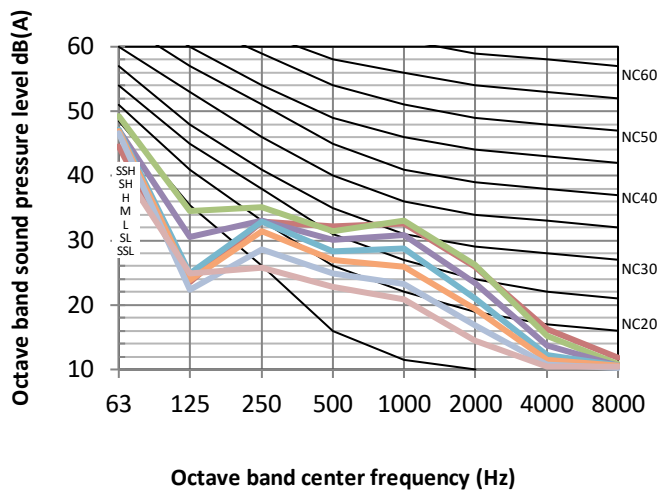
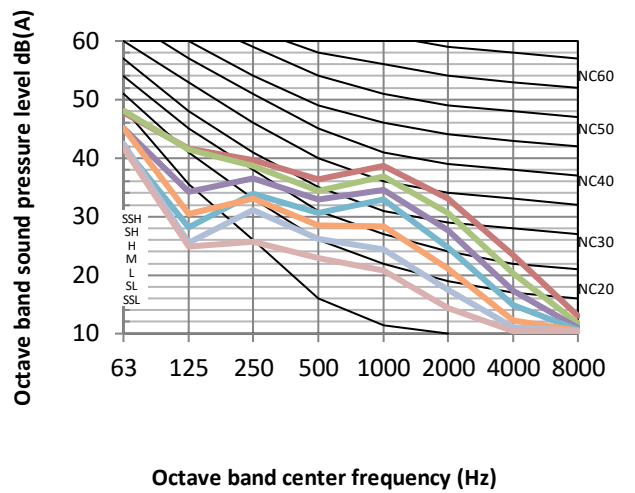

Figure 8.7: VEWM019T0A-DWV056 octave band levels



# 9 Temperature and Airflow Distributions

## 9.1 Simulate condition

Table 9.1: VEWM006(008,010,012,015,019,24,27) Wall

Model name	Room size (m)	Ceiling height (m)	Flow angle (Cooling/Heating)	Placing
VEWM006T0A-DWV015	4×4	2.7	58°/88°	Wall mounted
VEWM008T0A-DWV022	4.5×4.5	2.7	58°/88°	Wall mounted
VEWM010T0A-DWV028	5×5	2.7	58°/88°	Wall mounted
VEWM012T0A-DWV036	5.5×5.5	2.7	58°/88°	Wall mounted
VEWM015T0A-DWV045	6×6	2.7	58°/88°	Wall mounted
VEWM019T0A-DWV056	8×8	2.7	58°/88°	Wall mounted
VEWM024T0A-DWV071	8×8	2.7	58°/88°	Wall mounted
VEWM027T0A-DWV080	8×8	2.7	58°/88°	Wall mounted

Note:

- These figures are based on software simulation. They show typical temperature and airflow distributions in the conditions above. In the actual installation, they may differ from these figures under the influence of air temperature conditions, ceiling height, cooling/heating load, obstacles, etc.

## 9.2 Airflow distributions (unit: m/s)

Figure 9.1: VEWM006T0A-DWV015 cooling at 300S

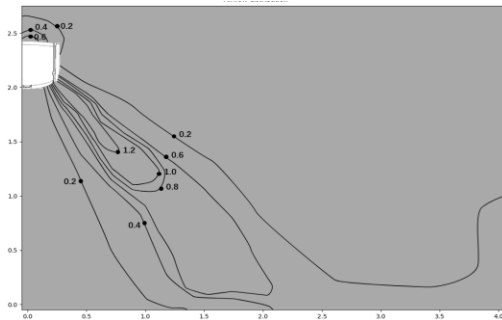

Figure 9.3: VEWM008T0A-DWV022 cooling at 300S

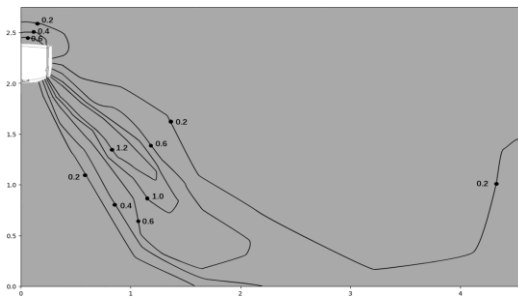

Figure 9.5: VEWM010T0A-DWV028 cooling at 300S

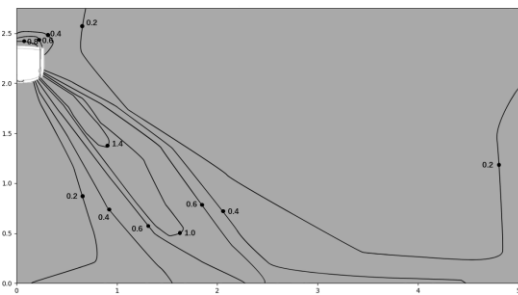

Figure 9.2: VEWM006T0A-DWV015 heating at 300S

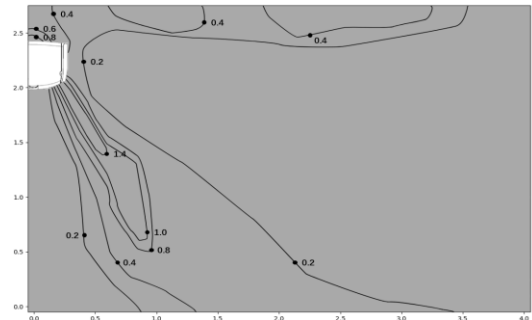

Figure 9.4: VEWM008T0A-DWV022 heating at 300S

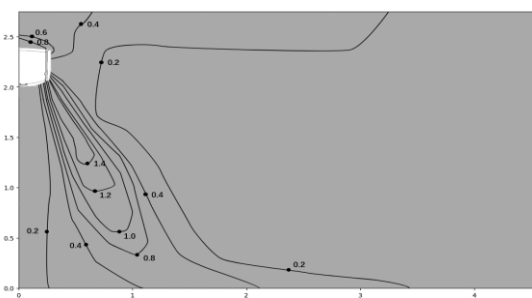
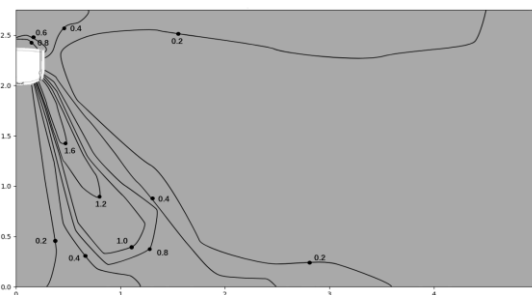

Figure 9.6: VEWM010T0A-DWV028 heating at 300S



# OMEGA Indoor Units

Figure 9.7: VEWM012T0A-DWV036 cooling at 300S

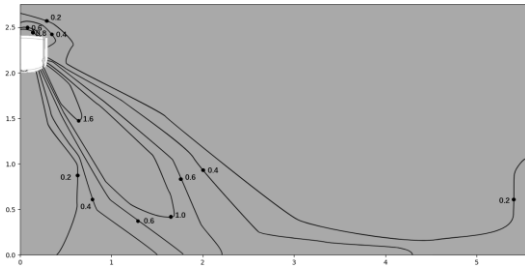

Figure 9.8: VEWM012T0A-DWV036 heating at 300S

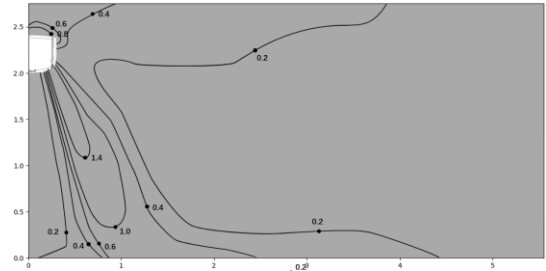

Figure 9.9: VEWM015T0A-DWV045 cooling at 300S

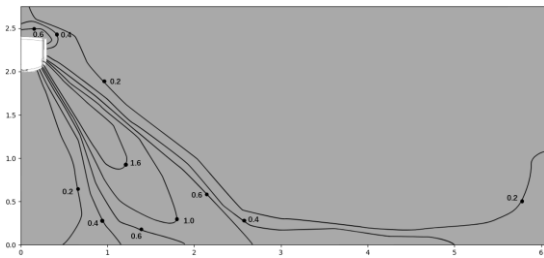

Figure 9.10: VEWM015T0A-DWV045 heating at 300S

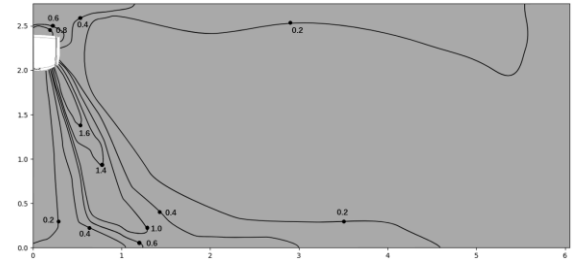

Figure 9.11: VEWM019T0A-DWV056 cooling at 300S

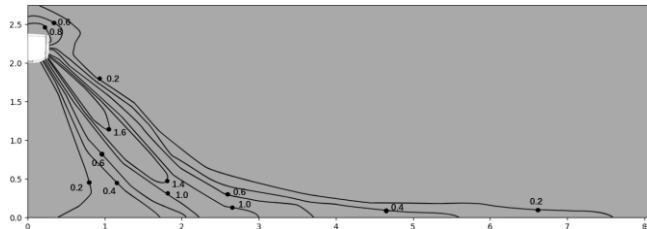

Figure 9.12: VEWM019T0A-DWV056 heating at 300S

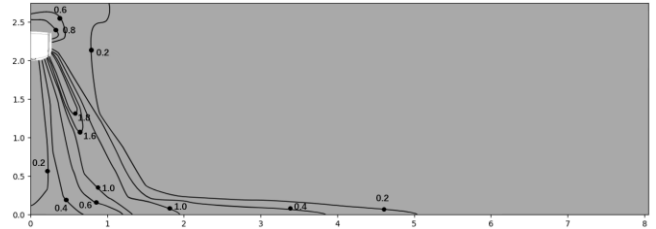

Figure 9.13: VEWM024T0A-DWV071 cooling at 300S

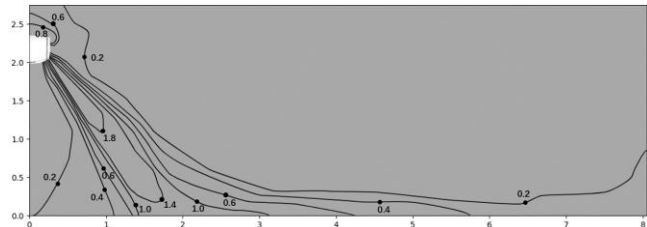

Figure 9.14: VEWM024T0A-DWV071 heating at 300S

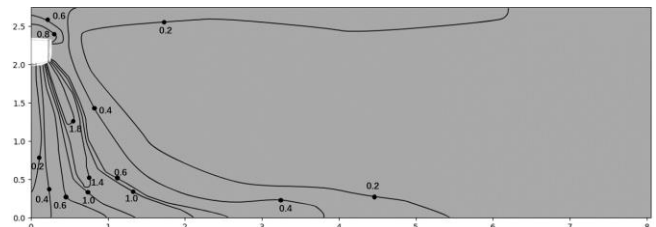

Figure 9.15: VEWM027T0A-DWV080 cooling at 300S

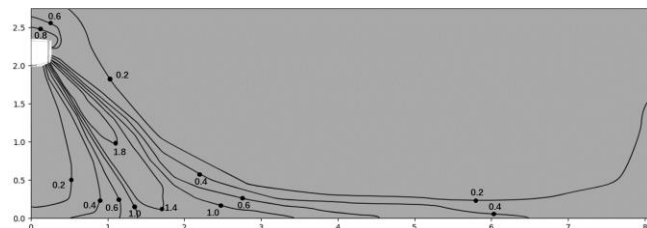
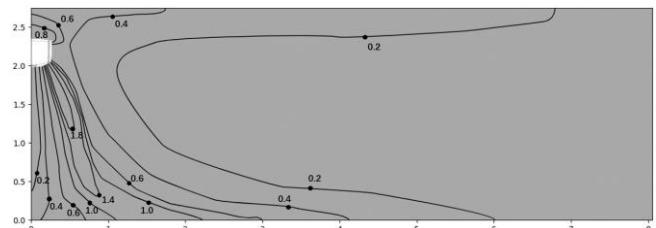

Figure 9.16: VEWM027T0A-DWV080 heating at 300S



9.3 Temperature distributions

Figure 9.17: VEWM006T0A-DWV015 cooling at 300S

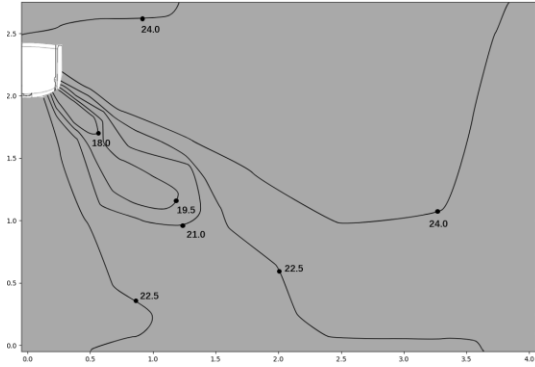

Figure 9.18: VEWM006T0A-DWV015 heating at 300S

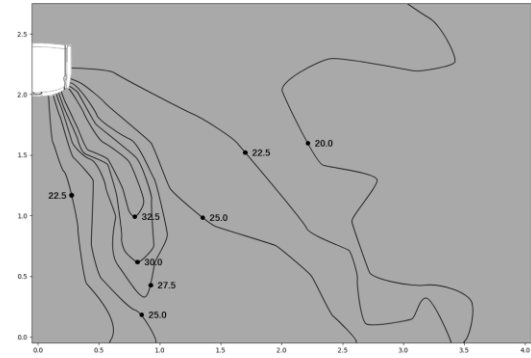

Figure 9.19: VEWM008T0A-DWV022 cooling at 300S

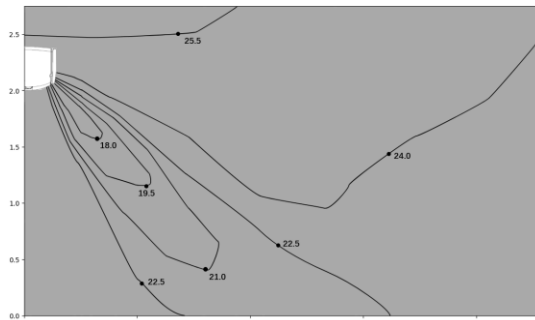

Figure 9.20: VEWM008T0A-DWV022 heating at 300S

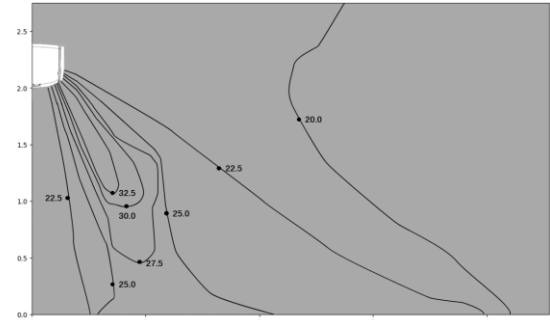

Figure 9.21: VEWM010T0A-DWV028 cooling at 300S

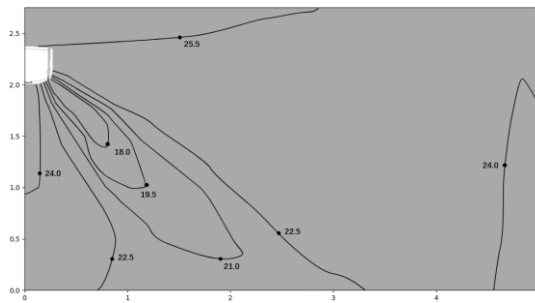

Figure 9.22: VEWM010T0A-DWV028 heating at 300S

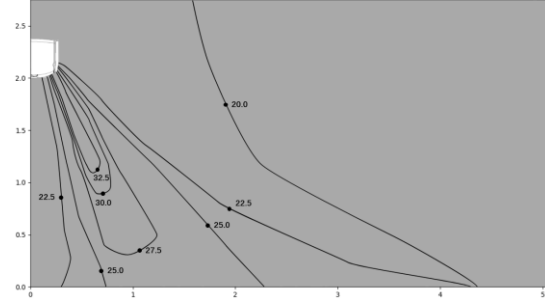

Figure 9.23: VEWM012T0A-DWV036 cooling at 300S

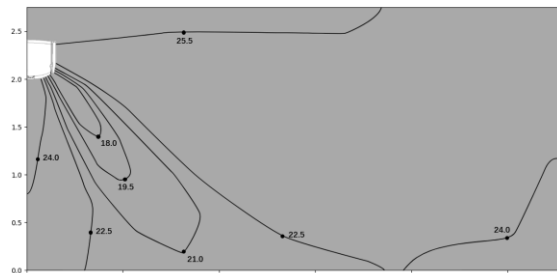

Figure 9.24: VEWM012T0A-DWV036 heating at 300S

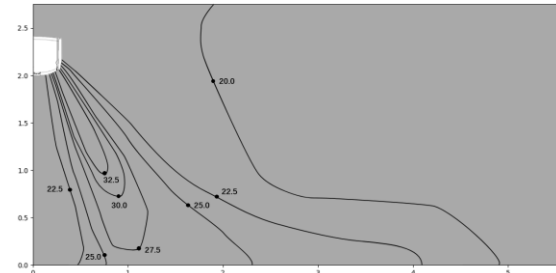

Figure 9.25: VEWM015T0A-DWV045 cooling at 300S

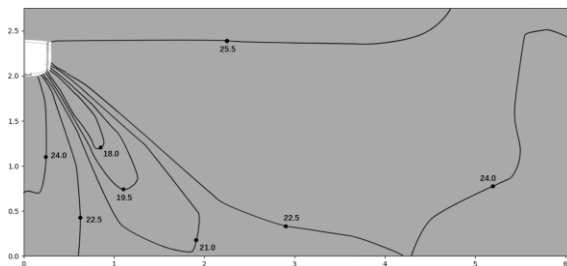

Figure 9.26: VEWM015T0A-DWV045 heating at 300S





# OMEGA Indoor Units

Figure 9.27: VEWM019T0A-DWV056 cooling at 300S

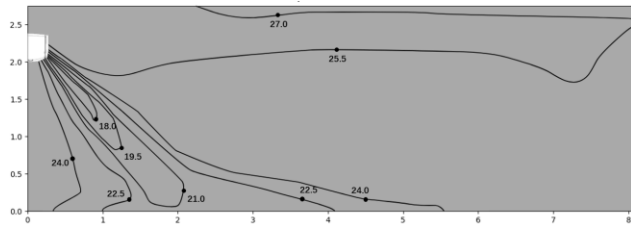

Figure 9.28: VEWM019T0A-DWV056 heating at 300S

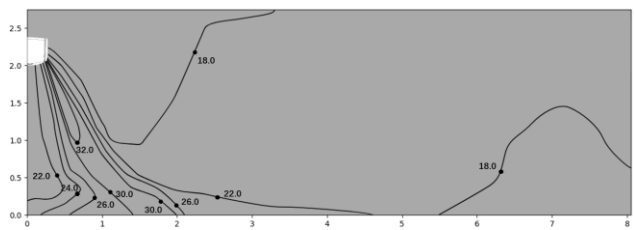

Figure 9.29: VEWM024T0A-DWV071 cooling at 300S

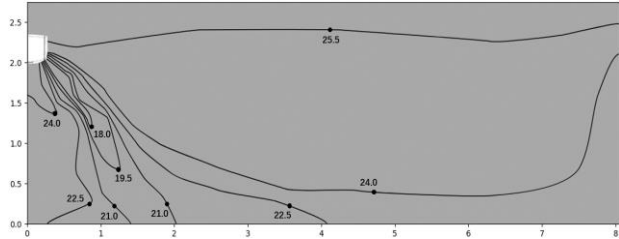
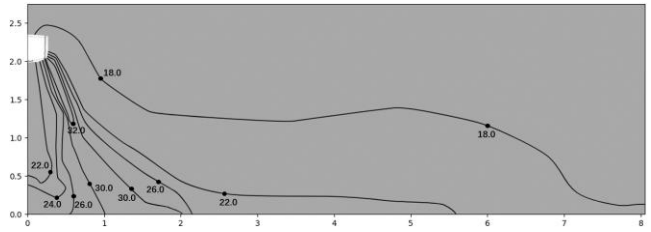

Figure 9.30: VEWM024T0A-DWV071 heating at 300S





**OMEGA**  
ENVIRONMENTAL  
TECHNOLOGIES LLC.

17702 Mitchell North, #101  
Irvine, CA. 92614 .USA  
Tel: 714 795 2830  
Fax: 714 966 1646  
info@omegavrf.com  
www.omegavrf.com

**OTEC**<sup>TM</sup>  
AIR CONDITIONING

**Showroom & Technology Center**

11380 Interchange Circle North  
Miramar, FL 33025 .USA  
Tel: 305 901 1270  
Fax: 954 212 8280  
info@otecomega.com  
www.otecomega.com

VEWMT0A-TM1D0823