

APRH Series

Rooftop Package Unit

Service Manual

208~230V/3/60Hz

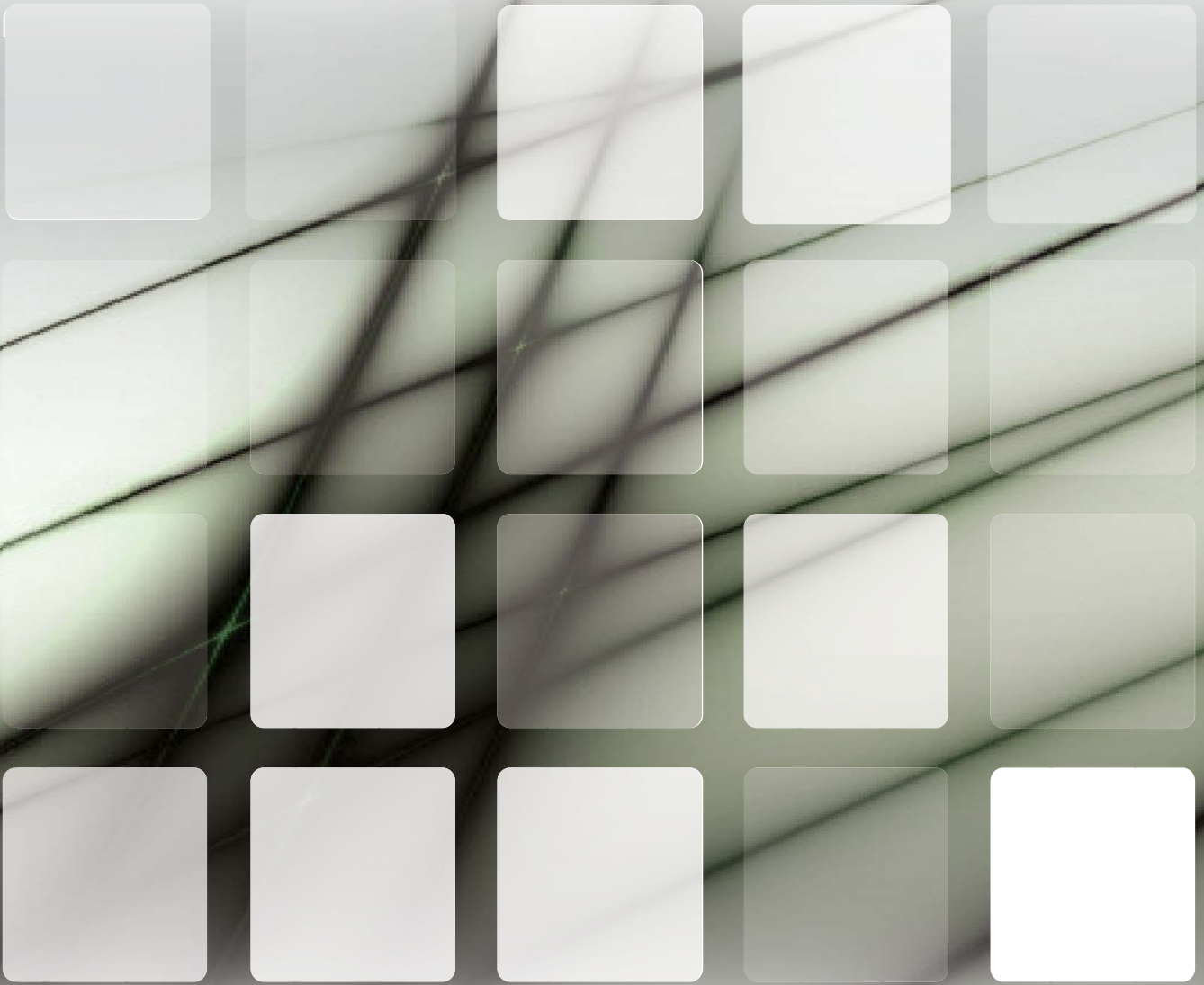

Content

Part. 1 General information.....	3
Part. 2 Controller.....	39

Part. 1 General information

1. Product lineup	4
2. External Appearance	4
3. Features	6
4. Wiring diagrams	8
5. Refrigerant cycle diagram	18
6. Duct Work	20
7. Electrical Wiring	20
8. Start-up	25
9. Safety control	26
10. Maintenance	35

1. Product lineup

Nominal ton	Model	Function	Air outlet	Power supply
4	APRH048C7A-DC1141	Cooling only	Side discharge	380~415V 3Ph 50Hz
5	APRH060C7A-DC1170	Cooling only	Side discharge	
6.25	APRH075C7A-DD1220	Cooling only	Side discharge	
7.5	APRH090C7A-DD1260	Cooling only	Side discharge	
8.5	APRH105C7A-DD1300	Cooling only	Side discharge	
10	APRH120C7A-DD1350	Cooling only	Side discharge	
12.5	APRH150C7A-DD1440	Cooling only	Side discharge	
15	APRH180C7A-DD2530	Cooling only	Side discharge	
17.5	APRH210C7A-DD2610	Cooling only	Side discharge	
20	APRH240C7A-DD2700	Cooling only	Side discharge	
25	APRH300C7A-DD2870	Cooling only	Side discharge	
30	APRH360C7A-DD3105	Cooling only	Side discharge	

Notes: Please refer to specification tables for accurate cooling capacity with kW or Btu/h.

2. External Appearances



4&5ton



6.2&7.5ton



8.5&10ton



12.5&15ton



17.5&20ton



25&30ton

3. Features

✧ Design flexibility.

Compact design and flanges of air flow inlet and outlet as standard. It is suitable for installation in rooftop and ground.

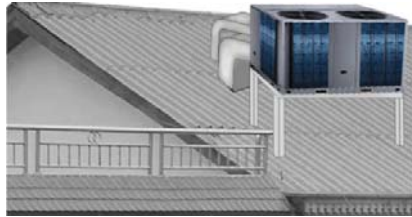

✧ Durable construction.

Pre-painted exterior cabinet panels pass 1000 hours salt spray test for durability. Weather-resistant construction with capped steams and sloped top panels design.

The rooftop package air conditioners with special anti-corrosion treatment are suitable for seaside areas or the areas exposed to acidic substances. (It should be customized.)



✧ Reliable scroll compressor.

Famous brand compressor, it is more reliable. No complex internal suction and discharge valves for quieter operation and higher reliability. Compact and light-weight design, fewer moving parts design.

✧ Adjustable pulley

Through changing the working pitch diameter of the pulley mounted on driver shaft, in turn the revolutions per minute of the driven shaft will increase or decrease to change air volume.

✧ Multi-protection design.

Multi-measurement can ensure units operate normally and reliably:

System current protection;

High/low-pressure switch protection;

Temperature sensor on/off protection, etc.

The three-phase protector can be customized.

-
- ✧ Easy to installation.

Removable access door on the electric box is standard. It is easy to move the cover of the electric box. Only connect the wires of power supply, and no need to connect any signal wires. Reserved external drainage port, quickly and accurately connect the rubber drainage pipe.



- ✧ The unit provides external pressure gauge ports for convenient and fast checking system pressure without removing the panel.



- ✧ System self-diagnostic function.

Press the Check button in Main PCB board, and the LED display of PCB board in unit will display the normal checking code. If the unit is in running with abnormal operation, the LED display will show the error code.

- ✧ Wired controller as standard. Besides the OMEGA controller, other brand thermostat can be matched as optional solution.

- ✧ Centralized control function can be achieved through the centralized controller as optional.

MD-NIM01 should be connected between the rooftop package units and centralized controller.



4. Wiring diagrams

APRH048C7A-DC1141

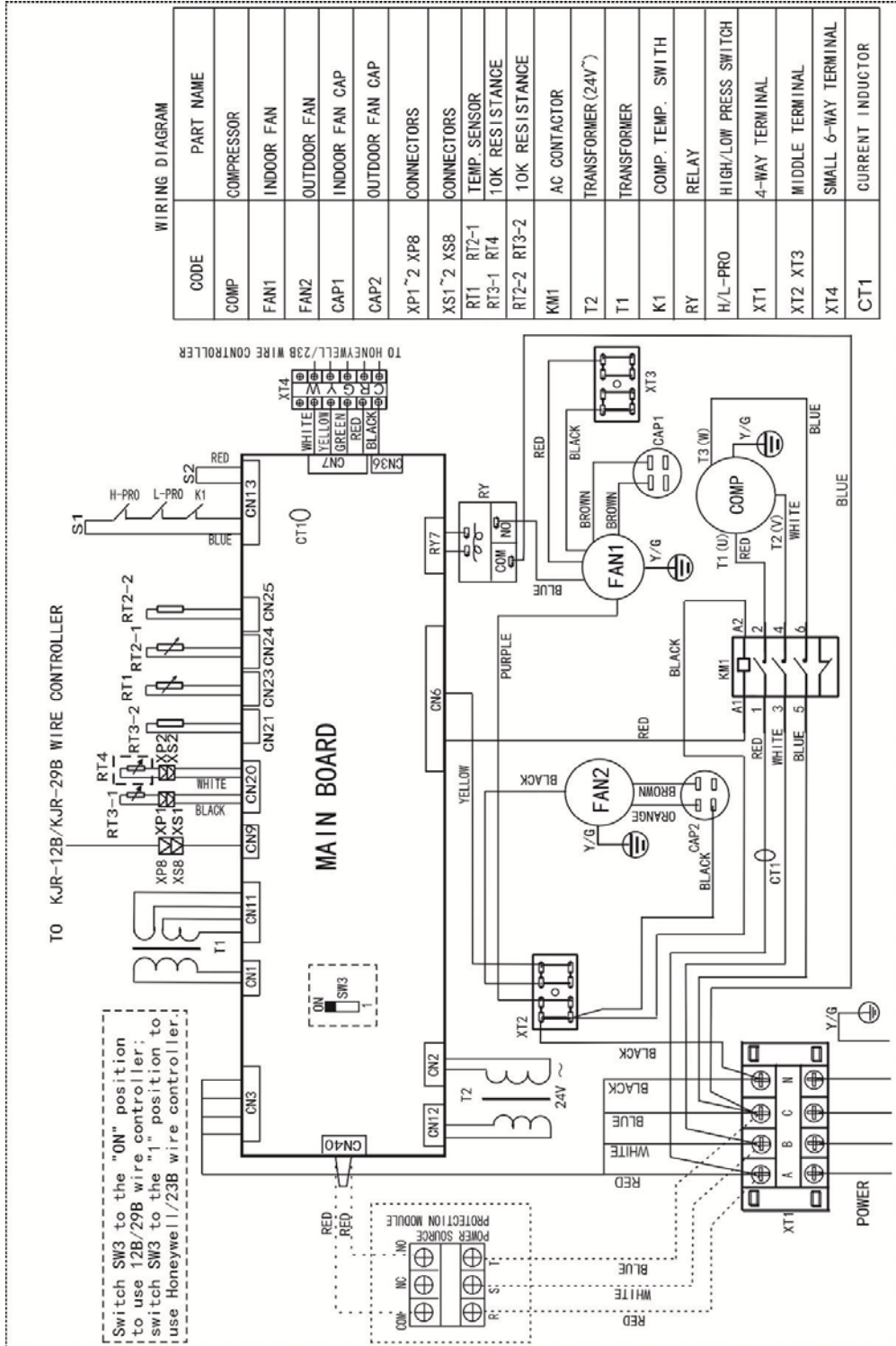

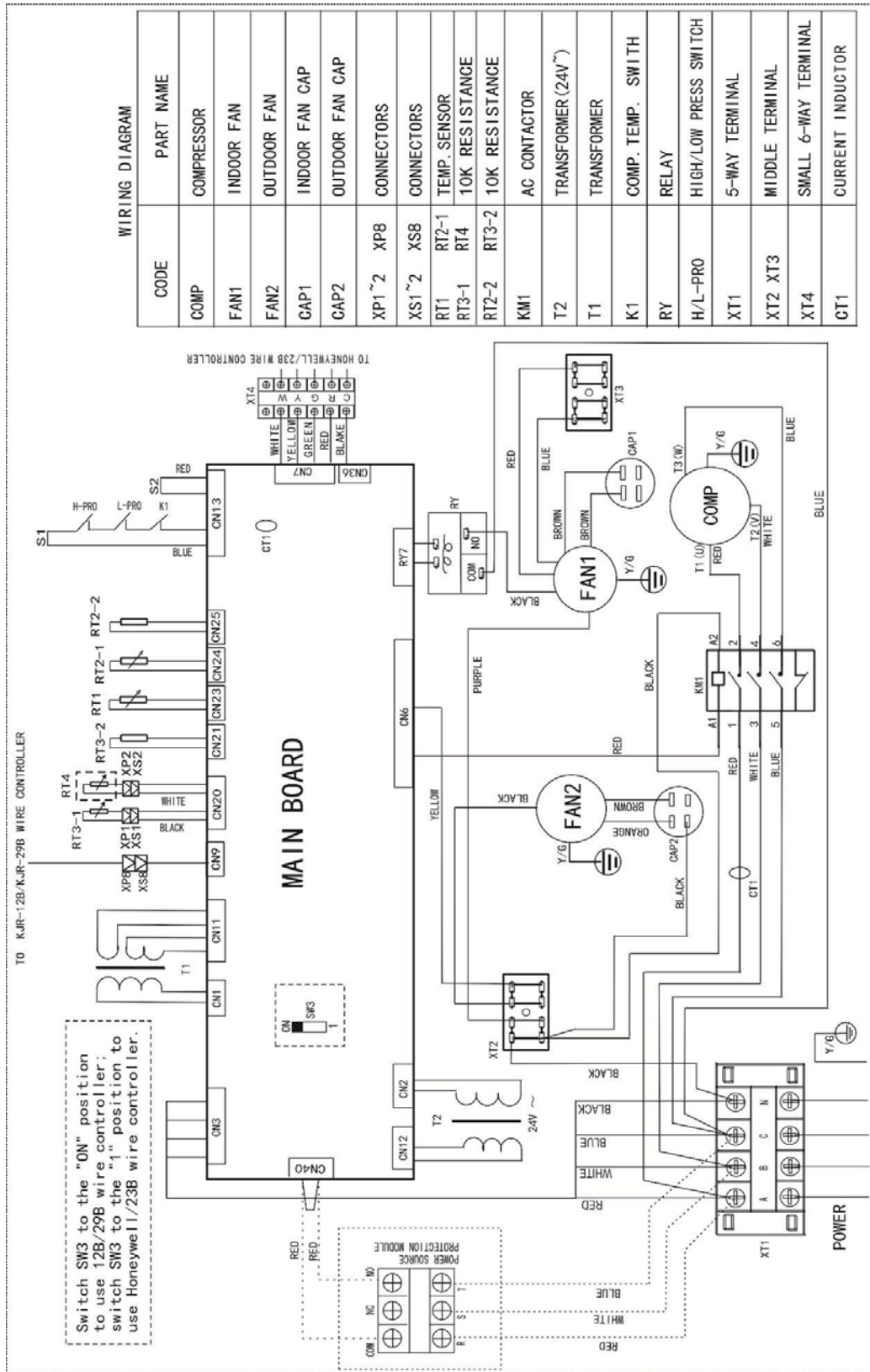

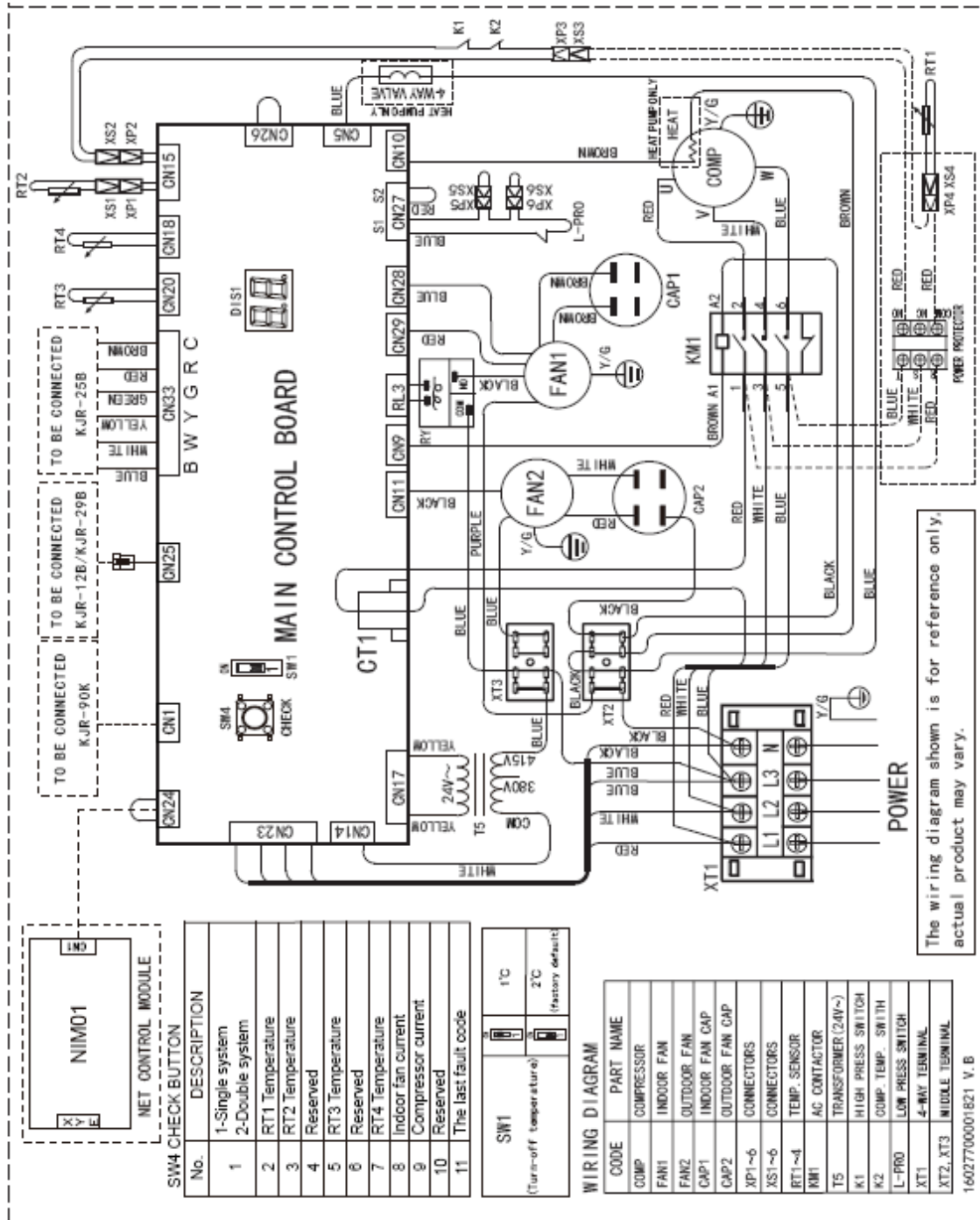

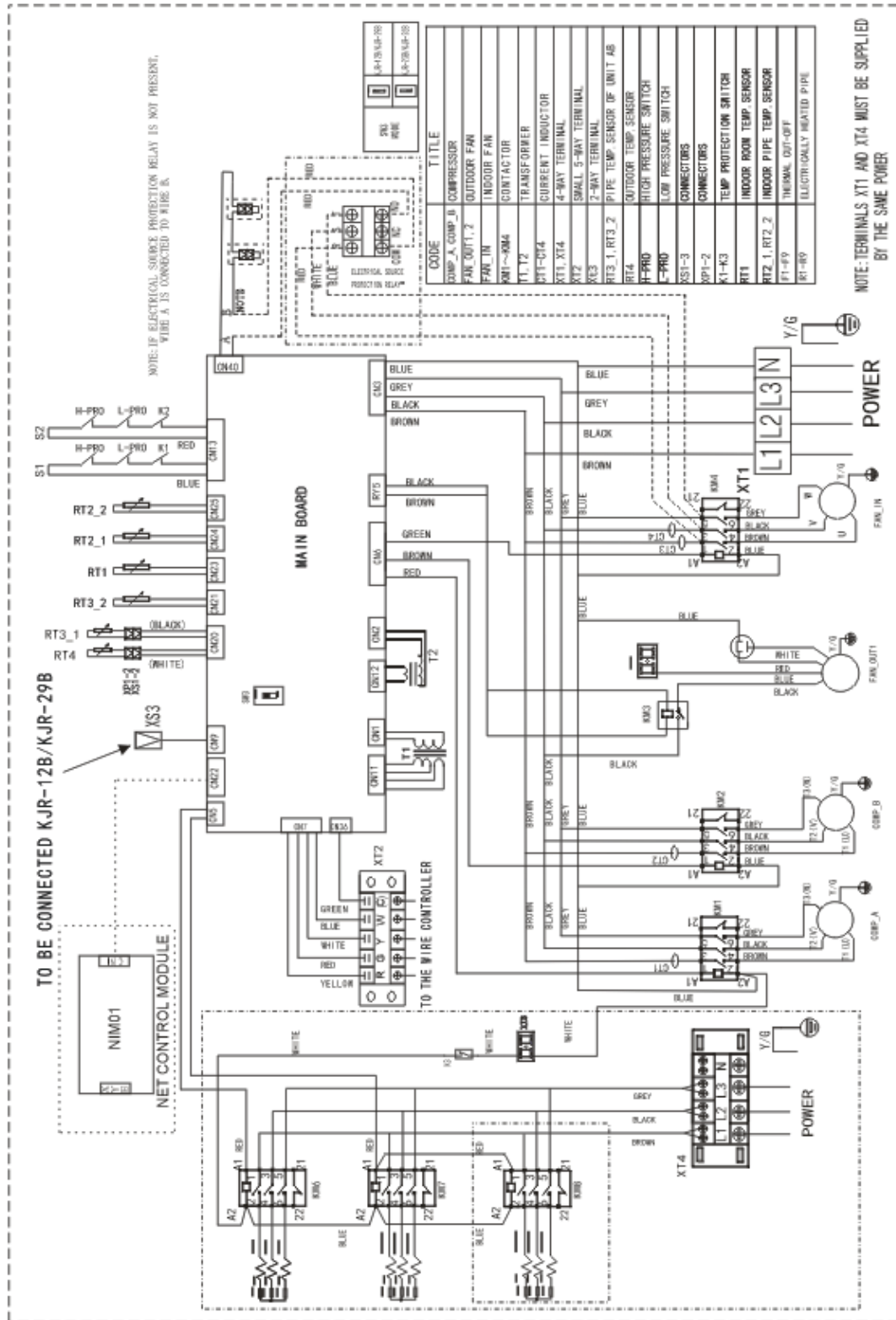

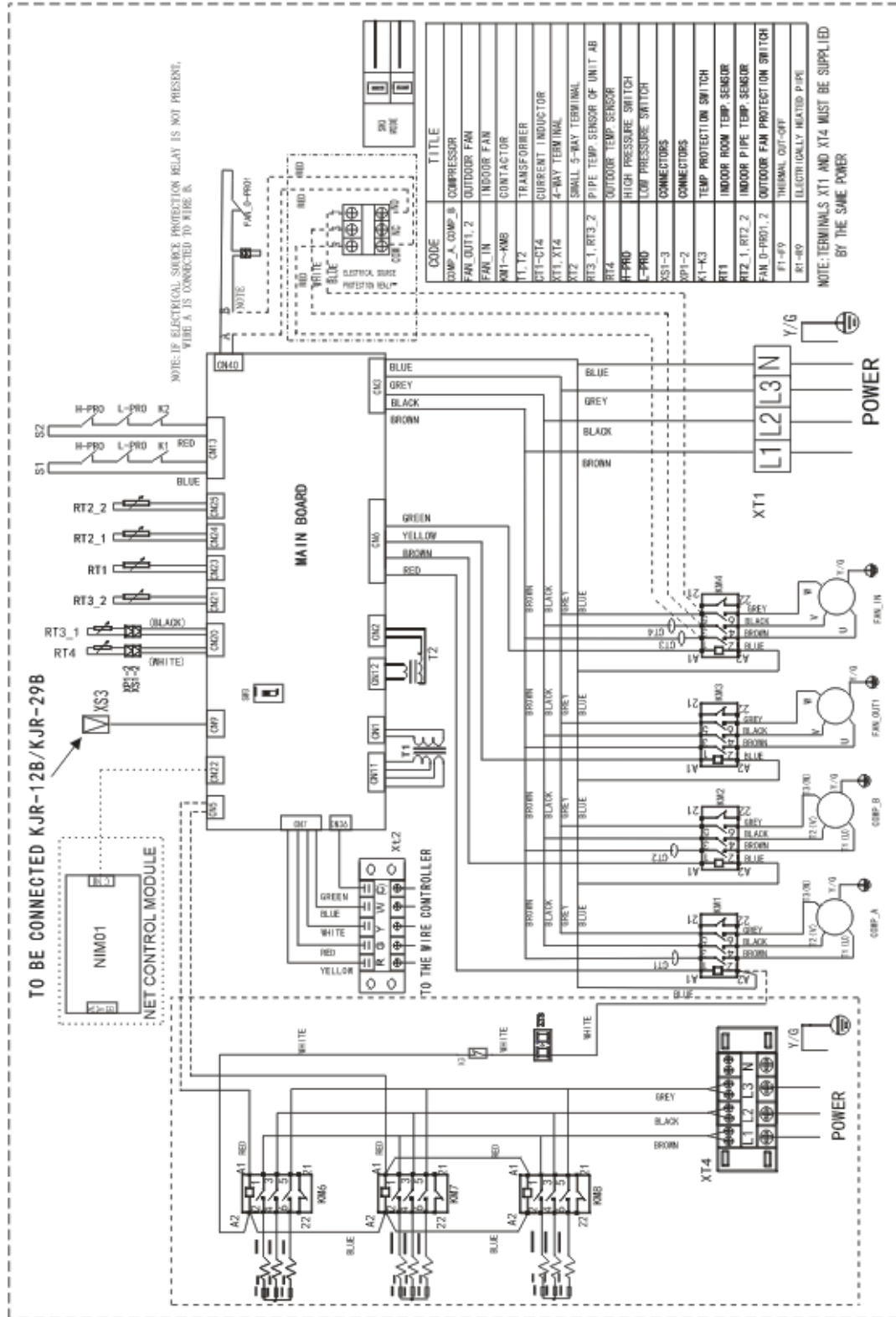

APRH150C7A-DD1440:

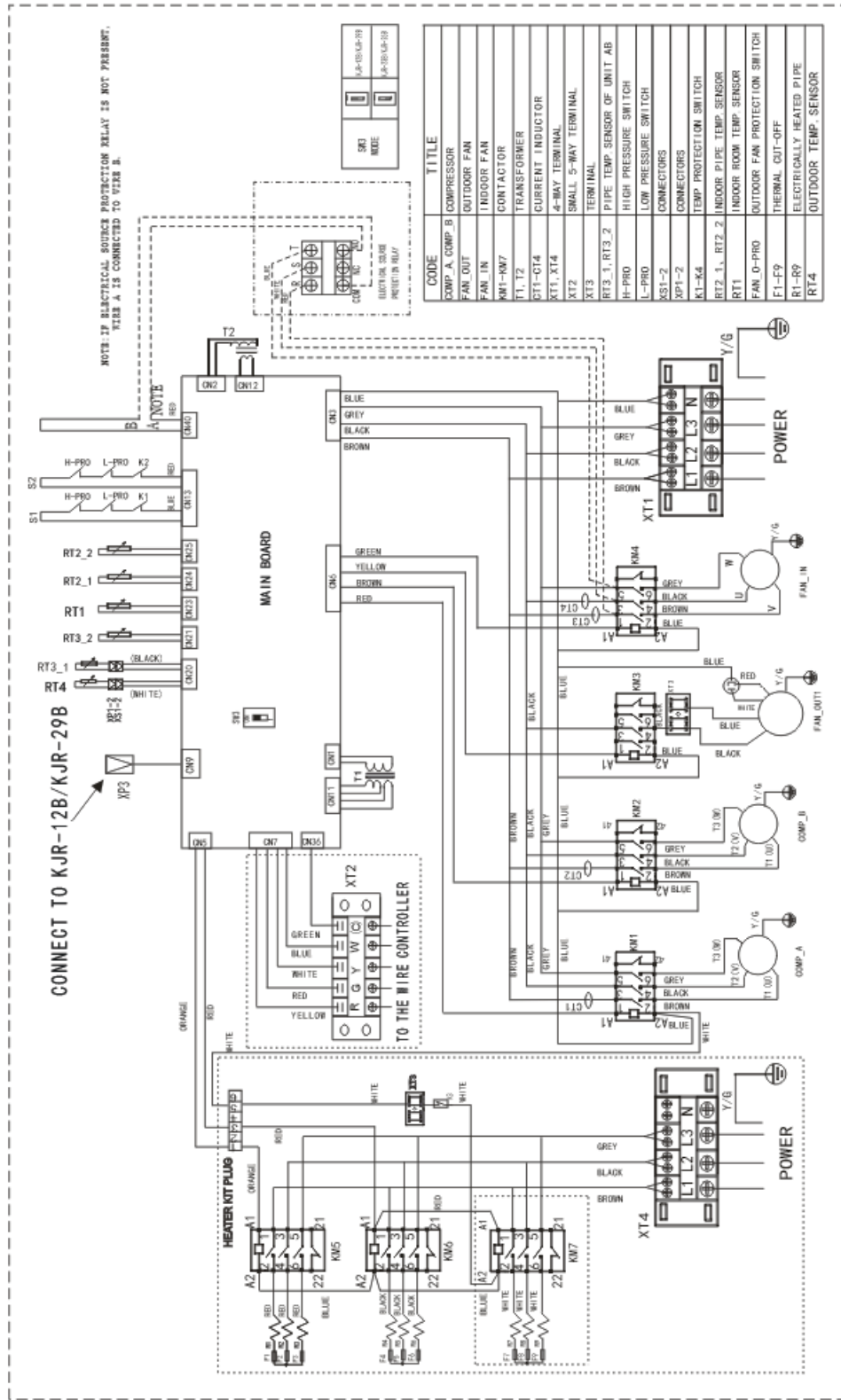

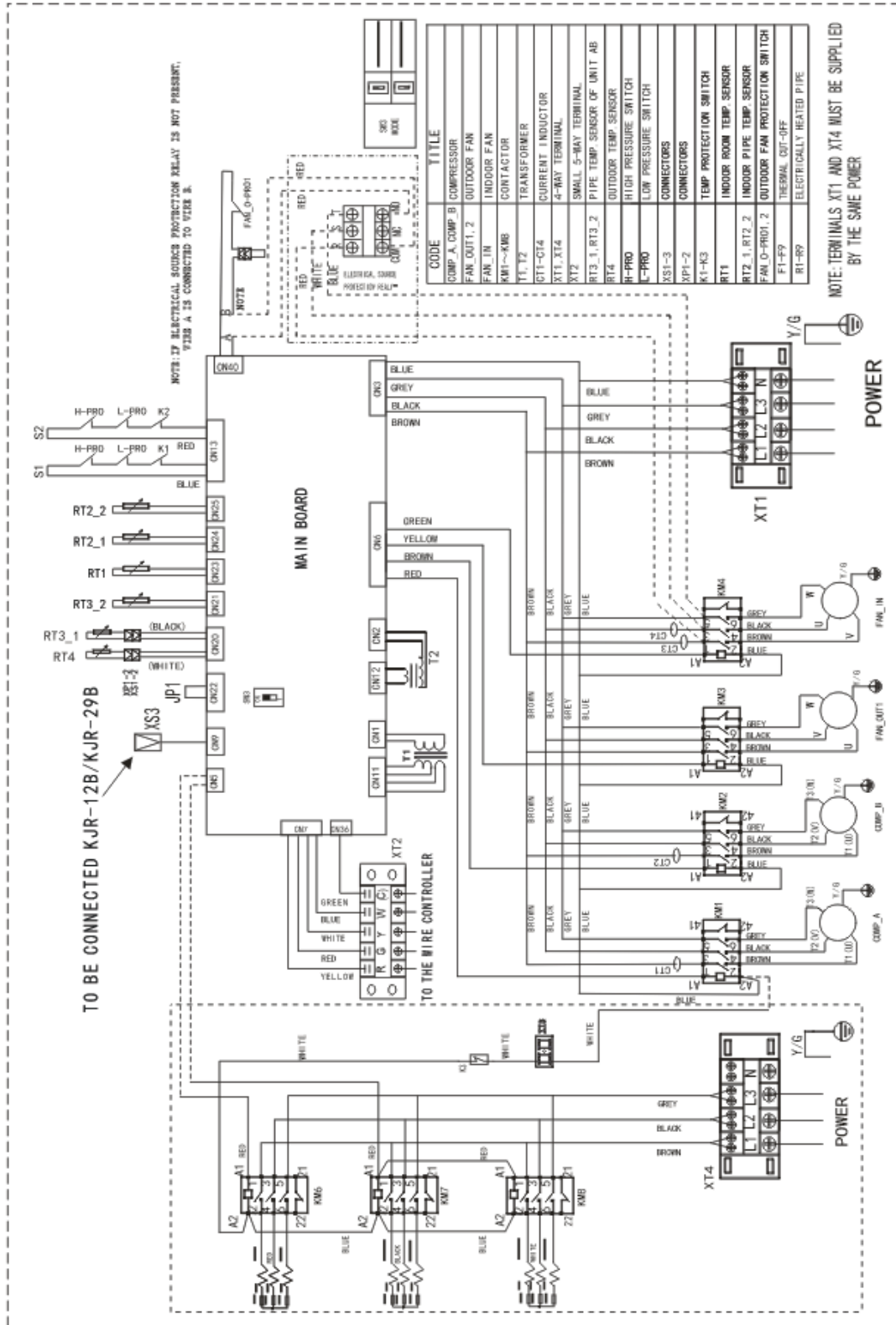

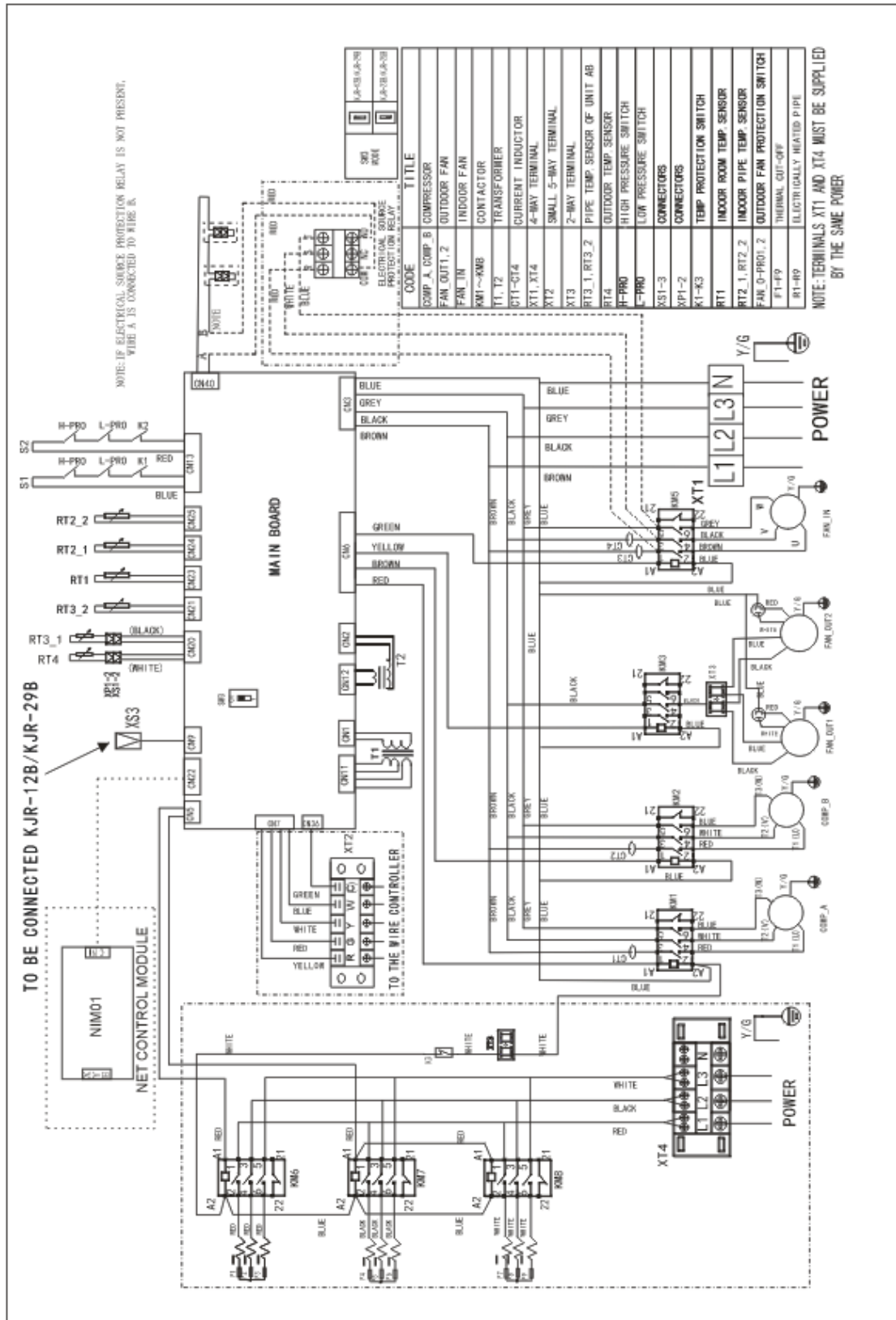

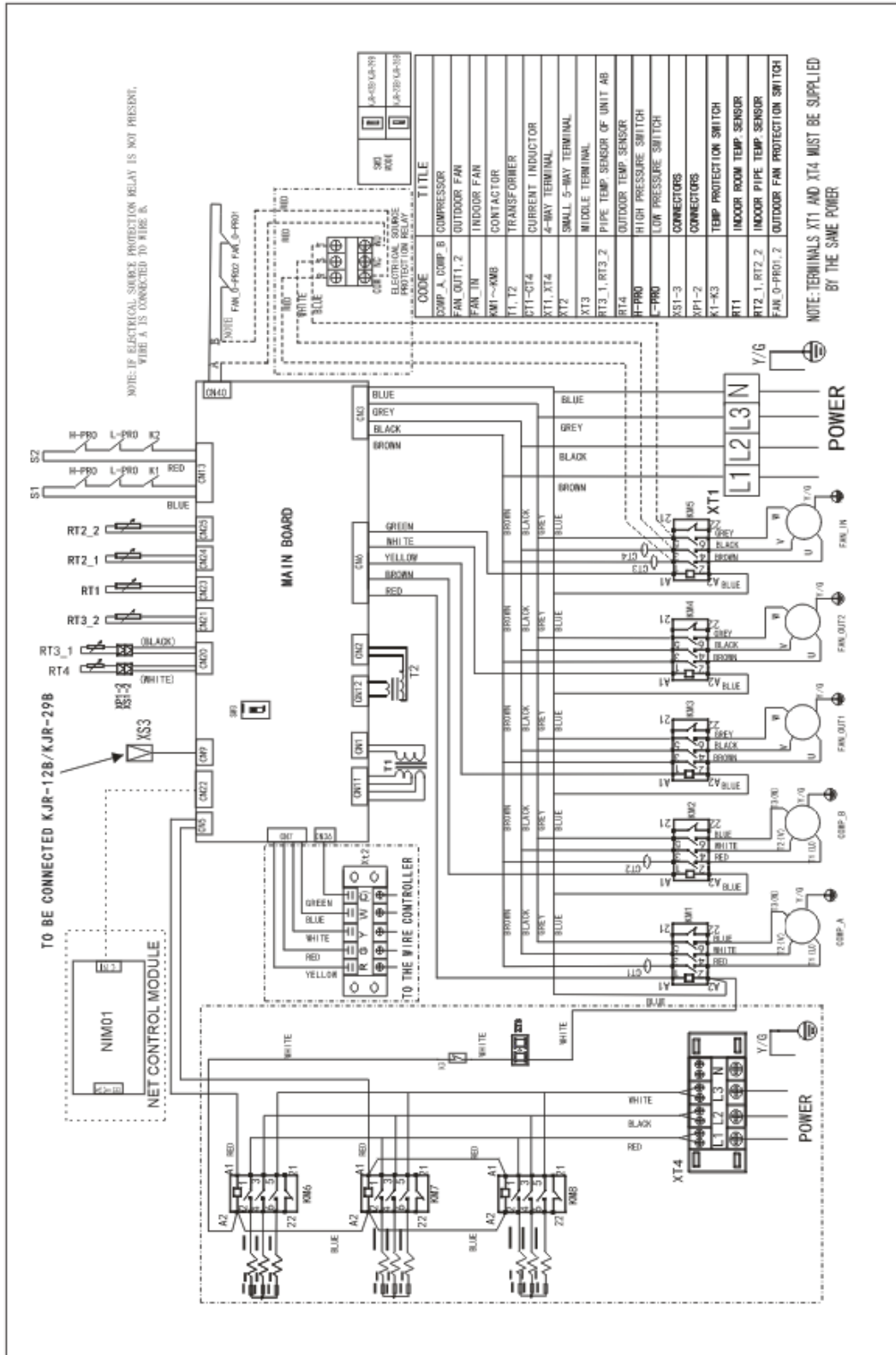

APRH300, 360C7A-D

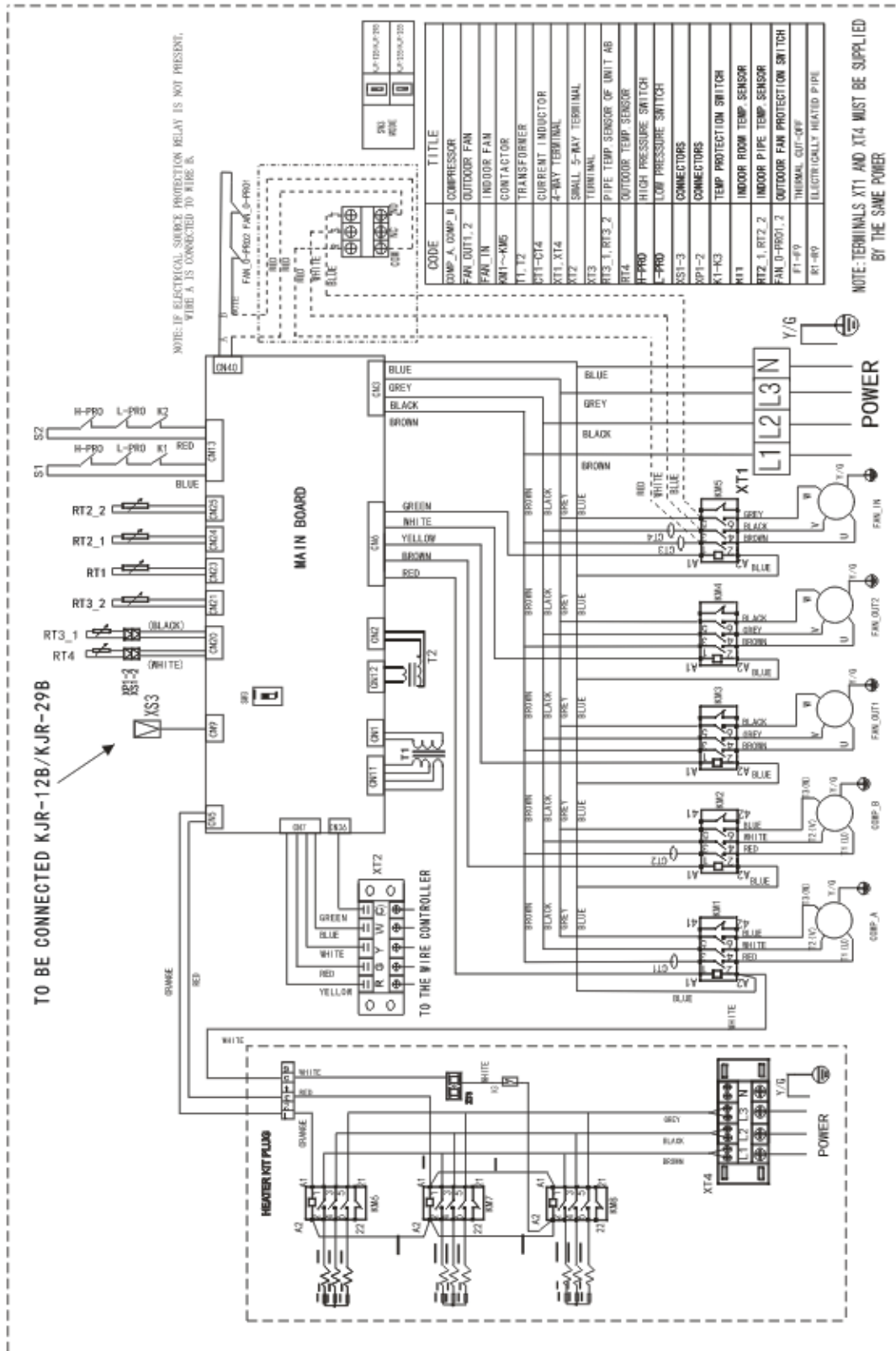

5. Refrigerant cycle diagram

APRH105, 120C7A-D

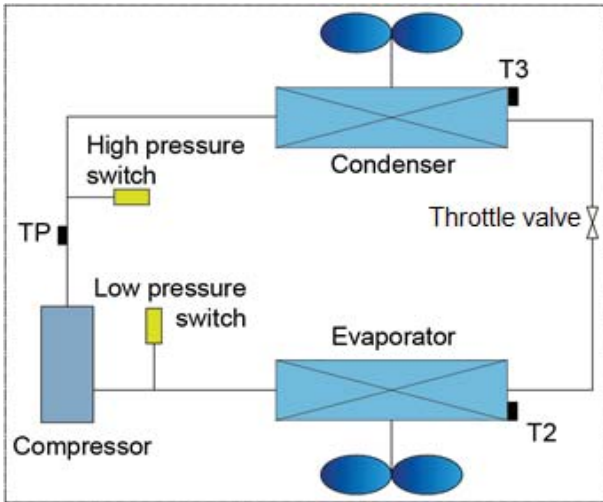

APRH150-240C7A-D:

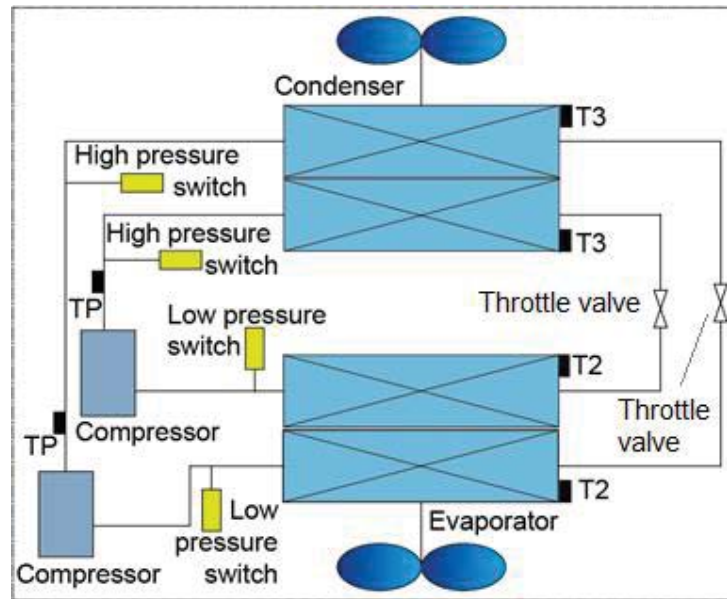

APRH300, 360C7A-D

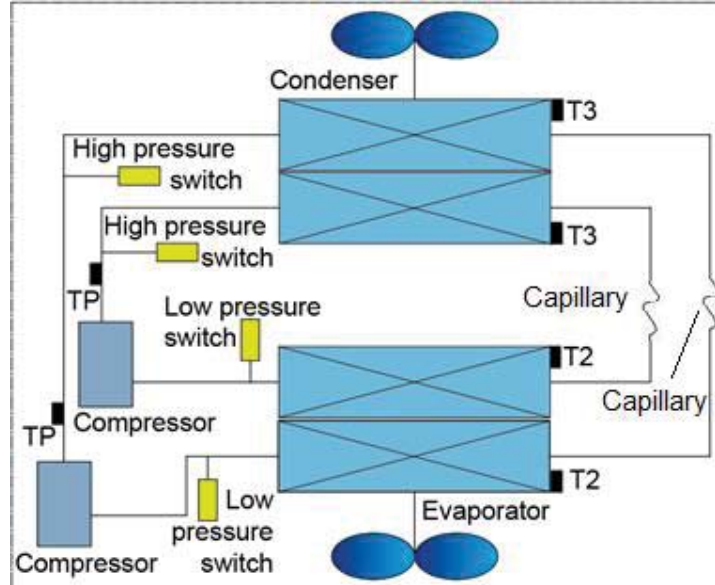

6. Duct work

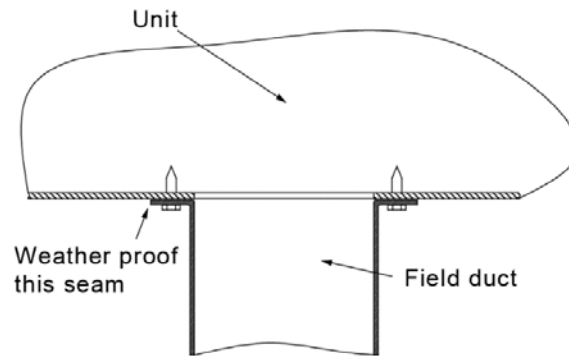

- ✧ All conditioned air ductwork should be insulated to minimize heating and cooling duct losses. Use a minimum of 2 inches of insulation with a vapor barrier. The outside ductwork must be weatherproofed between the unit and the building.
- ✧ When attaching ductwork to a horizontal unit, provide a flexible watertight connection to prevent noise transmission from the unit to the ducts. The flexible connection must be indoors and made out of heavy canvas.
- ✧ Do not draw the canvas taut between the solid ducts.
- ✧ At least 1m flame resistant layer must be laid at the end of air duct internal surface.

7. Electrical wiring

7.1 Warning

- ✧ An all-pole disconnection switch having a contact separation of at least 3mm in all poles should be connected in fixed wiring.
- ✧ The appliance shall be installed in accordance with national wiring regulations.
- ✧ An all-pole disconnection device which has at least 3mm separation distance in all pole and a residual current device (RCD) with the rating of above 10mA shall be incorporated in the fixed wiring according to the national rule.
- ✧ The appliance shall be installed in accordance with national wiring regulations.

7.2 Wiring provision

- ✧ The units are internally wired at the factory according to generally accepted electrical technology.

- ◇ Main power wiring to the unit control wiring between the control center and the unit, and earth wiring are required in the field.
- ◇ The following components are required: main power fuses; conduit coupling.
- ◇ Wire and fuse sizes should be selected in accordance with national and standard, taking the designed maximum current shall be the total of the compressor maximum current, condenser fan motor current and evaporator fan motor current.
- ◇ The wire size between the wired controller and the unit should be determined according to the following table, because the 24V power source is applied to the control circuit.

	Wiring length between wired controller and unit (One way)				
Min. wire size (mm ²)	10m	15m	20m	30m	40m
	0.5	0.5	0.75	0.75	1.0

- ◇ Main power supply parameters:

Model	Main power	Main power switch	Fuse
APRH048C7A-D	380~415V, 3Ph~, 50Hz	25A	20A
APRH060C7A-D		30A	25A
APRH075C7A-D		35A	25A
APRH090C7A-D		40A	30A
APRH105C7A-D		45A	35A
APRH120C7A-D		50A	40A
APRH150C7A-D		63A	50A
APRH180C7A-D		75A	63A
APRH210C7A-D		90A	80A
APRH240C7A-D		100A	90A
APRH300C7A-D		120A	100A
APRH360C7A-D		120A	100A

Model	Wires for power supply	Type of wires
APRH048C7A-D	3×6mm ² + 2×3mm ²	3 × UL1015 9AWG 2 × UL1015 12AWG
APRH060C7A-D	3×6mm ² + 2×3mm ²	3 × UL1015 9AWG 2 × UL1015 12AWG
APRH075C7A-D	3×6mm ² + 2×3mm ²	3 × UL1015 9AWG 2 × UL1015 12AWG
APRH090C7A-D	3×10mm ² + 2×6mm ²	3 × UL1015 7AWG 2 × UL1015 9AWG
APRH105C7A-D	3×10mm ² + 2×6mm ²	3 × UL1015 7AWG 2 × UL1015 9AWG
APRH120C7A-D	3×10mm ² + 2×6mm ²	3 × UL1015 7AWG 2 × UL1015 9AWG
APRH150C7A-D	3×16mm ² + 2×10mm ²	3 × UL1015 5AWG 2 × UL1015 7AWG
APRH180C7A-D	3×16mm ² + 2×10mm ²	3 × UL1015 5AWG 2 × UL1015 7AWG
APRH210C7A-D	3×25mm ² + 2×10mm ²	3 × UL1015 3AWG 2 × UL1015 7AWG
APRH240C7A-D	3×25mm ² + 2×10mm ²	3 × UL1015 3AWG 2 × UL1015 7AWG
APRH300C7A-D	3×35mm ² + 2×16mm ²	3 × UL1015 2AWG 2 × UL1015 5AWG
APRH360C7A-D	3×35mm ² + 2×16mm ²	3 × UL1015 2AWG 2 × UL1015 5AWG

◇ Power supply wiring diagram

APRH048, 060C7A-D:

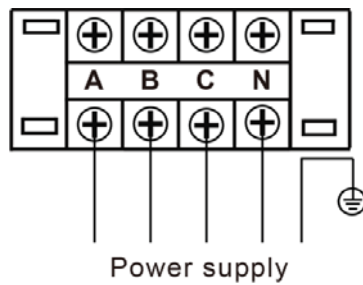

APRH075-120C7A-D

APRH150-360C7A-D

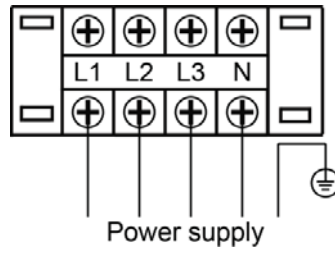

◇ Wired controller wiring diagram (Standard wired controller)

APRH048-360C7A-D

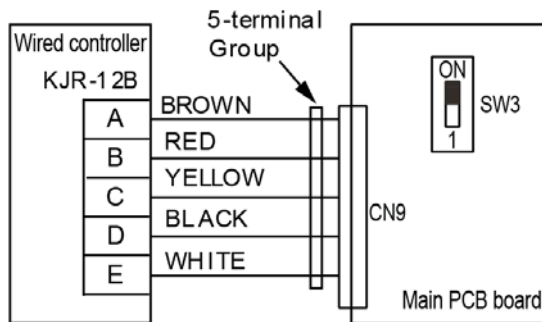

The standard wired controller model of these units is KJR-12B/dp(T)-E. When KJR-12B is connected, the switch SW3 should be set to ON.

APRH075, 090C7A-D:

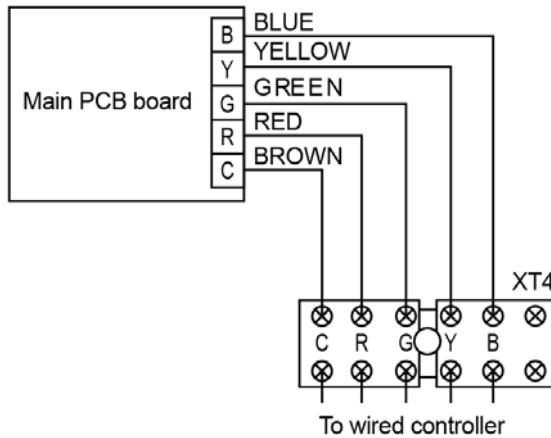

The standard wired controller model of these units is KJR-25B.

APRH105, 120C7A-D:

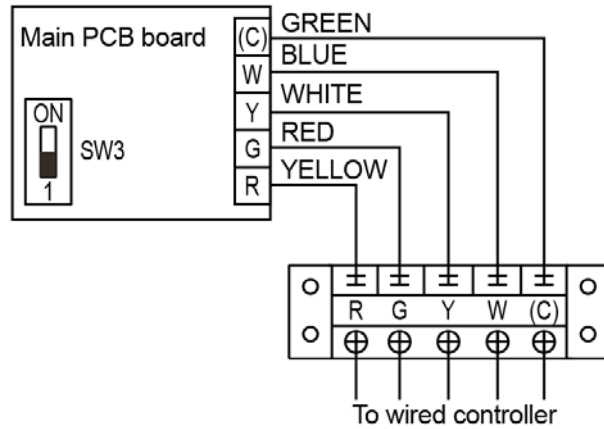

The standard wired controller model of these units is KJR-25B. When KJR-25B is connected, the switch SW3 should be set to 1.

- ◇ Wired controller wiring diagram (Optional wired controller)

APRH048, 060C7A-D:

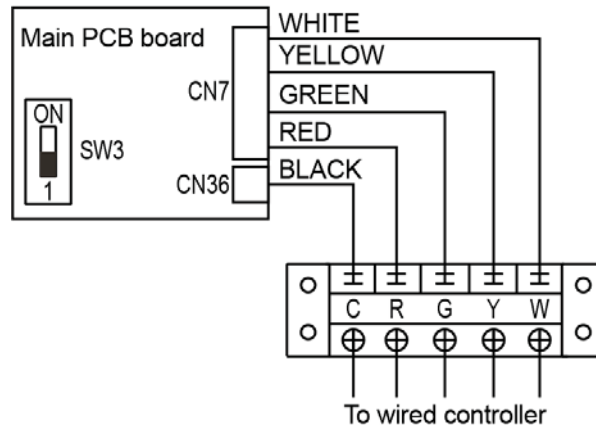

Optional wired controller of these two units is KJR-25B. When KJR-25B is connected, the switch SW3 should be set to 1. After settings, please shut off the power supply and repower again, otherwise, the new settings function could not work.

APRH075-120C7A-D

These units cannot directly connect with wired controller KJR-12B. If these units connect with KJR-12B, it should be customized to change the main PCB board of the unit.

APRH105-360C7A-D

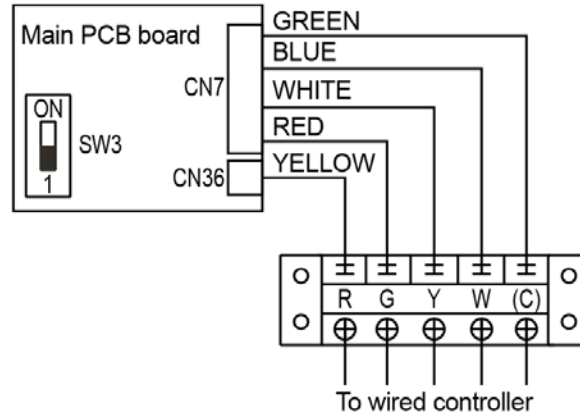

- ✧ If choose KJR-25B or Non-programmed electrical thermostat of other brand, such as Honeywell. Wiring should refer to the manual of the thermostat. After connection, set SW3 in 1. Finally, shut off the power supply and then repower.

8. Start-up

Before starting unit:

- ✧ Is the unit properly located and level with the proper clearance?
- ✧ Is the duct work correctly sized, run, taped, insulated, and weatherproofed with proper unit arrangement?
- ✧ Is the wiring properly sized and run according to the unit wiring diagram?
- ✧ Are all the wiring connections tight, including those in the unit?
- ✧ Has the unit been properly grounded and fused with the recommended fuse size?
- ✧ Has the air conditioning system been checked at the service ports for charge and leak tested if necessary?
- ✧ Does the condenser fan and indoor blower fan free without rubbing, and are they tight on the shafts?
- ✧ Are all covers and access panels in place to prevent air loss and safety hazards?

Starting the unit:

- ✧ When the unit operates under cooling mode, please check the line voltage of the unit. The

voltage should be within the range shown on the unit nameplate.

- ✧ If low voltage is encountered, check the size and the length of power supply wire from the main disconnect to the unit. The line may be undersized for the length of the run.

Shut-down the unit:

- ✧ Place the system selector in the OFF position or reset thermostat (Wired controller) at a setting above room temperature.
- ✧ Do not de-energize the main power supply disconnect except when unit is to be serviced.

9. Safety control

Functions

- ✧ Minutes delay for the compressor start-up:
At the beginning of energizing, 3-minutes delay should be taken to start the compressor. While after the stop of the compressor, 7-minutes delay should be taken to restart the compressor.
- ✧ Compressor discharge temperature protection:
When the temperature of compressor discharge is higher than 125°C (257°F), the compressor will stop. Once the temperature is lower than 90°C (194°F), the compressor can be started again.
- ✧ Reverse phase protection relay:
The reverse phase protection relay will make the unit not start, when the power supply source is in correctly conneted.
The checking of phase order is just carried out at the first time of electrifying. If malfunction happens then the checking will be going on until the order of phase is right, and the error code will be displayed on the board. If there is no problem in the first checking, then it will be omitted.
- ✧ High pressure and low pressure protection :
When high pressure is equal or higher than 638 Psi, and lower pressure is equal or lower than 21Psi, the unit will stop.

Error & protection code



APRH048-360C7A-D

Type	Content	Code	Remarks
Normal	Standby	-----	
Normal	Constraint cool	ON	
Normal	Run	10.	
Error	Compressor phase sequence error or phase lack	E0	
Error	Condenser pipe temperature sensor (T3) in system A error	E1	
Error	Condenser pipe temperature sensor (T3) in system B error	E2	
Error	Over current protection of system A's compressor is active 3 times within 1 hour	E3	Unit shall be power-off to recovery
Error	Over current protection of system B's compressor is active 3 times within 1 hour	E4	Unit shall be power-off to recovery
Error	Evaporator pipe temperature sensor (T2) in system A error	E5	
Error	Evaporator pipe temperature sensor (T2) in system B error	E6	
Error	High & low pressure protection, or high discharge temperature protection of system A reached 3 times within 1 hour.	E7	Unit shall be power-off to recovery
Error	High & low pressure protection, or high discharge temperature protection of system B reached 3 times within 1 hour.	E8	Unit shall be power-off to recovery
Error	Indoor side room temperature sensor (T1) error	E9	
Error	Ambient temperature sensor (T4) error	EA	
Error	Wired controller communication error	Eb	
Error	Eeprom error	EE	
Protection	Over-current protection of compressor in system A	P0	
Protection	Over-current protection of compressor in system B	P1	
Protection	Over-current protection of indoor side fan motor	P2	

Continued :

Type	Content	Code	Remarks
Protection	Comprehensive protection of outdoor side fan motor	P3	
Protection	Protection of high/low pressure or high temperature protection of discharge sensor in system A	P4	Comprehensive protection of system A
Protection	Protection of high/low pressure or high temperature protection of discharge sensor in system B	P5	Comprehensive protection of system B
Protection	Hi-pressure protection initiated in T2 evaporator stops the outdoor unit fan	P6	
Protection	Hi-pressure protection initiated in T2 evaporator stops the outdoor unit fan and compressor	P7	
Protection	High temperature protection of condenser in system A	P8	Power off to recovery.
Protection	High temperature protection of condenser in system B	P9	Power off to recovery.
Protection	Anti-freezing protection of evaporator in system A	Pc	
Protection	Anti-freezing protection of evaporator in system B	Pd	
Protection	Protection of outdoor ambient temperature	PA	

Notes: If same protection which includes all system for 2-stage products is triggered 3 times within 1 hour, the unit should be power-off to recovery.

✧ **APRH075-120C7A-D**

Content	LED1	LED2	LED3
	(Red)	(Yellow)	(Green)
Standby	OFF	OFF	ON
Normal operation	ON	ON	ON
Phase sequence error or phase lack	FLASH	FLASH	FLASH
Indoor side room temperature (T1) error, or high pressure protection, or high temperature protection of discharge sensor	FLASH	FLASH	FLASH
Evaporator pipe temperature sensor (T2) error	FLASH	OFF	FLASH
Condenser pipe temperature sensor (T3) error	OFF	FLASH	FLASH
Ambient temperature sensor (T4) error	ON	FLASH	FLASH
Over-current protection of compressor	OFF	OFF	FLASH

Continued:

Content	LED1	LED2	LED3
	(Red)	(Yellow)	(Green)
Low temperature protection of evaporator	OFF	FLASH	OFF
High temperature protection of evaporator	FLASH	ON	ON
High temperature protection of condenser	FLASH	OFF	OFF
Wired controller communication error	FLASH	FLASH	ON
Low pressure protection	FLASH	ON	FLASH

Phase sequence error or phase default:

Compressor sequence error or phase default:

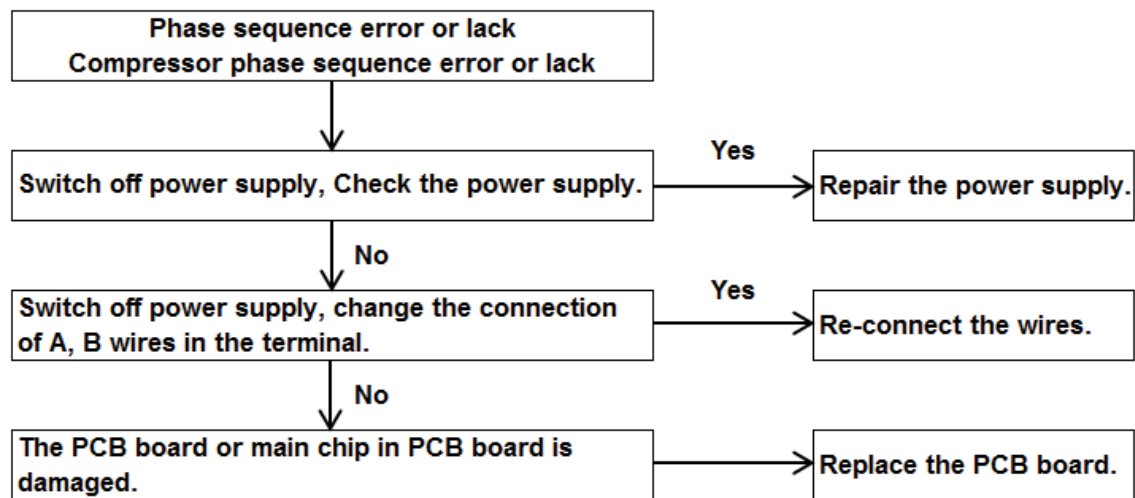

Evaporator pipe temperature sensor (T2) error:

Condenser pipe temperature sensor (T3) error :

Ambient temperature sensor (T4) error:

Indoor side room temperature sensor (T1) error :

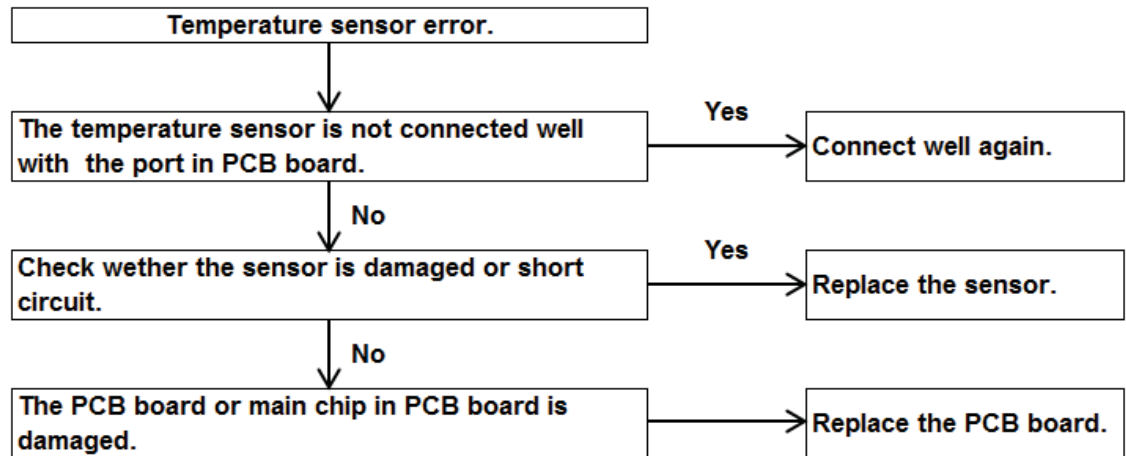

Over-current protection of compressor:

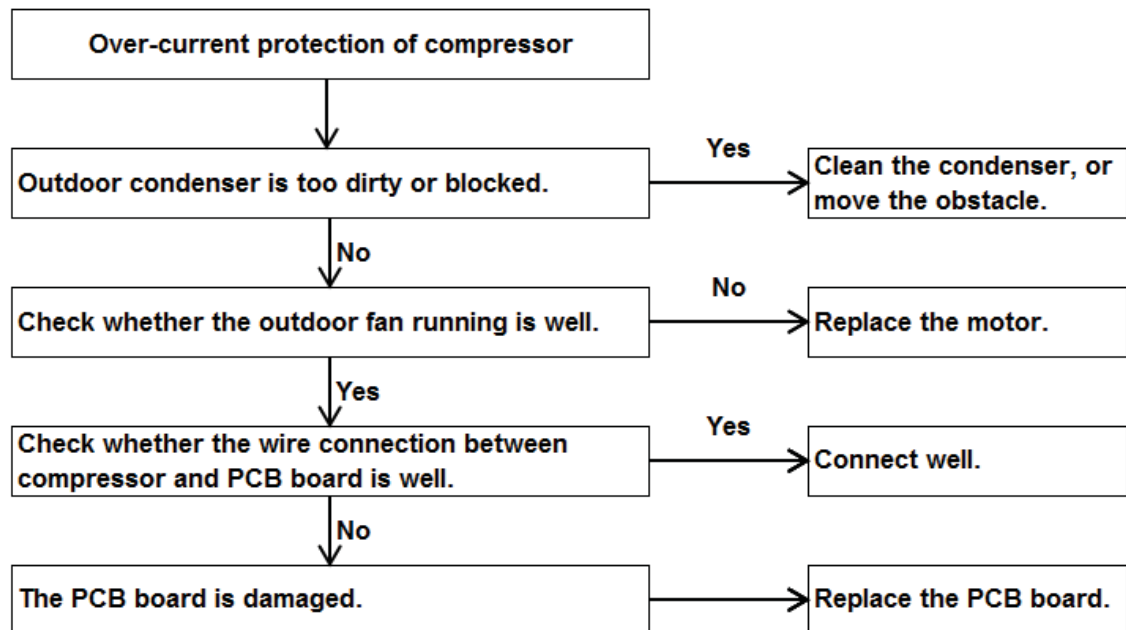

High pressure protection:

High discharge temperature protection :

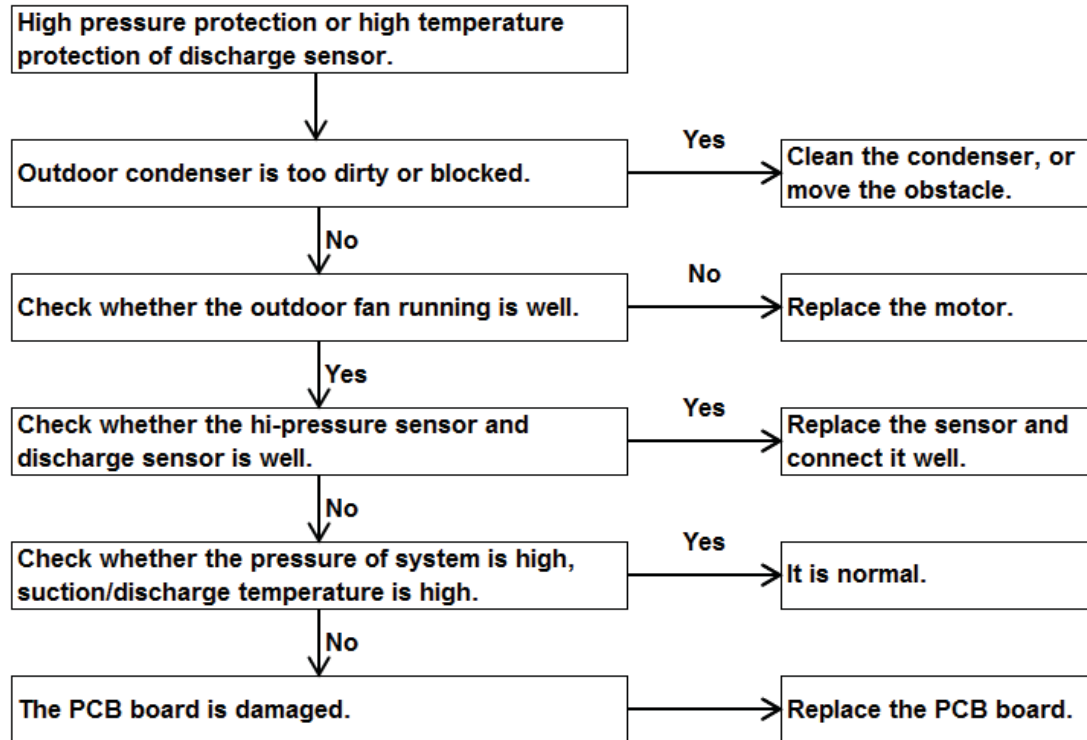

Wired controller communication error :

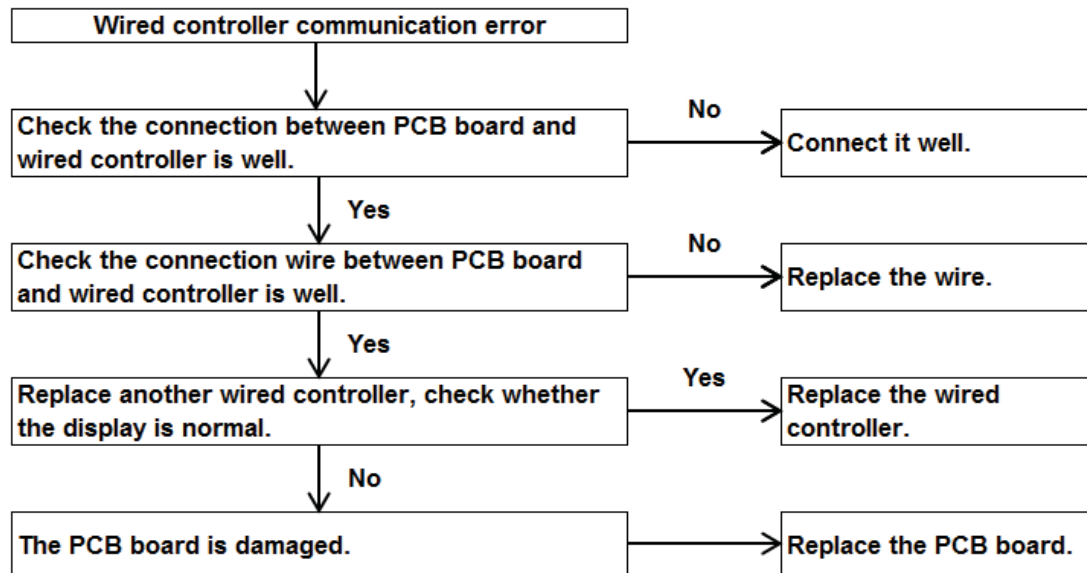

Low pressure protection :

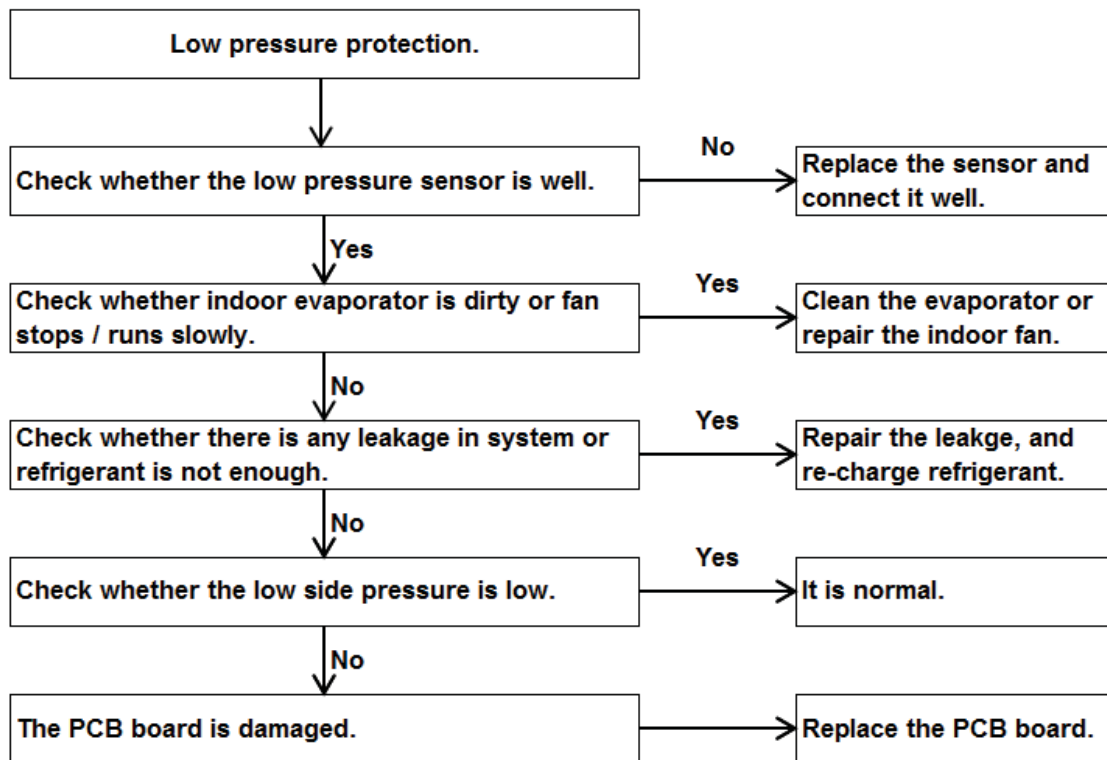

Eeprom error :

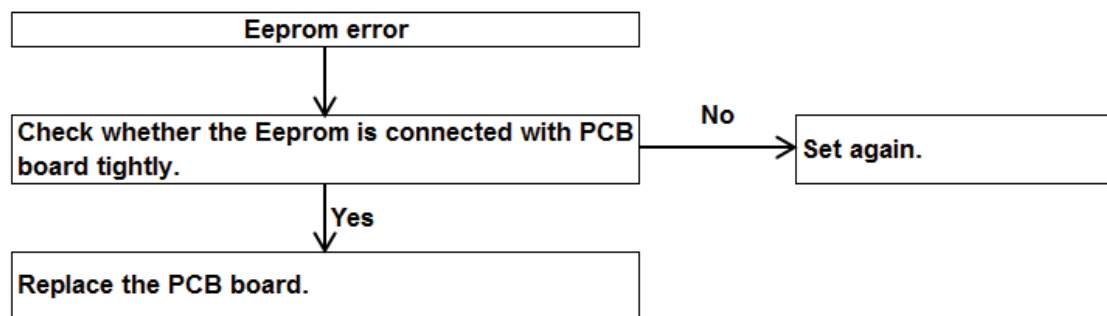

Over-current protection of indoor side fan motor :

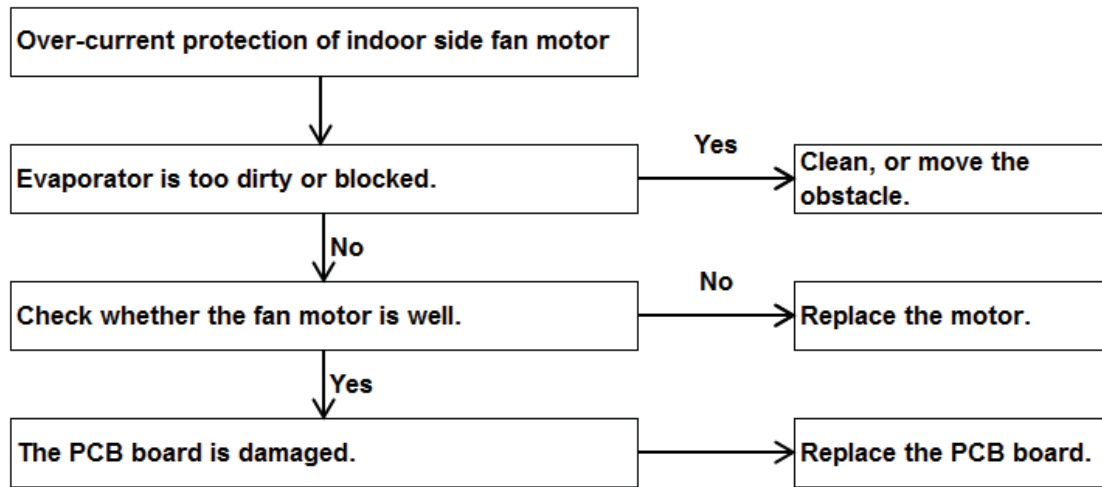

Comprehensive protection of outdoor side fan motor :

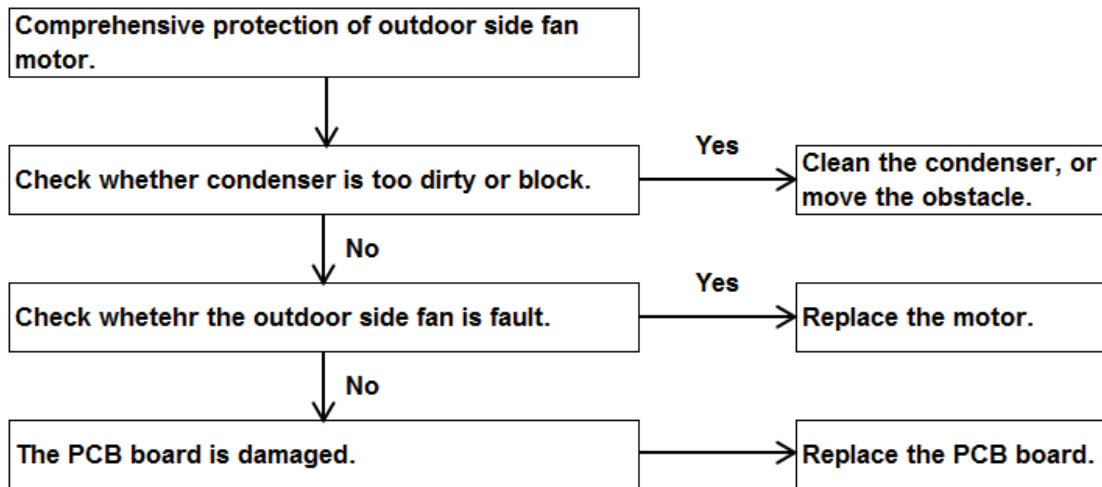

High temperature protection of condenser :

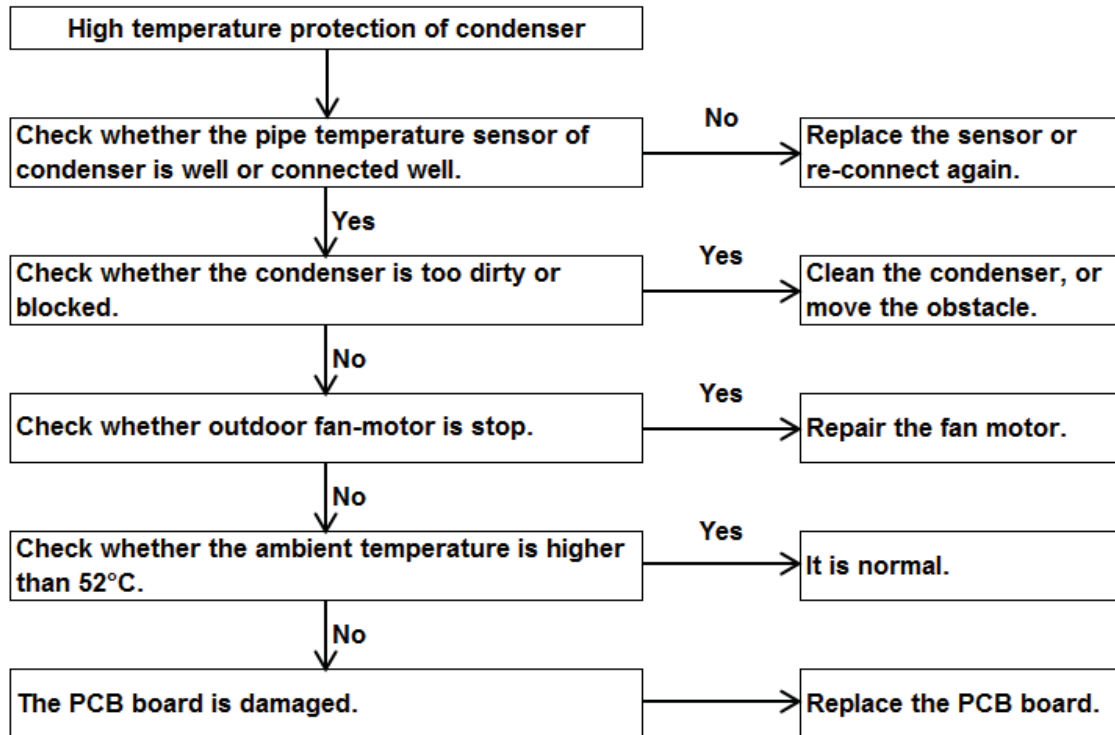

Low temperature protection of evaporator:

Anti-freezing protection of evaporator :

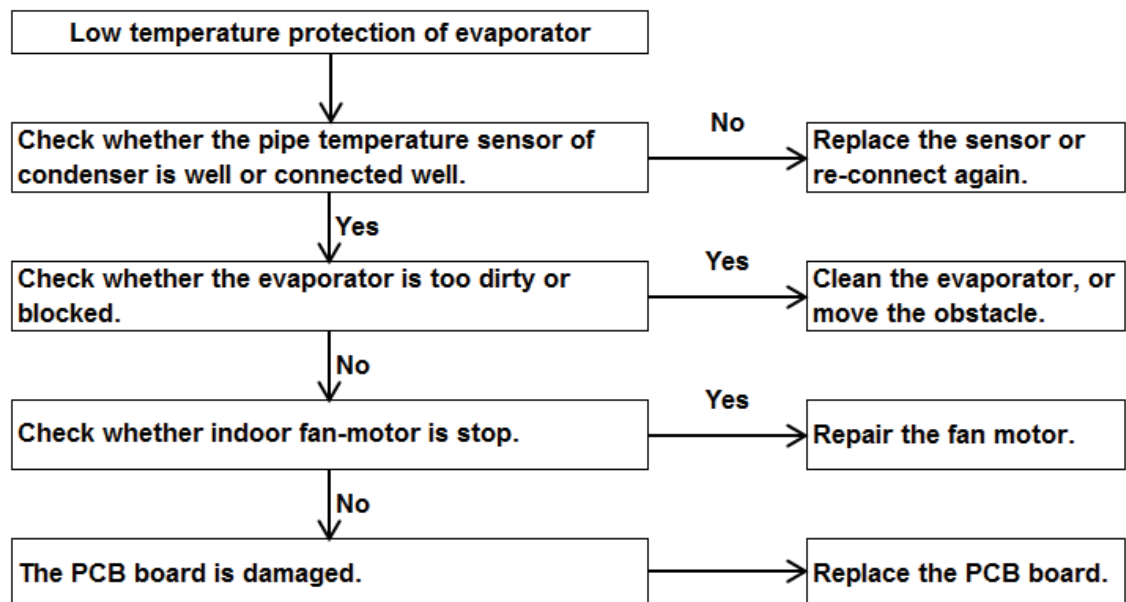

Protection of outdoor ambient temperature :

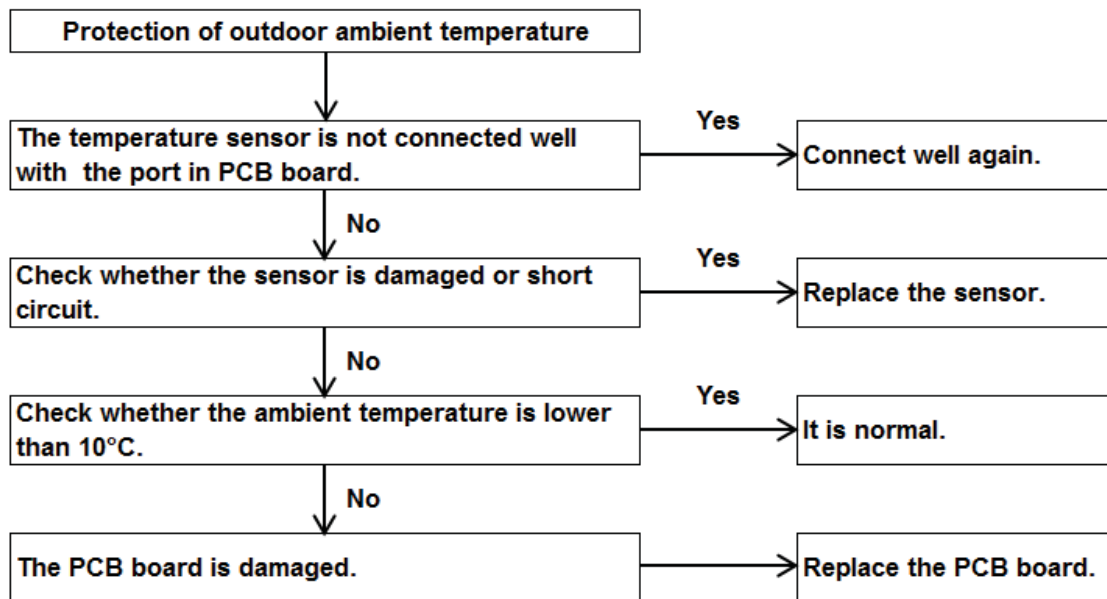

10. Maintenance

Caution

- ✧ Do not operate the unit without the evaporator fan access panel in place. Reinstall the access panel after performing any maintenance. Operating the unit without the access panel may result in severe personal injury.
- ✧ Disconnect the power supply before cleaning and maintenance.

Regular maintenance

Some regular maintenance has been carry on by user. It includes: change the one-time dust filter, clean casing, wash condenser and replace a new belt, as well as do some test for the equipment.

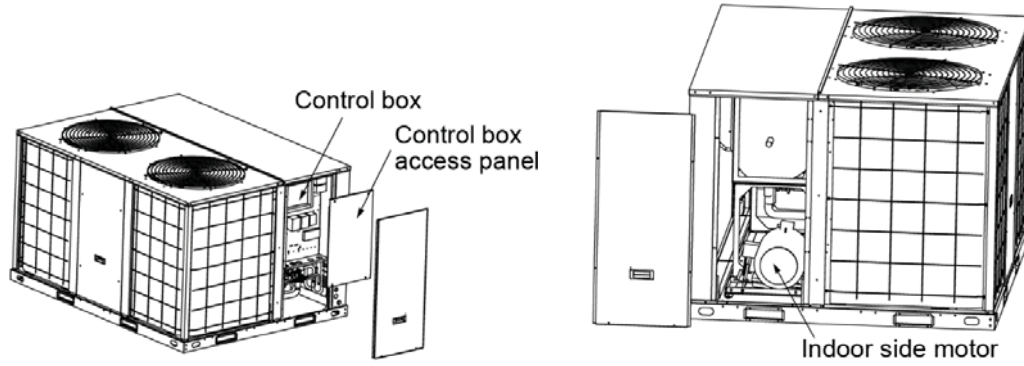

Regulating belt of tension

Refer to the following figure, loose 2 bolts, and move the electric motor to adjust belt tension. These two bolts are used for precision adjustment.

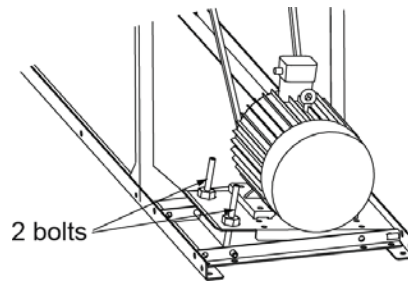

Belt tension is measured by belt tension indicator

- ◇ Calculate the deflection, deflection (L) = A/64.

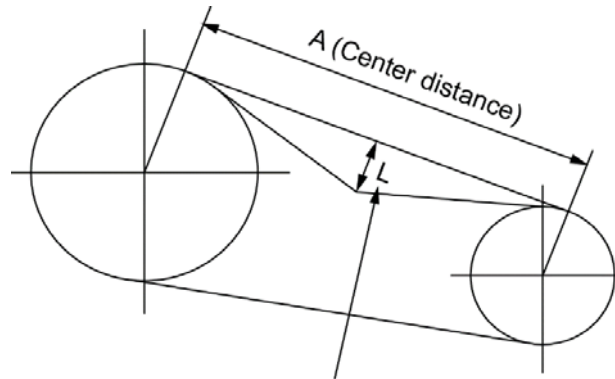

Belt tension indicator applied to middle center distance

Notes: $L=A/64$

Model	A (mm)
APRH105C7A-DD1300	380

APRH120C7A-DD1350	380
APRH150C7A-DD1440	560
APRH180C7A-DD2530	560
APRH210C7A-DD2610	580
APRH240C7A-DD2700	580
APRH300C7A-DD2870	480
APRH3607CA-DD3105	480

- ◇ Measure the belt deflection force, the force should be between the values shown in the following lists.
- ◇ The belt which is too tight or too loose may generate noise and be harmful to the unit.

Belt section	For required to deflection		
	Small pulley diameter	Newton	Kilogram-force
SPA	80mm~132mm	25N~35N	2.5kg.f~3.6kg.f

Air intake filter clean (The filter should be customized).

Step 1: Dismantle the air filter.

- ◇ Twist of screws and get out the plate.
- ◇ Pull out the filter along the supporting slot.

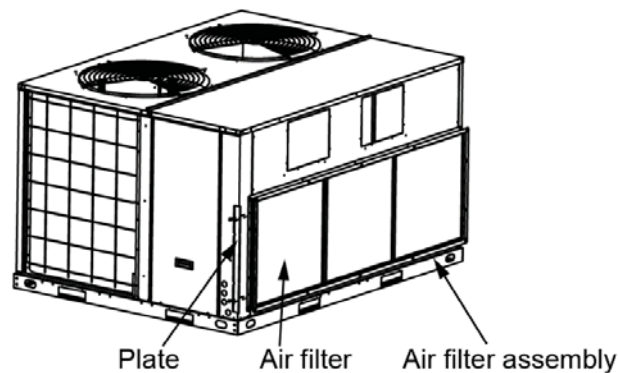

Step 2: Clean the air filter.

- ◇ Vacuum cleaner or fresh water may be used to clean the air filter. If the dust accumulated too much, please use soft brush and mild detergent to clean.
- ◇ The air-in side should face up when using vacuum cleaner.

-
- ◇ The air-in side should face down when using water.

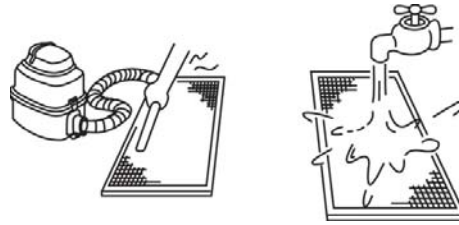

- ◇ After cleaning, please dry out in cool place. Do not dry out the air filter under direct sunshine or heat.

Step 3: Re-install the air filter.

Condenser coil

Unfiltered air circulates through the unit's condenser coil can cause the coil's surface to become clogged with dust. Clean the coil, vertically (i.e., with the fins), and stroke the coil surface with a soft brush. Be sure to keep all vegetation away from the condenser coil area.

Periodic maintenance

To keep the unit operating safety and efficiently, the entire system should be checked at least once each year. The examining the areas include:

- ✓ Filter;
- ✓ Motors and drive system components;
- ✓ Economizer gaskets (Reserved);
- ✓ Safety controls;
- ✓ Electrical components and wiring (For possible replacement and connection tightness);
- ✓ Condenser drainage (For cleaning);
- ✓ Unit duct connections (To check that they are physically sound and sealed to the unit casing);
- ✓ Unit mounting support (For structural integrity);
- ✓ The unit (For obvious unit deterioration).

Part. 2 Controller

1. Wired controller: APACT-D12	40
2. Wired Controller:APACT-D25	49
3. Centralized Controller: VAECC-D064T (Optional)	59

1. Wired controller: APACT-D12



APACT-D12

1.1 Wired controller specifications

Model	APACT-D12
Power supply	5.0V DC
Operation temperature	-15°C~43°C
Operation humidity	40%~90% RH

1.2 Introduction of indicators function

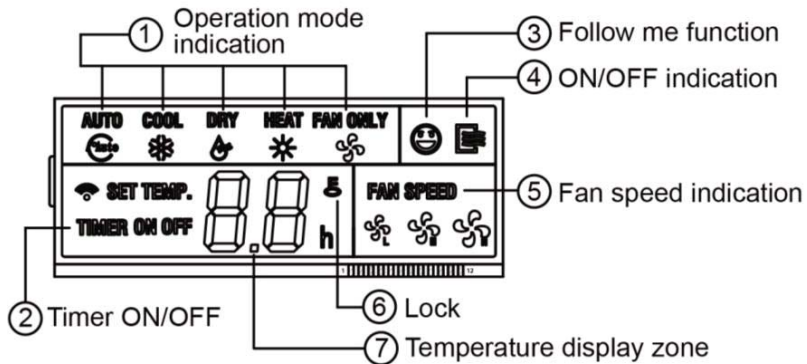

1. Operation mode indication:

When press 'MODE' button, the following mode can be selected in circle.

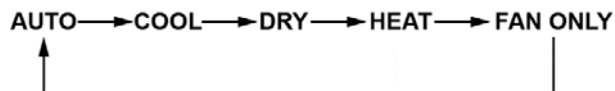

For cooling only model, the indicator '**HEAT**' is skipped.

2. Timer ON/OFF

When adjust setting on time or only on time is set, the indicator '**ON**' is lighted.

When adjust setting off time or only off time is set, the indicator '**OFF**' is lighted.

If timer-on and timer-off timer both set, the indicators '**ON**' and '**OFF**' will be both lighted.

3. Follow me function

There is a temperature sensor inside the wired controller, after setting temperature; the detected temperature by this sensor will be compared with setting temperature. The space of wired controller will be same as the setting temperature.

It is available under cooling, heating and auto mode.

4. ON/OFF indication

When it is on, the icon will be displayed, otherwise it is extinguished.

5. Fan speed indication (For rooftop packages, it is not available.)

There are four fan modes: low, medium, high and auto. For some models, there is not medium fan speed, and the medium fan speed is seen as high speed.

6. LOCK

When the '**LOCK**' button is pressed, the icon will be displayed and other button is unable.

Press the '**LOCK**' again, the icon will be extinguished.

7. Temperature display zone

Generally it displays setting temperature, it can be adjusted by press temperature button

▲ and ▼. But in fan only mode, the temperature display zone will be blank.

1.3 Introduction of buttons

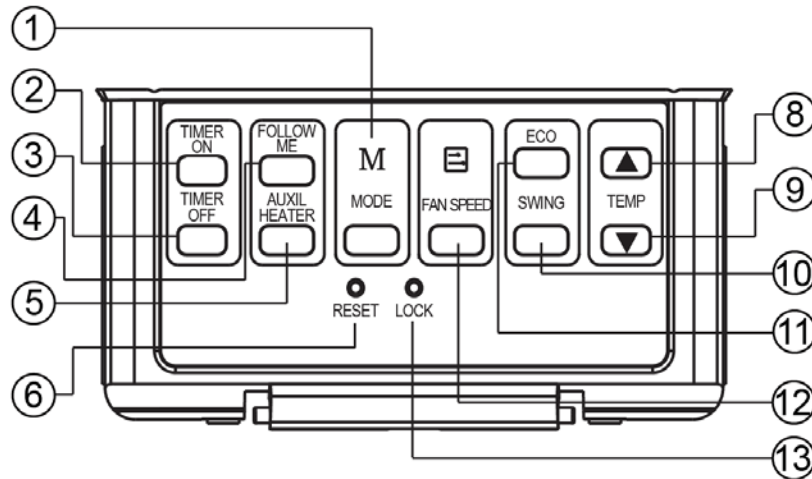
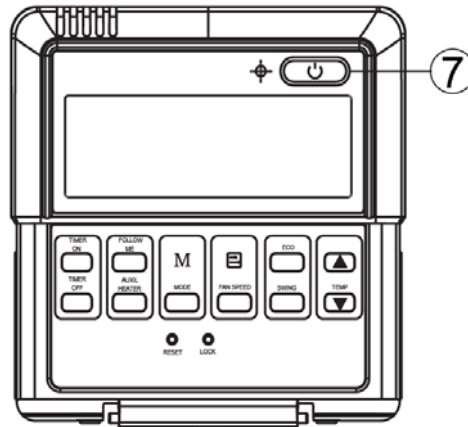

1. Mode button:

When press this button, the operation mode changes as the following sequence:

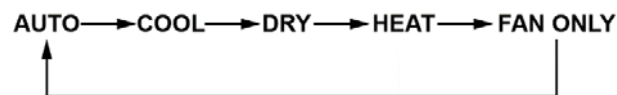

But for the cooling only model, the heating mode is skipped.

2. TIMER ON button:

Press this button, timer-on function is active. Then every press, the time will increase 0.5h, after 10 hours, increase by 1 hour for each press. If cancel this function, just set it to **0.0**.

3. Timer off button:

Press this button, timer-off function is active. Then Then every press, the time will increase

0.5h, after 10 hours, increase by 1 hour for each press. If cancel this function, just set it to

0.0

4. **FOLLOW ME** button:

When under cool, heat and auto mode, and press this button, follow me function is active.

Press again, this function is ineffective.

5. **AUXIL HEATER** button: (Only available for Cooling only with EHK model.)

If press this button in heat mode, electrical heater function become ineffective.

6. **RESET** button: (Hidden)

Use a 1 mm stick to press in the little hole, then the current setting is canceled. The wired controller enters into original state.

7. **ON/OFF** button

When in off state, press this button, the indicator is on, the wired controller enters into on state, and send setting information to main PCB board. When in on state, press this button, the indicator is off, and send instruction. If timer-on or timer-off has been set, it cancels this setting then sends instruction to stop the machine.

8. **TEMP ▲** adjust button:

Set indoor temperature up. If press and hold on, it will increase at 1°C (2°F) per 0.5 second.

9. **TEMP ▼** adjust button:

Set indoor temperature up. If press and hold on, it will decrease at 1°C (2°F) per 0.5 second.

10. **SWING** button: (Reserved)

First press, then start swing function; after second press, stop swing.

11. **ECO** button: (Economy operation, Reserved)

Press this button, and then the unit will operate in economy mode. Press again, this mode can be exited.

12. **FAN SPEED** button: (For rooftop packages, it is not available.)

When press this button consecutively, and then the indoor side fan speed will circles as following:

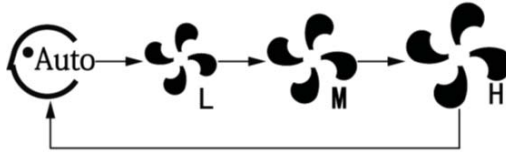

13. **LOCK** button: (Hidden)

When push the **LOCK** button, all current settings are locked in and the wired controller does not accept any instruction except that of the **LOCK** button. Use the lock mode when want to prevent setting from being changed accidentally or play fully. Push the **LOCK** button again when want to cancel the lock mode.

1.4 Operation

Automatic operation

Connect to the power supply, and the operation lamp in main PCB board will flash.

Step 1: Press **MODE** button, and select **AUTO** icon.

Step 2: Press the button ▲ and ▼, set temperature as requirement; generally it is among from 17°C to 30°C.

Step 3: Press **ON/OFF** button, operation lamp is on, the unit can be worked in auto mode, and indoor side fan speed is auto, and cannot be changed. Auto is displayed on LCD. Press it again to stop.

Notes: Economy operation is valid in auto mode.

Cool / Heat / Fan only mode operation

Step 1: Press **MODE** button, and select **COOL**, or **HEAT**, or **FAN ONLY** icon.

Step 2: Press temperature adjust button to select setting temperature.

Step 3: Press **FAN SPEED** button to select high, medium, low or auto. (For rooftop packages, it is not available.)

Step 4: Press **ON/OFF** button, indoor unit operation lamp on, it works in selected mode. Press **ON/OFF** button again, it stops to work.

Notes: In fan only mode, temperature cannot be set.

Dry operation

Step 1: Press **MODE** button, select **DRY** icon.

Step 2: Press temperature adjust button to select setting temperature.

Step 3: Press **ON/OFF** button, indoor unit operation lamp on, it works in dry mode. Press **ON/OFF** button again, it stops to work.

Notes: Under dry mode, economy operation and fan speed adjustment are ineffective.

Timer setting

The timer time is relative time, and that is delay after setting time. So when timer is set, the standard time cannot be adjusted.

Timer setting – Timer on only

Step 1: Press **TIME ON** button, it display **SET** on LCD screen, and display **H** and **ON**, it is waiting for timer on setting.

Step 2: Press **TIMER ON** button repeatedly to adjust time setting.

Step 3: If press this button and hold on, the time will increase at 0.5h, after 10 hours, it increase at 1 hour.

Step 4: After setting 0.5 second, the wired controller sends timer-on information to the unit, it is finished.

Timer setting – Timer off only

Step 1: Press **TIME OFF** button, it display **SET** on LCD screen, and display **H** and **OFF**, it is waiting for timer on setting.

Step 2: Press **TIMER OFF** button repeatedly to adjust time setting.

Step 3: If press this button and hold on, the time will increase at 0.5h, after 10 hours, it increase at 1 hour.

Step 4: After setting 0.5 second, the wired controller sends timer-on information to the unit, it is finished.

Timer-on and timer-off both

Step 1: Set timer-on time as the corresponding step 1 and step 2.

Step 2: Set timer-off time as the corresponding step 1 and step 2.

Notes: Timer-off time must be longer than timer-on time.

Step 3: 0.5 second after setting, the wired controller send information to the unit. And the setting is finished.

Change timer

When need to change timer time, press corresponding button to revise it. If cancel timer, please change timer time to **0.0**.

1.5 Installation of wired controller

Caution

- ◇ Do not install it in a place where combustible gas easily leaks. Once combustible gas leaks and remains around wired controller, fire may be cause. Do not install it in a place with oil, steam or sulphur gas, or else deform or malfunction may occur.
- ◇ Wires must be suitable for the current of the wired controller. Otherwise, electricity leakage or heating may be caused, which may result in fire.
- ◇ Install the wire joint (5P) to the appointed position of the electric controlling box.
- ◇ Circuit of wired controller is low voltage circuit, and never connected with a standard 220V or 380V circuit. Also do not put it into a same wiring tube, and the interval must be more than 300~ 500mm.
- ◇ The shield cable must be connected stable to the ground, otherwise transmission may fail.
- ◇ Wire must be suitable for wired controller, never bring outside force to bear on the terminal.
- ◇ Do not to attempt to extend the shield cable by cutting. If it is necessary, please use terminal connection block to connect.

Accessories

Item	Quantity	Remarks
Wired controller	1	\
Wood mounting screw	3	M4×20 (For mounting on the wall)
Mounting screw	3	M4×25 (For mounting on the electrical switch box)
Installation manual	1	\
Owner's manual	1	\
5P terminal group	\	\
Installation screw	\	For fixing terminal.

Preparing at site

Item	Quantity	Remarks
5-core shield cable	1	RVVP-05mm ² ×5. The longest wire is 30m.
Switch box	1	\
Wiring tube	1	Insulating sleeve and tightening screw.

Wiring principle

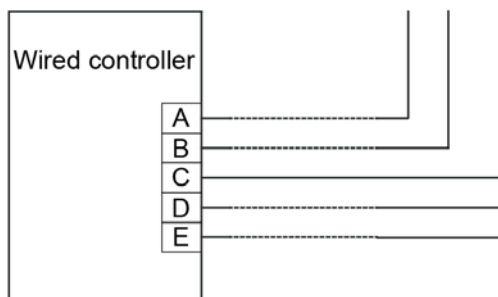

When it is necessary to use the wired controller, please follow the label of A/B/C/D/E to connect the wired controller. And the other side of the signal wire should be connected with main PCB board well. A is anode, and B is cathode. C is +5V. D is GND and E is RUN.

Installation:

Confirm the installed location of wired controller, before install the wired controller. If install it on the wall without electric switch box, the hole for 5P-terminal of wired controller is necessary.

Dimension of rear cover as following picture (Unit: mm):

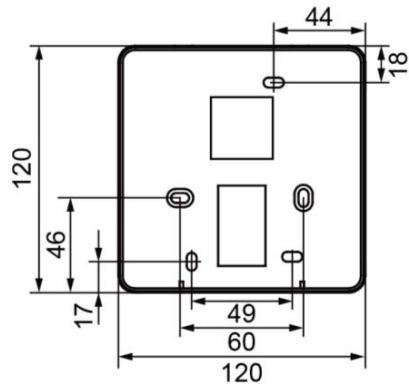

Installation figure as following:

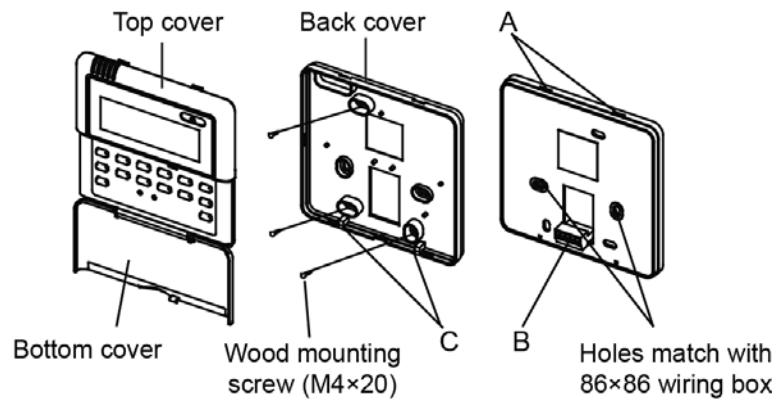

A: Turn a screwdriver at the concave on bottom panel of the wired controller to remove the back cover.

B: When installing the wired controller cover, it is sure that there is a hole in the wall to avoid the wired controller back cover being fixed directly to the wall which is not allowed for the wire joint extrudes out of the back cover.

C: When installing the wired controller, adjust the bottom of the controller board to the back cover which should be fixed first, then press the other end of the controller board.

Notes: The connecting wire should be a little longer as to take away the switch board and controller easily for maintenance.

2. Wired Controller: APACT-D25



APACT-D25

2.1 Wired controller specifications

Model	APACT-D25
Power Supply Voltage	AC 24V
Temperature display range	0°C~37°C
Temperature control range	7°C~35°C
Temperature control accuracy	±0.5°C
Sensor	NTC 1%, B=3950

2.2 Introduction of button

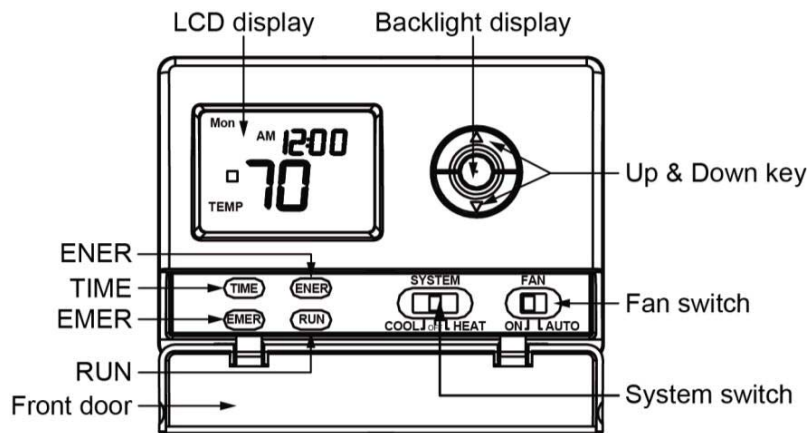

TIME:

Be used to entering time.

ENER:

Measures and displays heating and cooling system operating time for today, yesterday, this week, last week or total. By monitoring energy usage, the thermostat can be programmed to

optimize energy savings.

EMER:

It is used to select operating under EMER mode.

RUN:

Returns display to current time and temperature.

Backlight display:

This key allows users to operate the device in a dark room. The device lights up when a button is pressed, and turns off when a given operation is completed. The display will remain illuminated for 8 seconds after the last key is pressed. If the controller is in low battery warning condition, this function will not operate. Replace with 2 AA alkaline batteries to restore the function.

Up & Down key:

It is used to change the temperature setting. Also used for increasing and decreasing selections in the time, program and span functions.

Fan switch:

It is used to select automatic or continuous fan operation. It should normally be located in the **AUTO** position. The fan will be turned on along with normal operation of the unit. To run the fan on continuously, slide the FAN switch to the **ON** position.

System switch:

It can determine the operating mode of the wired controller. Select **COOL**, **OFF** and **HEAT**. Anytime you install or remove the controller from the wall plate, slide the system selector to the **OFF** position to prevent the possibility of a rapid system ON-OFF.

Front door:

Cover keys open with one finger from left or right.

2.3 Configuration

After installation and wiring connection of wired controller, it should be operated configuration first.

Set **SYSTEM** switch to **OFF**, and then press both **UP** and **DOWN** keys for 5 seconds to enter configuration menu. The display will show the first item in the configuration menu.

Press button	Displayed	Press up or down button to select	Comments
	(Factory default)		
Backlight button	MS 2	SS1	Single stage
		MS1	Multi-stage
		HP1	Heat Pump (Single stage)
		HP2	Heat Pump (2-stage)
Backlight button	(RECO)off	On	Recovery enable
		Off	Recovery disabled
Backlight button	(SPAN)2	1	Span(one stage)1
		2	Span(one stage)2
		3	Span(one stage)3
Backlight button	(BLIT)on	On	Backlight on
		Off	Backlight off
Backlight button	(SP2)2	1	Span(Two Stage) 1
		2	Span(Two Stage) 2
		3	Span(Two Stage)3
Backlight button	(TEMP)F	F	Selects temperature display °F
		C	Selects temperature display °C
Backlight button	HOUR(12)	12	Selects time format display 12hours
		24	Selects time format display 24hours
Backlight button	COMP(OFF)	OFF	Selects Compressor Lockout OFF
		ON	Selects Compressor Lockout ON
Backlight button	COOL(2)	2	This model must select 2
		1	Just use for one stage system
Backlight button	FACT(0)	0	Display normal
		1	Use for another model to go back to factory default
		2	All the setting will go back to factory default

The configuration menu allows you to set certain thermostat operating characteristics to your system or personal requirements.

The configuration menu table summarizes the configuration options. An explanation of each option follows. Press **Backlight** button to change to the next menu item.

Press **RUN** button to exit the menu and unit will return to the normal operation. If no keys are pressed within 15 seconds, the thermostat will revert to normal operation.

1) Single Stage, Multi-stage or Heat Pump System Configuration

This control can be configured for Heat Pump or two stage heat/one stage cool multi-stage operation. The display indicates **MS2** (default for multi-stage mode) in the display. The Multi-stage configuration can be toggled to **SS1** or **HP1** by pressing the up or down key. In Multi-stage configuration, EMER mode is useless.

2) Fast or Slow Cycle Selection (one stage)

3) Select Backlight function OFF or ON

4) Fast or Slow Cycle Selection (two stages)

5) Select °F or °C Readout. Changes the display readout to Centigrade or Fahrenheit as required

6) Selects time format display 12hours or 24hours

7) Select Compressor Lockout COMP OFF or ON.

Selecting **COMP ON** will cause the thermostat to wait 4 minutes before turning on the compressor if the heating and cooling system loses power. It will also wait 5 minutes minimum between cooling and heating cycles. This is intended to help protect the compressor from short cycling. Some newer compressors already have a time delay built in and do not require this feature. Your compressor manufacturer can tell you if the lockout feature is already present in their system. When the thermostat compressor time delay occurs it will flash the set point for about four minutes.

8) This model must select 1.

9) This model must select 1 to back factory Default.

2.4 Operation instructions

1) Fan operation:

Step 1: Turn on power supply to system.

Step 2: Move **FAN** switch to **ON** position. The fan of unit will begin to operate.

Step 3: Move **FAN** switch to **AUTO** position. The fan of unit will operate according to the setting of system immediately.

2) Cooling operation:

Step 1: Move **SYSTEM** switch to **COOL** position to select cool mode.

Step 2: Press to adjust the wired controller setting below room temperature. The fan of indoor side should come on immediately on high speed, followed by cold air circulation. The display should show **STG1**.

Step 3: Adjust temperature setting to 2°C below room temperature. The second stage cooling should begin to operate and display should show **STG1+2**.

Step 4: Press to adjust the temperature setting above room temperature. The cooling system should stop operating.

3) Heating operation (Only for heat pump unit):

Step 1: Move **SYSTEM** switch to heat mode. If the auxiliary heating system has a standing pilot, be sure to light it.

Step 2: Press to adjust the wired controller setting to 1°C above room temperature. The heating system should begin to operate. The display should show **STG1**. However, if the set point temperature display is flashing, the compressor lockout feature is operating.

Step 3: Adjust temperature setting to 3°C above room temperature. If the system configuration is set at **MS2**, **HP2** or **HP1**, the auxiliary heat system should begin to operate and the display should show **STG1+2**.

Step 4: Press to adjust the wired controller below room temperature. The heating system should stop operating.

4) Emergency operation (Only for heat pump unit)

EMER by passed the heat pump to use the heat source wired to terminal E on the wired controller. EMER is typically used when compressor operations is not desired, or prefer back-up heat only.

Step 1: Press **SYSTEM** switch to select heat mode, then press **EMER** key. **EMER** will show on the display.

Step 2: Press to adjust wired controller setting above room temperature. The Aux. heating system will begin to operate. The display will show **STG1**, **EMMER** to indicate that the Aux. heating system is operating.

Step 3: Adjust temperature setting to 2°C above room temperature. The auxiliary heat system should begin to operate and the display should show **STG1+2**.

Step 4: Press to adjust the wired controller below room temperature. The Aux. heating system should stop operating.

5) Day and time setting

The LCD will show this following figure information when batteries are first installed. The temperature will update after a few seconds. During time and day setting mode, the temperature displays will go blank.

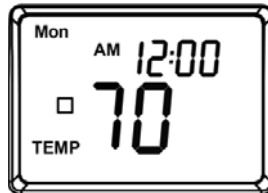

Examples: Set the wired controller to the current time of 2:16 PM on Saturday.

Step 1: Press **TIME** to enter time and day setting mode. The current hour and **AM / PM** indicator will be flashing.

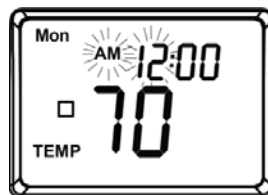

Press **UP** or **DOWN** to change the hour up or down to the current hour.

Notes: The **AM / PM** indicator, as the display will change at 12 AM and 12PM.

Step 2: Press **TIME** again to change from hour setting to minute setting. The current minute will be flashing.

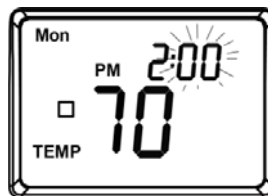

Press **UP** or **DOWN** to change the minute up or down to the current minute.

Step 3: Press **TIME** again to change from minute setting to day setting. The current days will be flashing. Press **UP** or **DOWN** to change the day up or down to the current day.

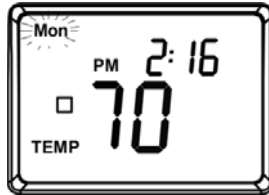

Step 4: Press **TIME** again to change back to the normal display.

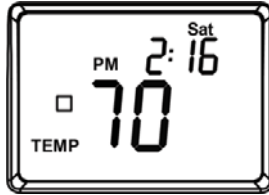

6) Reviewing the current temperature setting

Press **UP** and **DOWN** keys for less than 1 second. The setting temperature is shown above current room temperature.

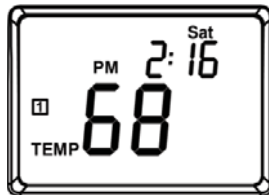

7) Energy monitor

The energy monitor feature measures and stores the amount of time the heating and air conditioning system operates. Press **ENER** key, and the usage can be display for today (Since 12 AM), yesterday, this week (Since Monday), last week (Last Monday through Sunday), and total (Up to 999 hours). By monitoring energy usage, it is easy to know how much the set-back periods are saving. To review energy usage, press **ENER** to cycle through today, yesterday, this week, last week and total. Press it again to return to normal mode, or wait 15 seconds for display to return to normal mode. Also, return to normal mode at any time by pressing **RUN**.

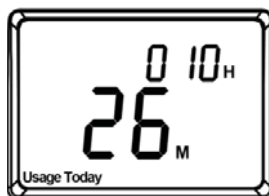

Example: this LCD display shows today's usage to be 10 hours, 26 minutes. Press **RUN** and hold for 3 seconds to reset the energy monitor's counters. The display will blink and counter will be cleared to zero.

Clearing the energy monitor counter will also clear the filter monitor counter, as filter usage and total energy usage are the same. Also, clearing the filter monitor counter will clear all energy monitor counters as well.

8) Filter monitor

This controller also keeps a record of the number of hours filter has been in use. To maximize unit's performance and energy efficiency, changing or clearing filter regularly is necessary.



When the total system run-time for heat and cool reaches 500 hours, the filter is needed to clean or change, and the FILT will continue to flash until the counter is set back to zero.

Press **ENER** to review total filter usage. The display will blink FILT. Then show the filter monitor counter. After 15 seconds, the display will return to normal mode, or press **RUN** to exit immediately.

The filter monitor will display up to 999 hours and 59 minutes of usage. In this example, the counter is at 410 hours and 26 minutes.

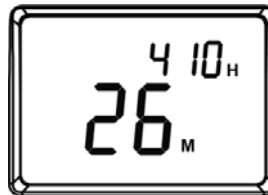

9) Keyboard lock

The keyboard can be locked to prevent unauthorized changes to the controller. To lock or unlock the keyboard, press and hold **RUN** key for 3 seconds. The keyboard is locked. When **LOCK** appears on the display, all keys are locked, and any time a key is pressed, **LOCK** will appear on the display for 1 second.

10) Low battery warning

The controller has a two-stage lower battery warning system. When the batteries are first detected to be weak, the first stage low battery warning is indicated by **BATT** flashing on the LCD display. At earliest convenience, the batteries with 2 new AA alkaline batteries should be replaced.

When the batteries become too weak for normal operation, the controller enters the second stage low battery warning which shuts down the controller. In this condition, **BATT** flashes alone on the display screen and the thermostat will turn unit off. The unit will remain shut-off until the batteries are replaced.

The controller will still keep the current set temperature and filter run-time in memory until new batteries are installed. After confirming that new batteries have been inserted, the controller will return to normal operation.

2.5 Installation of wired controller

Caution:

- ✧ This controller cannot connect with 110/220 and 380V power.
- ✧ To prevent electrical shock and / or unit damage, disconnect electric power to unit at main fuse or circuit breaker box until installation is complete.

Electric / gas switch:

This controller is configured from the factory to operate a heat/ cool, fossil fuel (gas, oil, etc.), forced-air system. It is configured correctly for any system that DOES NOT requires the controller to energize the fan on a call for heat.

If the system is an electric heat or heat-pump system that requires the controller to turn on the fan on a call for heat, locate the **ELEC/GAS** switch on the back of the controller and switch it to the **ELEC** position.

This will allow the controller to energize the fan immediately on a call for heat. If it is unsure if the heating/ cooling system requires the thermostat to control the fan, contact a qualified heating and air conditioning service person. When the controller is configured for heat pump, the controller will always power the circulator fan on a call for heat in the heat mode. The **ELEC/GAS** switch must be set to match the type of auxiliary heat system uses for proper operation in the emergency mode.

All wiring diagrams are for typical systems only.

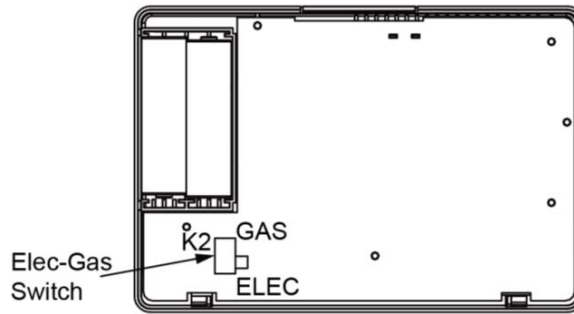

Installation:

Step 1: Remove the packing material from the controller. Gently pull the cover straight off the base. Forcing or prying on the controller will cause damage to the unit.

Step 2: Connect wires beneath terminal screws on base using appropriate wiring schematic.

Notes: The default setting value of the reminding function is 2,500 hours, and it can change to be 5,000 hours or 10,000 hours. The setting methods refer to the part of wired controller initial parameter setting.

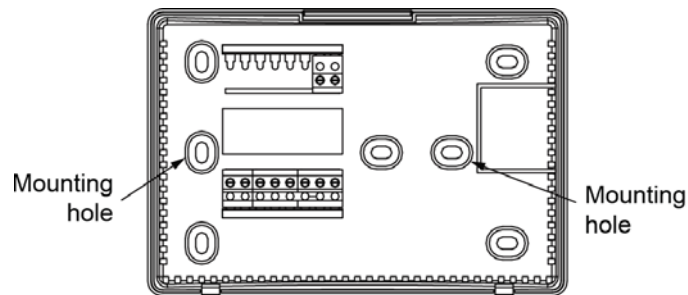

Step 3: Place base over hole in wall and mark the locations of mounting hole on wall using base as a template.

Step 4: Move base out of the way. Drill mounting holes.

Step 5: Fasten base loosely to wall, using two mounting screws. Place a level against bottom of base, adjust until level, and then tighten screws. Leveling is for appearance only and will not affect the controller operation. If using existing mounting holes, or if holes drilled are too large and do not allow to tighten base snugly, use plastic screw anchors to secure sub-base.

Step 6: Push excess wire into wall and plug hole with a fire-resistant material (such as fiberglass insulation) to prevent drafts from affecting controller operation.

3. Centralized Controller: VAECC-D064T (Optional)



Notes: For some model, the products with factory default cannot be connected with centralized controller.

3.1 Centralized controller specifications

Model	VAECC-D064T
Power Supply Voltage	220~240V 50Hz 1Ph
Ambient Temperature Range	-15°C~43°C
Ambient Humidity Range	RH40%~RH90%

Performance Features

1. System composition, centralized control.
2. Keywords and general function description.
3. Technical indices and requirements.
4. Indoor unit working status display.
5. Locking remote controller, locking keyboard of centralized controller and locking running mode.

3.2 Keypad of centralized controller



1) LOCK: In the mode setting mode, press the lock key, and the remote controller of the currently selected air conditioner will be locked or unlocked. The operation mode is: If the single-machine setting is selected, the operation is performed for the air conditioner of the current address only. If the remote controller of the air conditioner is locked currently, issue the lock command; otherwise, send the lock command. If the single-machine mode is not selected, and the remote controller of one or more currently selected air conditioners is locked, issue the unlock command; if the remote controllers of all currently selected air conditioners are in the non-locked status, issue the remote controller lock command.

When the remote controller of the air conditioner is locked, the air conditioner does not receive remote control signals from the remote controller or wired controller until the remote controller is unlocked. Press THE **QUERY** key and then press the **LOCK** key, and the keys of the centralized controller will be locked or unlocked. If the keys are currently locked, press the **LOCK** and ▲ keys concurrently again, and the keys will be unlocked; if the keys are currently unlocked, press the **LOCK** and ▲ keys concurrently, and the keys will be locked. If the keys are locked, pressing any key will be ineffective, except unlock operation. In the unified setting page, press the ▲ key and the **LOCK** key concurrently to lock all air conditioner modules in the network. The mode locking is cancelled when the key is pressed again.

Note: When locking or cancelling lock, the corresponding icon indication appears or disappears only after all the attached air conditioners are set completely, so it takes a time period. When there are many attached air conditioners, please wait patiently.

2) OK: In the setting page, press it to send the currently selected mode status and the auxiliary function status to the selected air conditioner, and display the mode setting operation results. After select the operation mode and auxiliary function status information of the air conditioner, if do not press the **OK** key, the selected information will not be sent to the air conditioner, and will not affect the current operation of the air conditioner.

The operations of remote controller locking and unlocking need no pressing of the **OK** key. The command information is sent directly after the **LOCK** key is pressed.

3) SET: In other display mode, press this key to enter the setting mode. By default, it is single

setting, and the first in-service air conditioner is displayed. In setting operation mode, press the key again, and the operation will be performed for all air conditioners in the network. Press it repeatedly to shift between single setting and global setting.



- 4) **QUERY:** Any time when pressing the key, the selected operation mode is to query the operation status of the air conditioner. By default, the first in-service air conditioner will be queried. Through the **ADD** and **REDUCE** keys, the parameter page can be changed to be queried. Through the ▲, ▼, ◀ and ▶ keys, the query status of other air conditioners can be changed.
- 5) ▲: In the query mode, every time when pressing the key, the operation status data of the air conditioner corresponding to the previous row of the matrix will be displayed. If it is currently in the first row, press the key, and the data of the air conditioner corresponding to the last row will be displayed. If this key was held down, the row will decrease one by one. In the setting mode, every time when press the key, if it is in the single operation mode, the air conditioner corresponding to the last row will be selected. If it is in the global operation mode, no effect will result after the key is pressed. In the main page, press the key to enter the query mode. By default, it is the first in-service air conditioner.
- 6) ▼: In the query mode, every time when pressing the key, the operation status data of the air conditioner corresponding to the next row of the matrix will be displayed. If it is currently in the last row, press the key, and the data of the air conditioner corresponding to the first row will be displayed. If this key was held down, the row will increase one by one. In the setting mode, every time when press the key, if it is in the single operation mode, the air conditioner corresponding to the last row will be selected. If it is in the global operation mode, no effect will result after the key is pressed. In the main page, press the key to enter the query mode. By default, it is the first in-service air conditioner.
- 7) ◀: In the query mode, every time when pressing the key, the operation status data of the previous air conditioner will be displayed. If it is currently on the first machine, press it again, and the data of the last machine will be displayed. If this key was held down, the address will decrease one by one. In the setting mode, every time when pressing the key, if it is in

single operation mode, the air conditioner of previous in-service address number will be selected. If it is in the global operation mode, no effect will result after the key is pressed. In the main page, press it to enter the query mode. By default, it is the first in-service air conditioner.

8) ►: In the query mode, every time when pressing the key, the operation status data of the last air conditioner will be displayed. If it is currently on the last machine, press it again, and the data of the first machine will be displayed. If this key was held down, the address will increase one by one. In the setting mode, every time when pressing the key, if it is in single operation mode, the air conditioner of previous in-service address number will be selected. If it is in the global operation mode, no effect will result after the key is pressed. In the main page, press it to enter the query mode. By default, it is the first in-service air conditioner.

9) ADD: In the main page or the query mode, every time when pressing the key, the data of the current page will be displayed. If it is now in the last page, press the key again, and the first page will be displayed. In the setting mode, every time when pressing the key, if it is in the temperature regulation mode, the set temperature will decrease by 1°C (or 2°C) until the highest allowed set temperature. If it is in the timing startup/shutdown time setting mode, select the upper-level set time, if no time is set, 0.0 will be displayed, if hold down the key, the upper-level data will be selected consecutively. The specific change mode is as follows:

0.0→0.5→1.0→1.5→2.0→2.5→3.0→3.5→4.0→4.5→5.0→5.5→6.0→6.5→7.0
→7.5→8.0→8.5→9.0→9.5→10→11→12→13→14→15→16→17→18→19
→20→21→22→23→24

10) REDUCE: In the main page or the query mode, every time when pressing the key, the data of the current page will be displayed. If it is now in the first page, press the key again, and the last page will be displayed. In the setting mode, every time when pressing the key, if it is in the temperature regulation mode, the set temperature will decrease by 1°C (or 2°C) until the lowest allowed set temperature. If it is in the timing startup/shutdown time setting mode, select the upper-level set time, if no time is set, 0.0 will be displayed, if hold down the key, the upper-level data will be selected consecutively. The specific change mode is as follows:

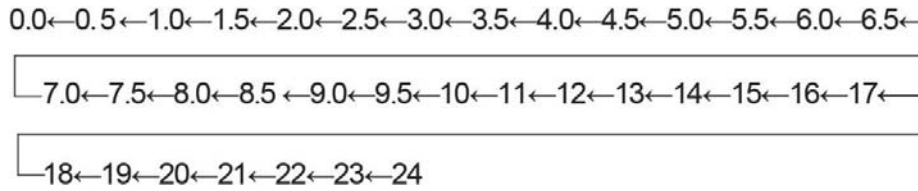

11) MODE: In setting operation mode, press this key to set the operation.

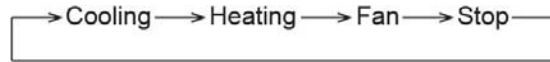

In other display mode, press this key to enter the setting mode. By default, it is single-machine setting, and the first in-service air conditioner is displayed.

12) FAN: In setting operation mode, press this key to set the fan of the indoor unit of the air conditioner to run in the following picture: (For rooftop packages, it is not available.)

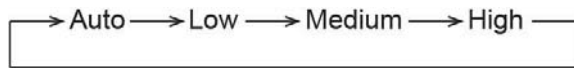

13) TIME ON/TIME OFF: In setting operation mode, press them to set the timing startup of air conditioner. Press them again to exit the timing setting, and restore the normal temperature regulation operation mode.

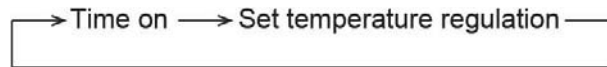

14) SWING: In the setting operation mode, press this key to enable or disable the swing function.

If all currently selected air conditioner have no swing function, no effect will result after pressing the key. (For rooftop packages, it is not available.)

15) RESET: Anytime when the **RESET** key is pressed, the centralized controller will reset. The result is the same as the result of restoring power-on after power failure.

16) ON/OFF: Any time when pressing the key, the centralized startup/shutdown operation is performed for all current in-service air conditioners in the centralized controller network. If all in-service air conditioners in the network are in the power-off status, press the key to perform the startup operation. If it is in the mode setting page currently, and the parameters such as startup mode, temperature and air speed are selected, the air conditioner will be started according to the selected parameters. If no mode is selected currently, and the air conditioner is powered off or it is in other display page currently, and the default startup mode is: cooling, high speed fan air, set temperature 24°C, swing function enabled. The default startup mode is locked according to the system mode or judged according to other

constraint conditions. If any conflict exists, the next conflict-free mode will apply automatically. If conflict exists for all modes, startup will be impossible. If one or more in-service air conditioners in the network (including in the timing process of timing startup/shutdown), pressing this key will shut down all air conditioners. When performing the shutdown operation, the shutdown command is issued to the air conditioners in the startup status only, and is not issued to those in the shutdown status.

3.3 Display of the centralized controller

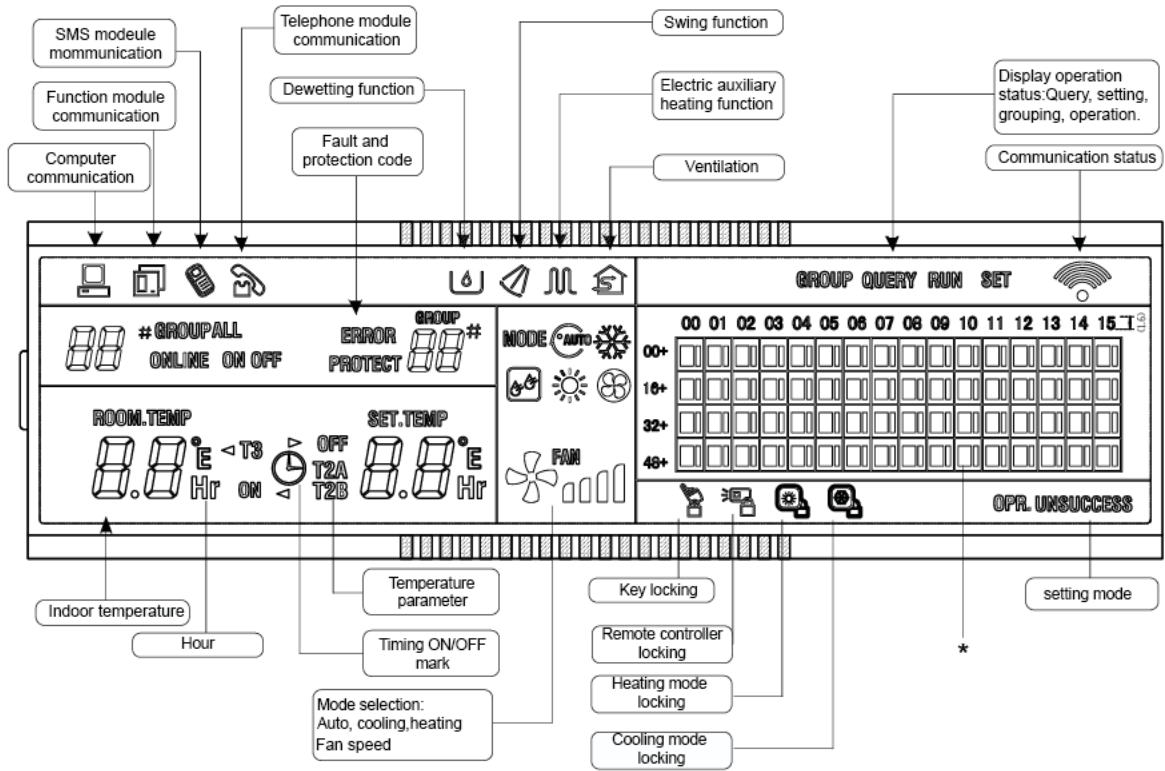

*: The matrix is composed of 4×16 grids and each grid is composed of two blocks of different sizes. The matrix include horizontal coordinates 00-15 and vertical coordinates 00+, 16+, 32+ and 48+, which indicate the address of the indoor unit. The sum of the horizontal coordinate and vertical coordinate of the grid is the address of the grid. Each grid corresponds to an indoor unit of this address.

3.4 Operation instructions

1) System composition:

- ✓ The centralized controller is used to perform centralized control and data query for the network air conditioner. Each centralized controller can communicate with a maximum of 64 air conditioners to make up an air conditioner LAN, and implement centralized monitoring for the air conditioners in the network.
- ✓ The centralized controller can be interfaced with computer or gateway to implement centralized control and status query for all air conditioners in the network. It can be connected with WAN via computer or gateway to implement remote computerized control (with support of computer software). Each local computer or gateway can be connected to 16 centralized controllers as a maximum.
- ✓ The master or slave answer mode is implemented for communication between the centralized controller and the air conditioner, between the computer and the centralized controller. In the LAN composed of centralized controller and air conditioner, the centralized controller is a master, and the air conditioner is a slave. In the LAN composed of computer and centralized controller, the computer or gateway is a master, and the centralized controller is a slave.
- ✓ The schematic diagram of network control system composition of air conditioner:

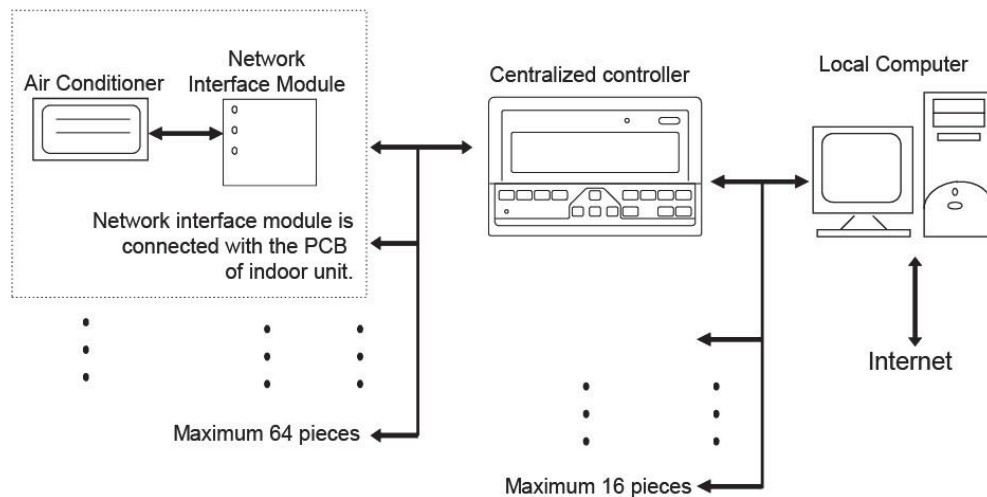

2) Keywords and general function description:

✓ Power on or reset:

When the centralized controller is powered on or reset, all display segments of the LCD are luminous for 2 seconds and then goes off. 1 second later, the system enters the normal display status. The centralized controller is in the main page display status and displays the first page, and searches the in-service air conditioners in the network. Once the search is finished, the centralized controller enters the mode setting page, and sets the first in-service air conditioner by default.

✓ Network area address of centralized controller:

The local computer or gateway can be connected with 16 centralized controllers for communication. Each centralized controller serves as an area of the air conditioner network. The centralized controllers are differentiated by bit selection address. The configurable range is 0~15.

✓ State indication:

If any local keypad operation is setting the operation status of the air conditioner, the indicator is on when the signals are sent. Upon completion of the setting process, the indicator goes off. If an in-service air conditioner in the network is faulty, or the centralized controller network itself is faulty, the indicator will blink at 2Hz.

If one or more in-service air conditioners in the network are running, including under setting of timing start or shutdown, the indicator will be luminous. Otherwise, the indicator is off.

✓ Locking of centralized controller:

After receiving the centralized controller locking command sent from the computer, the centralized controller disables the startup or shutdown and setting of the air conditioner, and sends commands to lock remote controllers of all air conditioners in the network of the centralized controller. After receiving the unlocking command, the centralized controller enables the startup or shutdown operation, and sends commands to unlock the remote controller of all air conditioners.

The locking status of the remote controller can be locked or unlocked by the computer or centralized controller separately. The locking status of the centralized controller is

memorized after power failure of the centralized controller, and will not vanish after the power supply is restored, unless the command of unlocking is received.

✓ Mode locking function:

After the mode locking command is received, the command is forwarded to the air conditioner, and the centralized controller displays the mode locking flag. After the command of unlocking is received, the non-conflict mode can be selected freely. The centralized controller can also lock modes of all indoor units.







✓ Emergent shutdown and compulsory startup:

If the emergent switch of the centralized controller was switch off, all air conditioners in the network of the centralized controller will be shut down compulsorily. The centralized controller and computer and all functional modules are disabled from startup and shutdown until the foregoing switch is turned off. If the switch was turned on, all air conditioners in the network of the centralized controller will be start up compulsorily. By default, they will run in the cooling mode. The startup and shut-down operations of the centralized controller and the computer and all functional modules will be disabled (Only the command of startup is sent to the air conditioner, without affecting operation of the remote controller after startup) until the foregoing switch is turned off. If the foregoing two switches are turned on concurrently, the emergent shutdown switch shall have preference.

3.5 General display data entries

1) General display data is displayed in all display pages.

- ✓ Under the interconnected control of the computer or gateway, the data is displayed in graphic (🖥️). Otherwise, no data is displayed.
- ✓ If the centralized controller is connected with the functional module for communication, the data is displayed in graphics (📺). Otherwise, no data is displayed.
- ✓ If the centralized controller is connected with the SMS remote control module for communication, the data is displayed in graphics (📱). Otherwise, no data is displayed.
- ✓ If the centralized controller is connected with the telephone remote control module for communication, the data is displayed in graphics (☎️). Otherwise, no data is displayed.

- ✓ In normal operation of the centralized controller, the periodical cycle module communicates with the network interface module, and the data is displayed dynamically and cyclically: (blank), , , .
- ✓ In the centralized control locked status or the keypad locked status, the locking flag () is displayed. After unlocking, it is not displayed. In the centralized controller locked status or the keypad locked status, the locking flag is displayed constantly. If both of them are locked concurrently, the locking flag is displayed constantly.
- ✓ In the setting page, if the selected air conditioner is in the remote controller locked status (in case of non-single machine operation, as long as one machine is in the remote controller locked status, it is deemed the locked status), the flag () is displayed constantly.
- ✓ If all indoor units lock the cooling mode, this flag () will display, and if all indoor units lock the heating mode, the flag () will display.

2) Data display handling

- ✓ Indoor unit code (address) display: display range: 00~63, and with # being luminous concurrently.
- ✓ Indoor temperature display: display range: 00~99°C. The indoor temperature is displayed concurrently. If the temperature is higher than 99°C, 99°C will be displayed. If the temperature value is invalid, '--' will be displayed.
- ✓ If timing startup or shutdown is set, the flag () is displayed.
- ✓ T3, T2A and T2B display: in the single-machine query page, display can shift between T3, T2A and T2B; by the way, the temperature value is displayed concurrently, with the corresponding °C being luminous.
- ✓ In case of air conditioner fault or protection, the corresponding fault code or protection, the corresponding fault code or protection code can be displayed.
- ✓ Liquid crystal matrix display description:

	00	01	02	03	04	05	06	07	08	09	10	11	12	13	14	15
00+																
16+																
32+																
48+																

The liquid crystal matrix is composed of 4×16 grids, and each grid is composed of two blocks of different sizes. The matrix includes horizontal coordinates 00~15 on the upper side and vertical coordinates 00+, 16+, 32+ and 48+ on the left side, which indicate the address of the indoor unit. The sum of the horizontal coordinate and the vertical coordinate of the grid is the address of the grid. Each grid corresponds to an indoor unit of this address. One grid is composed of two blocks of different sizes. The status indication table is as follows;

	Constantly on	Slow blink		Fast blink
Big black block	In-service	Selected		Out of service
Small black block	Power on		Fault of indoor or outdoor unit	Power off

3) LCD display description

✓ Description of the standby page

The LCD displays the standby page, 60 air conditioners are in service, of which 28 are powered on and 32 off.

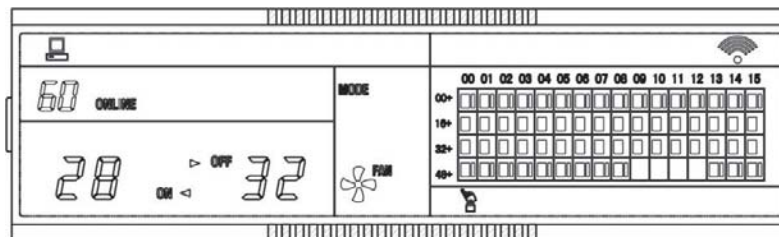

In the matrix, the big dots from (00, 16+) to (15, 32+) are luminous, and the small dots are not luminous. It indicates the 32 air conditioners with the addresses from 16 to 47 are powered off.

In the matrix, the big and small dots from (09, 48+) to (12, 48+) are not luminous. It indicates the four air conditioners with the address from 57 to 60 are outside the network.

All other big and small dots in the matrix are luminous. It indicates all other air conditioners are in the network and powered on.

The address of the air conditioner is sum of the coordinates. For example, the address of (09, 48+) is 09+48=57.

The centralized controller keypad is locked, and the centralized controller communicates with the computer normally.

- ✓ Description of the query page

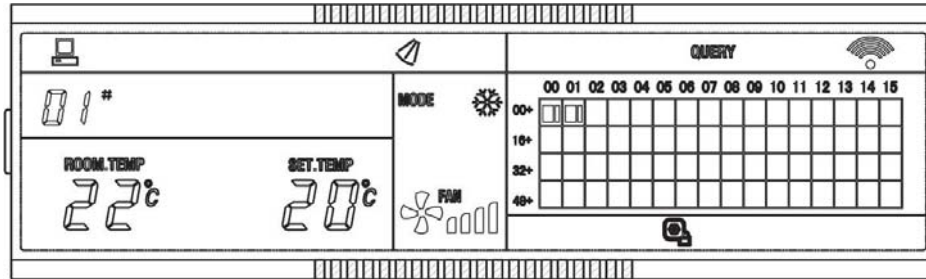

The LCD displays the query page, and the air conditioner with the address of 08 is being queried. Mode of the air conditioner with the address 01 is cooling, high speed air supply, swing on, indoor temperature 22°C, setting temperature 20°C and cooling mode locked.

In the matrix, only the big and small black dots at (00, 00+) and (01, 00+) are luminous. It indicates the in-service and power-on status of the air conditioners with the addresses of 00 and 01.

The centralized controller communicates with the computer normally.

- ✓ Description of the setting page

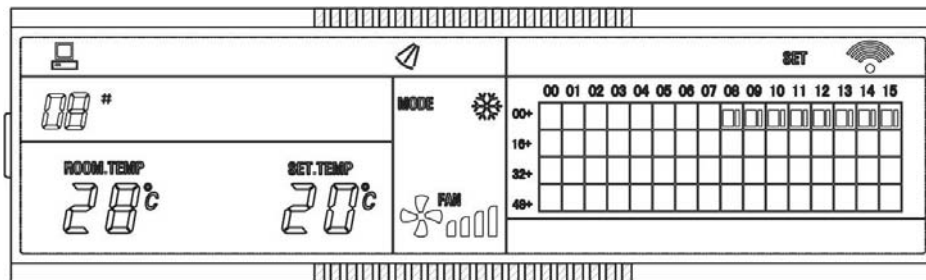

The LCD displays the setting page, and queries the air conditioner with the address of 08. The mode of the air conditioner with the address 08 is: cooling, high speed air supply, swing on, indoor temperature 28°C, setting temperature 22°C and cooling.

In the matrix, only the big black dots from (08, 00+) to (15, 00+) are luminous. It indicates the air conditioners with the addresses from 08 to 15 are in service.

The centralized controller communicates with the computer normally.

- ✓ Fault page display description

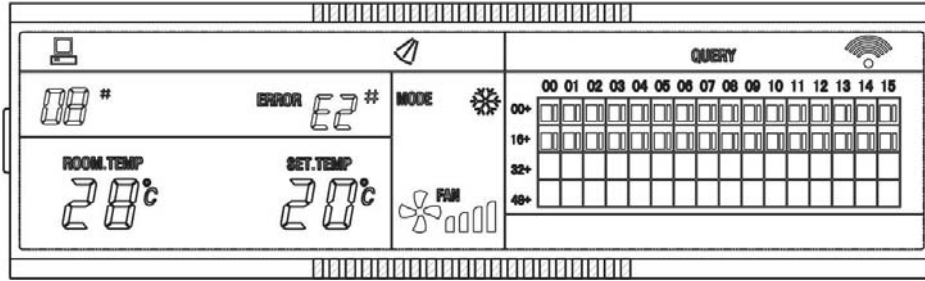

Query the air conditioner with the address of 08 in the query page. The air conditioner with the address of 08 is faulty, and the fault code is E2. The big black dot below (08, 00+) blinks.

In the matrix, only the big and small black dots from (00, 00+) to (15, 16+) illuminate. It indicates the in-service status of the air conditioners with the addresses from 00 to 31.

The centralized controller communicates with the computer normally.

Fault code table:

Fault code	Fault content
EE	Water level detection faults
EC	Cleaning fault
EB	Inverter module protection
EA	Over-current of compressor (4 times)
E9	Fault of communication between main board and display board
E7	EEPROM error
E6	Zero crossing detection error
E5	Outdoor unit fault protection
E4	T2B sensor fault
E3	T2A sensor fault
E2	T1 sensor fault
E1	Communication fault
E0	Phase order error or phase loss
03#	Fault of communication between centralized controller and computer (gateway)
02#	Fault of communication between centralized controller and functional module

01#	Fault of communication between centralized controller and network interface module
00#	Fault of communication between network interface module and main control board

Protection code table:

Fault code	Fault content
PF	Other protection
P8	Over-current of compressor
P7	Power supply over-voltage and undervoltage protection
P6	Discharge low pressure protection
P5	Discharge high pressure protection
P4	Discharge pipe temperature protection
P3	Compressor temperature protection
P2	Condenser hi-temperature protection
P1	Anti-cool air or defrost protection (Only for heat pump units)
P0	Evaporator temperature protection

3.6 Installation

The wireless remote controller is the standard controller for split series air conditioner. Wired controller as optional controller can directly be connected with the display board of the indoor units. Centralized controller should be connected with the main PCB board of the indoor unit through network interface module, which is named as APANM-D01.



1) The installation of network interface module

Outlook of APANM-D01

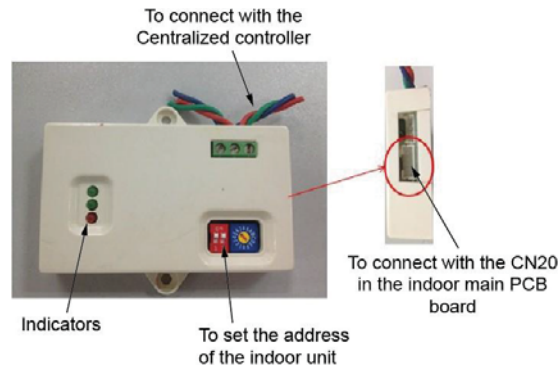

The first green lighter: Ready indicator. When the module and controller is connected rightly, the lighter will be on; otherwise, it will be off. If the unit is in the status of locking remote controller and locking mode, the lighter will flash.

The second green lighter: Communication indicator. When there is any signal between the network interface module and centralized controller, the indicator will be on.

The third lighter: Alarm indicator. If there is any error between the module and controller for communication, it will be on.

Dimension of APANM-D01

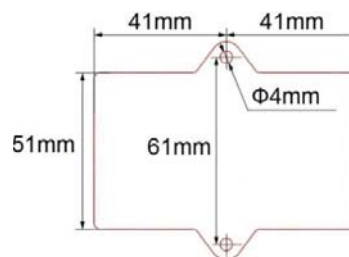

Connect the network interface module with the port CN22 in the main PCB board of indoor unit through the signal wire, which is as the attachment of the module.

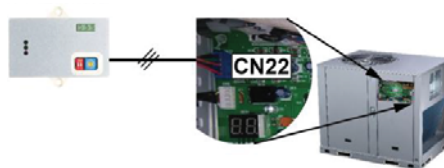

Fix the network interface module on the wall near the indoor unit. And set the different address of the indoor unit.

2) The installation of centralized controller

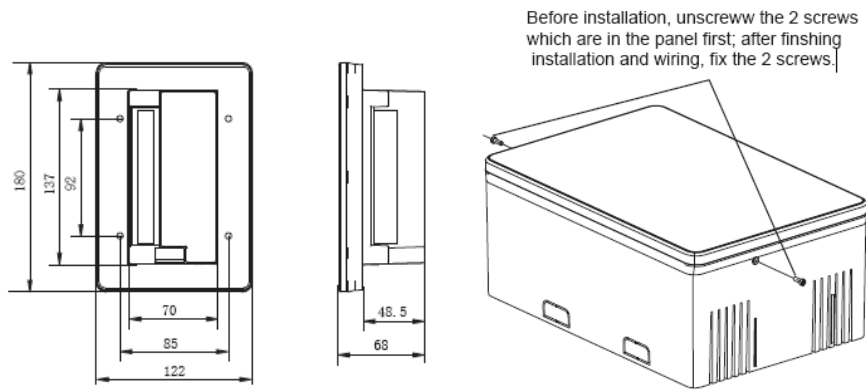

According to size of the hole in controller body, fix the controller on the place as needed. (Unit: mm)

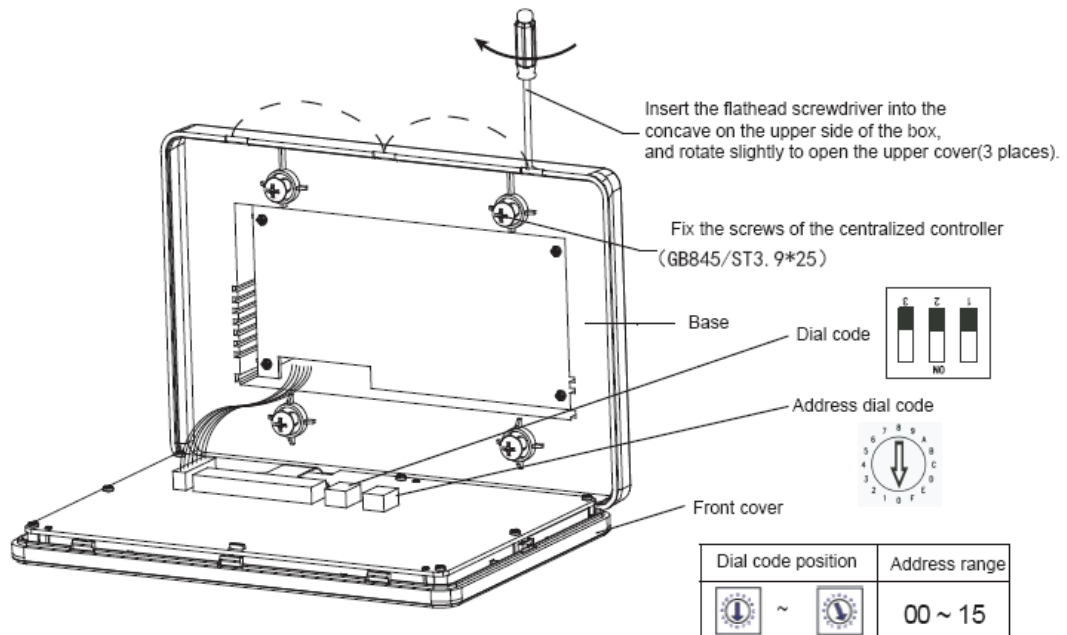

3) The wire connection

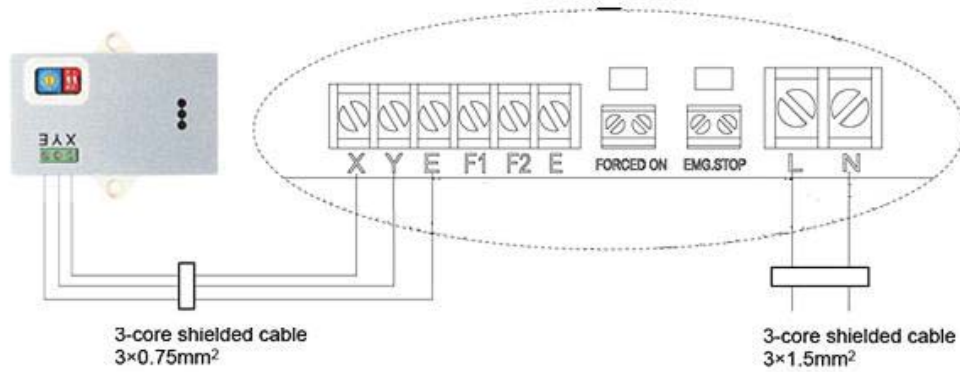
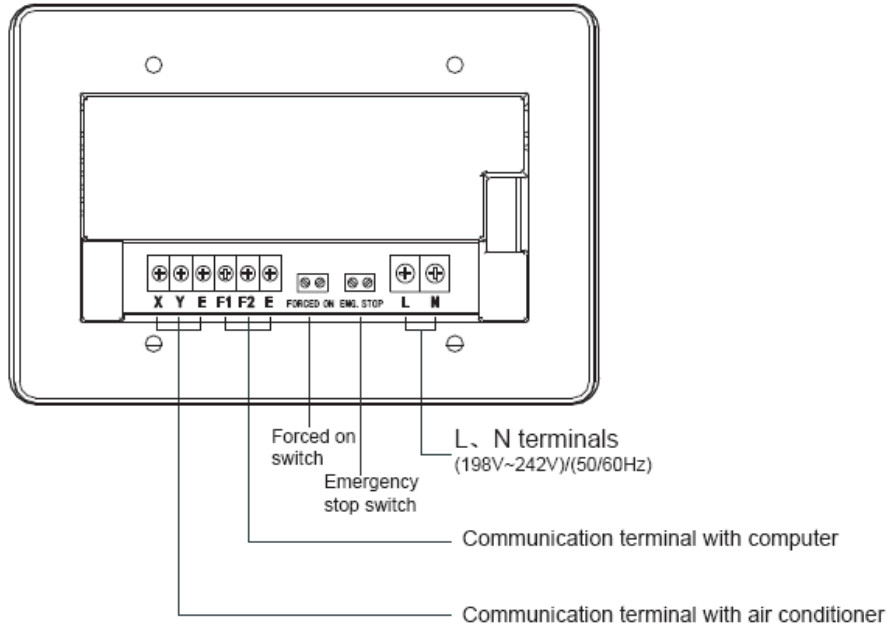

Correct connection

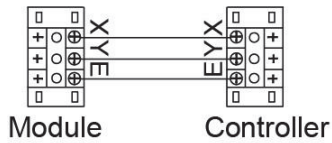

Incorrect connection

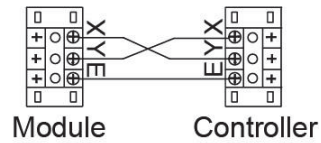

Incorrect connection

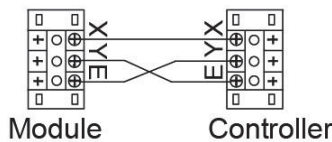

Incorrect connection

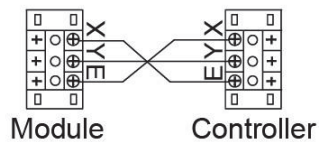

4) System wiring instruction

- ✓ Wiring diagram of building network air conditioning system

Wiring diagram with good communication effect

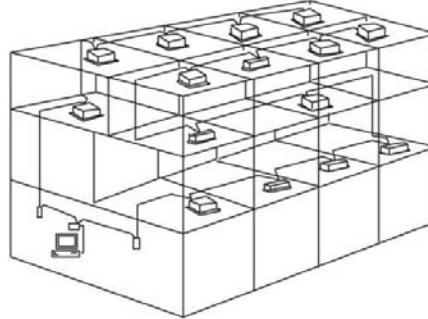

Wiring diagram with poor communication effect (not recommended because it may lead to poor communication)

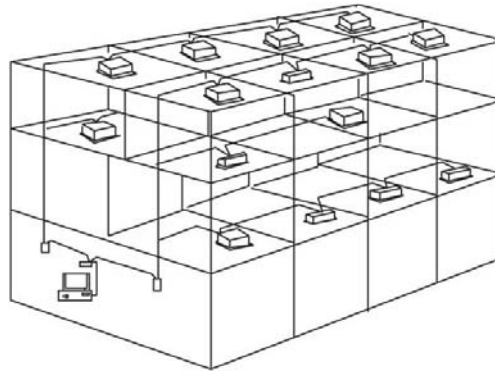

- ✓ System wiring diagram of centralized monitoring and indoor unit of air conditioner

Both of the following wiring modes of centralized monitor and indoor unit are applicable:
(Quantity of indoor units connected with each centralized monitor is less than or equal to 64).

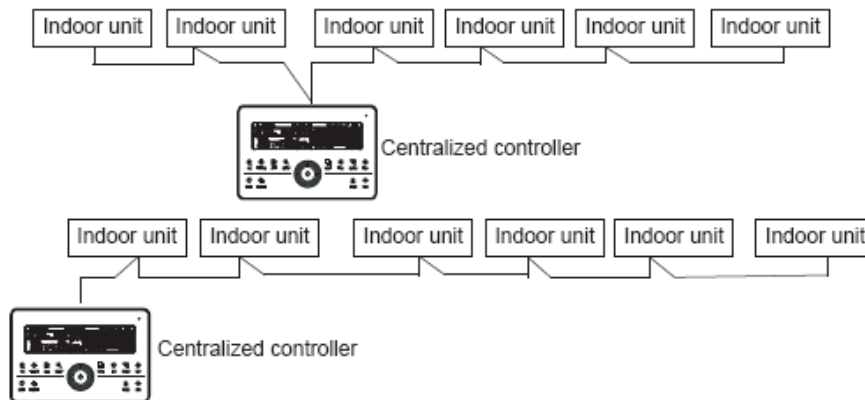



**ENVIRONMENTAL
TECHNOLOGIES LLC.**

17702 Mitchell North, #101
Irvine, CA. 92614 .USA
Tel: 714 795 2830
Fax: 714 966 1646
info@otecus.com
www.otecus.com

OTECTM
AIR CONDITIONING

Showroom & Technology Center
11380 Interchange Circle North
Miramar, FL 33025 .USA
Tel: 305 901 1270
Fax: 954 212 8280
info@otecomega.com
www.otecomega.com

APRHC7A-SM1D0123