

# R410A 50 Hz Universal Outdoor Series (RS485 Communication) Technical & Manual

**220-240V/1/50Hz**  
**380-415/3/50Hz**



# Content

<b>PART 1.General Information .....</b>	<b>1</b>
1.Nomenclature .....	2
2.Model Names of Indoor/Outdoor Units .....	4
3.External Appearance.....	5
4.Features .....	7
<b>Part 2 Indoor Unit.....</b>	<b>8</b>
<b>4-Way Cassette Type .....</b>	<b>8</b>
1. Features .....	9
2. Specification.....	12
3.Dimension.....	15
4. Service Space .....	18
5. Wiring Diagrams .....	19
6. Capacity Table .....	22
7. Electric Characteristics.....	27
8.Sound Levels .....	28
9. Exploded View .....	29
10.Accessories .....	35
11. The Specification of Wiring.....	36
12.Field Wiring.....	37
13.Troubleshooting .....	38
<b>Duct Type .....</b>	<b>39</b>
1. Features .....	40
2.Specification .....	45
3.Dimensions .....	49
4. Service Space .....	52
5.Wiring Diagrams.....	53
6.Capacity Tables .....	58
7.Static Pressure .....	64
8.Electric Characteristics.....	68
9.Sound Levels .....	69
10.Accessories .....	70
11.The Specification of Wiring .....	71
12.Field Wiring.....	72
13.Exploded View .....	73
14.Troubleshooting .....	77
<b>Floor &amp; Ceiling .....</b>	<b>78</b>
1.Features .....	79
2.Specifications .....	81
3.Dimensions .....	83
4.Service Space .....	85
5.Wiring Diagrams.....	86
6.Capacity Table .....	89

7.Electric Characteristics.....	93
8.Sound Levels .....	94
9.Exploded View .....	95
10.Accessories .....	99
11.The Specification of Power.....	100
12.Field Wiring .....	101
13.Troubleshooting .....	102
<b>Part 3 Outdoor Units.....</b>	<b>103</b>
1.Specification .....	104
2.Dimensions .....	107
3.Service Space .....	109
4.Wiring Diagrams.....	110
5.Electric Characteristics.....	115
6.Operation Limits .....	116
7.Sound Levels .....	117
8.Exploded View .....	118
9.Troubleshooting .....	124
<b>Part 4 Installation .....</b>	<b>125</b>
1.Precaution on Installation.....	126
2.Vacuum Dry and Leakage Checking .....	127
3.Additional Refrigerant Charge .....	129
4.Water Drainage .....	130
5.Insulation Work.....	133
6.Test Operation.....	135
<b>Part 5 Control .....</b>	<b>136</b>
1.Wireless Remote Controller .....	137
2.Wired Controller .....	140

## ***R410A 50Hz Universal Outdoor series***

### **PART 1.General Information**

1.Nomenclature .....	2
2.Model Names of Indoor/Outdoor Units .....	4
3.External Appearance.....	5
4.Features .....	7



## 2. Model Names of Indoor/Outdoor Units

### 2.1. Indoor Units

Model name	Dimension (W×H×D) (mm)	Net/Gross weight(kg)	Power supply
SECM012P3A-GWD036	580×275×580	25/27	220~240V-1Ph-50Hz
SECM018P3A-GWC053	580×275×580	25/27	220~240V-1Ph-50Hz
SEVC018S3A-GLD053	840×230×840	24/29	220~240V-1Ph-50Hz
SECS024P3A-GWD070	840×230×840	24/29	220~240V-1Ph-50Hz
SECS036P3A-GWD105	840×285×840	28/33.5	220~240V-1Ph-50Hz
SECS048P3A-GWD140	840×285×840	28/33.5	220~240V-1Ph-50Hz
SECS060P3A-GWD175	840×285×840	30.5/36	220~240V-1Ph-50Hz
SELP018P3A-GLD053	1204×181×510	20/24	220~240V-1Ph-50Hz
SELP024P3A-GCJ070	1532×181×510	24/27.5	220~240V-1Ph-50Hz
SEMP018P3A-GCJ053	1189×260×643	33/36	220~240V-1Ph-50Hz
SEMP024P3A-GCJ070	1189×260×643	33/37	220~240V-1Ph-50Hz
SEMP036P3AGCJ105	1425×260×643	44/48	220~240V-1Ph-50Hz
SEMP048P3A-GWJ140	1425×260×643	44/48	220~240V-1Ph-50Hz
SEMP060P3A-GKI160	1425×260×663	44/48	220~240V-1Ph-50Hz
SEHP048P3A-GWJ140	1175×370×625	45/49	220~240V-1Ph-50Hz
SEHP060P3A-GKI160	1175×370×625	45/49	220~240V-1Ph-50Hz
SEFC018C3A-GWD053	880×635×203	30/35	220~240V-1Ph-50Hz
SEFC024C3A-GWD070	245×680×247	35/41	220~240V-1Ph-50Hz
SEFC036C3A-GWD105	1245×680×247	37/43	220~240V-1Ph-50Hz
SEFC048C3A-GWD140	1670×680×247	47/54	220~240V-1Ph-50Hz
SEFC060C3A-GWD160	1670×680×247	47/54	220~240V-1Ph-50Hz

### 2.2. Outdoor Units

Model name	Dimension (W×H×D) (mm)	Net/Gross weight(kg)	Power supply
SCHE012C3A-GSC036	866×535×304	36/38	220~240V-1Ph-50Hz
SCHE018C3A-GSC053	866×535×304	41/43	220~240V-1Ph-50Hz
SCHE024C3A-GSC070	930×700×370	52/56	220~240V-1Ph-50Hz
SCHE036C3A-GSC105	1070×995×400	92/100	220~240V-1Ph-50Hz
SCHE036C7A-GSC105	1070×995×400	92/100	380~415V-3Ph-50Hz
SCHE048C7A-GSC140	911×1335×400	99/110	380~415V-3Ph-50Hz
SCHE060C7A-GSC160	911×1335×400	99/110	380~415V-3Ph-50Hz

### 3.External Appearance

#### 3.1. Indoor unit

4-way cassette (Compact type)



4-way Cassette



Low ESP Duct

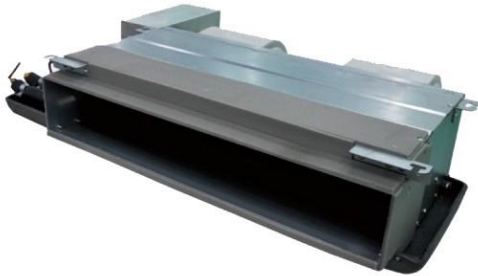

Middle ESP Duct



High ESP Duct



Floor & Ceiling  
(18k Btu/h)



Floor & Ceiling  
(24k-36k Btu/h)



Floor & Ceiling  
(48k-60k Btu/h)

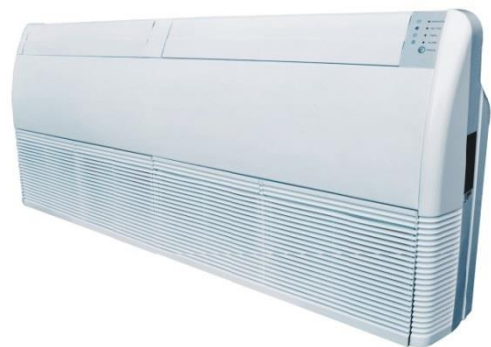

### 3.2.Outdoor unit

SCHE0012P3A,SCHE018P3A



SCHE024P3A



SCHE036P3A



SCHE048P7A,SCHE060P7A



## 4.Features

4.1 RS485 communication wired connection, universal type, no need to special training for installation workers.

4.2 Low temperature module optional, can cooling under circumstance temperature  $-10^{\circ}\text{C}$ .

4.3 High quality coils

The coil is constructed of advanced inner grooved copper tube and aluminum fins.

4.4 Low operation sound level: Well-known stable and quiet running fan motor.

4.5 Well-known compressor, Panasonic & Hitachi.

4.6 Compact design: Smaller dimension and larger stuffing capacity.

4.7 Universal outdoor unit design.

4.8 R410A environment friendly refrigerant.

4.9 CE certification, ROHS certification.

## Part 2 Indoor Unit

### 4-Way Cassette Type

1. Features.....	9
2. Specification .....	12
3. Dimension.....	15
4. Service Space .....	18
5. Wiring Diagrams .....	19
6. Capacity Table.....	22
7. Electric Characteristics.....	27
8.Sound Levels .....	28
9.Exploded View .....	29
10.Accessories .....	35
11.The Specification of Wiring.....	36
12.Field Wiring.....	37
13.Troubleshooting.....	38

# 1. Features

## Four-Way Cassette (Compact Type)

(1) Brand-new panel. Indoor unit use uniform panel, simple and convenient. For standard cassette, digital display is optional .



(2) Ultra-thin body design, the min. height is only 275mm for compact and 230mm for standard cassette , save installation space.

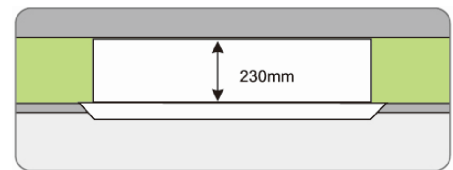

(3) 4-way air flow, cold air can reach each corner of the room, providing a stable and comfortable environment.



(4) 3 fan speed, meet for different requirement.

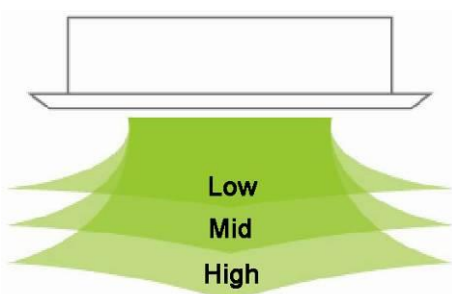

(5) New streamlined fan design.





(6) Energy saving and healthy, adopting hydrophilic aluminum fins increasing heat-exchange efficiency.

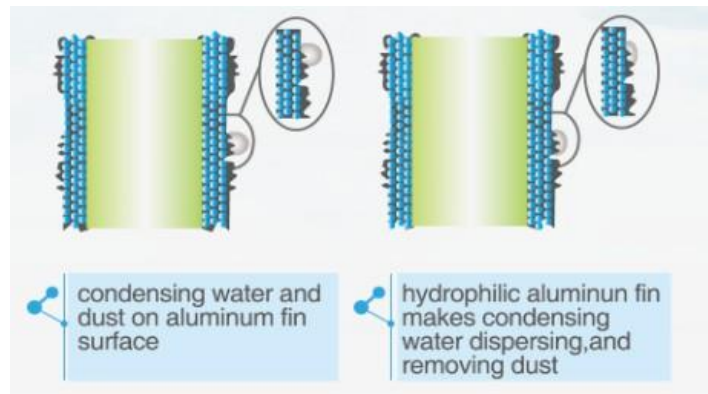

(7) Easy and convenient installation and maintenance, washable filter design.



(8) Built-in water pump, water head up to 700mm for compact and 1200mm for standard .

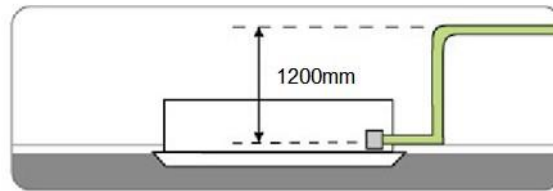

(9) Fire resistance design, the E-box with galvanized steel built-in body easy for maintenance.



(10) Add 4 interfaces in body, can be connected with duct to another room. Fresh air makes air quality more healthy and comfortable. This function is available for standard cassette.



(11) Multi protection and auto-restart function.

(12) Standard for wireless controller; option for wired controller.



Standard



optional





## 2. Specification

Model			SECM012P3A	SECM018P3A	SECS018P3A
Indoor power supply		V/Ph/Hz	220~240/1/50	220~240/1/50	220~240/1/50
Cooling	Capacity	Btu/h	12000	18000	18000
		KW	3.5	5.3	5.3
	Input	W	75	75	65
	Rated current	A	0.4	0.4	0.4
	EER	W/W	2.66	2.68	2.70
Heating	Capacity	Btu/h	13200	20000	20000
		KW	3.9	5.9	5.9
	Input	W	75	75	65
	Rated current	A	0.4	0.4	0.4
	COP	W/W	2.88	3.34	3.31
Indoor fan motor	Model		YDK-35T-4	YDK-35T-4 1	YDK-45Q-6P3
	Input	W	75	75	65
	Capacitor	μF	2.5	2.5	3
	Speed(Hi/Me/Lo)	r/min	950/850/700	1050/950/830	480/430/380
Indoor coil	Number of rows		2	2	2
	Tube pitch(a) x row pitch(b)	mm	21×12.7	21×12.7	21×13.37
	Fin spacing	mm	1.55	1.55	1.45
	Fin type		Hydrophilic	Hydrophilic	Hydrophilic
	Tube outside dia. and type	mm	Φ7	Φ7	Φ7
			inner grooved	inner grooved	inner grooved
	Coil length x height x width	mm	1137×210×25.4	1791×168×25.4	2000×168×26.74
Number of circuits		5	5	8	
Indoor air flow(High speed)		m <sup>3</sup> /h	566	700	810
Indoor noise level		dB(A)	40~45	43~48	44~48
Indoor unit	Dimension(W*H*D)	Body(mm)	580×275×580	580×275×580	840×230×840
		Panel(mm)	650×30×650	650×30×650	950×50×950
	Packing(W*H*D)	Body(mm)	745×375×675	745×375×675	920×265×920
		Panel(mm)	750×95×750	750×95×750	1030×105×1030
	Net/Gross weight	Body(Kg)	25/27	25/27	24/29
		Panel(Kg)	2.7/4.0	2.7/4.0	5.4/8.0
Max pressure		MPa	4.0	4.0	4.0
Refrigerant type			R410A	R410A	R410A
Refrigerant piping	Liquid side/Gas side	mm	Φ6.35/Φ12.7	Φ6.35/Φ12.7	Φ6.35/Φ12.7
Drainage pipe		mm	DN25	DN25	DN25
Standard controller			Standard for remote controller(wired controller for option)		

Operation temp		°C	16~32	16~32	16~32
Ambient temp	cooling	°C	18-43	18-43	18-43
	heating	°C	-7~24	-7~24	-7~24
Application area		m <sup>2</sup>	15~25	20-35	20-35
Stuffing Quantity(20'/40'/40'HQ)		set	120/240/270	120/240/270	75/155/170

**Notes:**

1. Nominal cooling capacities are based on the following conditions:

Indoor temp: 27°CDB, 19°CWB; Outdoor temp: 35°CDB; Equivalent ref. Piping: m(horizontal)

2. Nominal heating capacities are based on the following conditions:

Indoor temp: 20°CDB; Outdoor temp: 7°CDB, 6°CWB; Equivalent ref. Piping: m(horizontal)

3. Actual noise level may differ, depending on the room structure, etc, since these noise values are from an anechoic room.

Model			SECS024P3A	SECS036P3A	SECS048P3A	SECS060P3A
Indoor power supply		V/Ph/Hz	220~240/1/50	220~240/1/50	220~240/1/50	220~240/1/50
Cooling	Capacity	Btu/h	24000	36000	48000	60000
		KW	7.1	10.5	14	16
	Input	W	150	160	180	180
	Rated current	A	0.7	0.8	0.8	0.8
	EER	W/W	2.78	2.65	2.7	2.72
Heating	Capacity	Btu/h	26000	39000	52000	60000
		KW	7.7	11.5	15.2	16.0
	Input	W	150	160	180	180
	Rated current	A	0.7	0.8	0.8	0.8
	COP	W/W	3.42	3.06	2.88	2.68
Indoor fan motor	Model		YDK-45Q-6P3	YDK-75T-6	YDK-75Q-6P3-1	YDK-75Q-6P3-1
	Input	W	150	160	180	180
	Capacitor	μF	3	4	5	5
	Speed(Hi/Me/Lo)	r/min	850/790/600	760/680/580	850/750/650	850/750/650
Indoor coil	Number of rows		2	2	2	3
	Tube pitch(a) x row pitch(b)	mm	21×13.37	21×13.37	21×13.37	21×13.37
	Fin spacing	mm	1.45	1.45	1.45	1.6
	Fin type		Hydrophilic	Hydrophilic	Hydrophilic	Hydrophilic Aluminum
	Tube outside dia. and type	mm	Φ7	Φ7	Φ7	Φ7
			inner grooved	inner grooved	inner grooved	Inner grooved
	Coil length x height x width	mm	2000×168×26.7	2000×252×26.7	2000×252×26.7	2000×252×40.1
Number of circuits		8	12	12	6	
Indoor air flow(High speed)		m <sup>3</sup> /h	1200	1700	1900	1900
Indoor noise level		dB(A)	44~48	44~48	45~52	45~52

Indoor unit	Dimension(W*H*D)	Body(mm)	840×230×840	840×285×840	840×285×840	840×285×840
		Panel(mm)	950×50×950	950×50×950	950×50×950	950×50×950
	Packing(W*H*D)	Body(mm)	920×265×920	920×310×920	920×310×920	920×310×920
		Panel(mm)	1030×105×1030	1030×105×1030	1030×105×1030	1030×105×1030
	Net/Gross weight	Body(Kg)	24/29	28/33.5	28/33.5	30.5/36
		Panel(Kg)	5.4/8.0	5.4/8.0	5.4/8.0	5.4/8.0
Max pressure		MPa	4.0	4.0	4.5	4.5
Refrigerant type			R410A	R410A	R410A	R410A
Refrigerant piping	Liquid side/Gas side	mm	Φ9.52/Φ15.88	Φ9.52/Φ19.05	Φ9.52/Φ19.05	Φ9.52/Φ19.05
Drainage pipe		mm	DN25	DN25	DN25	DN25
Standard controller						
Operation temp		°C	16~32	16~32	16~32	16~32
Ambient temp	cooling	°C	18-43	18-43	18-43	18-43
	heating	°C	-7~24	-7~24	-7~24	-7~24
Application area		m <sup>2</sup>	28-50	40-70	55~95	60~105
Stuffing Quantity(20'/40'/40'HQ)		set	75/155/170	65/130/150	65/130/150	65/130/150

**Notes:**

1. Nominal cooling capacities are based on the following conditions:

Indoor temp: 27°CDB, 19°CWB; Outdoor temp: 35°CDB; Equivalent ref. Piping: 5m(horizontal)

2. Nominal heating capacities are based on the following conditions:

Indoor temp: 20°CDB; Outdoor temp: 7°CDB, 6°CWB; Equivalent ref. Piping: 5m(horizontal)

3. Actual noise level may differ, depending on the room structure, etc. since these noise values are from an anechoic room.

### 3.Dimension

#### 3.1 SECM012P3A, SECM018P3A

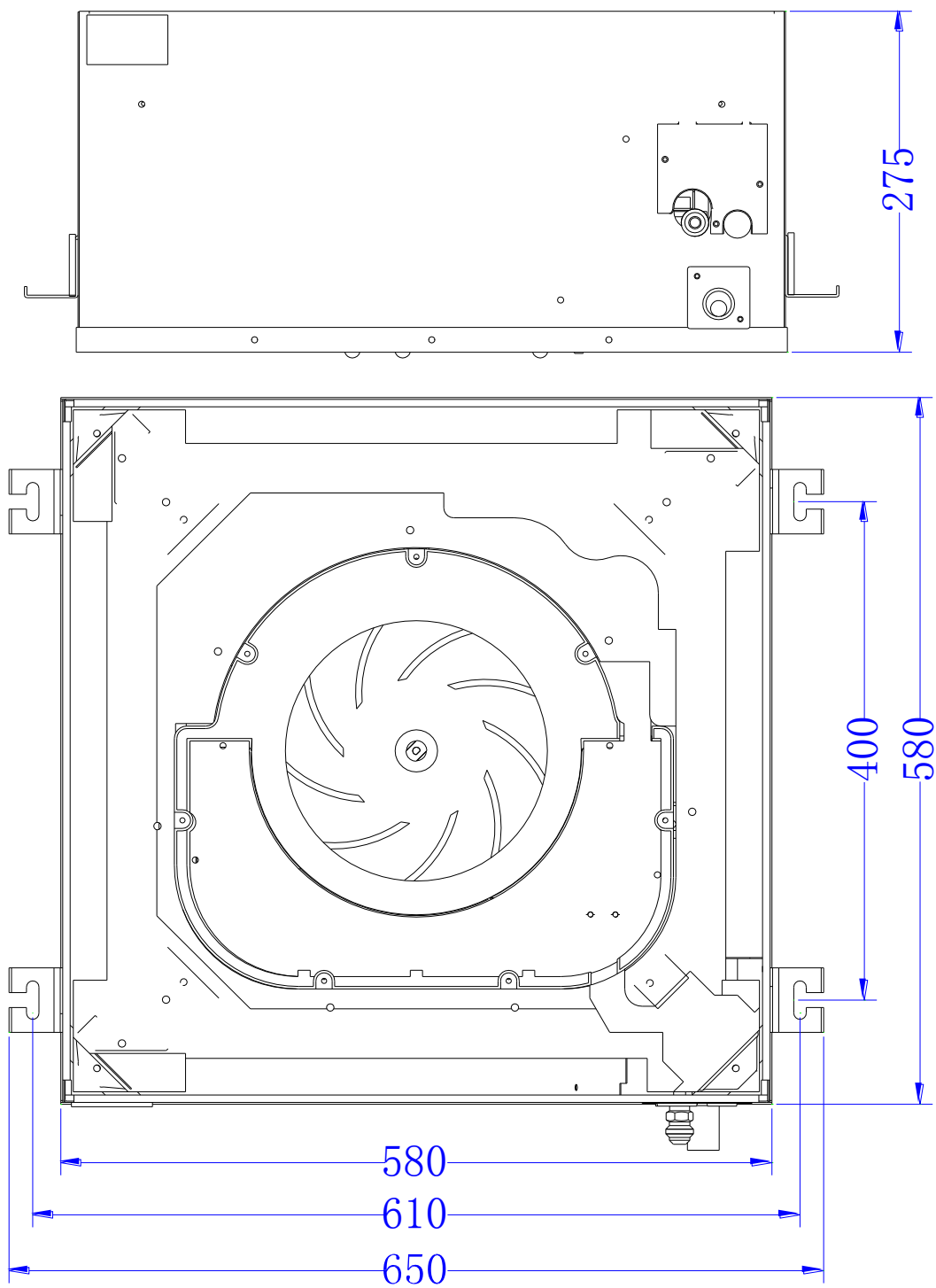

### 3.2 SECS018P3A,SECS024P3A

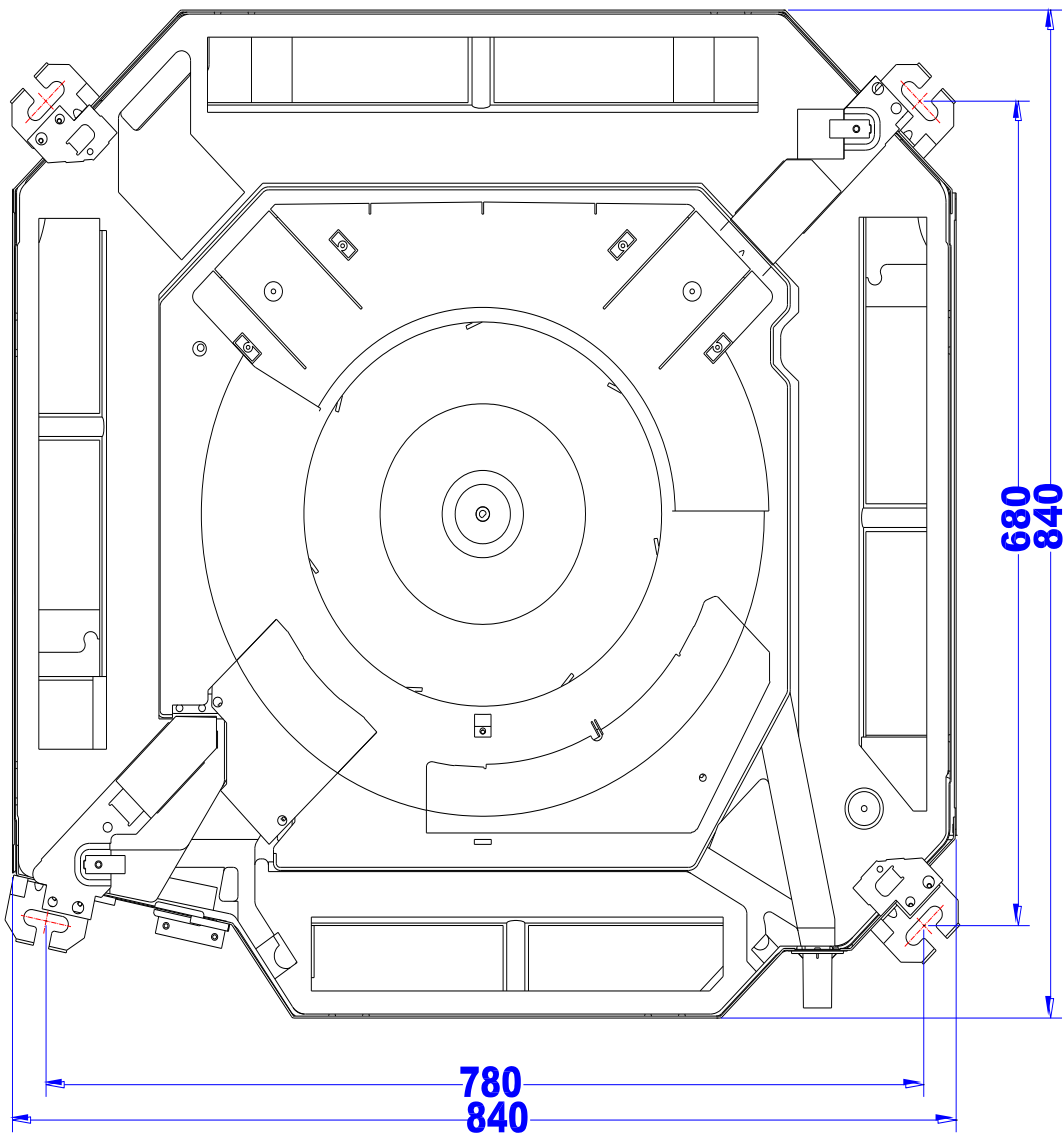
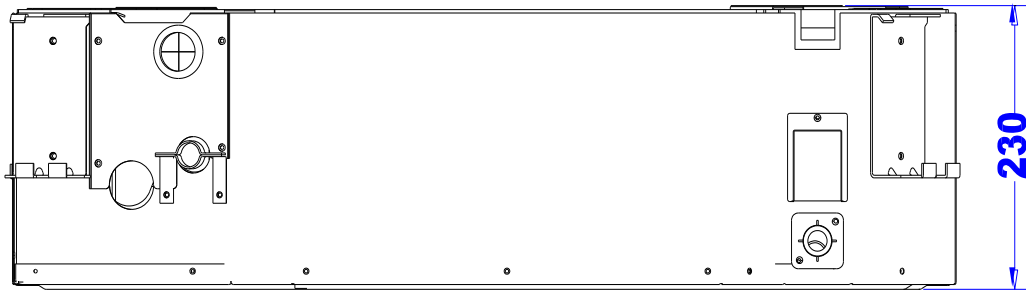

### 3.3 SECS036P3A,SECS048P3A,SECS060P3A

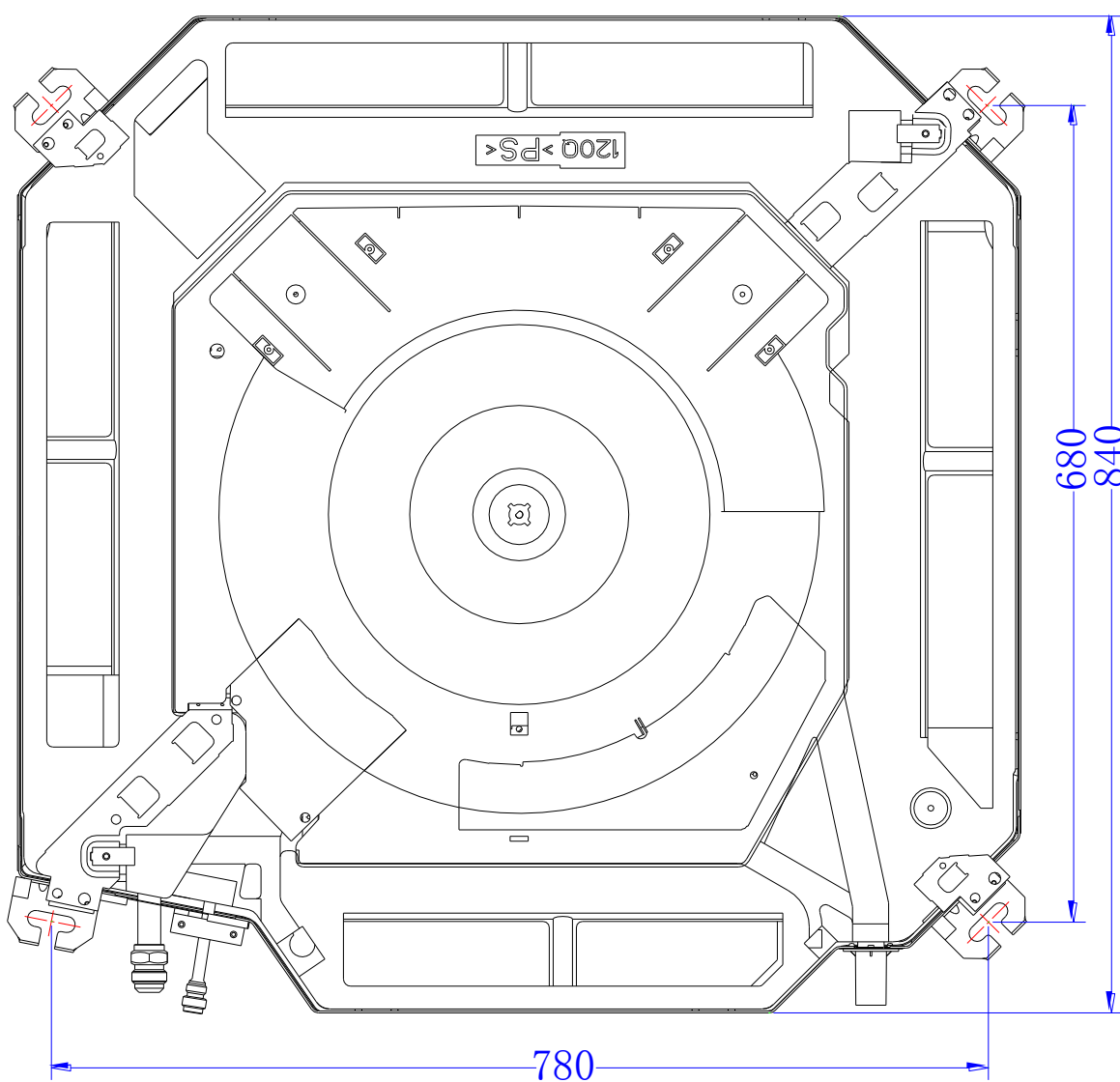
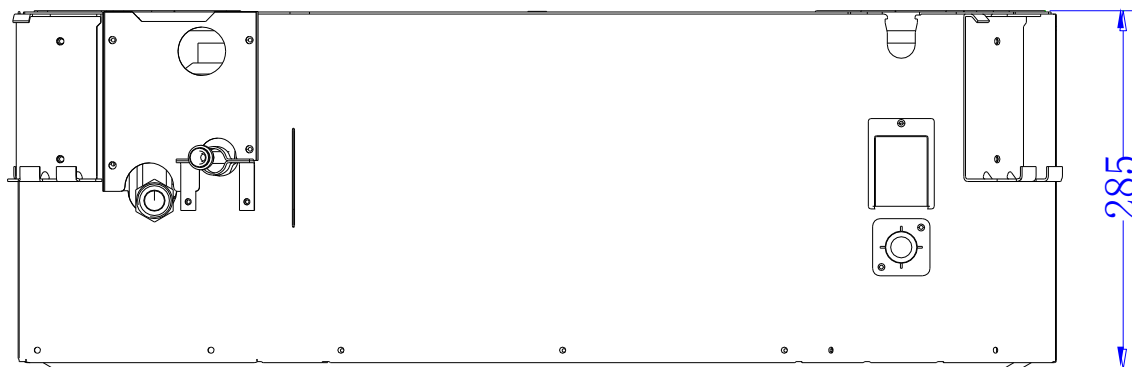

## 4. Service Space

The indoor unit should be installed in a location that meets the following requirements:

- 4.1 There is enough interspace for installation and maintenance.
- 4.2 The ceiling is horizontal, and its structure can endure the weight of the indoor unit.
- 4.3 The outlet and the inlet are not impeded, and the influence of external air is the least.
- 4.4 The air flow can reach throughout the room.
- 4.5 The connecting pipe and drainpipe could be extracted out easily.
- 4.6 There is no direct radiation from heaters.

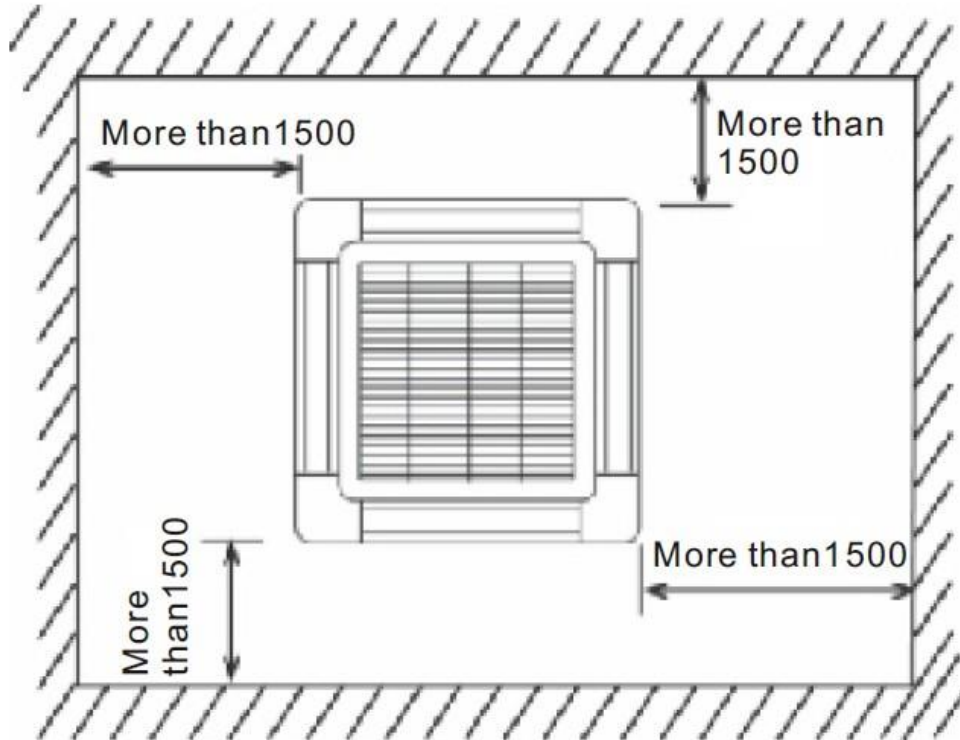

# 5. Wiring Diagrams

## 5.1 SECM012P3A, SECM018P3A, SECS018P3A

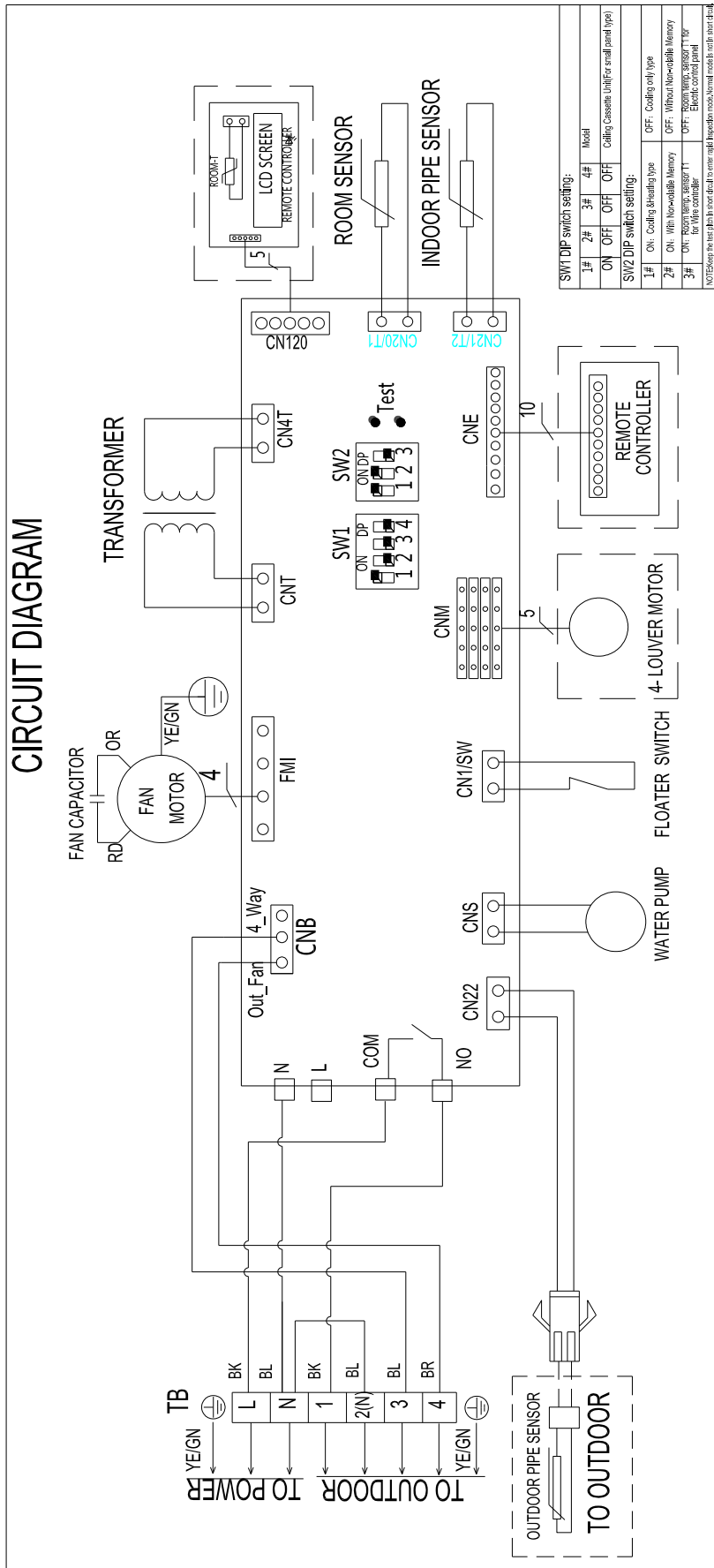



5.2 SECS024P3A, SECS036P3A

CIRCUIT DIAGRAM

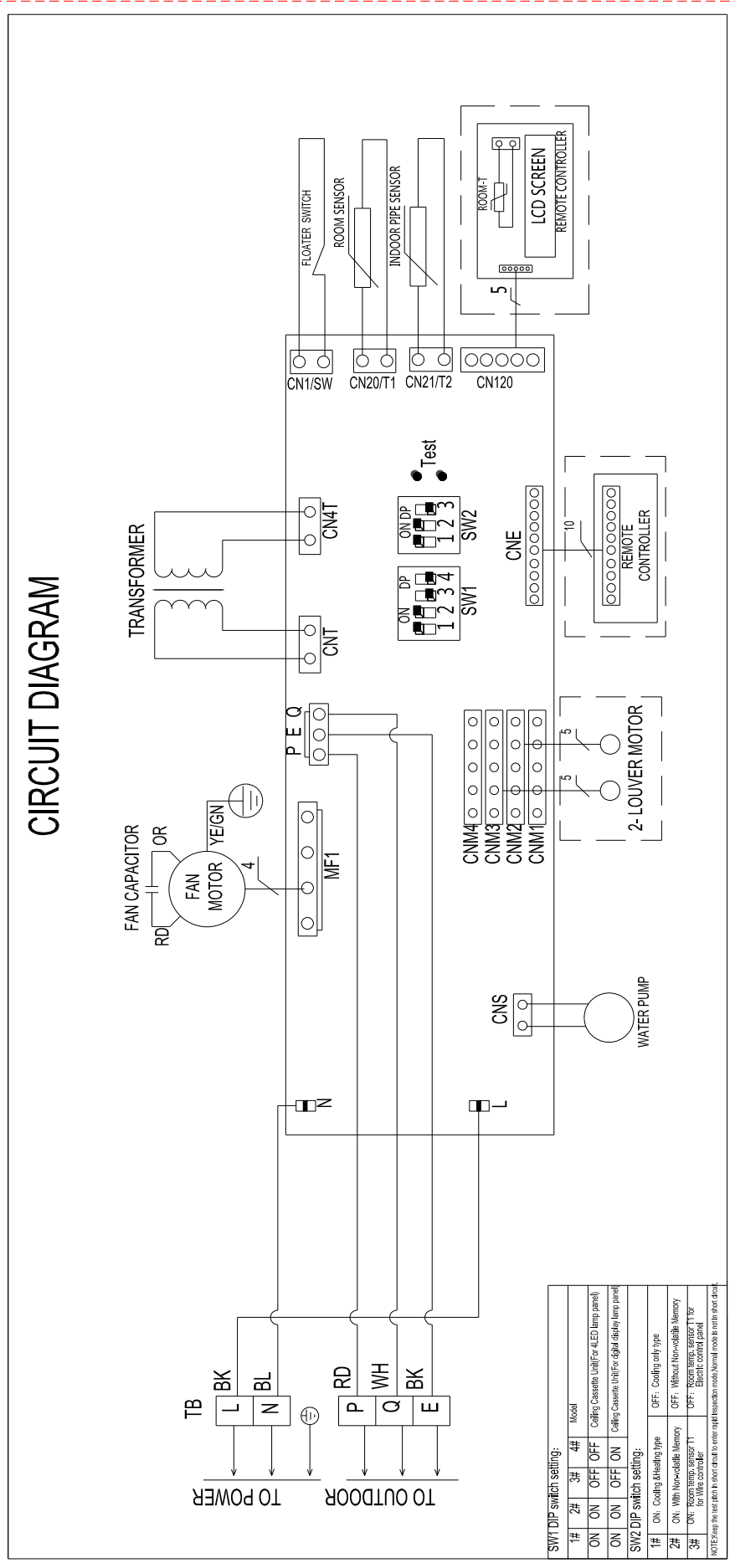

5.3 SECS048P3A, SECS060P3A

CIRCUIT DIAGRAM

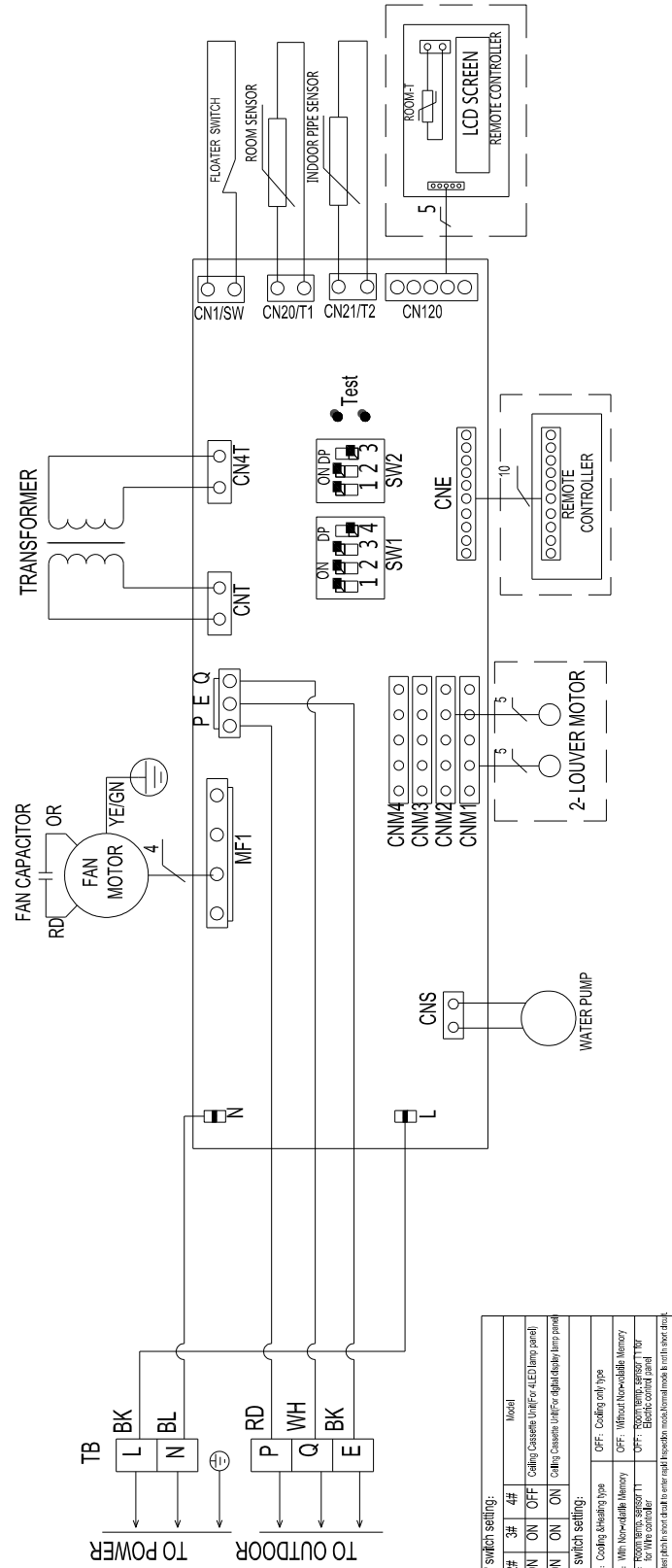

SW1 DIP switch setting:

1#	2#	3#	4#	Model
ON	ON	ON	OFF	Calling Cassette Unit For 4LED lamp panel
ON	ON	ON	ON	Calling Cassette Unit For digital display lamp panel

SW2 DIP switch setting:

1#	2#	3#	4#	Model
ON	ON	ON	OFF	Without Non-volatile Memory
ON	ON	ON	ON	Room Temp. sensor "1" for Electric control panel
ON	ON	ON	ON	Room Temp. sensor "1" for Electric control panel

NOTE: Keep the DIP switch in correct circuit in order to avoid the outdoor model mismatch in each indoor unit.

## 6. Capacity Table

### Cooling

#### 6.1 SECM012P3A

MODEL		SECM012P3A					
COOLING		OUTDOOR TEMPERATURE DRY					
Indoor Conditions		21°C	25°C	30°C	35°C	40°C	43°C
21°C D 15°C W	Total capacity kW	3.29	3.25	3.22	3.17	2.85	2.42
	Input kW.	1.16	1.19	1.21	1.25	1.33	1.38
24°C D 17°C W	Total capacity kW	3.45	3.42	3.38	3.33	2.99	2.54
	Input kW.	1.19	1.21	1.24	1.27	1.35	1.41
27°C D 19°C W	Total capacity kW	3.62	3.59	3.55	3.50	3.14	2.67
	Input kW.	1.21	1.24	1.26	1.30	1.38	1.44
29°C D 19°C W	Total capacity kW	3.77	3.73	3.69	3.64	3.27	2.78
	Input kW.	1.24	1.26	1.29	1.33	1.41	1.46
32°C D 23°C W	Total capacity kW	3.92	3.88	3.84	3.78	3.40	2.89
	Input kW.	1.26	1.29	1.31	1.35	1.44	1.49

#### 6.2 SECM018P3A

MODEL		SECM018P3A					
COOLING		OUTDOOR TEMPERATURE DRY					
Indoor Conditions		21°C	25°C	30°C	35°C	40°C	43°C
21°C D 15°C W	Total capacity kW	4.98	4.93	4.88	4.81	4.32	3.67
	Input kW.	1.79	1.83	1.86	1.92	2.04	2.12
24°C D 17°C W	Total capacity kW	5.23	5.18	5.12	5.05	4.53	3.85
	Input kW.	1.83	1.86	1.90	1.96	2.08	2.17
27°C D 19°C W	Total capacity kW	5.49	5.43	5.38	5.30	4.76	4.04
	Input kW.	1.86	1.90	1.94	2.00	2.12	2.21
29°C D 19°C W	Total capacity kW	5.71	5.65	5.60	5.51	4.95	4.21
	Input kW.	1.90	1.94	1.98	2.04	2.17	2.25
32°C D 23°C W	Total capacity kW	5.94	5.88	5.82	5.73	5.14	4.37
	Input kW.	1.94	1.98	2.02	2.08	2.21	2.30

#### 6.3 SECS018P3A

MODEL		SECS018P3A					
COOLING		OUTDOOR TEMPERATURE DRY					
Indoor Conditions		21°C	25°C	30°C	35°C	40°C	43°C
21°C D 15°C W	Total capacity kW	4.98	4.93	4.88	4.81	4.32	3.67
	Input kW.	1.78	1.82	1.86	1.91	2.03	2.11
24°C D 17°C W	Total capacity kW	5.23	5.18	5.12	5.05	4.53	3.85
	Input kW.	1.82	1.86	1.89	1.95	2.07	2.16
27°C D 19°C W	Total capacity kW	5.49	5.43	5.38	5.30	4.76	4.04
	Input kW.	1.86	1.89	1.93	1.99	2.11	2.20
29°C D 19°C W	Total capacity kW	5.71	5.65	5.60	5.51	4.95	4.21
	Input kW.	1.89	1.93	1.97	2.03	2.16	2.24
32°C D 23°C W	Total capacity kW	5.94	5.88	5.82	5.73	5.14	4.37
	Input kW.	1.93	1.97	2.01	2.07	2.20	2.29

**6.4 SECS024P3A**

MODEL		SECS024P3A					
COOLING		OUTDOOR TEMPERATURE DRY					
Indoor Conditions		21°C	25°C	30°C	35°C	40°C	43°C
21°C D 15°C W	Total capacity kW	6.67	6.60	6.54	6.44	5.78	4.91
	Input kW.	2.28	2.33	2.38	2.45	2.60	2.71
24°C D 17°C W	Total capacity kW	7.00	6.93	6.86	6.76	6.07	5.16
	Input kW.	2.33	2.38	2.43	2.50	2.65	2.76
27°C D 19°C W	Total capacity kW	7.35	7.28	7.21	7.10	6.37	5.42
	Input kW.	2.38	2.43	2.48	2.55	2.71	2.82
29°C D 19°C W	Total capacity kW	7.65	7.57	7.50	7.38	6.63	5.63
	Input kW.	2.43	2.48	2.53	2.60	2.76	2.87
32°C D 23°C W	Total capacity kW	7.95	7.87	7.79	7.68	6.89	5.86
	Input kW.	2.48	2.53	2.57	2.65	2.82	2.93

**6.5 SECS036P3A**

MODEL		SECS036P3A					
COOLING		OUTDOOR TEMPERATURE DRY					
Indoor Conditions		21°C	25°C	30°C	35°C	40°C	43°C
21°C D 15°C W	Total capacity kW	9.86	9.77	9.67	9.53	8.55	7.27
	Input kW.	3.55	3.62	3.69	3.81	4.04	4.20
24°C D 17°C W	Total capacity kW	10.36	10.25	10.15	10.00	8.98	7.63
	Input kW.	3.62	3.69	3.77	3.88	4.12	4.29
27°C D 19°C W	Total capacity kW	10.88	10.76	10.66	10.50	9.43	8.01
	Input kW.	3.69	3.77	3.85	3.96	4.20	4.37
29°C D 19°C W	Total capacity kW	11.31	11.20	11.09	10.92	9.80	8.33
	Input kW.	3.77	3.85	3.92	4.04	4.29	4.46
32°C D 23°C W	Total capacity kW	11.76	11.64	11.53	11.36	10.19	8.66
	Input kW.	3.85	3.92	4.00	4.12	4.37	4.55

**6.6 SECS048P3A**

MODEL		SECS048P3A					
COOLING		OUTDOOR TEMPERATURE DRY					
Indoor Conditions		21°C	25°C	30°C	35°C	40°C	43°C
21°C D 15°C W	Total capacity kW	13.15	13.02	12.89	12.70	11.40	9.69
	Input kW.	4.64	4.74	4.83	4.98	5.28	5.50
24°C D 17°C W	Total capacity kW	13.81	13.67	13.53	13.33	11.97	10.17
	Input kW.	4.74	4.83	4.93	5.08	5.39	5.61
27°C D 19°C W	Total capacity kW	14.50	14.35	14.21	14.00	12.57	10.68
	Input kW.	4.83	4.93	5.03	5.18	5.50	5.72
29°C D 19°C W	Total capacity kW	15.08	14.93	14.78	14.56	13.07	11.11
	Input kW.	4.93	5.03	5.13	5.28	5.61	5.83
32°C D 23°C W	Total capacity kW	15.68	15.52	15.37	15.14	13.59	11.55
	Input kW.	5.03	5.13	5.23	5.39	5.72	5.95

## 6.7 SECS060P3A

MODEL		SECS060P3A					
COOLING		OUTDOOR TEMPERATURE DRY					
Indoor Conditions		21°C	25°C	30°C	35°C	40°C	43°C
21°C D 15°C W	Total capacity kW	15.03	14.88	14.73	14.51	13.03	11.07
	Input kW.	5.27	5.38	5.48	5.65	5.99	6.24
24°C D 17°C W	Total capacity kW	15.78	15.62	15.46	15.23	13.68	11.62
	Input kW.	5.38	5.48	5.60	5.77	6.12	6.37
27°C D 19°C W	Total capacity kW	16.57	16.40	16.24	16.00	14.37	12.21
	Input kW.	5.48	5.60	5.71	5.88	6.24	6.49
29°C D 19°C W	Total capacity kW	17.23	17.06	16.89	16.64	14.94	12.70
	Input kW.	5.60	5.71	5.82	5.99	6.37	6.62
32°C D 23°C W	Total capacity kW	17.92	17.74	17.57	17.30	15.53	13.20
	Input kW.	5.71	5.82	5.94	6.12	6.49	6.75

## Heating

### 6.8 SECM012P3A

MODEL		SECM012P3A						
HEATING		OUTDOOR CONDITIONS						
Indoor Conditions		24°C DB 18°CWB	12°C DB 11°CWB	7°C DB 6°C WB	4°C DB 3°C WB	0°C DB -1°CWB	-5°C DB -6°CWB	-7°C DB -8°CWB
15°C	Capacity kW	4.34	4.25	4.19	3.99	3.85	3.55	3.36
	Input kW.	1.23	1.25	1.28	1.29	1.30	1.31	1.32
18°C	Capacity kW	4.13	4.05	3.99	3.80	3.67	3.38	3.20
	Input kW.	1.25	1.28	1.30	1.32	1.32	1.34	1.34
20°C	Capacity kW	3.94	3.86	3.80	3.62	3.50	3.22	3.05
	Input kW.	1.38	1.31	1.33	1.34	1.35	1.36	1.37
22°C	Capacity kW	3.75	3.67	3.62	3.45	3.33	3.06	2.90
	Input kW.	1.30	1.33	1.36	1.37	1.38	1.39	1.40
27°C	Capacity kW	3.57	3.50	3.45	3.28	3.17	2.92	2.77
	Input kW.	1.33	1.36	1.38	1.40	1.41	1.42	1.43

### 6.9 SECM018P3A

MODEL		SECM018P3A						
HEATING		OUTDOOR CONDITIONS						
Indoor Conditions		24°C DB 18°C WB	12°C DB 11°C WB	7°C DB 6°C WB	4°C DB 3°C WB	0°C DB -1°C WB	-5°C DB -6°C WB	-7°C DB -8°C WB
15°C	Capacity kW	6.69	6.56	6.46	6.15	5.94	5.47	5.18
	Input kW.	1.68	1.72	1.75	1.77	1.78	1.79	1.80
18°C	Capacity kW	6.37	6.25	6.15	5.86	5.66	5.21	4.93
	Input kW.	1.71	1.75	1.79	1.80	1.81	1.83	1.84
20°C	Capacity kW	6.07	5.95	5.86	5.58	5.39	4.96	4.70
	Input kW.	1.88	1.79	1.82	1.84	1.85	1.86	1.88
22°C	Capacity kW	5.78	5.66	5.58	5.31	5.13	4.72	4.48
	Input kW.	1.78	1.82	1.86	1.88	1.89	1.90	1.91
27°C	Capacity kW	5.51	5.39	5.32	5.06	4.89	4.50	4.26
	Input kW.	1.82	1.86	1.89	1.91	1.92	1.94	1.95

**6.10 SECS018P3A**

MODEL		SECS018P3A						
HEATING		OUTDOOR CONDITIONS						
Indoor Conditions		24°C DB 18°C WB	12°C DB 11°C WB	7°C DB 6°C WB	4°C DB 3°C WB	0°C DB -1°C WB	-5°C DB -6°C WB	-7°C DB -8°C WB
15°C	Capacity kW	6.69	6.56	6.46	6.15	5.94	5.47	5.18
	Input kW.	1.59	1.62	1.65	1.67	1.68	1.69	1.70
18°C	Capacity kW	6.37	6.25	6.15	5.86	5.66	5.21	4.93
	Input kW.	1.62	1.65	1.69	1.70	1.71	1.73	1.74
20°C	Capacity kW	6.07	5.95	5.86	5.58	5.39	4.96	4.70
	Input kW.	1.78	1.69	1.72	1.74	1.75	1.76	1.77
22°C	Capacity kW	5.78	5.66	5.58	5.31	5.13	4.72	4.48
	Input kW.	1.68	1.72	1.76	1.77	1.78	1.80	1.81
27°C	Capacity kW	5.51	5.39	5.32	5.06	4.89	4.50	4.26
	Input kW.	1.72	1.76	1.79	1.81	1.82	1.83	1.84

**6.11 SECS024P3A**

MODEL		SECS024P3A						
HEATING		OUTDOOR CONDITIONS						
Indoor Conditions		24°C DB 18°C WB	12°C DB 11°C WB	7°C DB 6°C WB	4°C DB 3°C WB	0°C DB -1°C WB	-5°C DB -6°C WB	-7°C DB -8°C WB
15°C	Capacity kW	8.68	8.51	8.38	7.98	7.71	7.09	6.72
	Input kW.	2.08	2.12	2.16	2.19	2.19	2.22	2.23
18°C	Capacity kW	8.27	8.10	7.98	7.60	7.34	6.76	6.40
	Input kW.	2.11	2.16	2.21	2.23	2.24	2.26	2.27
20°C	Capacity kW	7.87	7.72	7.60	7.24	6.99	6.43	6.10
	Input kW.	2.33	2.21	2.25	2.27	2.28	2.31	2.32
22°C	Capacity kW	7.50	7.35	7.24	6.89	6.66	6.13	5.81
	Input kW.	2.20	2.25	2.30	2.32	2.33	2.35	2.37
27°C	Capacity kW	7.14	7.00	6.90	6.56	6.34	5.84	5.53
	Input kW.	2.25	2.30	2.34	2.37	2.38	2.40	2.41

**6.12 SECS036P3A**

MODEL		SECS036P3A						
HEATING		OUTDOOR CONDITIONS						
Indoor Conditions		24°C DB 18°C WB	12°C DB 11°C WB	7°C DB 6°C WB	4°C DB 3°C WB	0°C DB -1°C WB	-5°C DB -6°C WB	-7°C DB -8°C WB
15°C	Capacity kW	13.01	12.76	12.57	11.96	11.56	10.64	10.08
	Input kW.	3.47	3.55	3.61	3.65	3.67	3.70	3.72
18°C	Capacity kW	12.40	12.15	11.97	11.39	11.01	10.13	9.60
	Input kW.	3.53	3.62	3.69	3.72	3.74	3.78	3.80
20°C	Capacity kW	11.81	11.57	11.40	10.85	10.49	9.65	9.14
	Input kW.	3.89	3.70	3.76	3.80	3.82	3.85	3.87
22°C	Capacity kW	11.24	11.02	10.86	10.34	9.98	9.19	8.71
	Input kW.	3.67	3.77	3.84	3.87	3.90	3.93	3.95
27°C	Capacity kW	10.71	10.49	10.34	9.84	9.51	8.75	8.30
	Input kW.	3.75	3.85	3.91	3.95	3.97	4.01	4.03

### 6.13 SECS048P3A

MODEL		SECS048P3A						
HEATING		OUTDOOR CONDITIONS						
Indoor Conditions		24°C DB 18°C WB	12°C DB 11°C WB	7°C DB 6°C WB	4°C DB 3°C WB	0°C DB -1°C WB	-5°C DB -6°C WB	-7°C DB -8°C WB
15°C	Capacity kW	17.35	17.01	16.76	15.95	15.41	14.18	13.44
	Input kW.	4.87	4.98	5.07	5.13	5.15	5.2	5.23
18°C	Capacity kW	16.53	16.2	15.96	15.19	14.68	13.51	12.8
	Input kW.	4.96	5.08	5.18	5.23	5.25	5.31	5.33
20°C	Capacity kW	15.74	15.43	15.2	14.47	13.98	12.86	12.19
	Input kW.	5.46	5.19	5.28	5.33	5.36	5.41	5.44
22°C	Capacity kW	14.99	14.69	14.48	13.78	13.31	12.25	11.61
	Input kW.	5.16	5.29	5.39	5.44	5.47	5.52	5.55
27°C	Capacity kW	14.28	13.99	13.79	13.12	12.68	11.67	11.06
	Input kW.	5.27	5.4	5.49	5.55	5.58	5.63	5.66

### 6.14 SECS060P3A

MODEL		SECS060P3A						
HEATING		OUTDOOR CONDITIONS						
Indoor Conditions		24°C DB 18°C WB	12°C DB 11°C WB	7°C DB 6°C WB	4°C DB 3°C WB	0°C DB -1°C WB	-5°C DB -6°C WB	-7°C DB -8°C WB
15°C	Capacity kW	19.83	19.44	19.15	18.23	17.61	16.21	15.36
	Input kW.	5.52	5.64	5.74	5.81	5.83	5.89	5.92
18°C	Capacity kW	18.89	18.51	18.24	17.36	16.78	15.44	14.63
	Input kW.	5.62	5.75	5.87	5.92	5.95	6.01	6.04
20°C	Capacity kW	17.99	17.63	17.37	16.54	15.98	14.70	13.93
	Input kW.	6.18	5.88	5.98	6.04	6.07	6.13	6.16
22°C	Capacity kW	17.13	16.79	16.55	15.75	15.21	14.00	13.27
	Input kW.	5.84	5.99	6.10	6.16	6.20	6.25	6.29
27°C	Capacity kW	16.32	15.99	15.76	14.99	14.49	13.34	12.64
	Input kW.	5.97	6.12	6.22	6.29	6.32	6.38	6.41

## 7. Electric Characteristics

Model	Indoor Units				Indoor Fan Motor
	Hz	Voltage	Min.	Max.	kW
<b>SECM012P3A</b>	50	220-240V	198V	254V	0.075
<b>SECM018P3A</b>	50	220-240V	198V	254V	0.075
<b>SECS018P3A</b>	50	220-240V	198V	254V	0.065
<b>SECS024P3A</b>	50	220-240V	198V	254V	0.15
<b>SECS036P3A</b>	50	220-240V	198V	254V	0.16
<b>SECS048P3A</b>	50	220-240V	198V	254V	0.18
<b>SECS060P3A</b>	50	220-240V	198V	254V	0.18



## 8.Sound Levels

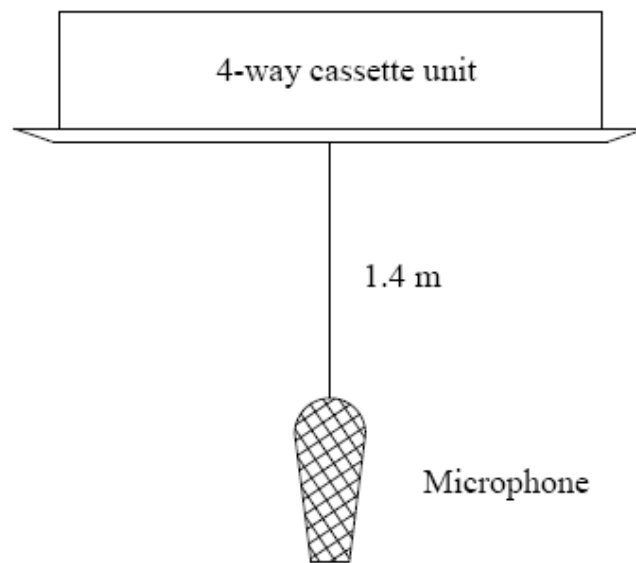

Model		SECM012P3A	SECM018P3A	SECS018P3A	SECS024P3A
Noise Level	dB (A)	40~45	43~48	38~45	44~48
Model		SECS036P3A	SECS048P3A	SECS060P3A	/
Noise Level	dB (A)	44~48	45~52	45~52	/

# 9. Exploded View

## 9.1 SECM012P3A, SECM018P3A

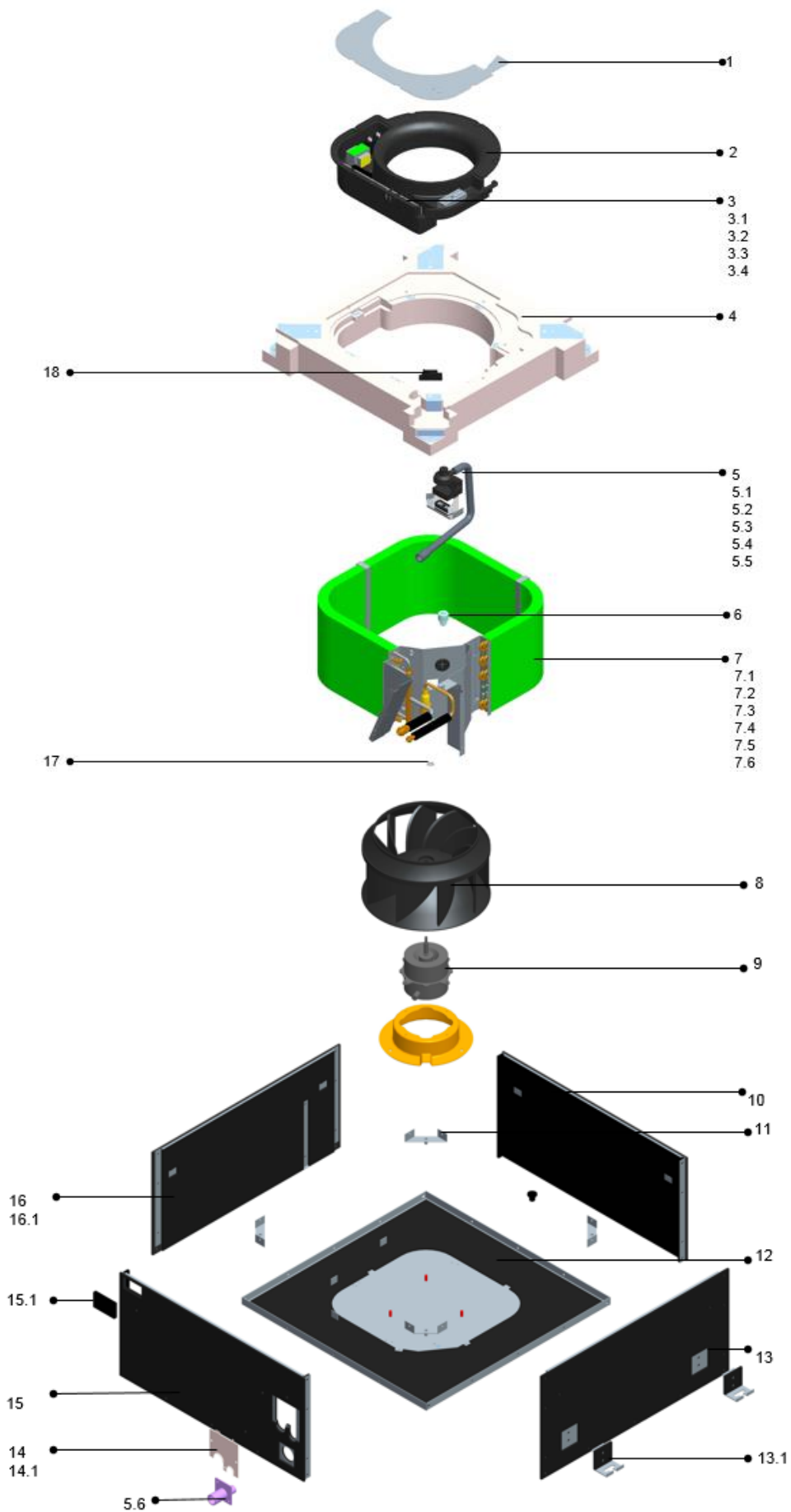

No.	Part Name	Quantity	No.	Part Name	Quantity
1	E-parts box cover assy	1	7.3	Inclined end-plate assy	1
2	E-parts box	1	7.4	Evaporator compacting bar assy	2
3	E-parts assy	1	7.5	Evaporator subassembly	1
3.1	Temperature sensor	1	8	Centrifugal fan	1
3.2	Temperature sensor	1	9	Indoor fan motor	1
3.3	PTC transformer	1	10	Brattice IV components	1
3.4	Terminal	1	11	Brattice fixing bar components	4
3.5	Electric control board assy	1	12	Chassis components	1
4	Foam water pan assy(ROHS)	1	12.1	Chassis welding components	1
5	Water pump components	1	13	Brattice I components	1
5.1	Water pump fixing plate assy	1	13.1	Shackle	2
5.2	Water outlet pipe	1	14	Copper tube support panel components	1
5.3	Water pump	1	14.1	Copper tube support panel	1
5.4	Water pump gasket 2	1	15	Brattice II components	1
5.5	Water pump gasket 1 components(ROHS)	1	15.1	Protection rubber	1
5.6	Discharge joint pipe assy(ROHS)	1	16	BratticeIIIcomponents	1
6	Water level switch	1	16.1	Shackle	2
7	Evaporator components	1	17	Fan gasket	1
7.1	End-plate II fixing plate assy	1	18	Groove clamp assy	1
7.2	End-plate I fixing plate assy	1			

### 9.2 SECS018P3A, SECS024P3A

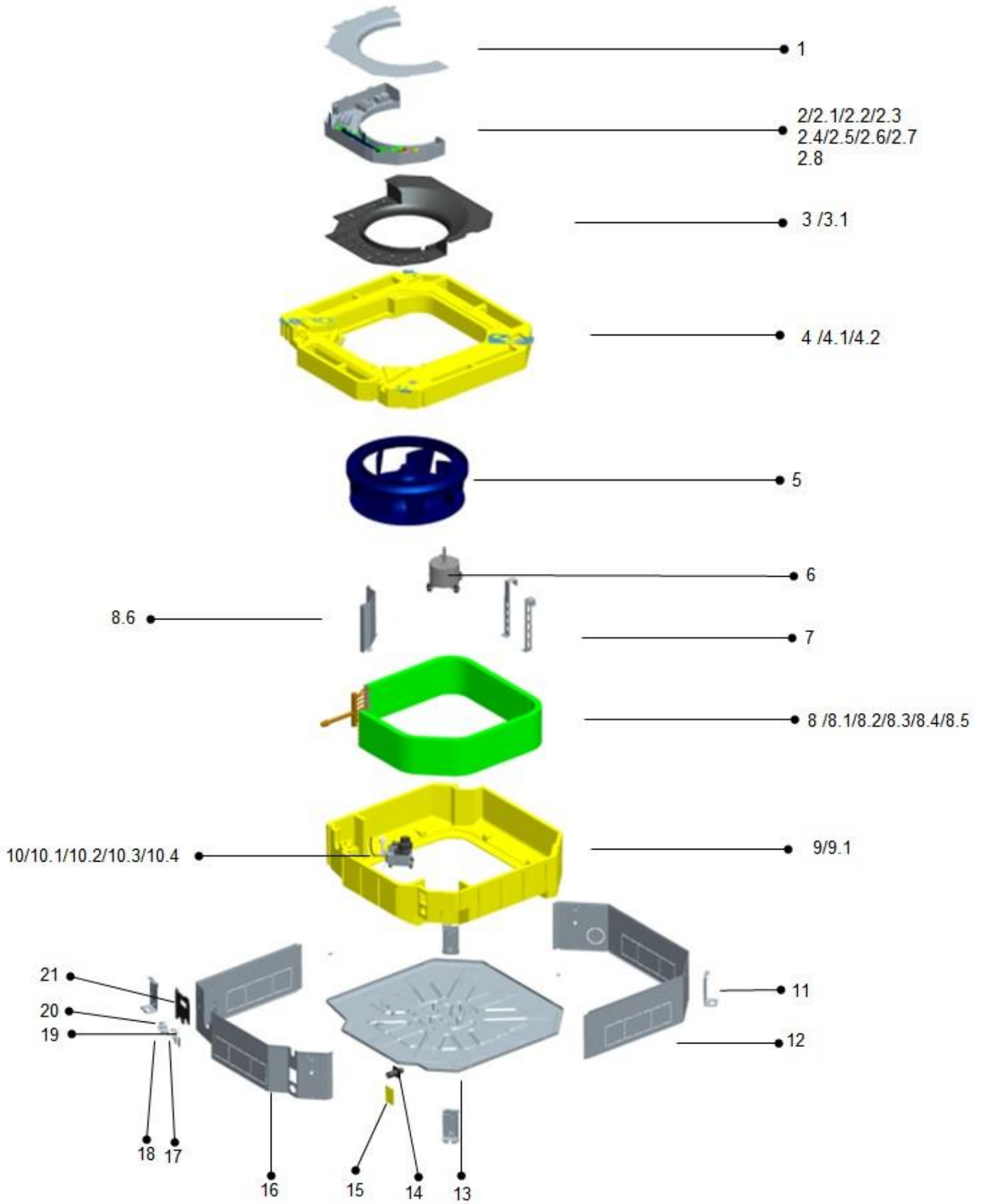





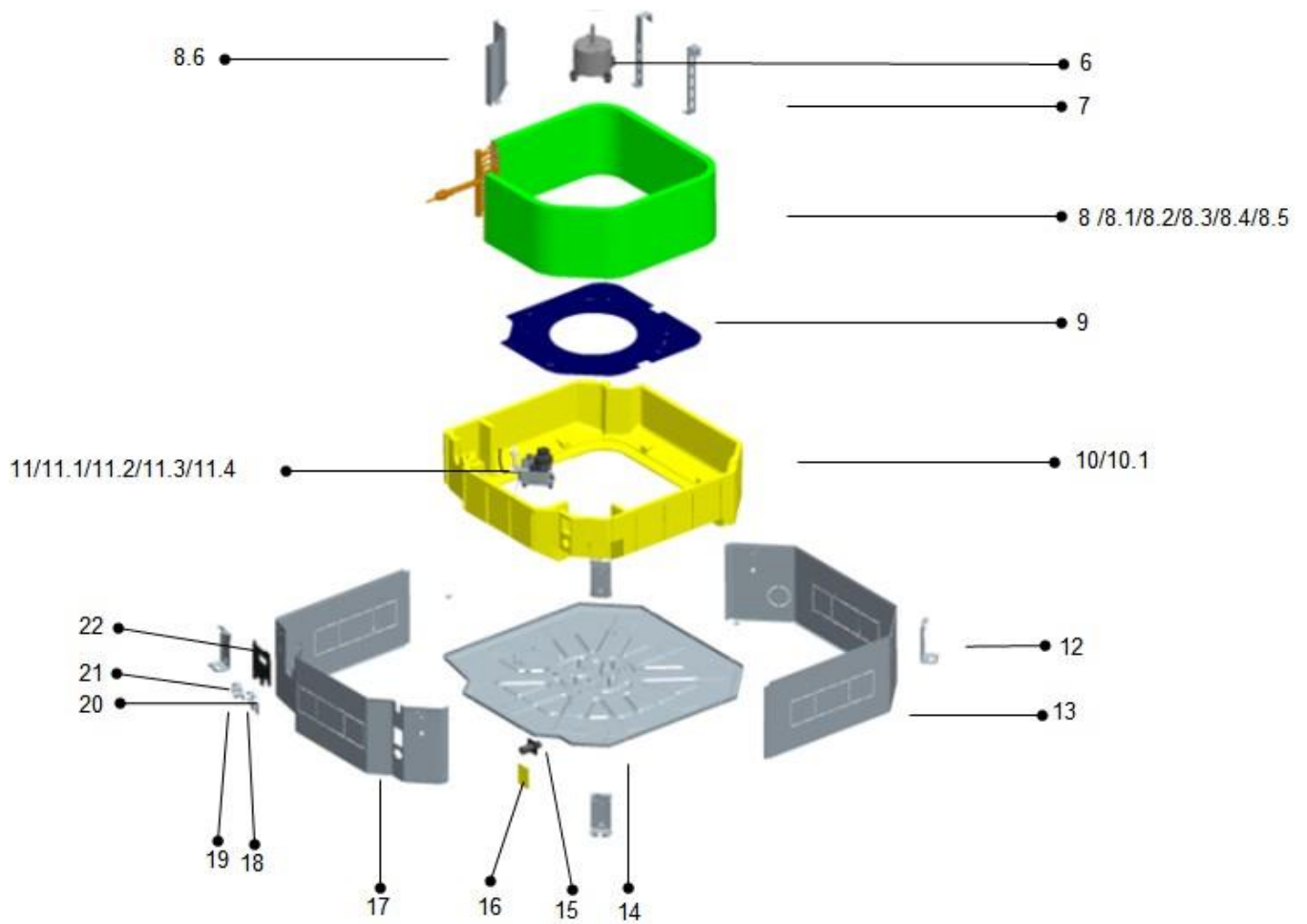





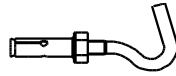

No.	Part Name	Quantity	No.	Part Name	Quantity
1	E-box cover	1	8.4.1	Installation tube for probe	1
2	Electric control components for indoor unit	1	8.4.2	Evaporator	1
2.1	Transformer	1	8.4.3	Collecting assy for evaporator	1
2.2	Fan motor capacitor	1	8.4.4	Shunt capillary assy	1
2.3	Terminal	1	8.5	Main fixing board	1
2.4	Terminal	1	9	Upper foam components	1
2.5	Electric control board for indoor unit	1	9.1	Upper foam	1
2.6	Temperature sensor	1	10	Pre-assembling assy for water pump	1
2.7	Temperature sensor	1	10.1	water pump support	1
2.8	Welded chassis for E-box	1	10.2	Water pump	1
3	Wind inlet guide assy	1	10.3	Liquid-level sensor	1
3.1	Wind inlet guide	1	10.4	Underlay for water pump support	3
4	Water pan components	1	11	Hanger	4
4.1	Water pan	1	12	Rear brattice	1
4.2	Water pan foam	2	13	Chassis assy	1
5	Centrifugal fan	1	14	Discharge pipe joint	1
6	Fan motor for indoor unit(YDK-75Q-6P3-1)	1	15	Side maintenance board for water pump	1
7	Auxiliary fixing board for evaporator	2	16	Front brattice	1
8	Evaporator components	1	17	Lower tube clamp	1
8.1	Insulating pipe	1	18	φ35 Lower tube clamp	1
8.2	Insulating pipe	1	19	Upper tube clamp	1
8.3	Evaporator attached cotton	1	20	φ35 Upper tube clamp	1
8.4	Evaporator welding assy	1	21	Valve plate	1

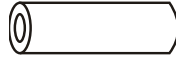
### 9.3 SECS036P3A,SECS048P3A,SECS060P3A

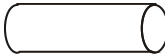

No.	Part Name	Quantity	No.	Part Name	Quantity
1	E-box cover	1	8.4.1	Installation tube for probe	1
2	Electric control components for indoor unit	1	8.4.2	Evaporator	1
2.1	Transformer	1	8.4.3	Collecting assy for evaporator	1
2.2	Fan motor capacitor	1	8.4.4	Shunt capillary assy	1
2.3	Terminal	1	8.5	Main fixing board	1
2.4	Terminal	1	9	Chassis plate	1
2.5	Electric control board for indoor unit	1	10	Upper foam components	1
2.6	Temperature sensor	1	10.1	Upper foam	1
2.7	Temperature sensor	1	11	Pre-assembling assy for water pump	1
2.8	Welded chassis for E-box	1	11.1	water pump support	1
3	Wind inlet guide assy	1	11.2	Water pump	1
3.1	Wind inlet guide	1	11.3	Liquid-level sensor	1
4	Water pan components	1	11.4	Underlay for water pump support	3
4.1	Water pan	1	12	Hanger	4
4.2	Water pan foam	2	13	Rear brattice	1
5	Centrifugal fan	1	14	Chassis assy	1
6	Fan motor for indoor unit(YDK-75Q-6P3-1)	1	15	Discharge pipe joint	1
7	Auxiliary fixing board for evaporator	2	16	Side maintenance board for water pump	1
8	Evaporator components	1	17	Front brattice	1
8.1	Insulating pipe	1	18	Lower tube clamp	1
8.2	Insulating pipe	1	19	φ35 Lower tube clamp	1
8.3	Evaporator attached cotton	1	20	Upper tube clamp	1
8.4	Evaporator welding assy	1	21	φ35 Upper tube clamp	1
			22	Valve plate	1

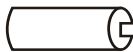
## 10.Accessories

	Name	Shape	Quantity
Installation Fittings	Expansible hook		4
	Installation hook		4
	Installation paper board		1
	Bolt M5		4
Tubing & Fittings (optional)	Connecting pipe group		1
	Binding tape		1
	Soundproof/insulation sheath		2
Drainpipe Fittings	Out-let pipe sheath		1
	Tightening band		5
Protect Pipe Fittings (optional)	Wall conduit		1
	Wall conduit cover		1
Remote controller	Remote controller		1
	Mounting screw(ST2.9×10-C-H)		2
	Alkaline dry batteries (AM4)		2
Others	Operation & installation instruction manual		1



## 11. The Specification of Wiring

Model		12kBtu/h	18kBtu/h	24kBtu/h	36kBtu/h
Indoor power supply	V/Ph/Hz	220~240/1/50			
Outdoor power supply	V/Ph/Hz	220~240/1/50			
Connection wiring	Outdoor Power Supply	From indoor unit	From indoor unit	Power supply individually for indoor and outdoor	
	Power wiring	mm <sup>2</sup>	3×1.5	3×2.5	3×2.5/3×1.0      3×4.0/3×1.0
	Signal wiring	mm <sup>2</sup>	5×1.5	5×1.5	RS485 twisted shielded wire pair 2×0.5

Model		36kBtu/h	48kBtu/h	60kBtu/h
Indoor power supply	V/Ph/Hz	220~240/1/50		
Outdoor power supply	V/Ph/Hz	380~415/3/50		
Connection wiring	Outdoor Power Supply	Power supply individually for indoor and outdoor		
	Power wiring	mm <sup>2</sup>	5×1.5/3×1.0	5×1.5/3×1.0      5×2.5/3×1.0
	Signal wiring	mm <sup>2</sup>	RS485 twisted shielded wire pair 2×0.5	

# 12.Field Wiring

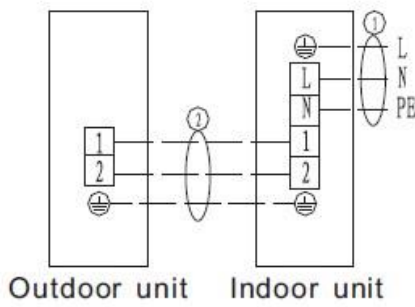

Outdoor unit Indoor unit

Applicable for 18K cooling only type

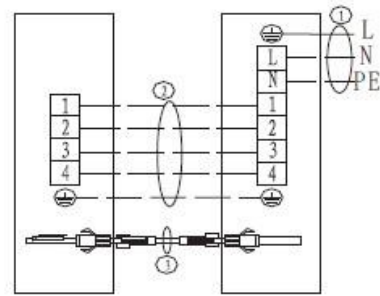

Outdoor unit Indoor unit

Applicable for 18K heatpump type

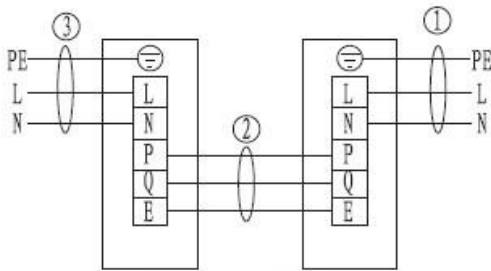

Outdoor unit Indoor unit

Applicable for 24K, 36K single-phase cooling and heatpump type

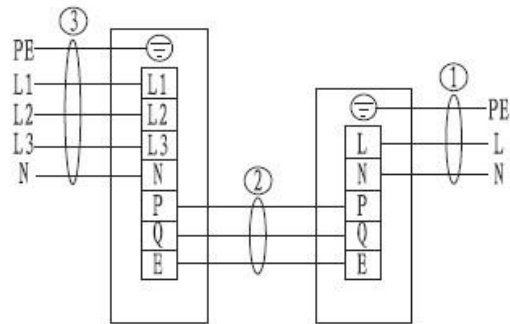

Outdoor unit Indoor unit

Applicable for 24K, 36K, 48K, 60K three-phase cooling and heatpump type

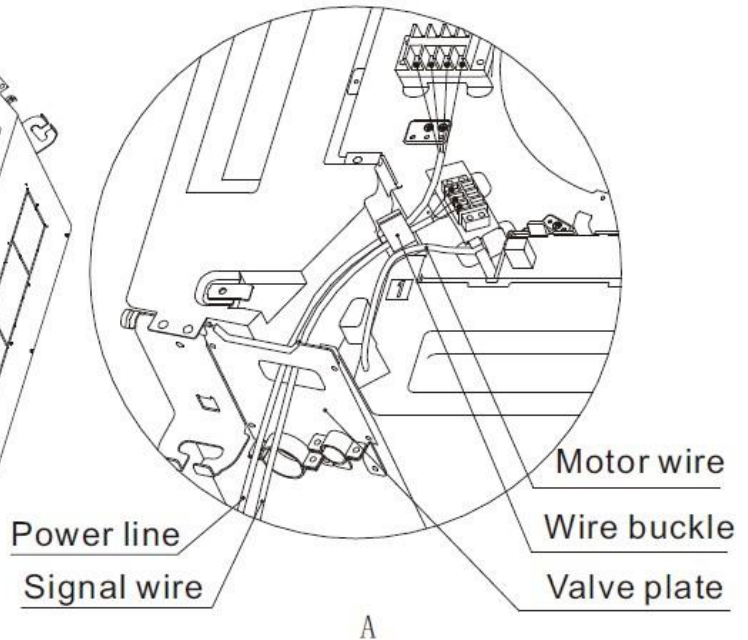
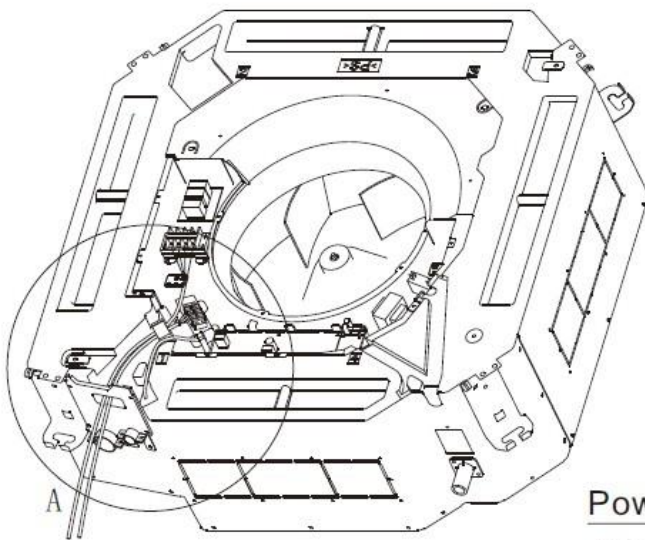

Note: The arrangement diagram is only for signal wire and power line. For wiring, please refer to power wiring diagram.

## 13.Troubleshooting

### Fault codes table

4LED Faults	Digital display	Failure description
Timer light flashing	E2	Ambient temperature sensor (T1) failure
Running light flashing	E3	Evaporator pipe temperature sensor (T2) failure
Defrost light flashing	E5	Condenser pipe temperature sensor (T3) failure
Warning light flashing	F5	Water full filled protection
Running light, defrost light flashing	E1	Indoor unit and wire controller communication failure
Running light, timer light flashing	P6	Indoor unit EEPROM failure
Defrost light, timer light flashing	F0	Indoor fan stall protection
Defrost light, warning light flashing	F2	Outdoor protection
	F7	Outdoor unit over-current protection
Timer light, warning light flashing	E0	Indoor unit and outdoor unit communication failure
Running light, defrost light, timer light flashing	F3	High pressure protection
Defrost light , timer light, warning light flashing	F4	Low pressure protection
Running light, timer light, warning light flashing	F8	Outdoor unit exhaust temperature over-high protection
Running light, defrost light, timer light, warning light flashing	F9	Three-phase electricity phase sequence failure
Note: the flashing frequency for all above indication lights is 1HZ.		

# Duct Type

1.Features .....	38
2.Specification .....	45
3.Dimensions .....	49
4.Service Space .....	52
5.Wiring Diagrams .....	53
6.Capacity Tables .....	58
7.Static Pressure .....	64
8.Electric Characteristics .....	68
9.Sound Levels .....	69
10.Accessories .....	70
11.The Specification of Wiring .....	71
12.Field Wiring .....	72
13.Exploded View .....	73
14.Troubleshooting .....	77

## 1. Features



**Low Static Pressure Duct**



**Medium Static Pressure Duct**



**High Static Pressure Duct**

## 1.1 Low ESP Ducted Unit

1. Ultra-thin body design.

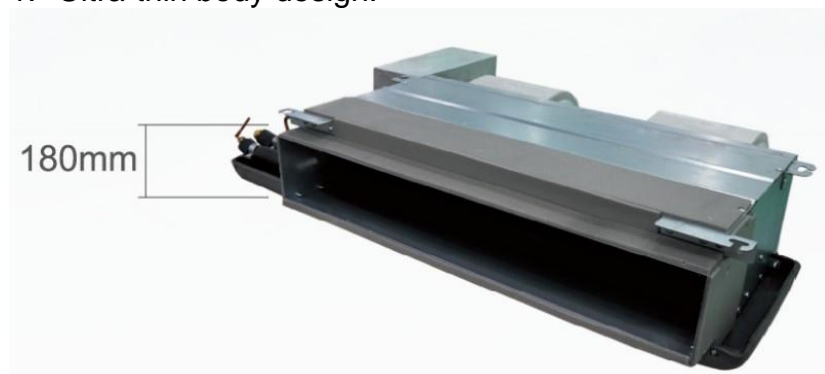

2. Adopting aviation centrifugal fans, and CFD technology design, increasing air-volume and decreasing noise level, noise level only 29dB(A).

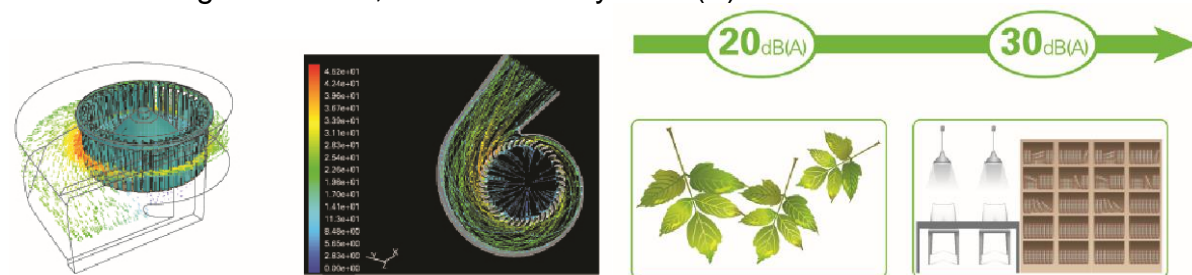

3. Three fan speed, meet different requirement.



4. Filter can be taken out easily for clear. Easy maintenance.
5. E-box is body-side design, convenient installation and maintenance.

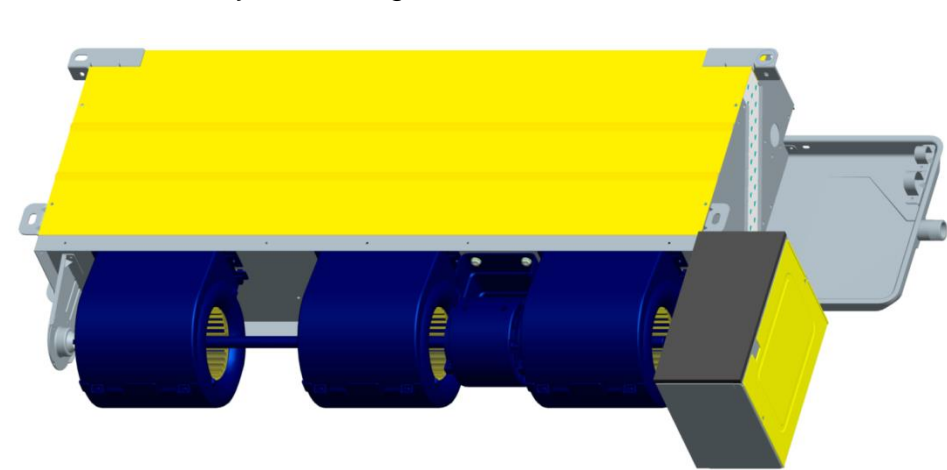

- Multi protection and auto-restart function.
- Standard for wired controller, wireless controller for option.



Standard



Optional

## 1.2 Medium ESP Ducted Unit

- Ultra-thin body design.



- Adopting aviation centrifugal fans, and CFD technology design, increasing air-volume and decreasing noise level.

- Three fan speed, meet different requirement.





- 30Pa ESP design for the medium static pressure duct type, duct connected installation meet for different room structure. 70pa is optional.

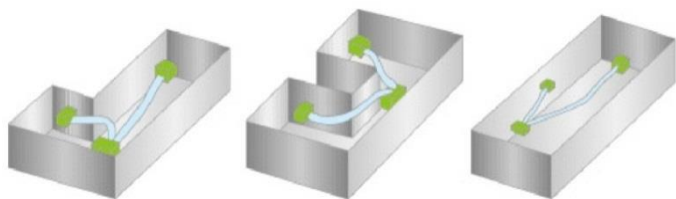

- Filter can be taken out easily for clear. Easy maintenance.



- E-box is body-side design, convenient installation and maintenance.



- Two air return type option: air inlet from back is standard and from bottom is optional

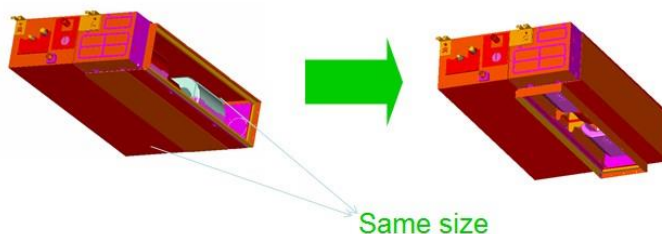

- Multi protection and auto-restart function.

- Standard for wired controller, wireless controller for option.



Standard



Optional



## 1.3 High ESP Ducted Unit

(1) Centrifugal fan, low noise and big airflow.

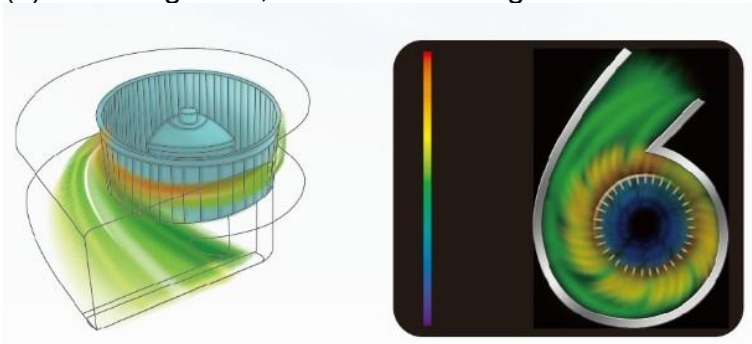

(2) 120Pa ESP design, flexible air duct installation.

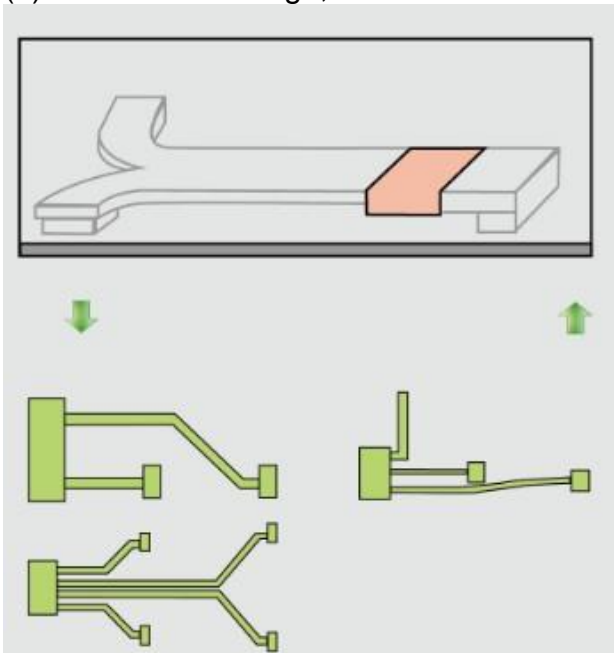

(3) Filter can be taken out easily for clear. Easy maintenance.

(4) Multi protection and auto-restart function.

(5) Standard for wired controller, wireless controller for option.



Standard



Optional

## 2.Specification

Model			SELP018P3A	SEMP018P3A	SELP024P3A
Indoor power supply		V/Ph/Hz	220~240V/1Ph/50Hz	220~240V/1Ph/50Hz	220~240V/1Ph/50Hz
Cooling	Capacity	Btu/h	18000	18000	24000
		KW	5.3	5.3	7.1
	Input	W	70	250	150
	Rated current	A	0.4	1.1	0.7
	EER	W/W	2.69	2.47	2.78
Heating	Capacity	Btu/h	20000	19800	26000
		KW	5.9	5.9	7.7
	Input	W	70	250	150
	Rated current	A	0.4	1.1	0.7
	COP	W/W	3.35	3.04	3.42
Indoor fan motor	Model		YSK110-35P-4P3H95 -1	YSK110-90F-4P3H10 5	YSK-110-50P-4P3H9 5-1
	Input	W	70	250	150
	Capacitor	μF	1.8	5	3
	Speed(Hi/Me/Lo)	r/min	1320/1220/1020/850	1100/940/850/800	1170/970/810/710
Indoor coil	Number of rows		3	2	3
	Fin spacing	mm	1.6	1.7	1.6
	Fin type		Hydrophilic	Hydrophilic	Hydrophilic
	Number of circuits		4	6	5
Indoor air flow(High speed)		m <sup>3</sup> /h	730	900	1150
Static Pressure		Pa	0-20	30-70	0-20
Indoor noise level		dB(A)	37~46	40~48	38~48
Indoor unit	Dimension(W*H*D)	Body(mm)	1204×181×560	1189×260×643	1532×181×510
	Packing(W*H*D)	Body(mm)	1310×250×645	1255×325×720	1625×250×645
	Net/Gross weight	Body(Kg)	20/24	32/36	24/27.5
Max pressure		MPa	4.0	4.0	4.0
Refrigerant type			R410A	R410A	R410A
Refrigerant piping	Liquid side/Gas side	mm	Φ6.35/Φ12.7	Φ9.52/Φ15.88	Φ9.52/Φ15.88
Drainage pipe		mm	DN25	DN25	DN25
Controller			Standard for wired controller(remote controller for option)		
Operation temp		°C	16~32	16~32	16~32
Ambient temp		°C	-7~43	-7~43	-7~43
Application area		m <sup>2</sup>	20-35	20-35	28~50
Stuffing Quantity(20'/40'/40'HQ)		set	115/250/320	75/165/189	90/190/255

**Notes:**

1. Nominal cooling capacities are based on the following conditions:

Indoor temp: 27°CDB, 19°CWB; Outdoor temp: 35°CDB; Equivalent ref. Piping: 5m(horizontal)

2. Nominal heating capacities are based on the following conditions:

Indoor temp: 20°CDB; Outdoor temp: 7°CDB, 6°CWB; Equivalent ref. Piping: 5m(horizontal)

3. Actual noise level may differ, depending on the room structure, etc, since these noise values are from an anechoic room.

Model		SEMP024P3A	SEMP036P3A	SEMP048P3A	
Indoor power supply		V/Ph/Hz	220~240V/1Ph/50Hz	220~240V/1Ph/50Hz	
Cooling	Capacity	Btu/h	24000	36000	
		KW	7.1	10.5	
	Input	W	250	300	
	Rated current	A	1.1	1.4	
EER	W/W	2.68	2.56	2.62	
Heating	Capacity	Btu/h	26000	39000	
		KW	7.7	11.5	
	Input	W	250	300	
	Rated current	A	1.1	1.4	
COP	W/W	3.28	2.95	2.79	
Indoor fan motor	Model		YSK110-90F-4P3H105	YDK110-75F-4P3H105 L-1 +YSK120-150F-4P3H105-1	YDK110-75F-4P3H105L +YSK120-150F-4P3H105
	Input	W	250	300	340
	Capacitor	μF	5	3+5	3+5
	Speed(Hi/Me/Lo)	r/min	1100/940/850/800	1310/1170/1090/1040 +1300/1200/1110/1060	1340/1270/1200/1130 +1340/1240/1140/1040
Indoor coil	Number of rows		3	3	3
	Fin spacing	mm	1.7	1.7	1.8
	Fin type		Hydrophilic	Hydrophilic	Hydrophilic
	Number of circuits		6	6	5
Indoor air flow(High speed)		m <sup>3</sup> /h	1200	1900	2000
Static Pressure		Pa	30-70	30-70	30-70
Indoor noise level		dB(A)	40~48	40~50	40~50
Indoor unit	Dimension (W*H*D)	Body(mm)	1189×260×643	1425×260×643	1425×260×643
	Packing (W*H*D)	Body(mm)	1255×325×720	1490×325×720	1490×325×720
	Net/Gross weight	Body(Kg)	33/37	44/48	44/48
Max pressure		MPa	4.0	4.0	4.5
Refrigerant type			R410A	R410A	R410A
Refrigerant piping	Liquid side/Gas side	mm	Φ9.52/Φ15.88	Φ9.52/Φ19.05	Φ9.52/Φ19.05
Drainage pipe		mm	DN25	DN25	DN25
Controller		Standard for wired controller(remote controller for option)			

Operation temp	°C	16~32	16~32	16~32
Ambient temp	°C	-7~43	-7~43	-7~43
Application area	m <sup>2</sup>	28-50	40-70	55~95
Stuffing Quantity(20'/40'/40'HQ)	set	75/165/189	75/165/168	75/165/168

**Notes:**

1. Nominal cooling capacities are based on the following conditions:

Indoor temp: 27°CDB, 19°CWB; Outdoor temp: 35°CDB; Equivalent ref. Piping: 5m(horizontal)

2. Nominal heating capacities are based on the following conditions:

Indoor temp: 20°CDB; Outdoor temp: 7°CDB, 6°CWB; Equivalent ref. Piping: 5m(horizontal)

3. Actual noise level may differ, depending on the room structure, etc, since these noise values are from an anechoic room.

Model			SEMP060P3A	SEHP048P3A	SEHP060P3A
Indoor power supply		V/Ph/Hz	220~240V/1Ph/50Hz	220~240V/1Ph/50Hz	220~240V/1Ph/50Hz
Cooling	Capacity	Btu/h	60000	48000	60000
		KW	16.0	14	16
	Input	W	340	500	500
	Rated current	A	1.6	2.3	2.3
	EER	W/W	2.65	2.55	2.58
Heating	Capacity	Btu/h	60000	52500	60000
		KW	16.0	15.2	16.0
	Input	W	340	500	500
	Rated current	A	1.6	2.3	2.3
	COP	W/W	2.61	2.71	2.54
Indoor fan motor	Model		YDK110-75F-4P3H105 L +YSK120-150F-4P3H1 05	YSK139-300F-4P3H9 5	YSK139-300F-4P3H9 5
	Input	W	340	500	500
	Capacitor	μF	3+5	15	15
	Speed(Hi/Me/Lo )	r/min	1340/1270/1200/1130 +1340/1240/1140/1040	1050/830/720	1050/830/720
Indoor coil	Number of rows		3	3	3
	Fin spacing	mm	1.8	1.6	1.6
	Fin type		Hydrophilic	Hydrophilic	Hydrophilic
	Number of circuits		5	6	6
Indoor air flow(High speed)		m <sup>3</sup> /h	2000	2300	2300
Static Pressure		Pa	30-70	120	120
Indoor noise level		dB(A)	40~50	44~52	44~52
Indoor unit	Dimension (W*H*D)	Body(mm)	1425x643x260	1175x610x370	1175x610x370
	Packing (W*H*D)	Body(mm)	1490x720x325	1245x655x445	1245x655x445
	Net/Gross weight	Body(Kg)	44/48	45/49	45/49

Max pressure		MPa	4.5	4.0	4.0
Refrigerant type			R410A	R410A	R410A
Refrigerant piping	Liquid side/Gas side	mm	Φ9.52/Φ19.05	Φ9.52/Φ19.05	Φ9.52/Φ19.05
Drainage pipe		mm	25	25	25
Controller			Standard for wired controller(remote controller for option)		
Operation temp		°C	16~32	16~32	16~32
Ambient temp		°C	-7~43	-7~43	-7~43
Application area		m <sup>2</sup>	60~105	55~95	60~105
Stuffing Quantity(20'/40'/40'HQ)		set	75/165/168	75/165/168	75/165/168

**Notes:**

1. Nominal cooling capacities are based on the following conditions:

Indoor temp: 27°CDB, 19°CWB; Outdoor temp: 35°CDB; Equivalent ref. Piping: 5m(horizontal)

2. Nominal heating capacities are based on the following conditions:

Indoor temp: 20°CDB; Outdoor temp: 7°CDB, 6°CWB; Equivalent ref. Piping: 5m(horizontal)

3. Actual noise level may differ, depending on the room structure, etc, since these noise values are from an anechoic room.

### 3. Dimensions

#### 3.1 SELP018P3A

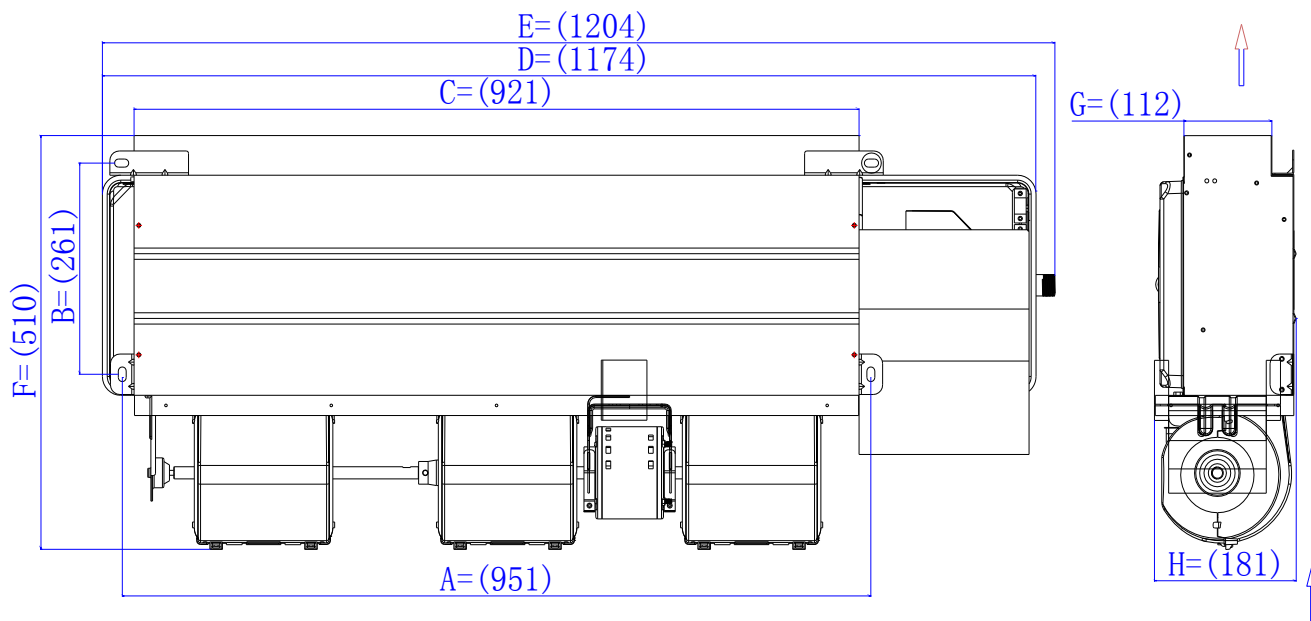

#### 3.2 SELP024P3A

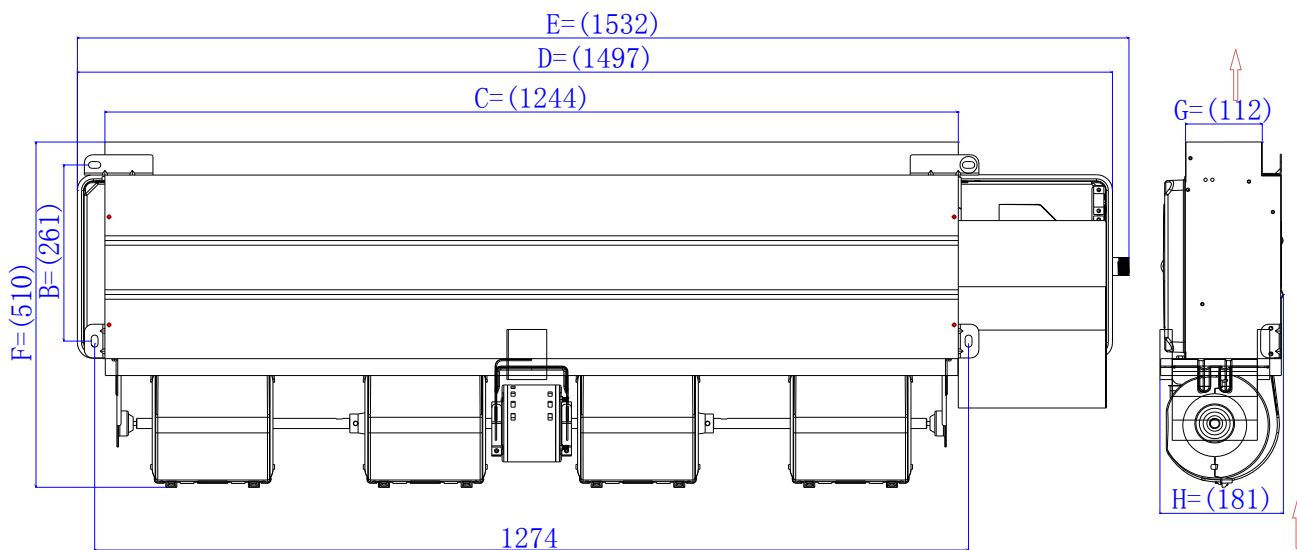

### 3.3 SELP018P3A, SELP024P3A

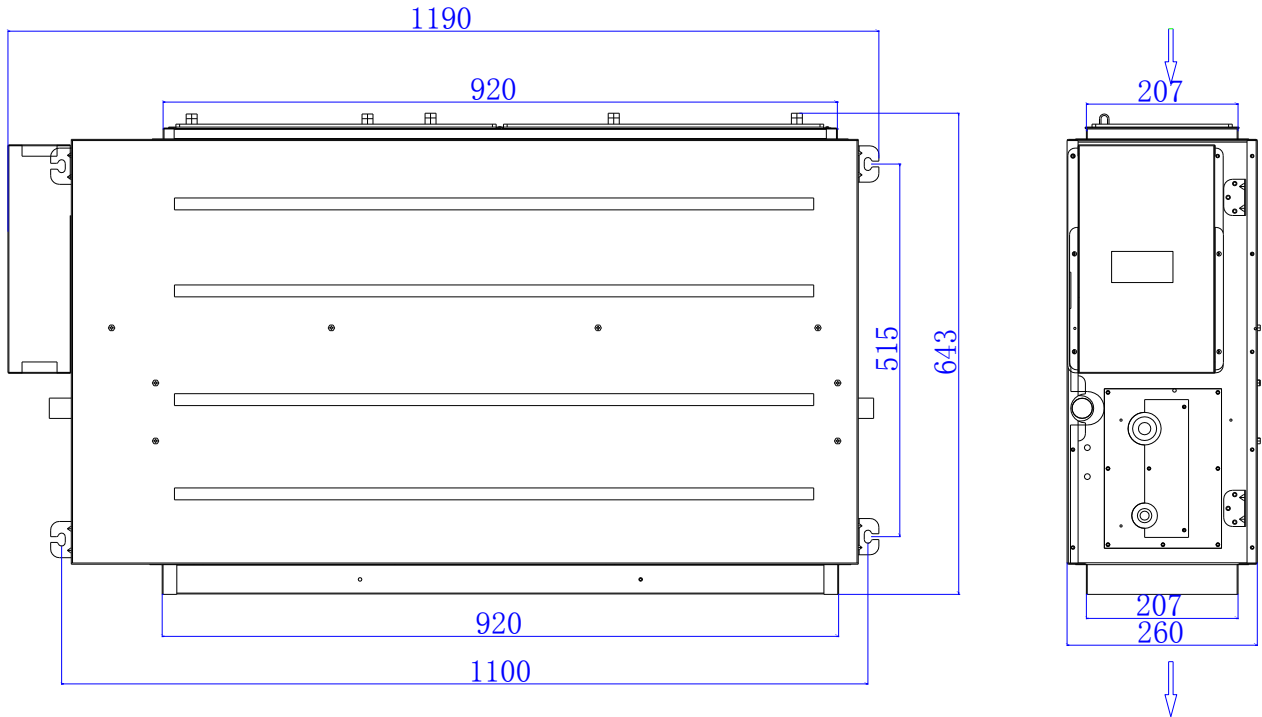

### 3.4 SELP036P3A, SELP048P3A, SELP060P3A

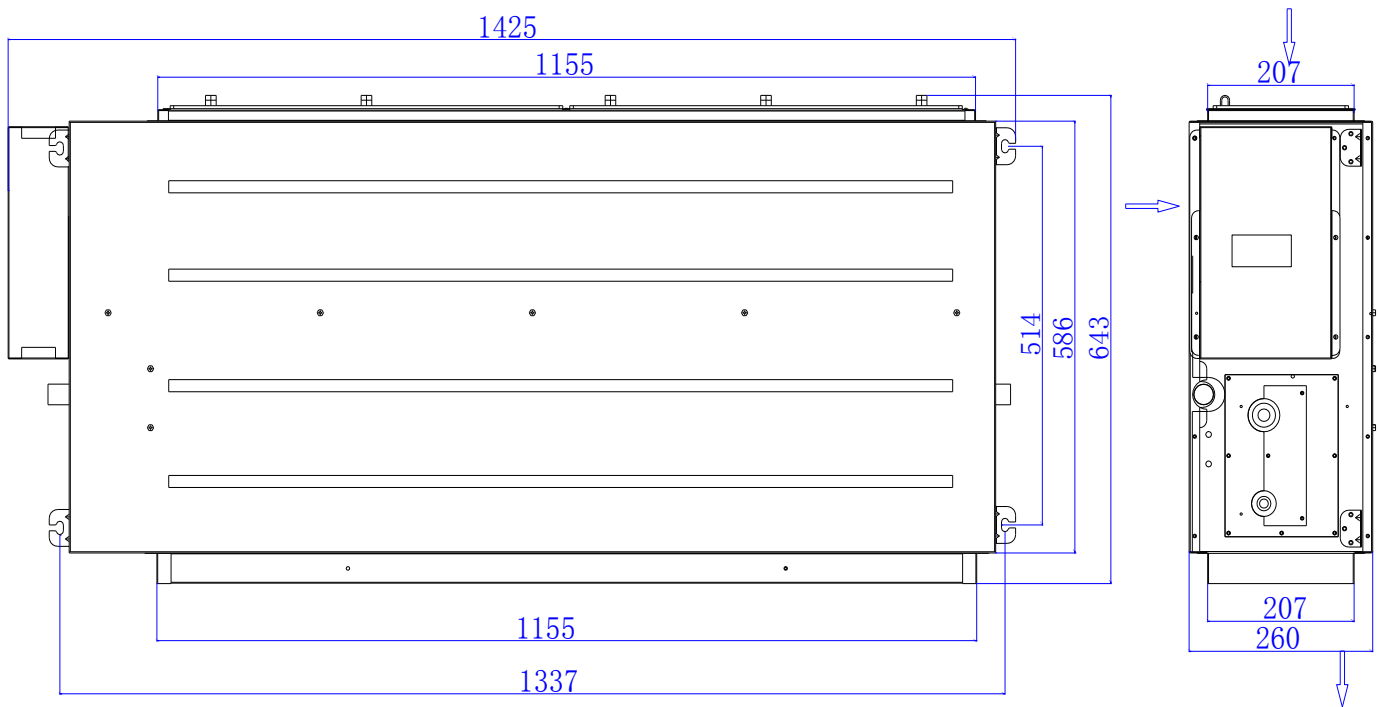

### 3.5 SEHP048P3A, SEHP060P3A

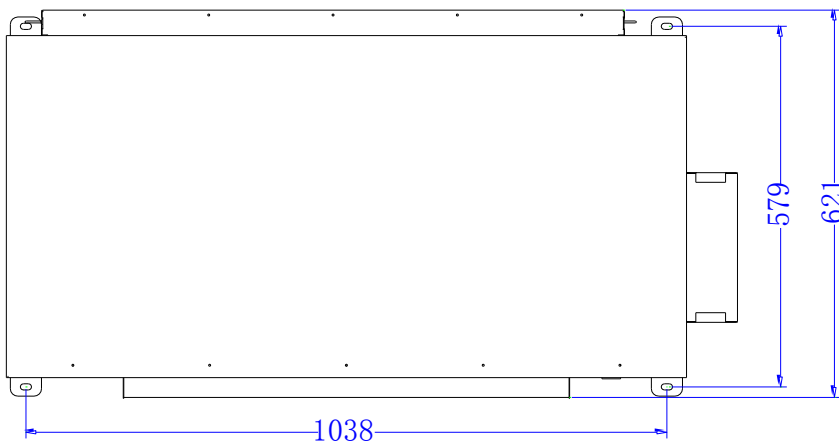
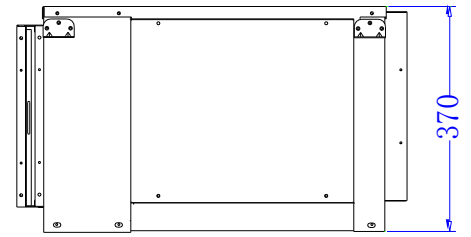
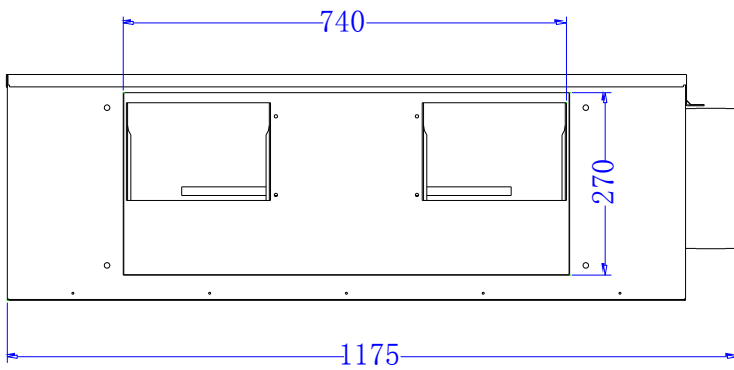



## 4. Service Space

Ensure enough space required for installation and maintenance.

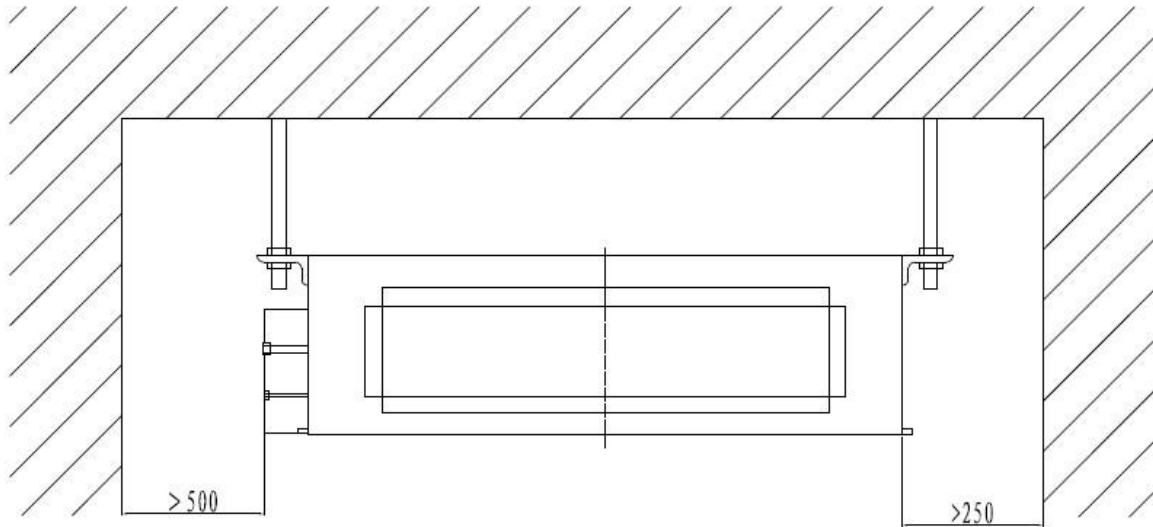

# 5.Wiring Diagrams

## 5.1 SELP018P3A

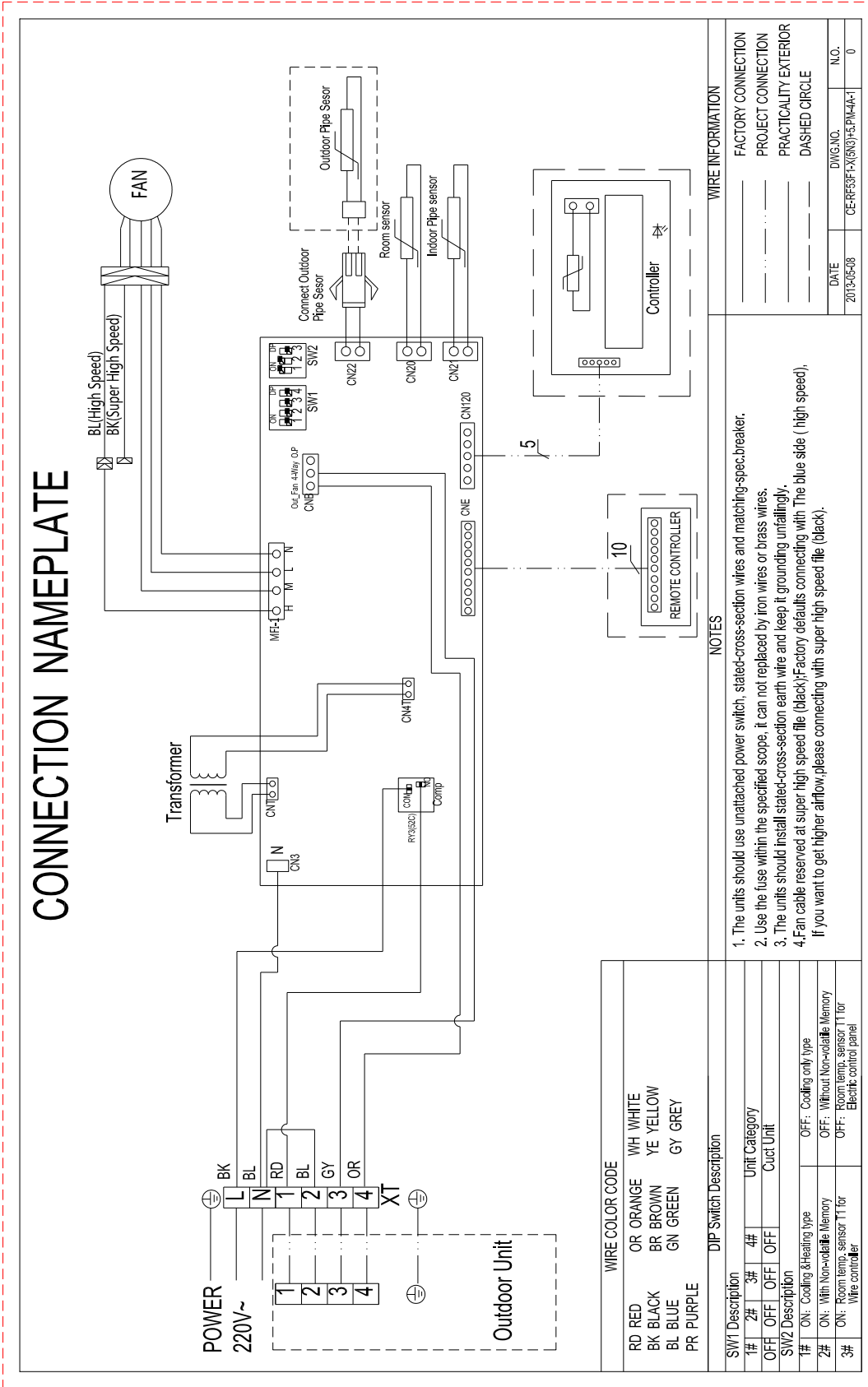

# 5.2 SEMP018P3A

## CONNECTION NAMEPLATE

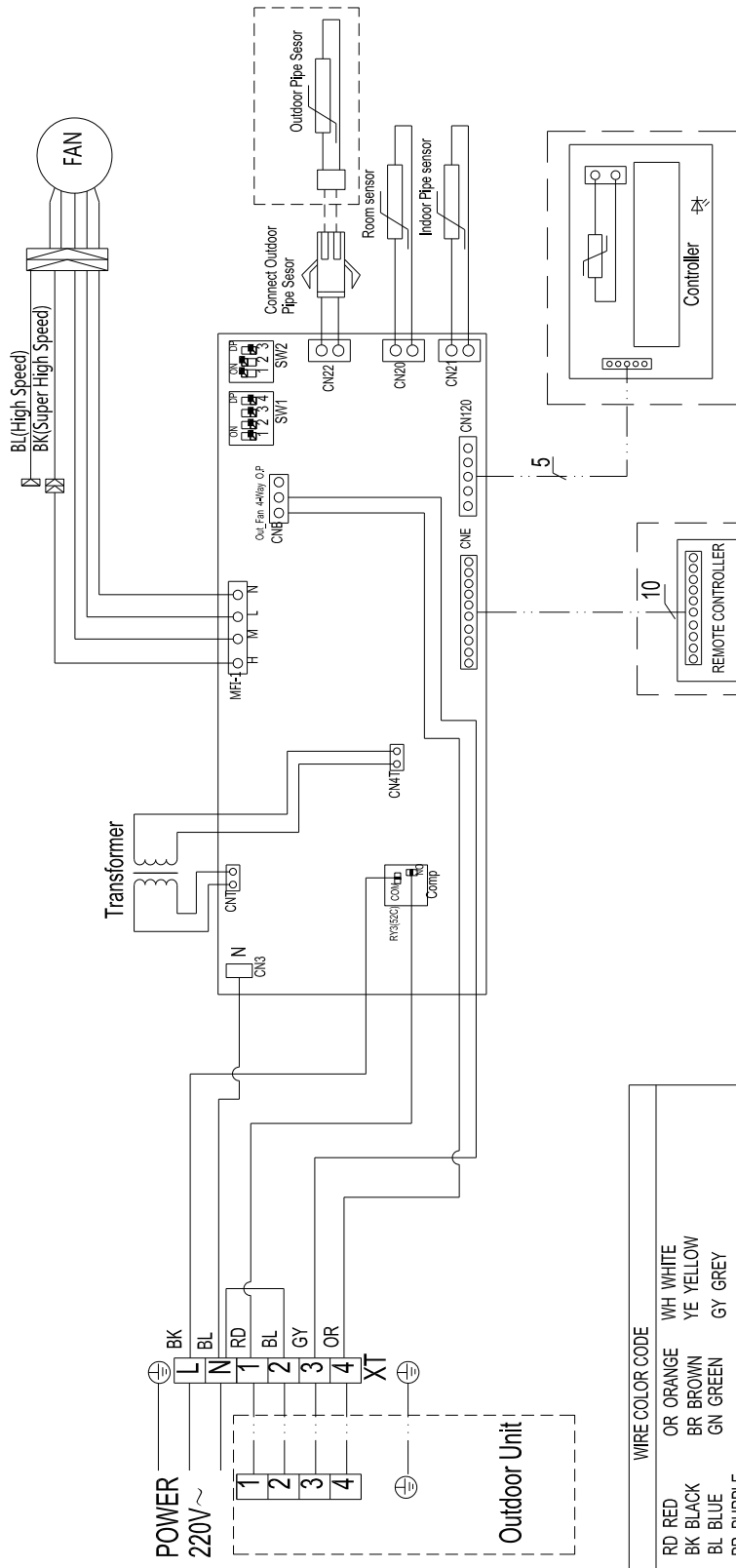

WIRE COLOR CODE	
RD RED	OR ORANGE WH WHITE
BK BLACK	BR BROWN YE YELLOW
BL BLUE	GN GREEN GY GREY
PR PURPLE	

DIP Switch Description	
SW1 Description	Unit Category
1# OFF	2# OFF
3# OFF	4# OFF
SW2 Description	Curt Unit
1# ON: Cooling & heating type	OFF: Cooling only type
2# ON: With Non-volatile Memory	OFF: Without Non-volatile Memory
3# ON: Room temp. sensor T1 for Wire controller	OFF: Room temp. sensor T1 for Electric control panel

**NOTES**

- The units should use unattached power switch, stated-cross-section wires and matching-spec. breaker.
- Use the fuse within the specified scope. It can not be replaced by iron wires or brass wires.
- The units should install stated-cross-section earth wire and keep it grounding unaltingly.
- Fan cable reserved at high speed file (blue); Factory defaults connecting with The black side (super high speed). If you want to get low airflow, please connecting with high speed file (blue).

**WIRE INFORMATION**

FACTORY CONNECTION	
PROJECT CONNECTION	
PRACTICALITY EXTERIOR	
DASHED CIRCLE	

DATE	DWG. NO.	I. NO.
2013-05-08	CE-RF28F-X(GN)-S,PM-4A-1	0

### 5.3 SELP024P3A

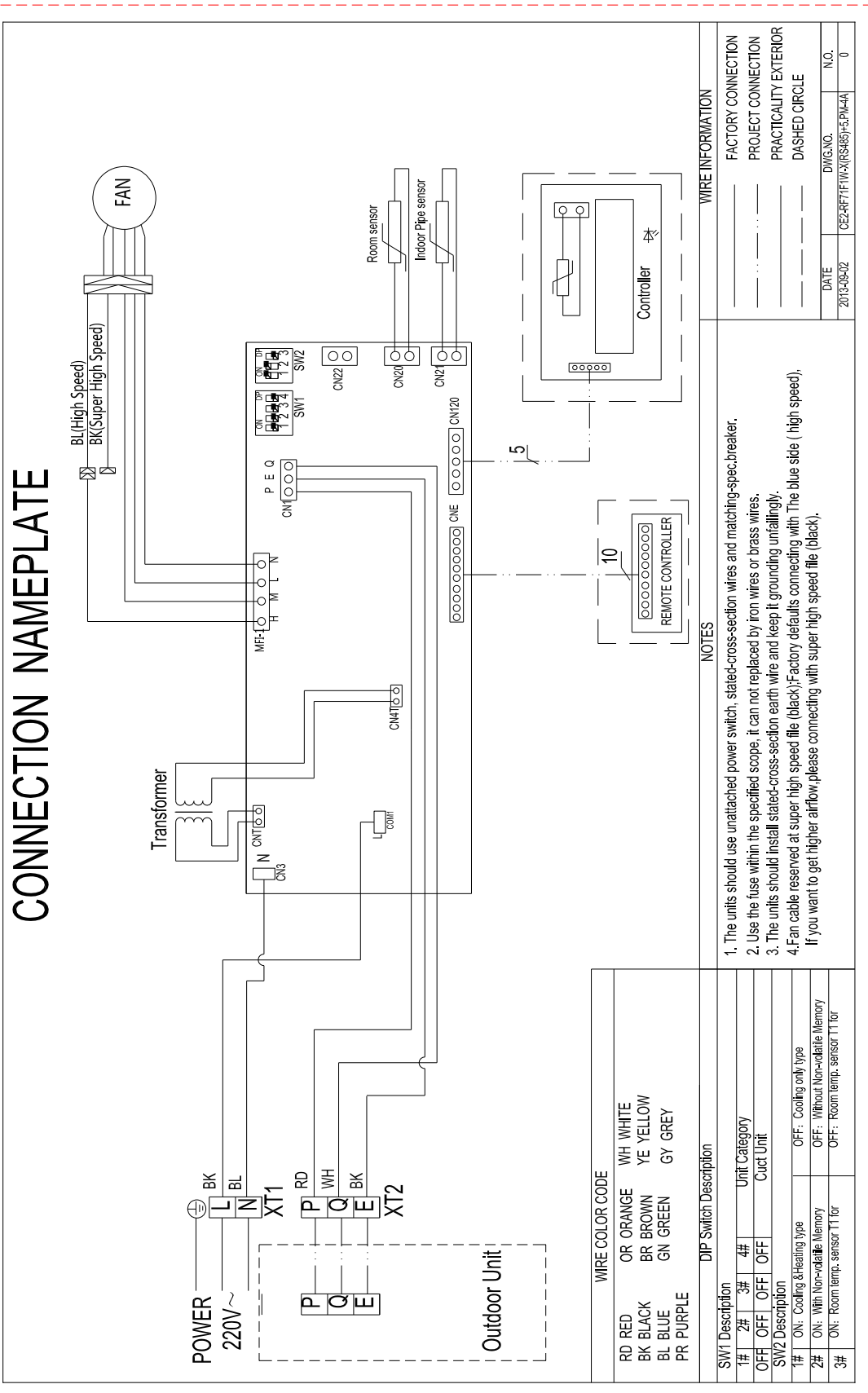

# 5.4 SEMP024P3A, SEMP036P3A, SEMP048P3A, SEMP060P3A

## CONNECTION NAMEPLATE

Notice 1: Units with only one fan, fan 2 Don't need wiring

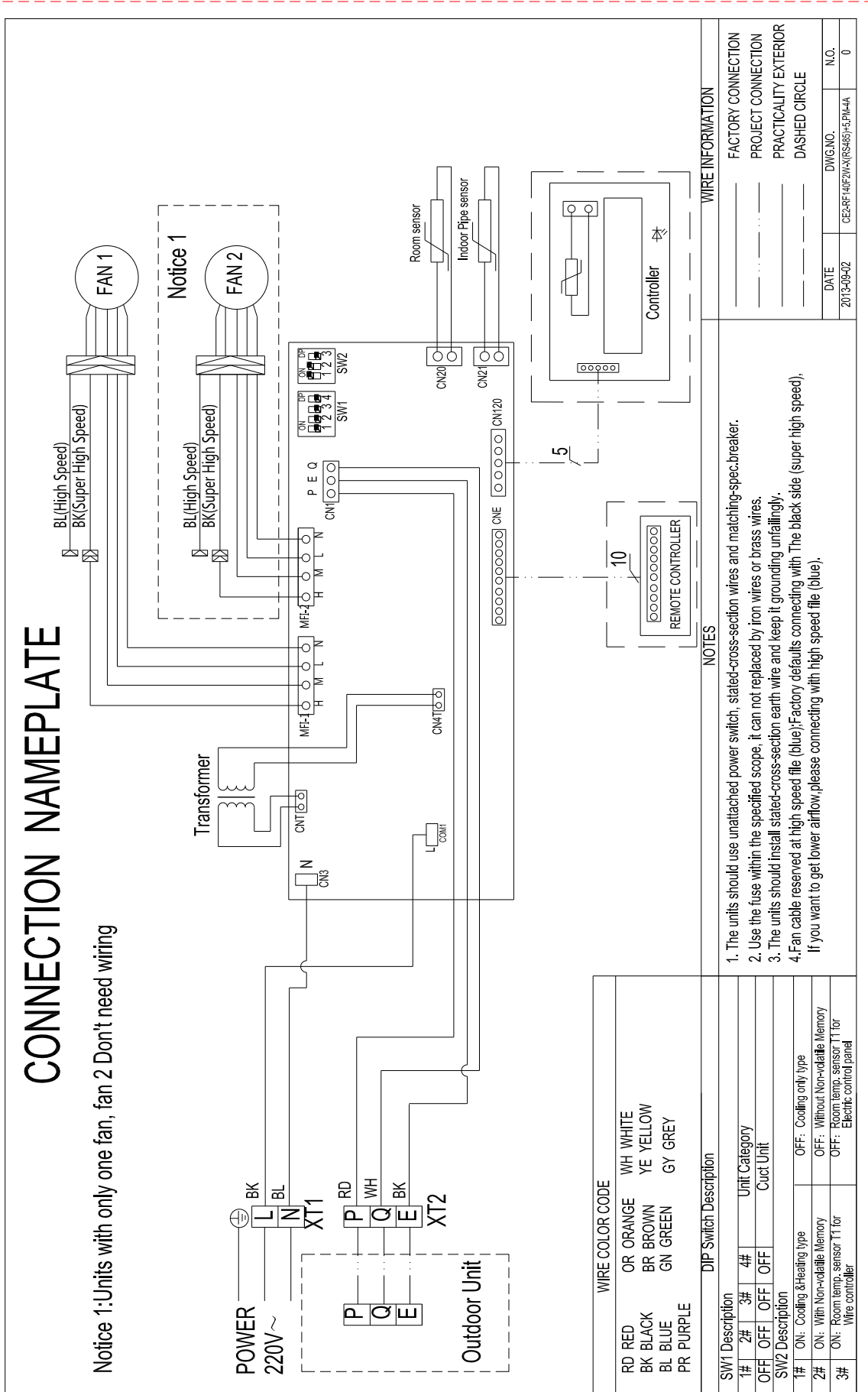

WIRE INFORMATION	
FACTORY CONNECTION	
PROJECT CONNECTION	
PRACTICALITY EXTERIOR	
DASHED CIRCLE	
DATE	2013-08-02
DWG. NO.	CE2-RF-10P2VX(RS485)-5-P1A-4A
N.O.	0

- NOTES**
- The units should use unattached power switch, stated-cross-section wires and matching-spec. breaker.
  - Use the fuse within the specified scope, it can not be replaced by iron wires or brass wires.
  - The units should install stated-cross-section earth wire and keep it grounding untaffingly.
  - Fan cable reserved at high speed file (blue); Factory defaults connecting with The black side (super high speed), if you want to get lower airflow, please connecting with high speed file (blue).

WIRE COLOR CODE		
RD RED	OR ORANGE	WH WHITE
BK BLACK	BR BROWN	YE YELLOW
BL BLUE	GN GREEN	GY GREY
PR PURPLE		

DIP Switch Description	
SW1 Description	
1# 2# 3# 4#	Unit Category
OFF OFF OFF OFF	Curt Unit
SW2 Description	
1#	ON: Cooling & Heating type
2#	ON: With Non-volatile Memory
3#	ON: Room temp. sensor T1 for Wire controller
	OFF: Without Non-volatile Memory
	OFF: Room temp. sensor T1 for Electric control panel

# 5.5 SEHP048P3A, SEHP060P3A

## CONNECTION NAMEPLATE

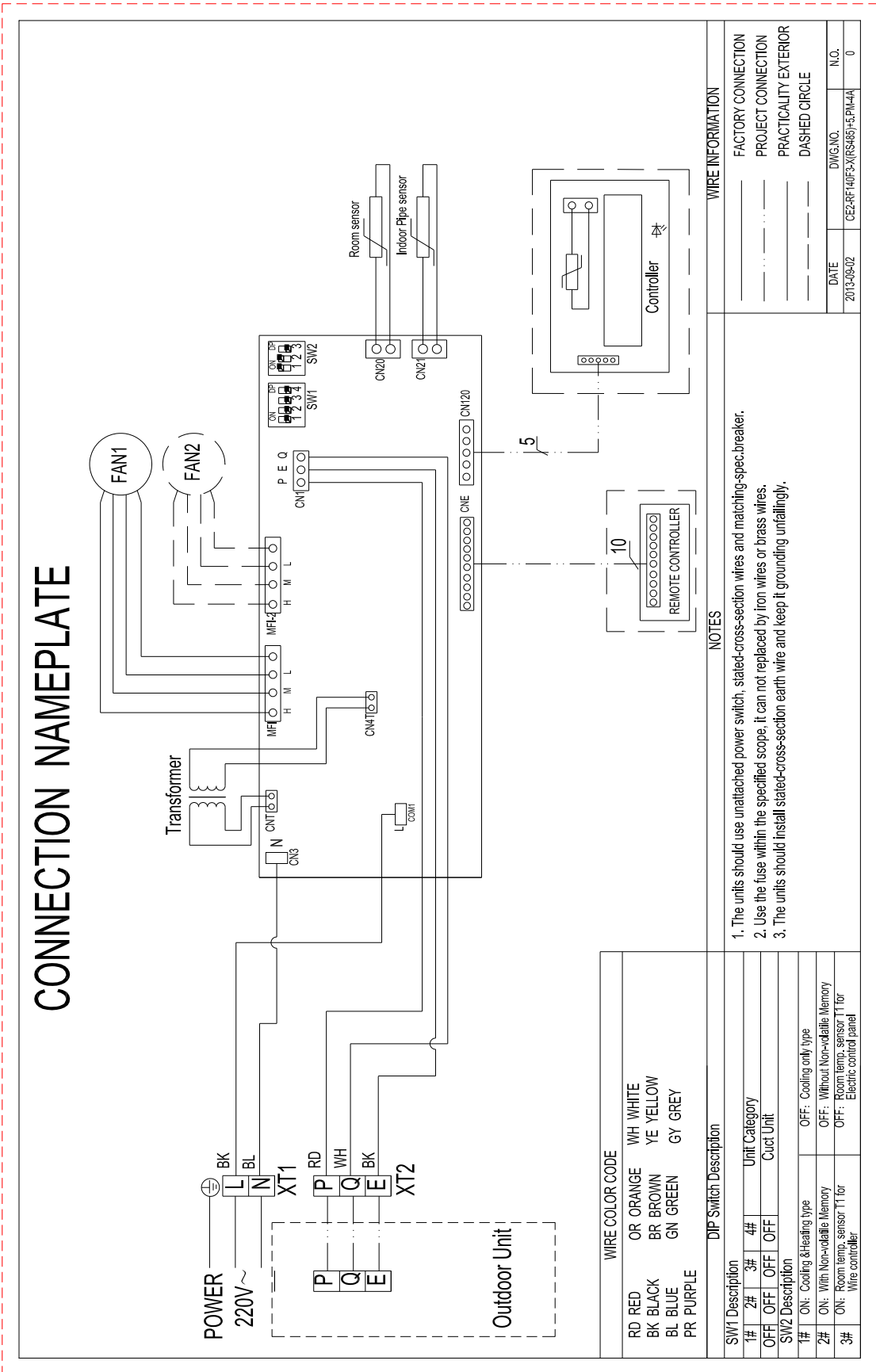

WIRE INFORMATION	
FACTORY CONNECTION	_____
PROJECT CONNECTION	_____
PRACTICALITY EXTERIOR	_____
DASHED CIRCLE	_____
DATE	2013-09-02
DWG. NO.	N.O.
	CE2-RF140F-S-X(RS465)-EPM-4A
	0

- NOTES**
1. The units should use unattached power switch, stated-cross-section wires and matching-spec. breaker.
  2. Use the fuse within the specified scope, it can not be replaced by iron wires or brass wires.
  3. The units should install stated-cross-section earth wire and keep it grounding unflinching.

WIRE COLOR CODE	
RD RED	WH WHITE
BK BLACK	BR BROWN
BL BLUE	YE YELLOW
PR PURPLE	GN GREEN
	GY GREY

DIP Switch Description	
SW1 Description	Unit Category
1# 2# 3# 4#	Cuct Unit
OFF OFF OFF OFF	
SW2 Description	
1#	OFF: Cooling only type
2#	ON: With Non-volatile Memory
3#	ON: Room temp. sensor T1 for Electric control panel
	OFF: Room temp. sensor T1 for Electric control panel

## 6.Capacity Tables

### Cooling

#### 6.1 SELP018P3A

MODEL		SELP018P3A					
COOLING		OUTDOOR TEMPERATURE DRY					
Indoor Conditions		21°C	25°C	30°C	35°C	40°C	43°C
21°C D 15°C W	Total capacity kW	5.50	5.45	5.39	5.31	4.77	4.05
	Input kW.	1.53	1.57	1.65	1.65	1.75	1.82
24°C D 17°C W	Total capacity kW	5.78	5.72	5.67	5.58	5.01	4.26
	Input kW.	1.57	1.60	1.63	1.68	1.78	1.85
27°C D 19°C W	Total capacity kW	6.07	6.01	5.95	5.86	5.26	4.47
	Input kW.	1.60	1.63	1.66	1.71	1.82	1.89
29°C D 19°C W	Total capacity kW	6.31	6.07	6.01	5.92	5.31	4.51
	Input kW.	1.63	1.56	1.59	1.64	1.74	1.81
32°C D 23°C W	Total capacity kW	6.56	6.50	6.44	6.34	5.69	4.83
	Input kW.	1.66	1.70	1.73	1.78	1.89	1.97

#### 6.2 SELP024P3A

MODEL		SELP024P3A					
COOLING		OUTDOOR TEMPERATURE DRY					
Indoor Conditions		21°C	25°C	30°C	35°C	40°C	43°C
21°C D 15°C W	Total capacity kW	6.67	6.60	6.54	6.44	5.78	4.91
	Input kW.	2.28	2.33	2.45	2.45	2.60	2.71
24°C D 17°C W	Total capacity kW	7.00	6.93	6.86	6.76	6.07	5.16
	Input kW.	2.33	2.38	2.43	2.50	2.65	2.76
27°C D 19°C W	Total capacity kW	7.35	7.28	7.21	7.10	6.37	5.41
	Input kW.	2.38	2.43	2.47	2.55	2.71	2.82
29°C D 19°C W	Total capacity kW	7.65	7.57	7.49	7.38	6.64	5.63
	Input kW.	2.43	2.47	2.52	2.60	2.76	2.87
32°C D 23°C W	Total capacity kW	7.95	7.87	7.80	7.68	6.90	5.86
	Input kW.	2.47	2.52	2.58	2.65	2.82	2.93

#### 6.3 SEMP018P3A

MODEL		SEMP018P3A					
COOLING		OUTDOOR TEMPERATURE DRY					
Indoor Conditions		21°C	25°C	30°C	35°C	40°C	43°C
21°C D 15°C W	Total capacity kW	4.98	4.93	4.88	4.81	4.32	3.67
	Input kW.	1.79	1.83	1.92	1.92	2.04	2.12
24°C D 17°C W	Total capacity kW	5.23	5.17	5.12	5.05	4.53	3.85
	Input kW.	1.83	1.86	1.90	1.96	2.08	2.16
27°C D 19°C W	Total capacity kW	5.49	5.43	5.38	5.30	4.76	4.04
	Input kW.	1.86	1.90	1.94	2.00	2.12	2.21
29°C D 19°C W	Total capacity kW	5.71	5.65	5.59	5.51	4.96	4.20
	Input kW.	1.90	1.94	1.98	2.04	2.16	2.25
32°C D 23°C W	Total capacity kW	5.94	5.88	5.82	5.73	5.15	4.37
	Input kW.	1.94	1.98	2.02	2.08	2.21	2.30

## 6.4 SEMP024P3A

MODEL		SEMP024P3A					
COOLING		OUTDOOR TEMPERATURE DRY					
Indoor Conditions		21°C	25°C	30°C	35°C	40°C	43°C
21°C D 15°C W	Total capacity kW	6.67	6.60	6.54	6.44	5.78	4.91
	Input kW.	2.37	2.42	2.55	2.55	2.70	2.81
24°C D 17°C W	Total capacity kW	7.00	6.93	6.86	6.76	6.07	5.16
	Input kW.	2.42	2.47	2.52	2.60	2.76	2.87
27°C D 19°C W	Total capacity kW	7.35	7.28	7.21	7.10	6.37	5.41
	Input kW.	2.47	2.52	2.57	2.65	2.81	2.93
29°C D 19°C W	Total capacity kW	7.65	7.57	7.49	7.38	6.64	5.63
	Input kW.	2.52	2.57	2.62	2.70	2.87	2.98
32°C D 23°C W	Total capacity kW	7.95	7.87	7.80	7.68	6.90	5.86
	Input kW.	2.57	2.62	2.68	2.76	2.93	3.04

## 6.5 SEMP036P3A

MODEL		SEMP036P3A					
COOLING		OUTDOOR TEMPERATURE DRY					
Indoor Conditions		21°C	25°C	30°C	35°C	40°C	43°C
21°C D 15°C W	Total capacity kW	9.86	9.77	9.67	9.52	8.55	7.26
	Input kW.	3.67	3.75	3.94	3.94	4.18	4.35
24°C D 17°C W	Total capacity kW	10.36	10.25	10.15	10.00	8.98	7.63
	Input kW.	3.75	3.82	3.90	4.02	4.26	4.44
27°C D 19°C W	Total capacity kW	10.87	10.76	10.66	10.50	9.42	8.01
	Input kW.	3.82	3.90	3.98	4.10	4.35	4.53
29°C D 19°C W	Total capacity kW	11.31	11.20	11.08	10.92	9.82	8.33
	Input kW.	3.90	3.98	4.06	4.18	4.44	4.62
32°C D 23°C W	Total capacity kW	11.76	11.64	11.53	11.36	10.20	8.66
	Input kW.	3.98	4.06	4.14	4.26	4.53	4.71

## 6.6 SEMP048P3A

MODEL		SEMP048P3A					
COOLING		OUTDOOR TEMPERATURE DRY					
Indoor Conditions		21°C	25°C	30°C	35°C	40°C	43°C
21°C D 15°C W	Total capacity kW	13.15	13.02	12.89	12.70	11.40	9.69
	Input kW.	4.78	4.88	5.14	5.14	5.45	5.67
24°C D 17°C W	Total capacity kW	13.81	13.67	13.54	13.34	11.97	10.17
	Input kW.	4.88	4.98	5.08	5.23	5.55	5.78
27°C D 19°C W	Total capacity kW	14.50	14.35	14.21	14.00	12.57	10.68
	Input kW.	4.98	5.08	5.18	5.34	5.67	5.90
29°C D 19°C W	Total capacity kW	15.08	14.93	14.78	14.56	13.09	11.10
	Input kW.	5.08	5.18	5.29	5.45	5.78	6.01
32°C D 23°C W	Total capacity kW	15.68	15.52	15.37	15.15	13.60	11.55
	Input kW.	5.18	5.29	5.39	5.55	5.90	6.14



**6.7 SEMP060P3A**

MODEL		SEMP060P3A					
COOLING		OUTDOOR TEMPERATURE DRY					
Indoor Conditions		21°C	25°C	30°C	35°C	40°C	43°C
21°C D 15°C W	Total capacity kW	15.03	14.88	14.73	14.51	13.03	11.07
	Input kW.	5.41	5.52	5.81	5.81	6.16	6.41
24°C D 17°C W	Total capacity kW	15.78	15.62	15.47	15.24	13.68	11.62
	Input kW.	5.52	5.63	5.75	5.92	6.28	6.54
27°C D 19°C W	Total capacity kW	16.57	16.40	16.24	16.00	14.36	12.20
	Input kW.	5.63	5.75	5.86	6.04	6.41	6.67
29°C D 19°C W	Total capacity kW	17.23	17.06	16.89	16.64	14.96	12.69
	Input kW.	5.75	5.86	5.98	6.16	6.54	6.80
32°C D 23°C W	Total capacity kW	17.92	17.74	17.57	17.31	15.54	13.20
	Input kW.	5.86	5.98	6.10	6.28	6.67	6.94

**6.8 SEHP048P3A**

MODEL		SEHP048P3A					
COOLING		OUTDOOR TEMPERATURE DRY					
Indoor Conditions		21°C	25°C	30°C	35°C	40°C	43°C
21°C D 15°C W	Total capacity kW	13.15	13.02	12.89	12.70	11.40	9.69
	Input kW.	4.93	5.03	5.29	5.29	5.61	5.84
24°C D 17°C W	Total capacity kW	13.81	13.67	13.54	13.34	11.97	10.17
	Input kW.	5.03	5.13	5.24	5.39	5.72	5.96
27°C D 19°C W	Total capacity kW	14.50	14.35	14.21	14.00	12.57	10.68
	Input kW.	5.13	5.24	5.34	5.50	5.84	6.07
29°C D 19°C W	Total capacity kW	15.08	14.93	14.78	14.56	13.09	11.10
	Input kW.	5.24	5.34	5.45	5.61	5.96	6.19
32°C D 23°C W	Total capacity kW	15.68	15.52	15.37	15.15	13.60	11.55
	Input kW.	5.34	5.45	5.55	5.72	6.07	6.32

**6.9 SEHP060P3A**

MODEL		SEHP060P3A					
COOLING		OUTDOOR TEMPERATURE DRY					
Indoor Conditions		21°C	25°C	30°C	35°C	40°C	43°C
21°C D 15°C W	Total capacity kW	15.03	14.88	14.73	14.51	13.03	11.07
	Input kW.	5.55	5.67	5.96	5.96	6.32	6.58
24°C D 17°C W	Total capacity kW	15.78	15.62	15.47	15.24	13.68	11.62
	Input kW.	5.67	5.78	5.90	6.08	6.45	6.71
27°C D 19°C W	Total capacity kW	16.57	16.40	16.24	16.00	14.36	12.20
	Input kW.	5.78	5.90	6.02	6.20	6.58	6.85
29°C D 19°C W	Total capacity kW	17.23	17.06	16.89	16.64	14.96	12.69
	Input kW.	5.90	6.02	6.14	6.32	6.71	6.98
32°C D 23°C W	Total capacity kW	17.92	17.74	17.57	17.31	15.54	13.20
	Input kW.	6.02	6.14	6.26	6.45	6.85	7.12

## Heating

### 6.10 SELP018P3A

MODEL		SELP018P3A						
Indoor Conditions		24°C DB 18°C WB	12°C DB 11°C WB	7°C DB 6°C WB	4°C DB 3°C WB	0°C DB -1°C WB	-5°C DB -6°C WB	-7°C DB -8°C WB
15°C	Capacity kW	6.69	6.56	6.46	6.15	5.94	5.47	5.18
	Input kW.	1.58	1.62	1.64	1.66	1.67	1.68	1.69
18°C	Capacity kW	6.37	6.24	6.15	5.86	5.66	5.21	4.94
	Input kW.	1.61	1.65	1.68	1.69	1.70	1.72	1.73
20°C	Capacity kW	6.07	5.95	5.86	5.58	5.39	4.96	4.70
	Input kW.	1.64	1.68	1.71	1.73	1.74	1.75	1.76
22°C	Capacity kW	5.78	5.67	5.58	5.31	5.13	4.72	4.48
	Input kW.	1.67	1.71	1.74	1.76	1.77	1.79	1.80
27°C	Capacity kW	5.50	5.39	5.31	5.06	4.89	4.50	4.26
	Input kW.	1.71	1.75	1.78	1.80	1.80	1.82	1.83

### 6.11 SELP024P3A

MODEL		SELP024P3A						
Indoor Conditions		24°C DB 18°C WB	12°C DB 11°C WB	7°C DB 6°C WB	4°C DB 3°C WB	0°C DB -1°C WB	-5°C DB -6°C WB	-7°C DB -8°C WB
15°C	Capacity kW	8.79	8.62	8.49	8.08	7.81	7.19	6.81
	Input kW.	2.35	2.41	2.45	2.48	2.49	2.51	2.53
18°C	Capacity kW	8.37	8.21	8.09	7.70	7.44	6.84	6.49
	Input kW.	2.40	2.45	2.50	2.53	2.54	2.56	2.57
20°C	Capacity kW	7.97	7.82	7.70	7.33	7.08	6.52	6.17
	Input kW.	2.45	2.50	2.55	2.57	2.59	2.62	2.63
22°C	Capacity kW	7.59	7.44	7.33	6.98	6.74	6.20	5.88
	Input kW.	2.50	2.55	2.60	2.63	2.64	2.67	2.68
27°C	Capacity kW	7.23	7.09	6.98	6.65	6.42	5.91	5.60
	Input kW.	2.55	2.60	2.65	2.68	2.69	2.72	2.73

### 6.12 SEMP018P3A

MODEL		SEMP018P3A						
Indoor Conditions		24°C DB 18°C WB	12°C DB 11°C WB	7°C DB 6°C WB	4°C DB 3°C WB	0°C DB -1°C WB	-5°C DB -6°C WB	-7°C DB -8°C WB
15°C	Capacity kW	6.62	6.49	6.39	6.09	5.88	5.41	5.13
	Input kW.	1.65	1.69	1.72	1.74	1.75	1.76	1.77
18°C	Capacity kW	6.31	6.18	6.09	5.80	5.60	5.15	4.89
	Input kW.	1.68	1.72	1.76	1.77	1.78	1.80	1.81
20°C	Capacity kW	6.01	5.89	5.80	5.52	5.33	4.91	4.65
	Input kW.	1.72	1.76	1.79	1.81	1.82	1.84	1.85
22°C	Capacity kW	5.72	5.61	5.52	5.26	5.08	4.67	4.43
	Input kW.	1.75	1.79	1.82	1.85	1.85	1.87	1.88
27°C	Capacity kW	5.45	5.34	5.26	5.01	4.84	4.45	4.22
	Input kW.	1.79	1.83	1.86	1.88	1.89	1.91	1.92

**6.13 SEMP024P3A**

MODEL		SEMP024P3A						
Indoor Conditions		24°C DB 18°C WB	12°C DB 11°C WB	7°C DB 6°C WB	4°C DB 3°C WB	0°C DB -1°C WB	-5°C DB -6°C WB	-7°C DB -8°C WB
15°C	Capacity kW	8.79	8.62	8.49	8.08	7.81	7.19	6.81
	Input kW.	2.17	2.22	2.26	2.28	2.29	2.32	2.33
18°C	Capacity kW	8.37	8.21	8.09	7.70	7.44	6.84	6.49
	Input kW.	2.21	2.26	2.30	2.33	2.34	2.36	2.37
20°C	Capacity kW	7.97	7.82	7.70	7.33	7.08	6.52	6.17
	Input kW.	2.25	2.31	2.35	2.37	2.38	2.41	2.42
22°C	Capacity kW	7.59	7.44	7.33	6.98	6.74	6.20	5.88
	Input kW.	2.30	2.35	2.40	2.42	2.43	2.46	2.47
27°C	Capacity kW	7.23	7.09	6.98	6.65	6.42	5.91	5.60
	Input kW.	2.35	2.40	2.45	2.47	2.48	2.51	2.52

**6.14 SEMP036P3A**

MODEL		SEMP036P3A						
Indoor Conditions		24°C DB 18°C WB	12°C DB 11°C WB	7°C DB 6°C WB	4°C DB 3°C WB	0°C DB -1°C WB	-5°C DB -6°C WB	-7°C DB -8°C WB
15°C	Capacity kW	13.02	12.76	12.57	11.96	11.56	10.64	10.08
	Input kW.	3.59	3.68	3.75	3.78	3.80	3.84	3.86
18°C	Capacity kW	12.40	12.15	11.97	11.39	11.01	10.13	9.60
	Input kW.	3.66	3.75	3.82	3.86	3.88	3.92	3.94
20°C	Capacity kW	11.81	11.57	11.40	10.85	10.48	9.65	9.14
	Input kW.	3.74	3.83	3.90	3.94	3.96	4.00	4.02
22°C	Capacity kW	11.24	11.02	10.86	10.33	9.98	9.18	8.71
	Input kW.	3.82	3.91	3.98	4.02	4.04	4.08	4.10
27°C	Capacity kW	10.71	10.50	10.34	9.84	9.51	8.75	8.29
	Input kW.	3.89	3.98	4.06	4.10	4.11	4.16	4.18

**6.15 SEMP048P3A**

MODEL		SEMP048P3A						
Indoor Conditions		24°C DB 18°C WB	12°C DB 11°C WB	7°C DB 6°C WB	4°C DB 3°C WB	0°C DB -1°C WB	-5°C DB -6°C WB	-7°C DB -8°C WB
15°C	Capacity kW	17.36	17.01	16.76	15.95	15.41	14.18	13.44
	Input kW.	5.01	5.14	5.23	5.28	5.31	5.36	5.39
18°C	Capacity kW	16.53	16.20	15.96	15.19	14.68	13.51	12.81
	Input kW.	5.11	5.24	5.33	5.39	5.41	5.47	5.49
20°C	Capacity kW	15.74	15.43	15.20	14.47	13.97	12.86	12.19
	Input kW.	5.22	5.34	5.44	5.49	5.52	5.58	5.61
22°C	Capacity kW	14.99	14.70	14.48	13.78	13.31	12.25	11.61
	Input kW.	5.32	5.45	5.55	5.61	5.63	5.69	5.71
27°C	Capacity kW	14.28	13.99	13.78	13.12	12.68	11.67	11.06
	Input kW.	5.43	5.56	5.66	5.71	5.74	5.80	5.83

**6.16 SEMP060P3A**

MODEL		SEMP060P3A						
Indoor Conditions		24°C DB 18°C WB	12°C DB 11°C WB	7°C DB 6°C WB	4°C DB 3°C WB	0°C DB -1°C WB	-5°C DB -6°C WB	-7°C DB -8°C WB
15°C	Capacity kW	18.27	17.91	17.64	16.79	16.22	14.93	14.15
	Input kW.	5.66	5.8	5.9	5.96	5.99	6.05	6.1
18°C	Capacity kW	17.4	17.05	16.8	15.99	15.45	14.22	13.48
	Input kW.	5.77	5.91	6.02	6.08	6.11	6.17	6.2
20°C	Capacity kW	16.57	16.24	16.0	15.23	14.71	13.54	12.83
	Input kW.	5.89	6.03	6.14	6.2	6.23	6.3	6.33
22°C	Capacity kW	15.78	15.47	15.24	14.5	14.01	12.89	12.22
	Input kW.	6.01	6.15	6.26	6.33	6.36	6.42	6.45
27°C	Capacity kW	15.03	14.73	14.51	13.81	13.35	12.28	11.64
	Input kW.	6.13	6.27	6.39	6.45	6.48	6.55	6.58

**6.17 SEHP048P3A**

MODEL		SEHP048P3A						
Indoor Conditions		24°C DB 18°C WB	12°C DB 11°C WB	7°C DB 6°C WB	4°C DB 3°C WB	0°C DB -1°C WB	-5°C DB -6°C WB	-7°C DB -8°C WB
15°C	Capacity kW	17.58	17.24	16.98	16.16	15.61	14.37	13.62
	Input kW.	5.16	5.29	5.38	5.44	5.46	5.52	5.55
18°C	Capacity kW	16.75	16.41	16.17	15.39	14.87	13.69	12.97
	Input kW.	5.26	5.39	5.49	5.55	5.57	5.63	5.65
20°C	Capacity kW	15.95	15.63	15.40	14.66	14.16	13.03	12.35
	Input kW.	5.37	5.50	5.60	5.65	5.68	5.75	5.77
22°C	Capacity kW	15.19	14.89	14.67	13.96	13.48	12.41	11.76
	Input kW.	5.48	5.61	5.71	5.77	5.80	5.86	5.88
27°C	Capacity kW	14.47	14.18	13.97	13.29	12.85	11.82	11.20
	Input kW.	5.59	5.72	5.83	5.88	5.91	5.97	6.00

**6.18 SEHP060P3A**

MODEL		SEHP060P3A						
Indoor Conditions		24°C DB 18°C WB	12°C DB 11°C WB	7°C DB 6°C WB	4°C DB 3°C WB	0°C DB -1°C WB	-5°C DB -6°C WB	-7°C DB -8°C WB
15°C	Capacity kW	18.27	17.91	17.64	16.79	16.22	14.93	14.15
	Input kW.	5.81	5.95	6.05	6.12	6.15	6.21	6.24
18°C	Capacity kW	17.40	17.05	16.80	15.99	15.45	14.22	13.48
	Input kW.	5.92	6.06	6.18	6.24	6.27	6.33	6.36
20°C	Capacity kW	16.57	16.24	16.00	15.23	14.71	13.54	12.83
	Input kW.	6.04	6.19	6.30	6.36	6.39	6.46	6.49
22°C	Capacity kW	15.78	15.47	15.24	14.50	14.01	12.89	12.22
	Input kW.	6.17	6.31	6.42	6.49	6.53	6.59	6.62
27°C	Capacity kW	15.03	14.73	14.51	13.81	13.35	12.28	11.64
	Input kW.	6.29	6.43	6.56	6.62	6.65	6.72	6.75

## 7.Static Pressure

### 7.1 SELP018P3A

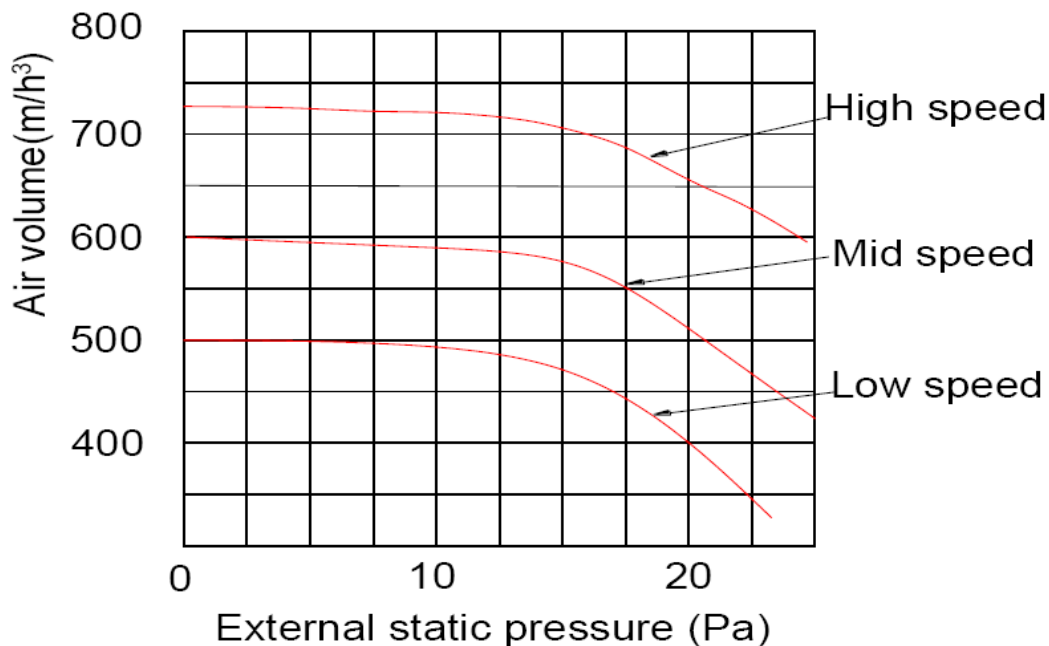

### 7.2 SELP024P3A

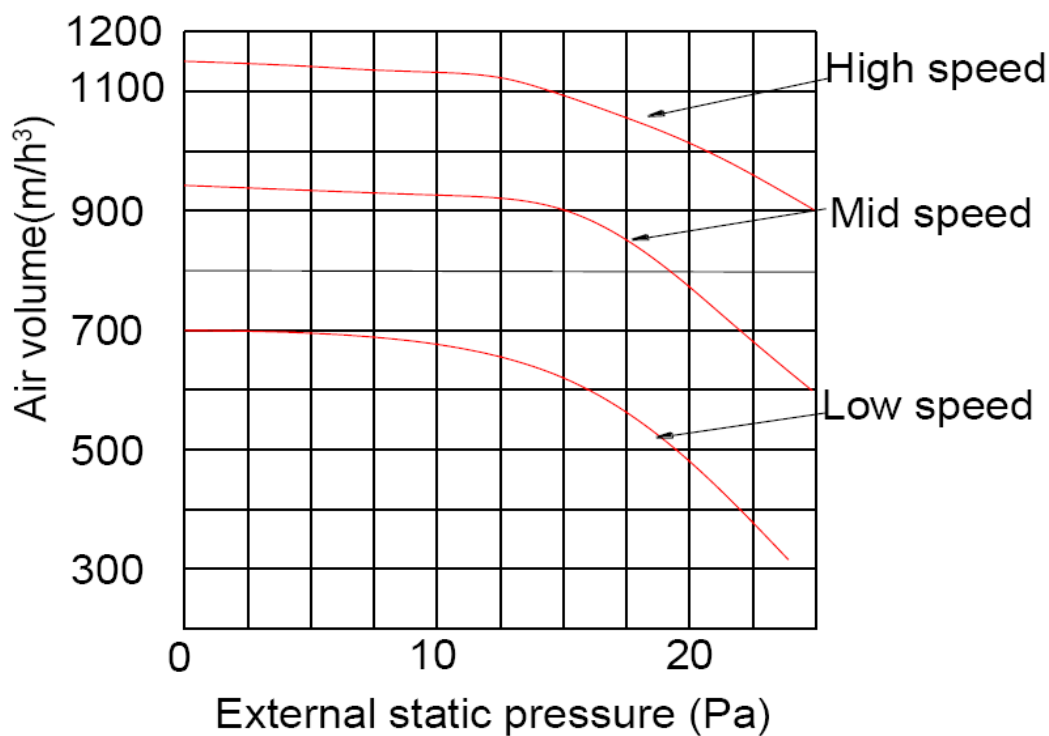

### 7.3 SEMP018P3A

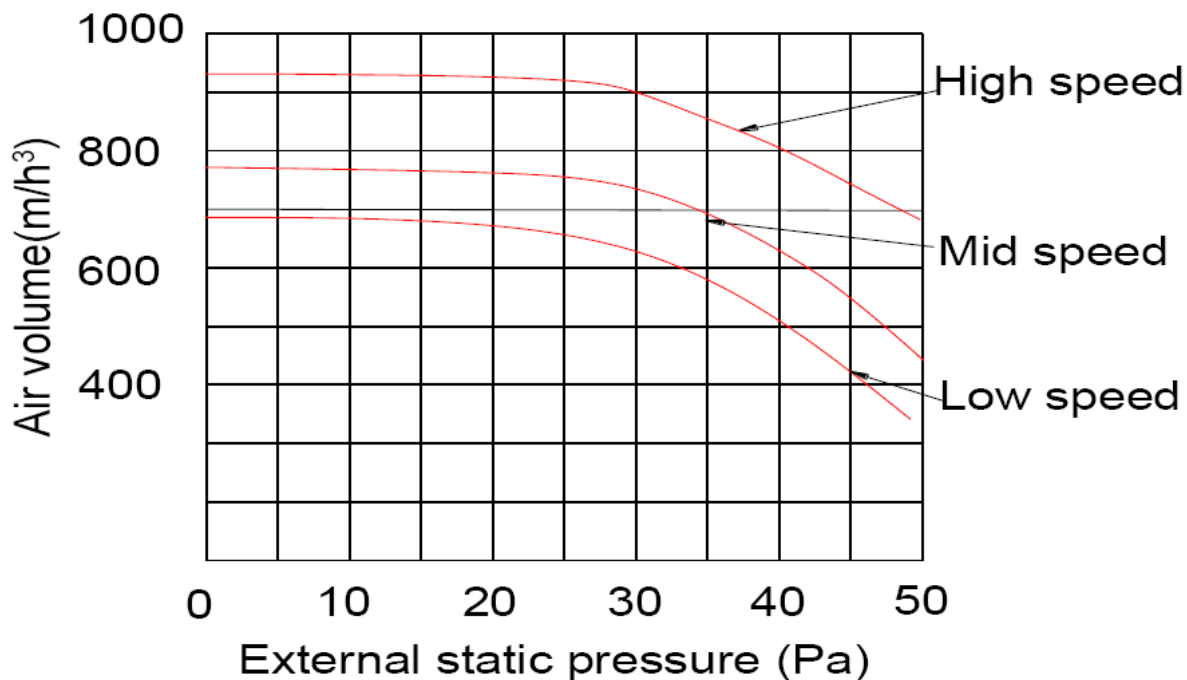

### 7.4 SEMP024P3A

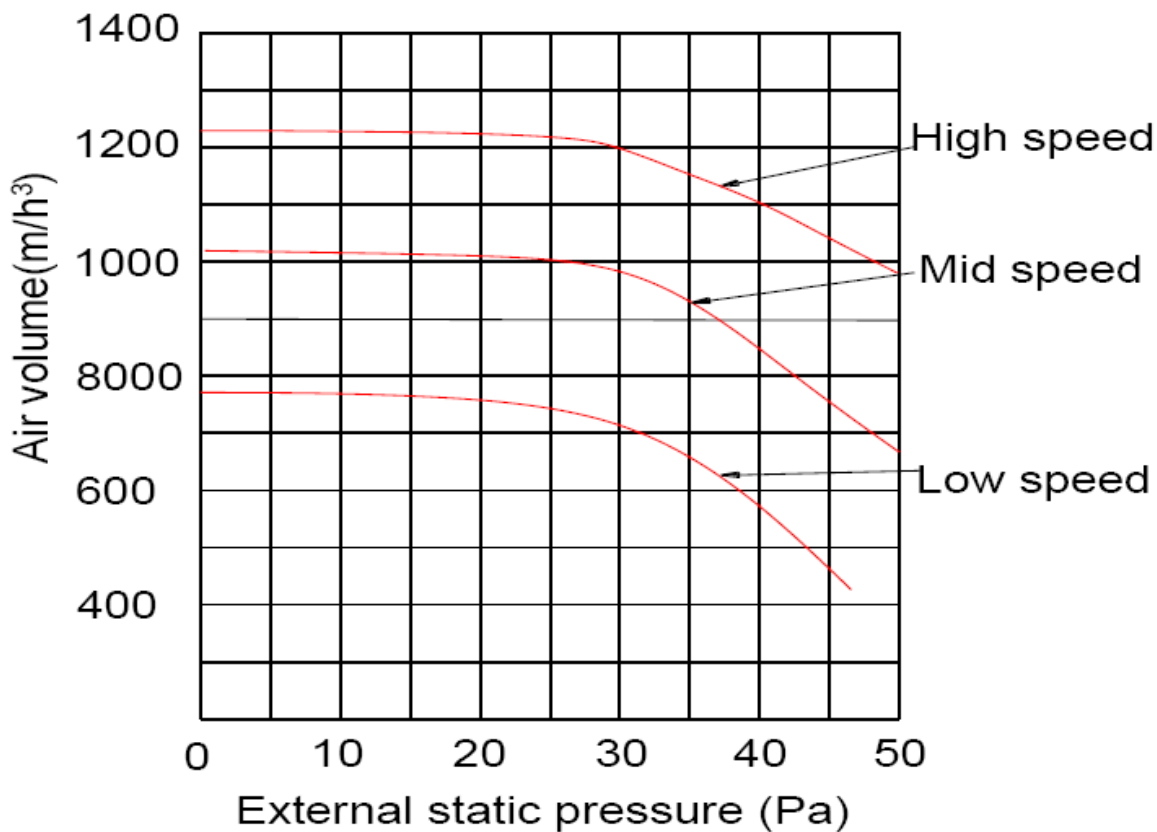

### 7.5 SEMP036P3A

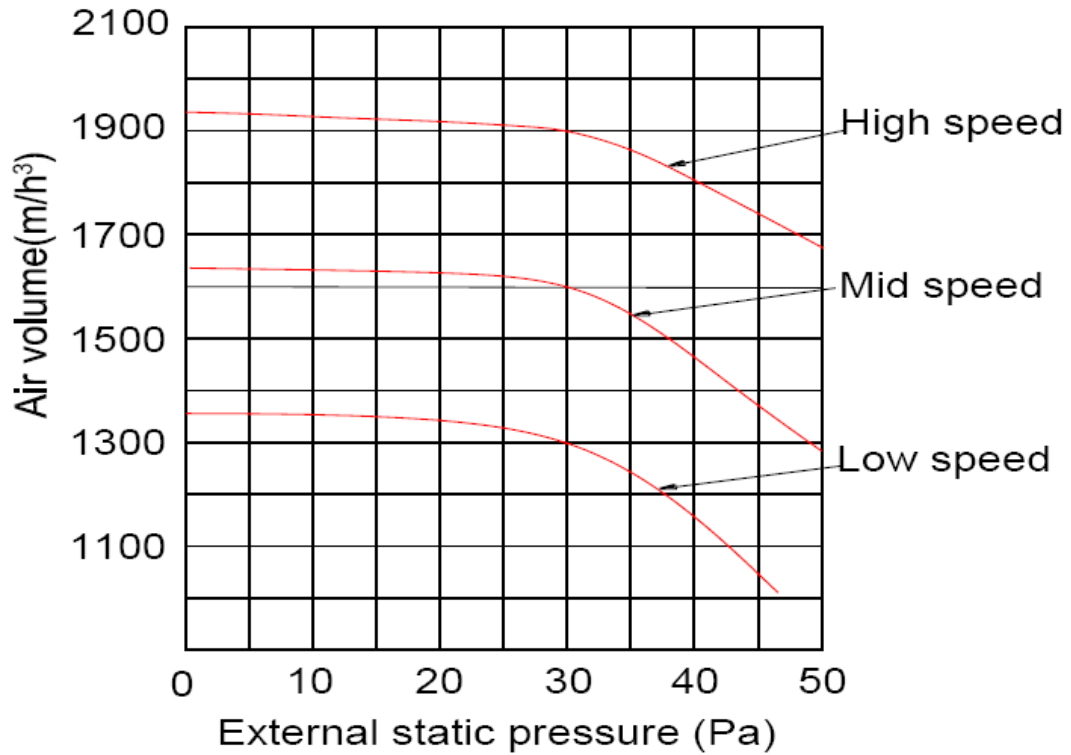

### 7.6 SEMP048P3A, SEMP060P3A

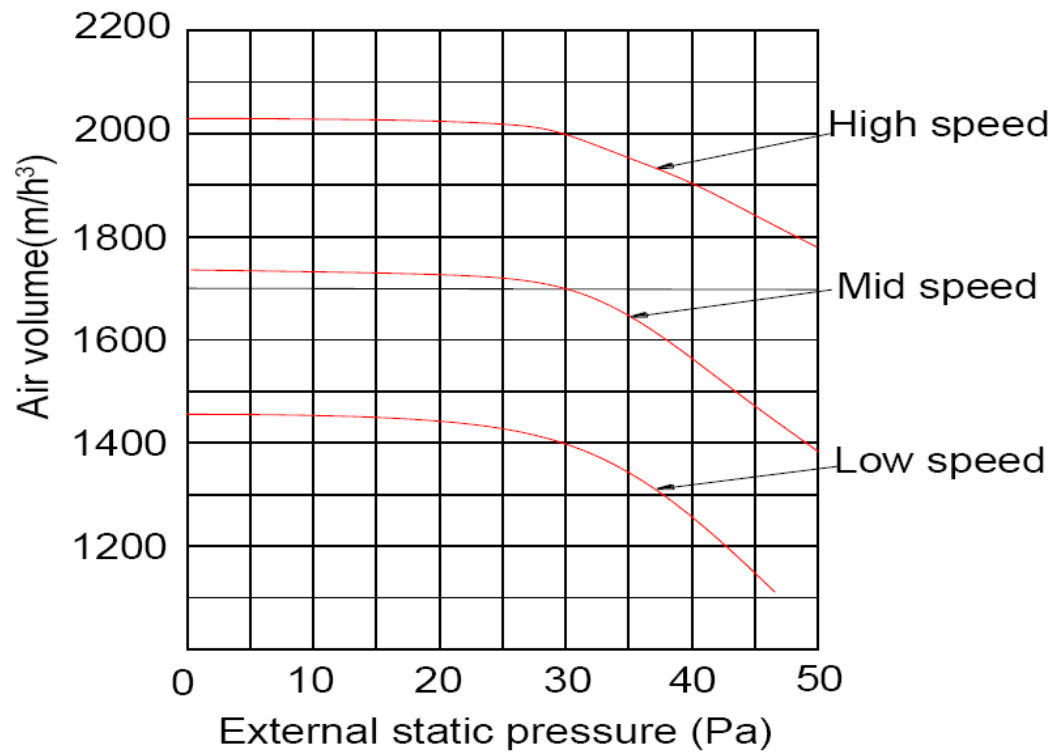

## 7.8 SEHP048P3A, SEHP060P3A

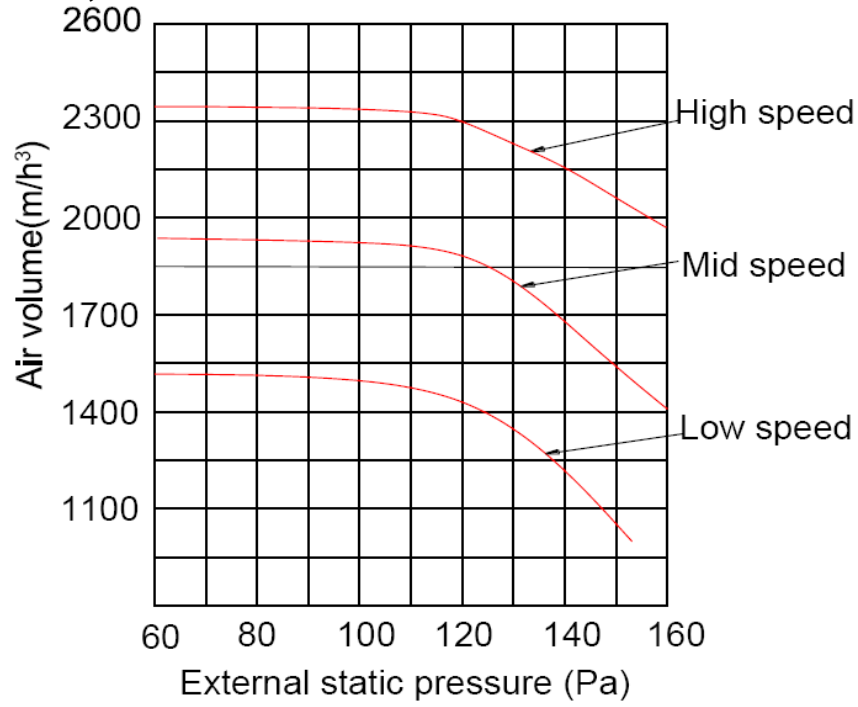



## 8. Electric Characteristics





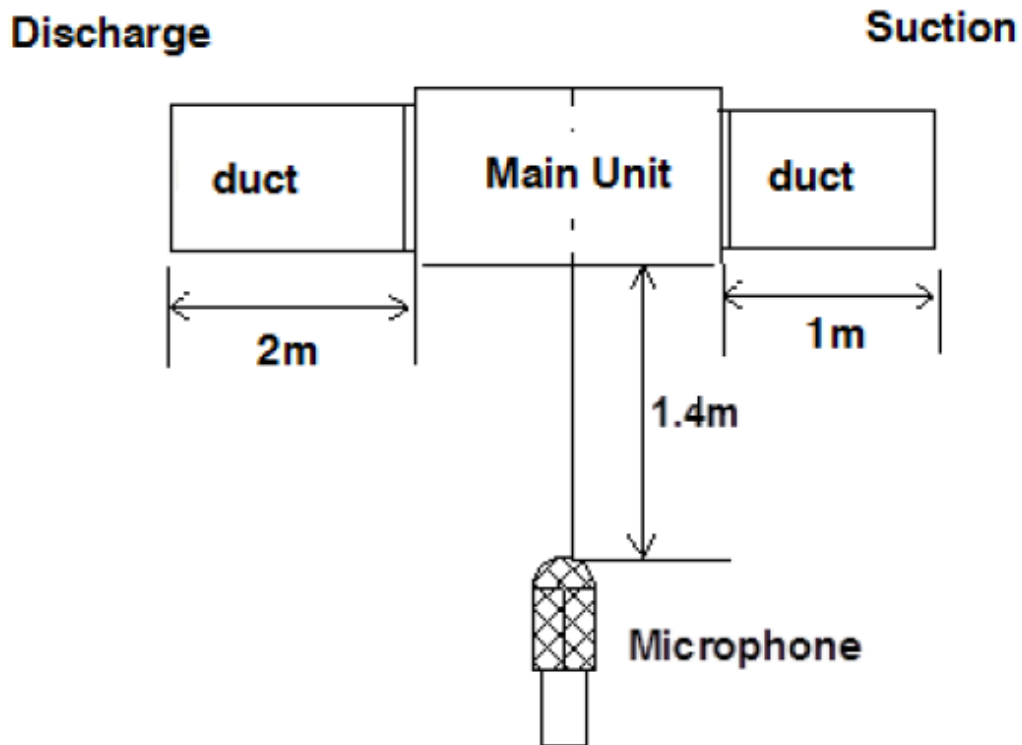

Model	Indoor Units				Indoor Fan Motor
	Hz	Voltage	Min.	Max.	kW
SELP018P3A	50	220-240V	198V	254V	0.07
SELP024P3A	50	220-240V	198V	254V	0.15
SEMP018P3A	50	220-240V	198V	254V	0.25
SEMP024P3A	50	220-240V	198V	254V	0.25
SEMP036P3A	50	220-240V	198V	254V	0.30
SEMP048P3A	50	220-240V	198V	254V	0.34
SEMP060P3A	50	220-240V	198V	254V	0.34
SEHP048P3A	50	220-240V	198V	254V	0.50
SEHP060P3A	50	220-240V	198V	254V	0.50

## 9.Sound Levels



Model		SELP018P3A	SELP024P3A	SEMP018P3A	SEMP024P3A	SEMP036P3A
Noise Level	dB(A)	37 ~ 46	38 ~ 48	40 ~ 48	40 ~ 48	40 ~ 50
Model		SEMP048P3A	SEMP060P3A	CTH-48HR1	CTH-60HR1	/
Noise Level	dB(A)	40 ~ 50	40 ~ 50	44 ~ 52	44 ~ 52	/

## 10.Accessories

	Name	Shape	Quantity
Tubing & Fittings	Soundproof/insulation sheath		2
	Binding tape		1
	Seal sponge		1
Drainpipe Fittings	Seal ring		1
Controller	Wire controller		1
	Remote controller (optional)		1
others	Operation & installation instruction manual		1

## 11.The Specification of Wiring

Model		18kBtu/h	24kBtu/h	36kBtu/h
Indoor power supply	V/Ph/Hz	220~240/1/50		
Outdoor power supply	V/Ph/Hz	220~240/1/50		
Connection wiring	Outdoor Power Supply	Power	From indoor unit	Power supply individually for indoor and outdoor
	Power wiring	mm <sup>2</sup>	3×2.5	3×2.5/3×1.0      3×4.0/3×1.0
	Signal wiring	mm <sup>2</sup>	5×1.5	RS485 twisted shielded wire pair 2×0.5

Model		36kBtu/h	48kBtu/h	60kBtu/h	
Indoor power supply	V/Ph/Hz	220~240/1/50			
Outdoor power supply	V/Ph/Hz	380~415/3/50			
Connection wiring	Outdoor Power Supply		Power supply individually for indoor and outdoor		
	Power wiring	mm <sup>2</sup>	5×1.5/3×1.0	5×1.5/3×1.0	5×2.5/3×1.0
	Signal wiring	mm <sup>2</sup>	RS485 twisted shielded wire pair 2×0.5		

## 12. Field Wiring

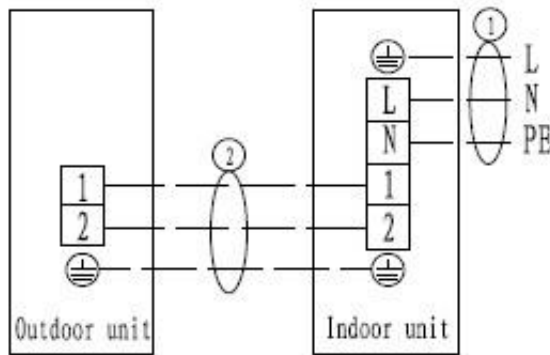

**Fig 1**  
Applicable for 9K~18K cooling only type

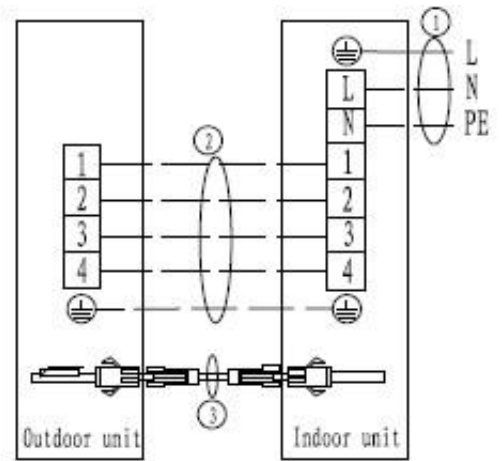

**Fig 2**  
Applicable for 9K~18K heatpump type

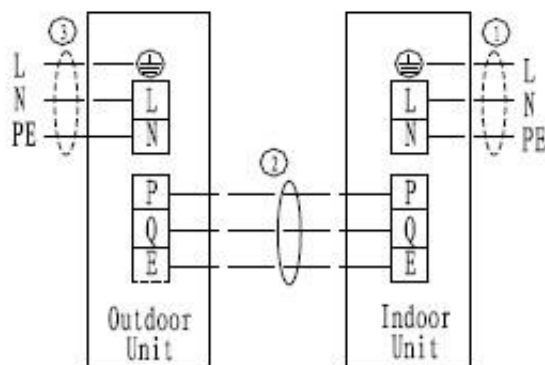

**Fig 3**  
Applicable for 24K, 36K single-phase cooling and heatpump type

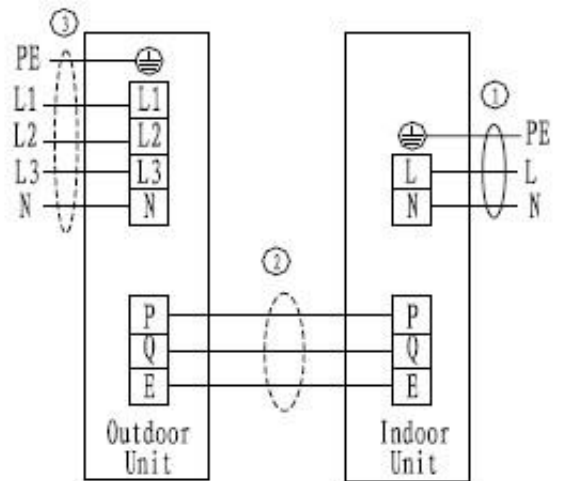

**Fig 4**  
Applicable for 24K, 36K, 48K, 60K three-phase cooling and heatpump type

## 13.Exploded View

### 13.1 SELP018P3A, SELP024P3A

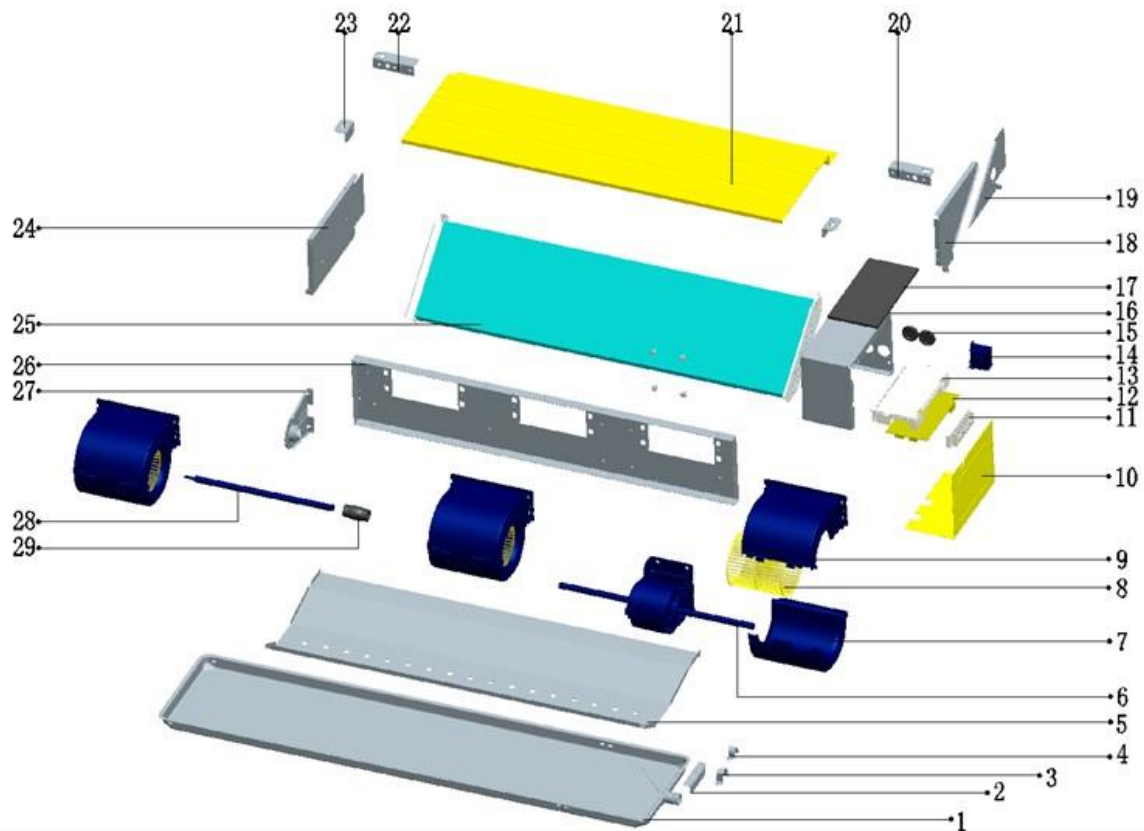

No.	Part Name	Quantity	No.	Part Name	Quantity
1	Water pan welding assy	1	17	Sponges	1
2	Fixing board for inlet and outlet pipe	1	18	Left rear clapboard	1
3	Pipe clamp1	1	19	Left front clapboard	1
4	Pipe clamp2	1	20	Front hanger A	1
5	Evaporator chassis	1	21	Upper cover	1
6	Motor for indoor unit	1	22	Front hanger B	1
7	Lower scroll case	3	23	Hanger	2
8	Centrifugal wind wheel	3	24	Right clapboard	1
9	Upper scroll case	3	25	Evaporator assy	1
10	E-parts box cover	1	26	Fan fixing board assy	1
11	Terminal	1	27	Motor support assy	1
12	Electronic control board for indoor unit	1	27.1	No.13 Bearing holder	1
13	Plastic base for PCB	1	27.2	Motor support	1
14	Transformer	1	28	Axis2	1
15	Small rubber ring that through the coils	2	29	Coupling	1
16	Electric control mounting plate welded assy	1			

## 13.2 SEMP018P3A, SEMP024P3A

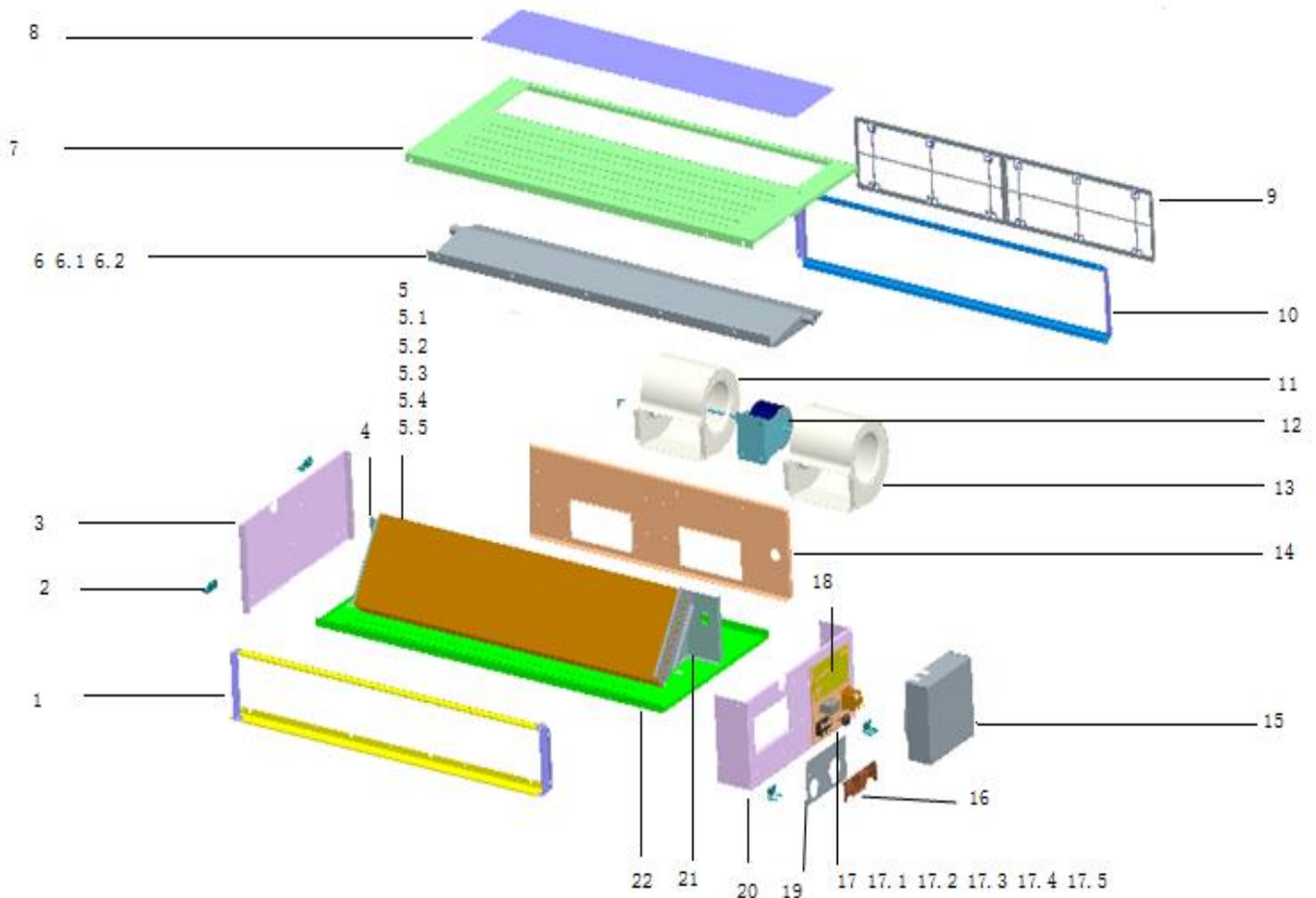

No.	Part Name	Quantity	No.	Part Name	Quantity
1	outlet assy	1	11	scroll case(left)	1
2	hanger	4	12	Fan motor	1
3	left clapboard	1	13	scroll case(right)	1
4	Left end plate of Evaporator	1	14	Fan fixing board assy	1
5	Evaporator assy	1	15	E-parts box cover assy	1
5.1	Transition tube	6	16	Small cover plate	1
5.2	Shunt assy	1	17	E-parts	1
5.3	air header assy	1	17.1	Main control board	1
5.4	Evaporator	1	17.2	Temperature sensor	1
5.5	Probe copper tube	1	17.3	PTC transformer	1
6	Welding assy for water collector	1	17.4	Terminal	1
6.1	leading	2	17.5	NO.7Line pressing buckle	2
6.2	effluent joint rubber cap	2	18	E-parts box base	1
7	Lower plate	1	19	big cover plate	1
8	Return air damper	1	20	Right clapboard	1
9	filter screen	2	21	Right end plate of Evaporator	1
10	Return air assy	1	22	Upper plate	1

### 13.3 SEMP036P3A, SEMP048P3A, SEMP060P3A

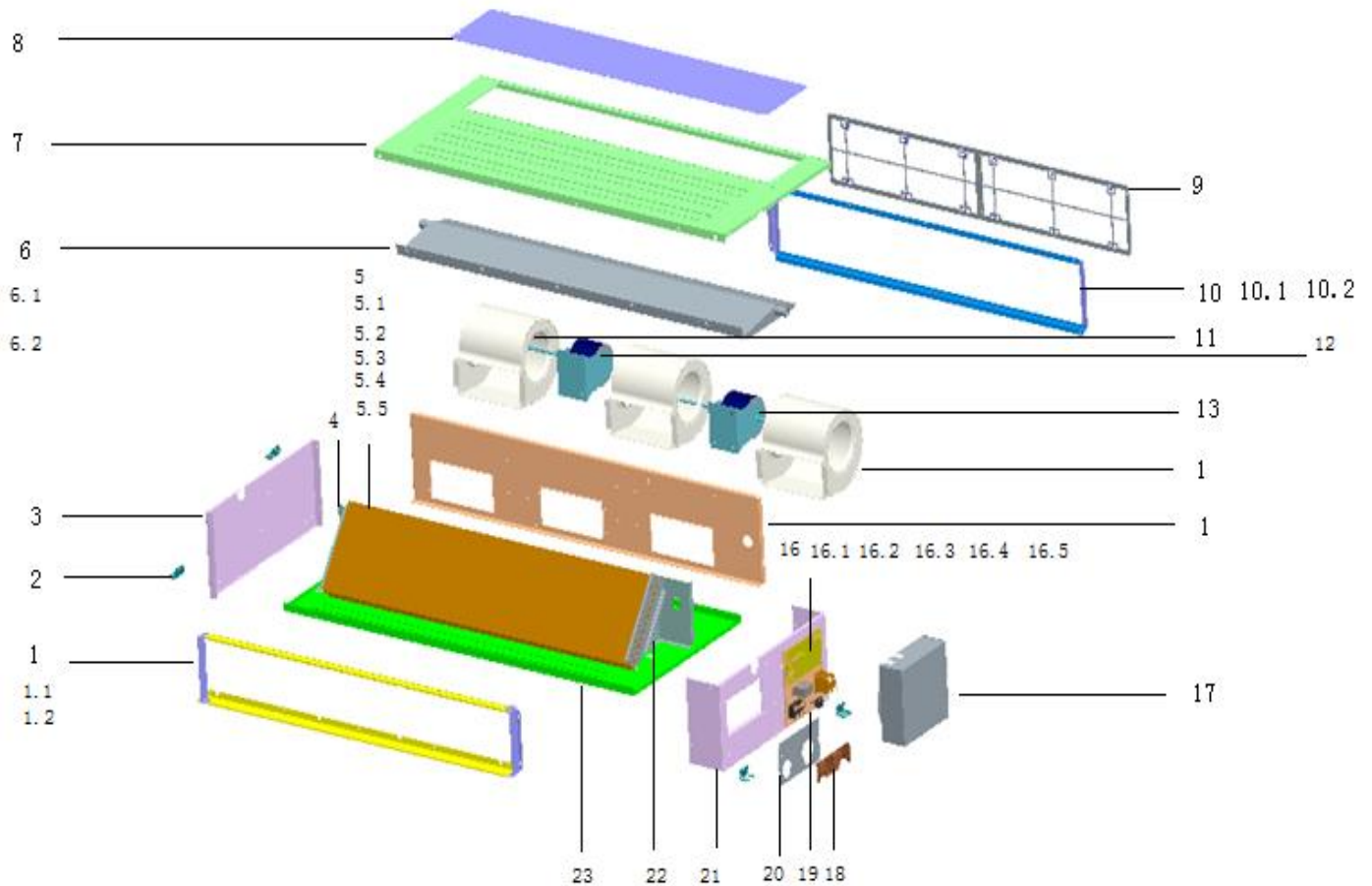

No.	Part Name	Quantity	No.	Part Name	Quantity
1	outlet assy	1	10.2	return air left-right rail	2
1.1	outlet left-right rail	2	11	scroll case(left)	1
1.2	outlet upper-lower rail	2	12	Fan motor	1
2	hanger	4	13	Fan motor	1
3	left clapboard	1	14	scroll case(right)	2
4	Left end plate of Evaporator	1	15	Fan fixing board assy	1
5	Evaporator assy	1	16	E-parts	1
5.1	Transition tube	5	16.1	Main control board	1
5.2	Shunt assy	1	16.2	Temperature sensor	1
5.3	air header assy	1	16.3	PTC transformer	1
5.4	Evaporator	1	16.4	Terminal	1
5.5	Probe copper tube	1	16.5	NO.7Line pressing buckle	2
6	Welding assy for water collector	1	17	E-parts box cover assy	1
6.1	leading	2	18	Small cover plate	1
6.2	effluent joint rubber cap	2	19	E-parts box base	1
7	Lower plate	1	20	big cover plate	1
8	Return air damper	1	21	Right clapboard	1
9	filter screen	2	22	Right end plate of Evaporator	1
10	Return air assy	1	23	Upper plate	1
10.1	return air upper-lower rail	2			



## 13.4 SEHP048P3A, SEHP060P3A

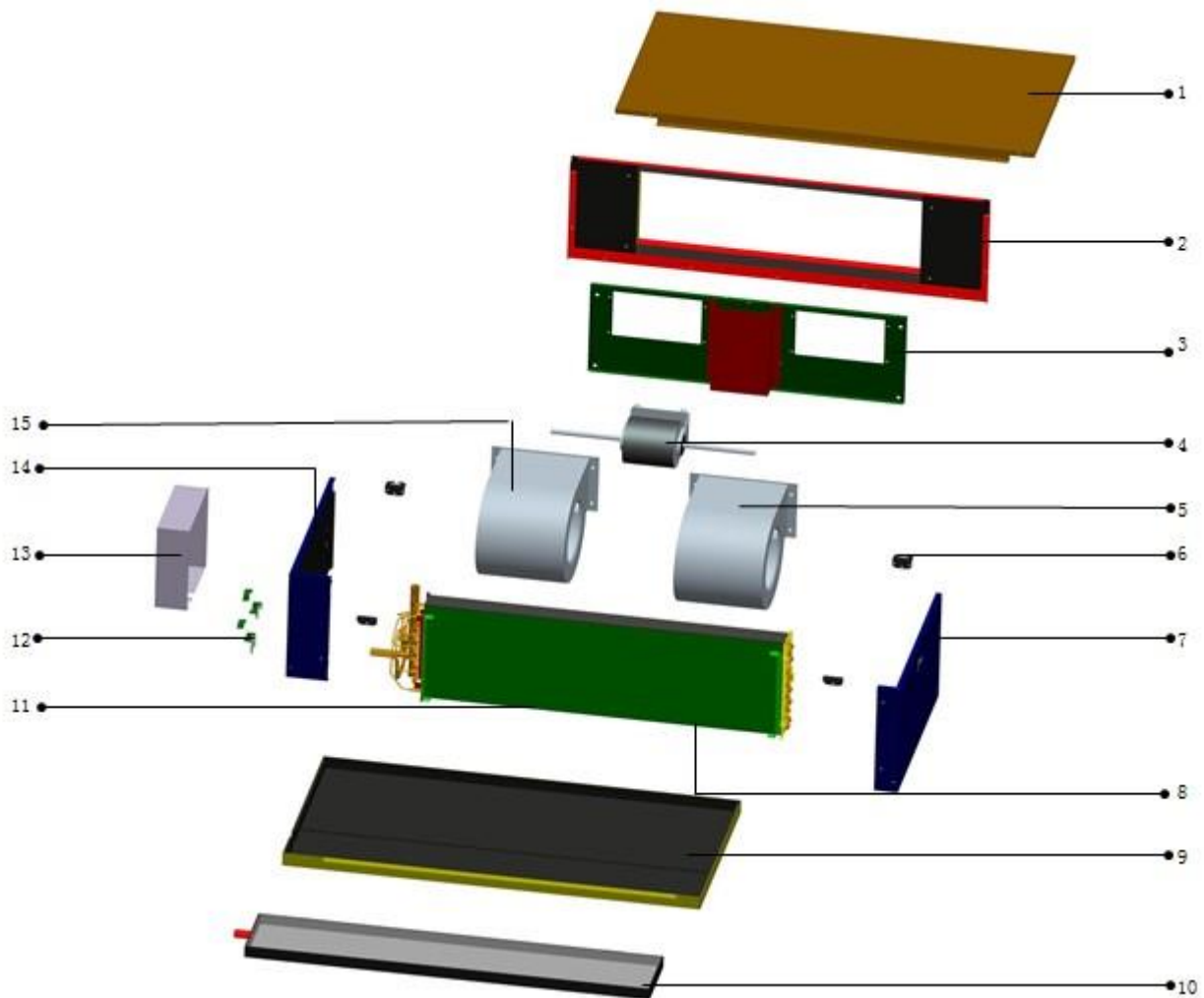

No.	Part Name	Quantity	No.	Part Name	Quantity
1	Head cover assy	1	12.2	φ35 upper Pipe clamp	1
2	Front panel	1	12.3	φ20 lower Pipe clamp	1
3	Fixing board assy for fan	1	12.4	φ35 lower Pipe clamp	1
4	Twin screw Motor for indoor unit	1	13	Electric control components	1
5	Left wind wheel scroll case	1	13.1	Electric control board assy for indoor unit	1
6	Hanger	4	13.2	Temp sensor	1
7	left clapboard assy	1	13.2.1	Room temp sensor	1
8	Fixing board for Air return	2	13.2.2	Indoor Pipe temp sensor	1
9	Base plate assy	1	13.3	transformer	1
10	Water pan assy	1	13.4	Terminal	1
11	Evaporator assy	1	14	Right clapboard assy	1
12	Pipe clamp	1	15	Right wind wheel scroll case	1
12.1	φ20 upper Pipe clamp	1			

## 14.Troubleshooting

### Fault code table

4LED Faults	Digital display	Failure description
Timer light flashing	E2	Ambient temperature sensor (T1) failure
Running light flashing	E3	Evaporator pipe temperature sensor (T2) failure
Defrost light flashing	E5	Condenser pipe temperature sensor (T3) failure
Warning light flashing	F5	Water full filled protection
Running light, defrost light flashing	E1	Indoor unit and wire controller communication failure
Running light, timer light flashing	P6	Indoor unit EEPROM failure
Defrost light, timer light flashing	F0	Indoor fan stall protection
Defrost light, warning light flashing	F2	Outdoor protection
	F7	Outdoor over-current protection
Timer light, warning light flashing	E0	Indoor unit and outdoor unit communication failure
Running light, defrost light, timer light flashing	F3	High pressure protection
Defrost light , timer light, warning light flashing	F4	Low pressure protection
Running light, timer light, warning light flashing	F8	Outdoor unit exhaust temperature over-high protection
Running light, defrost light, timer light, warning light flashing	F9	Three-phase electricity phase sequence failure
Note: the flashing frequency for all above indication lights is 1HZ.		

# Floor & Ceiling

1.Features .....	79
2.Specifications.....	81
3.Dimensions .....	82
4.Service Space .....	85
5.Wiring Diagrams .....	86
6.Capacity Table.....	89
7.Electric Characteristics .....	93
8.Sound Levels .....	94
9.Exploded View .....	95
10.Accessories .....	99
11.The Specification of Power .....	100
12.Field Wiring .....	101
13.Troubleshooting.....	102

## 1.Features

1. Flexible installation, ceiling suspended and floor standing.



2. Adopting centrifugal fans, higher ESP and longer air flow distance.



3. Two way auto-swing function, built-in two louver motor, vertical and horizontal air-flow adjustment.



4. Washable air filter



5. LED display for optional.



6. New upper and lower buckle type wheel case, the upper plastic wheel case can be removed Alone, which is convenient adjust the wheel motor.



7. Water pump optional, pumping head is up to 1200mm.

8. Adopting waterproof plastic film on water collector, avoiding water leakage.



9. Self-diagnostic function and multi protection; Auto-restart function.



10. Standard for wireless controller; option for wired controller



Standard



Optional

## 2.Specifications

Model			SEFC018C3A	SECF024C3A	SEFC036C3A
Indoor power supply		V/Ph/Hz	220~240V/1Ph/50Hz	220~240V/1Ph/50Hz	220~240V/1Ph/50Hz
Cooling	Capacity	Btu/h	18000	24000	36000
		KW	5.3	7.1	10.5
	Input	W	130	150	300
	Rated current	A	0.3	0.7	1.4
	EER	W/W	2.61	2.78	2.56
Heating	Capacity	Btu/h	19800	26000	39000
		KW	5.9	7.7	11.5
	Input	W	130	150	300
	Rated current	A	0.3	0.68	1.4
	COP	W/W	3.24	3.42	2.95
Indoor fan motor	Model		YSK110-65LD-4P3H 85	YSK110-75LD-4P2	YSK110-180LD-4P2
	Input	W	130	150	300
	Capacitor	μF	3	5	5
	Speed(Hi/Me/Lo)	r/min	1350/1270/1180	980/880/780	1310/1210/1110
Indoor coil	Number of rows		3	2	3
	Fin spacing	mm	2	1.4	1.7
	Fin type		Hydrophilic	Hydrophilic	Hydrophilic
	Number of circuits		3	5	5
Indoor air flow(High speed)		m <sup>3</sup> /h	790	1300	1700
Indoor noise level		dB(A)	44~52	39~48	44~52
Indoor unit	Dimension (W*H*D)	mm	880×635×203	1245×680×247	1245×680×247
	Packing(W*H*D)	mm	970×725×301	1325×770×330	1325×770×330
	Net/Gross weight	kg	30/35	35/41	37/43
Max pressure		MPa	4.0	4.0	4.0
Refrigerant type			R410A	R410A	R410A
Refrigerant piping	Liquid side/ Gas side	mm	Φ6.35/Φ12.7	Φ9.52/Φ15.88	Φ9.52/Φ19.05
Drainage pipe		mm	25	25	25
Standard controller			Standard for remote controller(wired controller for option)		
Operation temp		°C	16~32	16~32	16~32
Ambient temp		°C	-7~43	-7~43	-7~43
Application area		m <sup>2</sup>	20-35	28-50	40-70
Stuffing Quantity(20'/40'/40'HQ)		set	132/270/306	75/165/189	75/165/189

Model			SEFC048C3A	SEFC060C3A
Indoor power supply		V/Ph/Hz	220~240V/1Ph/50Hz	220~240V/1Ph/50Hz
Cooling	Capacity	Btu/h	48000	60000
		KW	14	16
	Input	W	260	260
	Rated current	A	1.15	1.15
EER	W/W	2.66	2.68	
Heating	Capacity	Btu/h	52000	60000
		KW	15.2	16.0
	Input	W	260	260
	Rated current	A	1.15	1.15
COP	W/W	2.84	2.64	
Indoor fan motor	Model		YSK110-59LD-4P17 +YSK110-59LD-4P17	YSK110-59LD-4P17 +YSK110-59LD-4P17
	Input	W	260	260
	Capacitor	μF	3+3	3+3
	Speed(Hi/Me/Lo)	r/min	1310/1139/1016	1310/1139/1016
Indoor coil	Number of rows		2	2
	Fin spacing	mm	1.5	1.5
	Fin type		Hydrophilic	Hydrophilic
	Number of circuits		5	5
Indoor air flow(High speed)		m <sup>3</sup> /h	2300	2300
Indoor noise level		dB(A)	57	57
Indoor unit	Dimension(W*H*D)		mm	1670×680×247
	Packing(W*H*D)		mm	1750×770×330
	Net/Gross weight		kg	47/54
Max pressure		MPa	4.5	4.5
Refrigerant type			R410A	R410A
Refrigerant piping	Liquid side/Gas side	mm	Φ9.52/Φ19.05	Φ9.52/Φ19.05
Drainage pipe		mm	25	25
Standard controller			Standard for remote controller(wired controller for option)	
Operation temp		°C	16~32	16~32
Ambient temp		°C	-7~43	-7~43
Application area		m <sup>2</sup>	55~95	60~105
Stuffing Quantity(20'/40'/40'HQ)		set	60/120/123	60/120/123

**Notes:**

1. Nominal cooling capacities are based on the following conditions:

Indoor temp: 27°CDB, 19°CWB; Outdoor temp: 35°CDB; Equivalent ref. Piping: 5m(horizontal)

2. Nominal heating capacities are based on the following conditions:

Indoor temp: 20°CDB; Outdoor temp: 7°CDB, 6°CWB; Equivalent ref. Piping: 5m(horizontal)

3. Actual noise level may differ, depending on the room structure, etc, since these noise values are from an anechoic room.

### 3. Dimensions

#### 3.1 SEFC018C3A

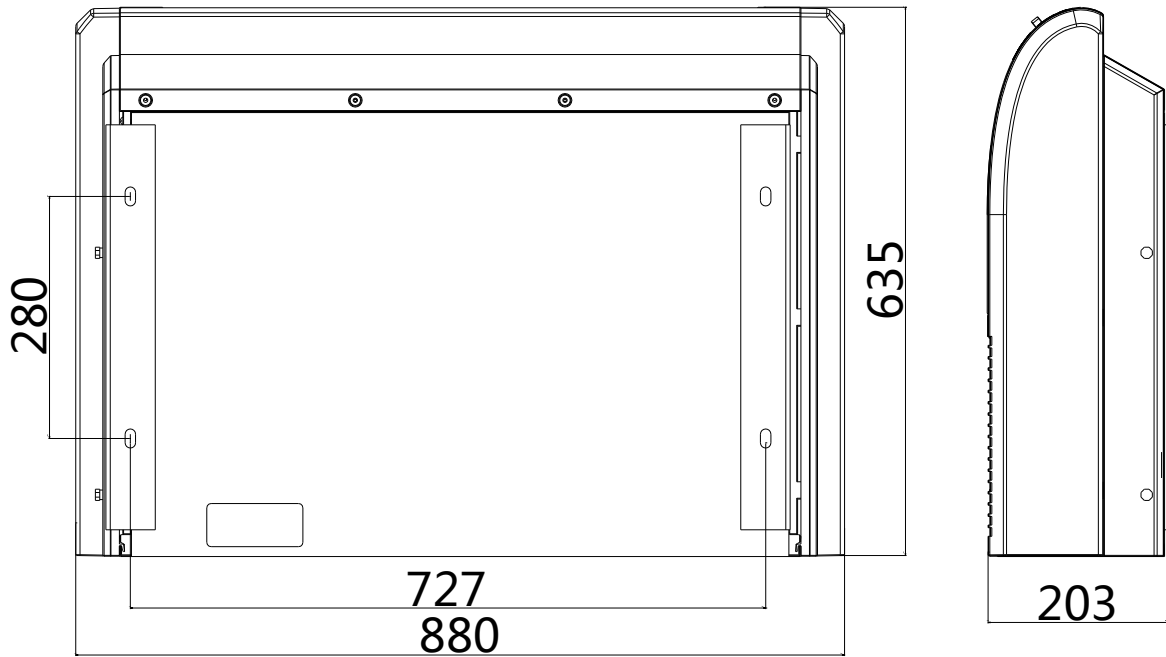

#### 3.2 SEFC024C3A, SEFC036C3A

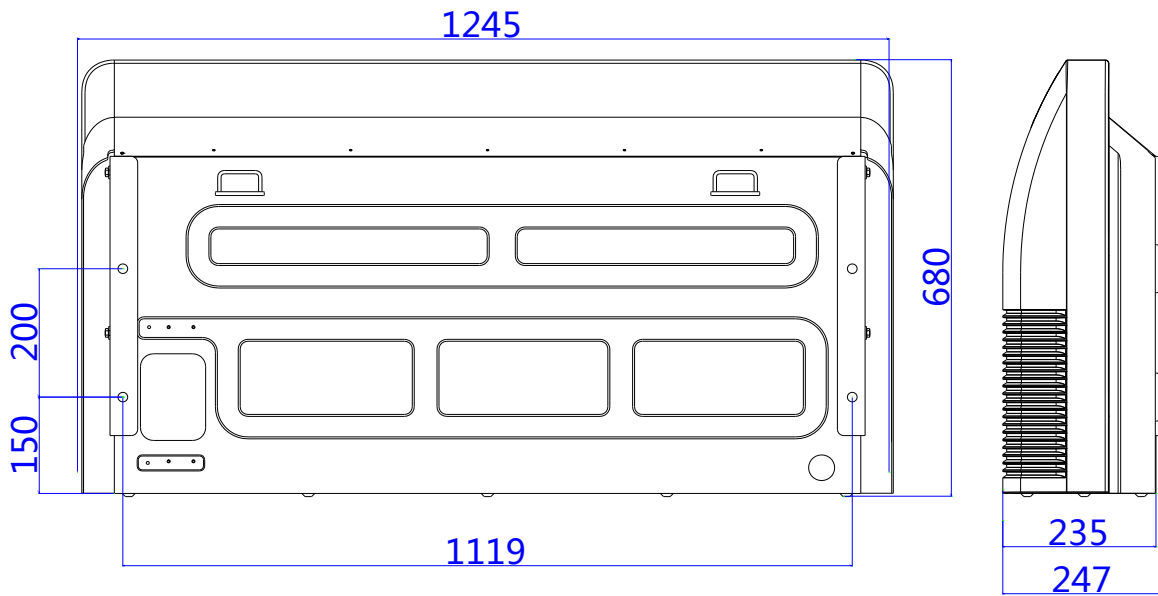



### 3.3 SEFC048C3A, SEFC060C3A

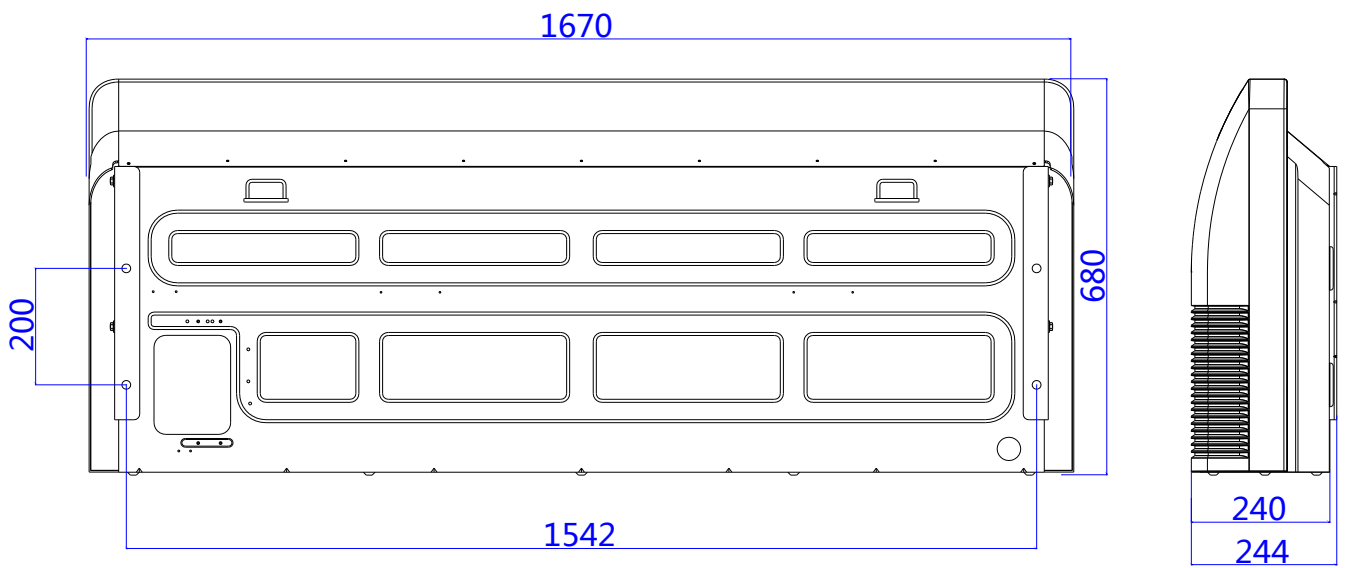

## 4.Service Space

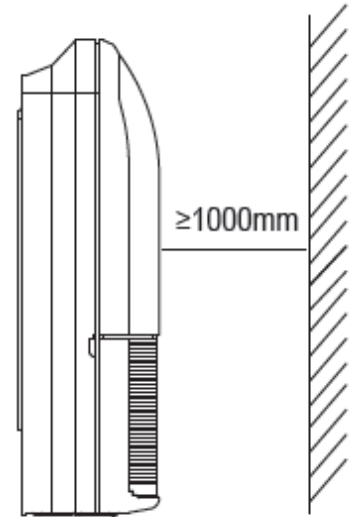
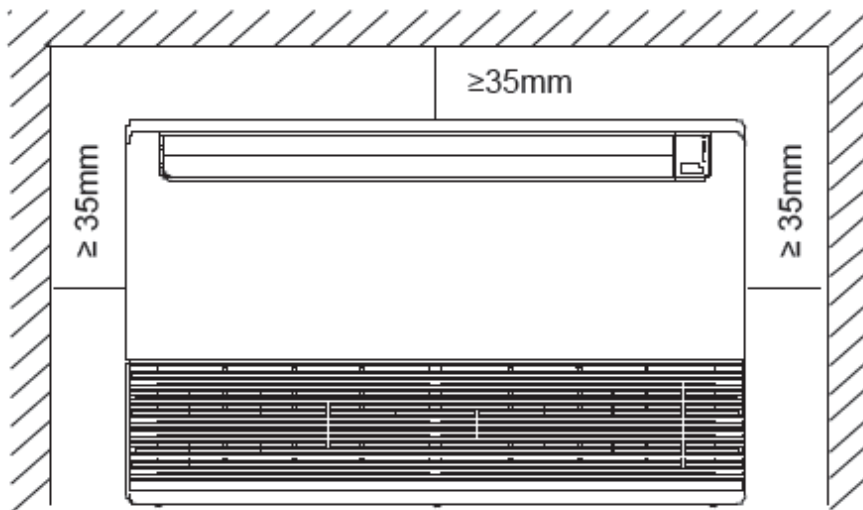

# 5.Wiring Diagrams

## 5.1 SEFC018C3A

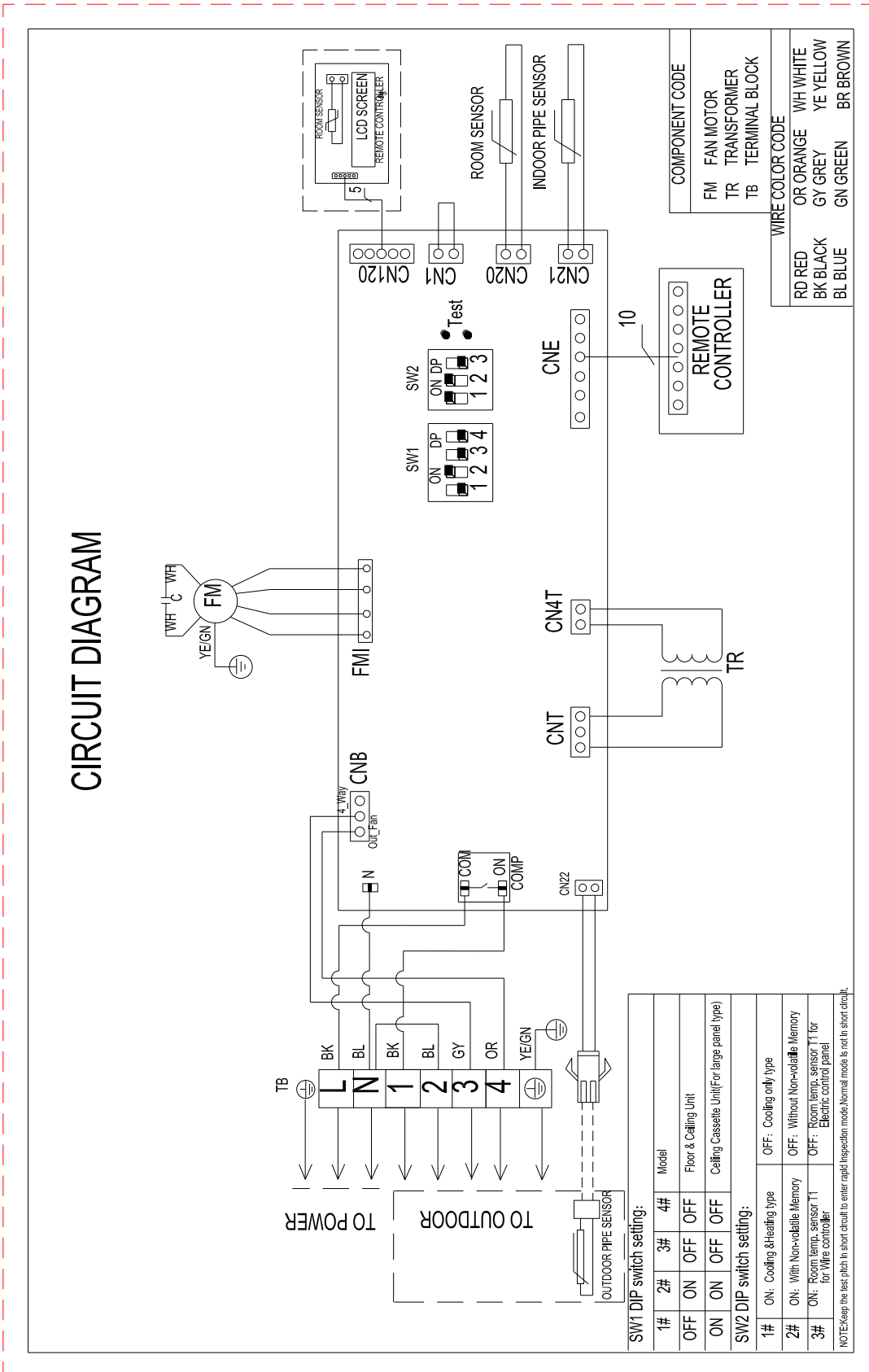

5.2 SEFC024C3A, SEFC036C3A,

CIRCUIT DIAGRAM

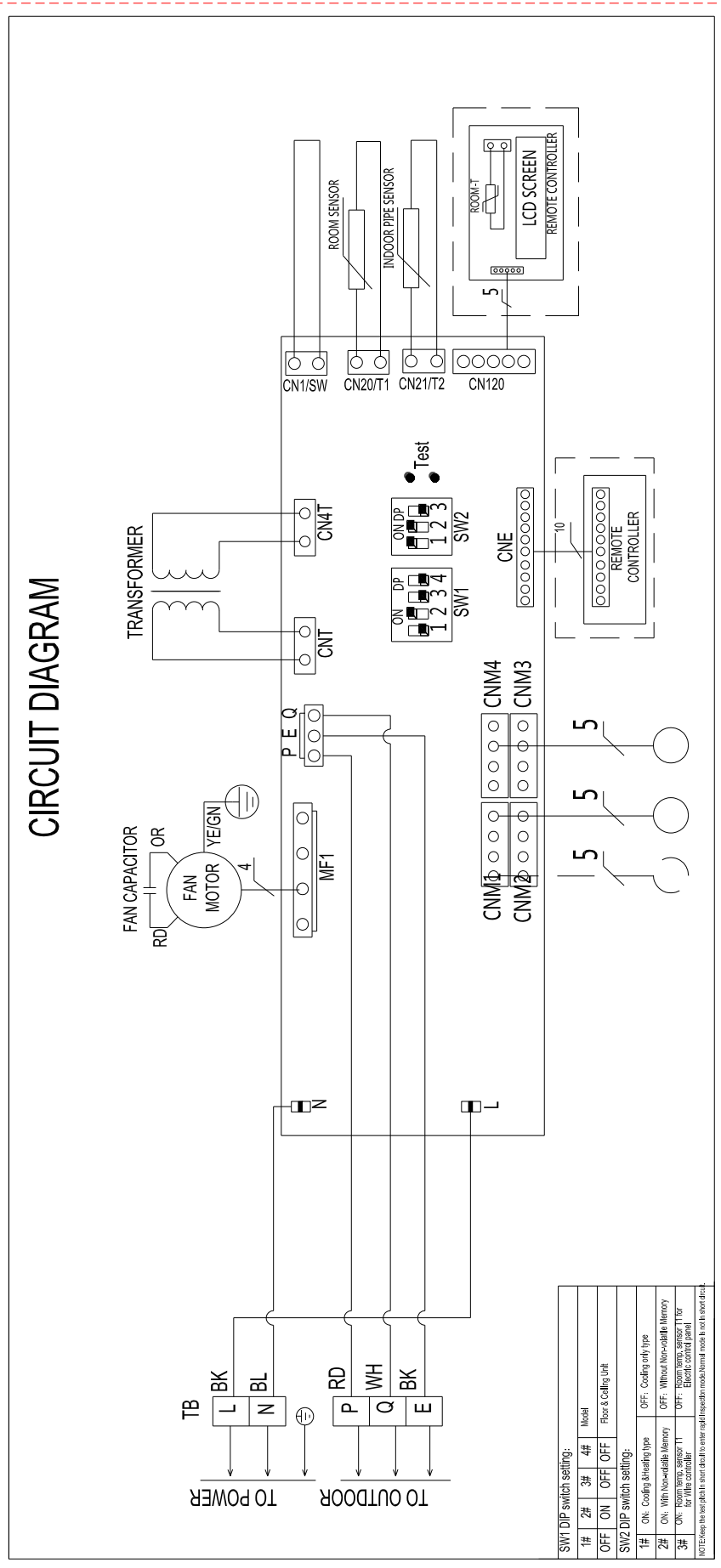

5.3 SEFC048C3A,SEFC060C3A

CIRCUIT DIAGRAM

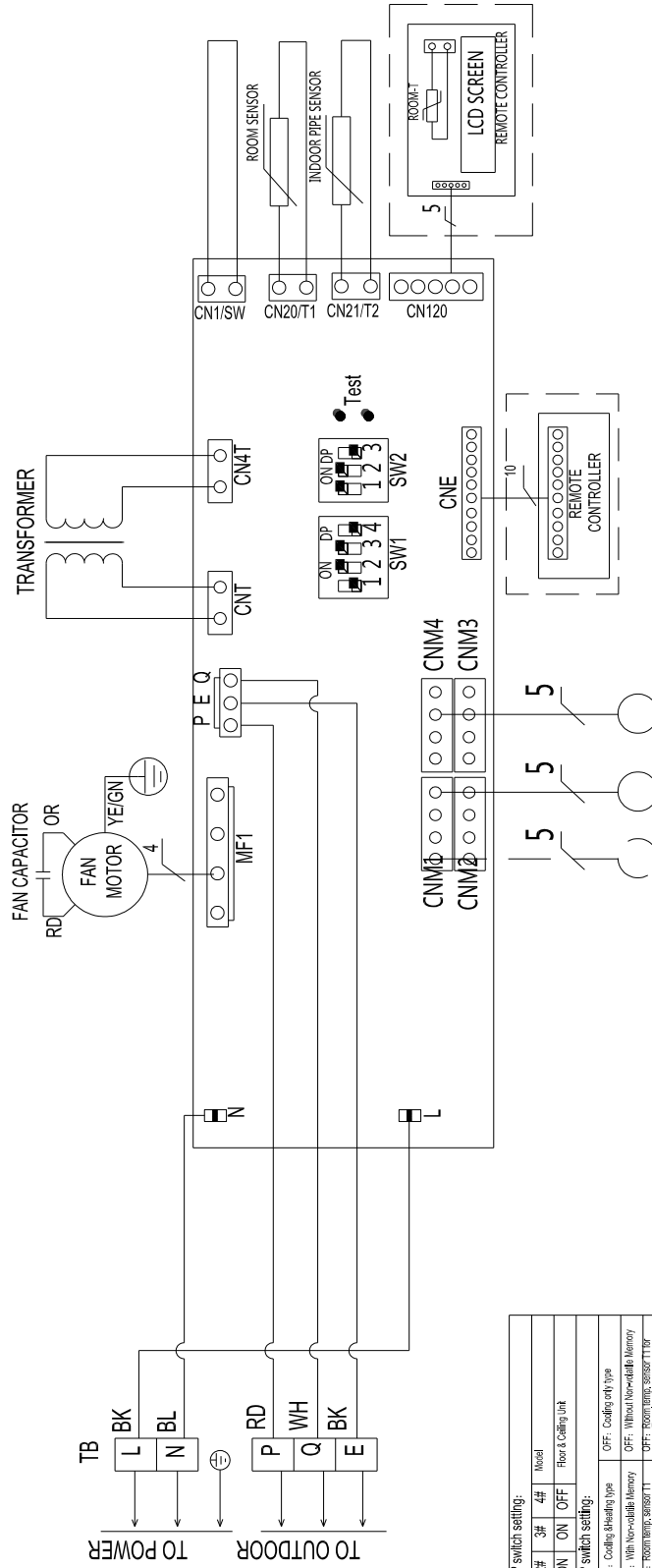

SW1 DIP switch setting:			
1#	2#	3#	4#
OFF	ON	OFF	OFF
Model			
Floor & Ceiling unit			

SW2 DIP switch setting:			
1#	2#	3#	4#
ON	ON	OFF	OFF
Model			
Floor & Ceiling unit			

NOTE: Keep the wire flat in your stick to wire and tighten the screw to avoid the wire from being damaged.

## 6.Capacity Table

### Cooling

#### 6.1 SEFC018C3A

MODEL		SEFC018C3A					
COOLING		OUTDOOR TEMPERATURE DRY					
Indoor Conditions		21°C	25°C	30°C	35°C	40°C	43°C
21°C D 15°C W	Total capacity kW	4.98	4.93	4.88	4.81	4.32	3.67
	Input kW.	1.76	1.79	1.83	1.89	2.00	2.08
24°C D 17°C W	Total capacity kW	5.23	5.18	5.12	5.05	4.53	3.85
	Input kW.	1.79	1.83	1.87	1.92	2.04	3.79
27°C D 19°C W	Total capacity kW	5.49	5.43	5.38	5.30	4.76	4.04
	Input kW.	1.83	1.86	1.90	1.96	2.08	2.16
29°C D 19°C W	Total capacity kW	5.71	5.65	5.60	5.51	4.95	4.21
	Input kW.	1.86	1.90	1.94	2.00	2.12	2.21
32°C D 23°C W	Total capacity kW	5.94	5.88	5.82	5.73	5.14	4.37
	Input kW.	1.90	1.94	1.98	2.04	2.16	2.25

#### 6.2 SEFC024C3A

MODEL		SEFC024C3A					
COOLING		OUTDOOR TEMPERATURE DRY					
Indoor Conditions		21°C	25°C	30°C	35°C	40°C	43°C
21°C D 15°C W	Total capacity kW	6.67	6.60	6.54	6.44	5.78	4.91
	Input kW.	2.29	2.33	2.38	2.45	2.60	2.71
24°C D 17°C W	Total capacity kW	7.00	6.93	6.86	6.76	6.07	5.16
	Input kW.	2.33	2.38	2.43	2.50	2.65	4.93
27°C D 19°C W	Total capacity kW	7.35	7.28	7.21	7.10	6.37	5.42
	Input kW.	2.38	2.42	2.48	2.55	2.71	2.82
29°C D 19°C W	Total capacity kW	7.65	7.57	7.50	7.38	6.63	5.63
	Input kW.	2.42	2.47	2.53	2.60	2.76	2.87
32°C D 23°C W	Total capacity kW	7.95	7.87	7.79	7.68	6.89	5.86
	Input kW.	2.47	2.53	2.57	2.65	2.82	2.93

#### 6.3 SEFC036C3A

MODEL		SEFC036C3A					
COOLING		OUTDOOR TEMPERATURE DRY					
Indoor Conditions		21°C	25°C	30°C	35°C	40°C	43°C
21°C D 15°C W	Total capacity kW	9.86	9.77	9.67	9.53	8.55	7.27
	Input kW.	3.68	3.75	3.83	3.94	4.19	4.35
24°C D 17°C W	Total capacity kW	10.36	10.25	10.15	10.00	8.98	7.63
	Input kW.	3.75	3.83	3.91	4.02	4.26	7.93
27°C D 19°C W	Total capacity kW	10.88	10.76	10.66	10.50	9.43	8.01
	Input kW.	3.83	3.90	3.98	4.10	4.35	4.53
29°C D 19°C W	Total capacity kW	11.31	11.20	11.09	10.92	9.80	8.33
	Input kW.	3.90	3.98	4.06	4.19	4.44	4.61
32°C D 23°C W	Total capacity kW	11.76	11.64	11.53	11.36	10.19	8.66
	Input kW.	3.98	4.06	4.14	4.26	4.53	4.71

**6.4 SEFC040C3A**

MODEL		SEFC048C3A					
COOLING		OUTDOOR TEMPERATURE DRY					
Indoor Conditions		21°C	25°C	30°C	35°C	40°C	43°C
21°C D 15°C W	Total capacity kW	13.15	13.02	12.89	12.70	11.40	9.69
	Input kW.	4.72	4.81	4.91	5.06	5.37	5.58
24°C D 17°C W	Total capacity kW	13.81	13.67	13.53	13.33	11.97	10.17
	Input kW.	4.81	4.91	5.01	5.16	5.47	10.17
27°C D 19°C W	Total capacity kW	14.50	14.35	14.21	14.00	12.57	10.68
	Input kW.	4.91	5.00	5.11	5.26	5.58	5.81
29°C D 19°C W	Total capacity kW	15.08	14.93	14.78	14.56	13.07	11.11
	Input kW.	5.00	5.10	5.21	5.37	5.69	5.92
32°C D 23°C W	Total capacity kW	15.68	15.52	15.37	15.14	13.59	11.55
	Input kW.	5.10	5.21	5.31	5.47	5.81	6.04

**6.5 SEFC060C3A**

MODEL		SEFC060C3A					
COOLING		OUTDOOR TEMPERATURE DRY					
Indoor Conditions		21°C	25°C	30°C	35°C	40°C	43°C
21°C D 15°C W	Total capacity kW	15.03	14.88	14.73	14.51	13.03	11.07
	Input kW.	5.35	5.45	5.56	5.73	6.08	6.32
24°C D 17°C W	Total capacity kW	15.78	15.62	15.46	15.23	13.68	11.62
	Input kW.	5.45	5.56	5.68	5.85	6.20	11.52
27°C D 19°C W	Total capacity kW	16.57	16.40	16.24	16.00	14.37	12.21
	Input kW.	5.56	5.67	5.79	5.96	6.32	6.58
29°C D 19°C W	Total capacity kW	17.23	17.06	16.89	16.64	14.94	12.70
	Input kW.	5.67	5.78	5.90	6.08	6.45	6.71
32°C D 23°C W	Total capacity kW	17.92	17.74	17.57	17.30	15.53	13.20
	Input kW.	5.78	5.90	6.02	6.20	6.58	6.84

## Heating

### 6.6 SEFC018C3A

MODEL		SSEFC018C3AEFC018C3A						
Indoor Conditions		24°C DB 18°C WB	12°C DB 11°C WB	7°C DB 6°C WB	4°C DB 3°C WB	0°C DB -1°C WB	-5°C DB -6°C WB	-7°C DB -8°C WB
15°C	Capacity kW	6.62	6.49	6.40	6.09	5.88	5.41	5.13
	Input kW.	1.71	1.75	1.78	1.79	1.81	1.82	1.83
18°C	Capacity kW	6.31	6.18	6.09	5.80	5.60	5.16	4.88
	Input kW.	1.74	1.78	1.81	1.83	1.84	1.86	1.87
20°C	Capacity kW	6.01	5.89	5.80	5.52	5.33	4.91	4.65
	Input kW.	1.77	1.82	1.85	1.87	1.88	1.90	1.91
22°C	Capacity kW	5.72	5.61	5.53	5.26	5.08	4.67	4.43
	Input kW.	1.81	1.85	1.89	1.91	1.92	1.94	1.94
27°C	Capacity kW	5.45	5.34	5.26	5.01	4.84	4.45	4.22
	Input kW.	1.84	1.89	1.93	1.94	1.95	1.97	1.98

### 6.7 SEFC024C3A

MODEL		SESEFC024C3AFC024C3A						
Indoor Conditions		24°C DB 18°C WB	12°C DB 11°C WB	7°C DB 6°C WB	4°C DB 3°C WB	0°C DB -1°C WB	-5°C DB -6°C WB	-7°C DB -8°C WB
15°C	Capacity kW	8.68	8.51	8.38	7.98	7.71	7.09	6.72
	Input kW.	2.07	2.12	2.16	2.18	2.20	2.22	2.23
18°C	Capacity kW	8.27	8.10	7.98	7.60	7.34	6.76	6.40
	Input kW.	2.12	2.17	2.20	2.23	2.24	2.26	2.27
20°C	Capacity kW	7.87	7.72	7.60	7.24	6.99	6.43	6.10
	Input kW.	2.16	2.21	2.25	2.27	2.28	2.31	2.32
22°C	Capacity kW	7.50	7.35	7.24	6.89	6.66	6.13	5.81
	Input kW.	2.20	2.25	2.30	2.32	2.33	2.35	2.36
27°C	Capacity kW	7.14	7.00	6.90	6.56	6.34	5.84	5.53
	Input kW.	2.24	2.30	2.34	2.36	2.38	2.40	2.41

### 6.8 SEFC036C3A

MODEL		SEFC036C3ASEFC036C3A						
Indoor Conditions		24°C DB 18°C WB	12°C DB 11°C WB	7°C DB 6°C WB	4°C DB 3°C WB	0°C DB -1°C WB	-5°C DB -6°C WB	-7°C DB -8°C WB
15°C	Capacity kW	13.01	12.76	12.57	11.96	11.56	10.64	10.08
	Input kW.	3.59	3.68	3.75	3.78	3.81	3.84	3.86
18°C	Capacity kW	12.40	12.15	11.97	11.39	11.01	10.13	9.60
	Input kW.	3.67	3.75	3.82	3.86	3.88	3.92	3.94
20°C	Capacity kW	11.81	11.57	11.40	10.85	10.49	9.65	9.14
	Input kW.	3.74	3.83	3.90	3.94	3.96	4.00	4.02
22°C	Capacity kW	11.24	11.02	10.86	10.34	9.98	9.19	8.71
	Input kW.	3.82	3.91	3.98	4.02	4.04	4.08	4.10
27°C	Capacity kW	10.71	10.49	10.34	9.84	9.51	8.75	8.30
	Input kW.	3.89	3.99	4.06	4.10	4.12	4.16	4.18



**6.9 SEFC048C3A**

MODEL		SEFC048C3ASEFC048C3A						
Indoor Conditions		24°C DB 18°C WB	12°C DB 11°C WB	7°C DB 6°C WB	4°C DB 3°C WB	0°C DB -1°C WB	-5°C DB -6°C WB	-7°C DB -8°C WB
15°C	Capacity kW	17.35	17.01	16.76	15.95	15.41	14.18	13.44
	Input kW.	4.94	5.06	5.15	5.2	5.23	5.28	5.31
18°C	Capacity kW	16.53	16.2	15.96	15.19	14.68	13.51	12.8
	Input kW.	5.04	5.16	5.25	5.31	5.33	5.39	5.41
20°C	Capacity kW	15.74	15.43	15.2	14.47	13.98	12.86	12.19
	Input kW.	5.14	5.26	5.36	5.41	5.44	5.5	5.52
22°C	Capacity kW	14.99	14.69	14.48	13.78	13.31	12.25	11.61
	Input kW.	5.25	5.37	5.47	5.52	5.55	5.61	5.63
27°C	Capacity kW	14.28	13.99	13.79	13.12	12.68	11.67	11.06
	Input kW.	5.34	5.48	5.58	5.63	5.66	5.72	5.75

**6.10 SEFC060C3A**

MODEL		SEFC060C3ASEFC060C3A						
Indoor Conditions		24°C DB 18°CWB	12°C DB 11°CWB	7°C DB 6°C WB	4°C DB 3°C WB	0°C DB -1°C WB	-5°C DB -6°C WB	-7°C DB -8°C WB
15°C	Capacity kW	18.26	17.91	17.64	16.79	16.22	14.93	14.15
	Input kW.	5.59	5.72	5.82	5.88	5.91	5.97	6.00
18°C	Capacity kW	17.40	17.05	16.80	15.99	15.45	14.22	13.47
	Input kW.	5.70	5.83	5.94	6.00	6.03	6.09	6.12
20°C	Capacity kW	16.57	16.24	16.00	15.23	14.72	13.54	12.83
	Input kW.	5.81	5.95	6.06	6.12	6.15	6.22	6.24
22°C	Capacity kW	15.78	15.46	15.24	14.51	14.01	12.89	12.22
	Input kW.	5.94	6.07	6.18	6.24	6.27	6.34	6.37
27°C	Capacity kW	15.03	14.73	14.52	13.81	13.35	12.28	11.64
	Input kW.	6.04	6.20	6.31	6.37	6.40	6.47	6.50

## 7. Electric Characteristics

Model	Indoor Units				Indoor Fan Motor
	Hz	Voltage	Min.	Max.	kW
SEFC018C3A	50	220-240V	198	254	0.13
SEFC024C3A	50	220-240V	198	254	0.15
SEFC036C3A	50	220-240V	198	254	0.30
SEFC048C3A	50	220-240V	198	254	0.26
SEFC060C3A	50	220-240V	198	254	0.26

## 8.Sound Levels

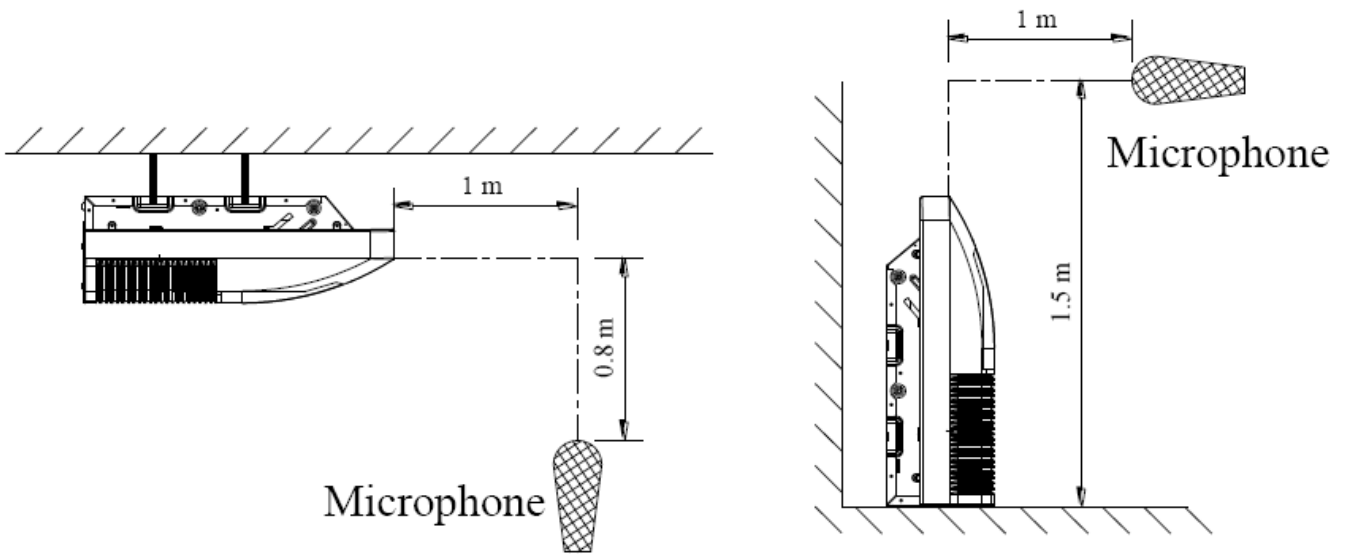

Model		SEFC018C3A	SEFC024C3A(RS485)	SEFC048C3A(RS485)
noise level	dB(A)	44~52	39~48	44~52
Model		CUA-48HR1(RS485)	CUA-60HR1(RS485)	/
noise level	dB(A)	48~57	48~57	/

## 9.Exploded View

### 9.1 SEFC018C3A

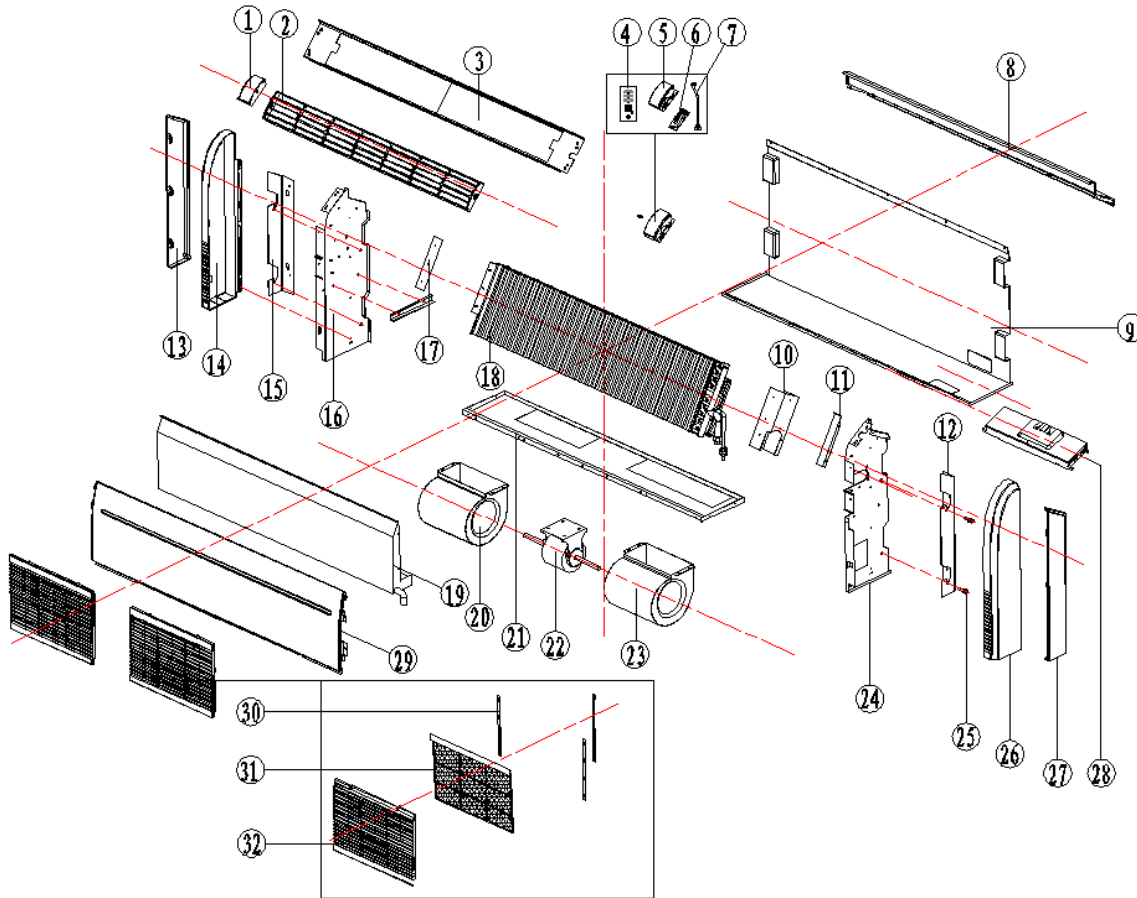

No.	Part Name	Quantity	No.	Part Name	Quantity
1	70 wind guide connected board assy B	1	22	indoor fan motor	1
2	Wind guide frame assy	2	23	Fan wheel(right)	1
3	Air outlet support	1	24	Right side board	2
4	Display film	1	25	Hexagon headed bolt	4
5	Display panel	1	26	Right cover	4
8	Top Cover	1	27	Right accessories	1
9	Weld assembly for rear panel	1	28	Indoor e-part box assembly	1
10	Evaporator right fixed plate	1	28.1	Electric box	1
11	Evaporator right positioning plate	1	28.2	Indoor PCB	1
12	Right mounting support	1	28.3	Temperature sensors (indoor)	1
13	Left accessories	1	28.4	Temperature sensor (evaporator)	1
14	Left cover	1	28.5	Transformer	1
15	Left mounting support	1	28.6	Terminal	1
16	Left side board	1	28.7	Display lamp panel	1
17	Evaporator left positioning plate	1	29	Front panel component	1
18	Evaporator assy	1	30	70 filter mould layer 2	1
19	Water pan components	1	31	70 filter	2
20	Fan wheel(left)	1	32	70 grille	2
21	Weld assembly for fan wheel mounting plate	1			

### 9.2 SEFC024C3A, SEFC036C3A

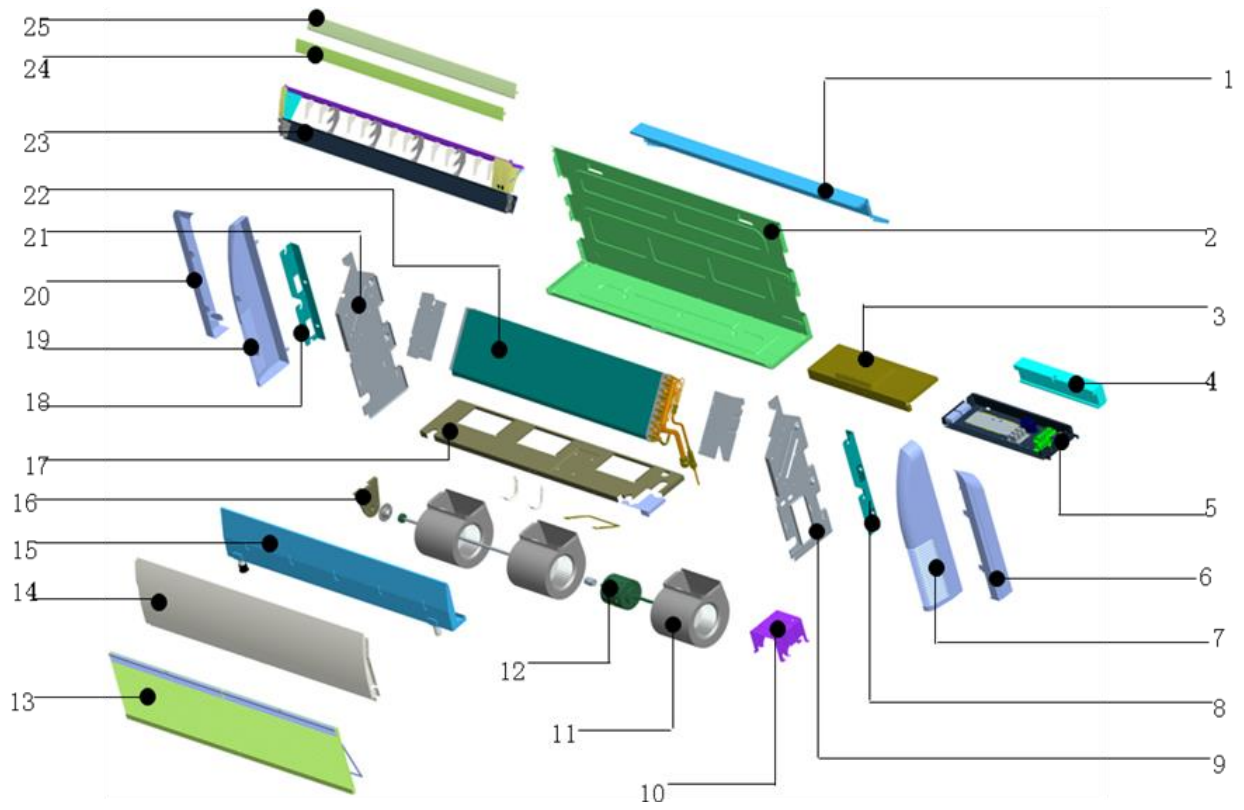





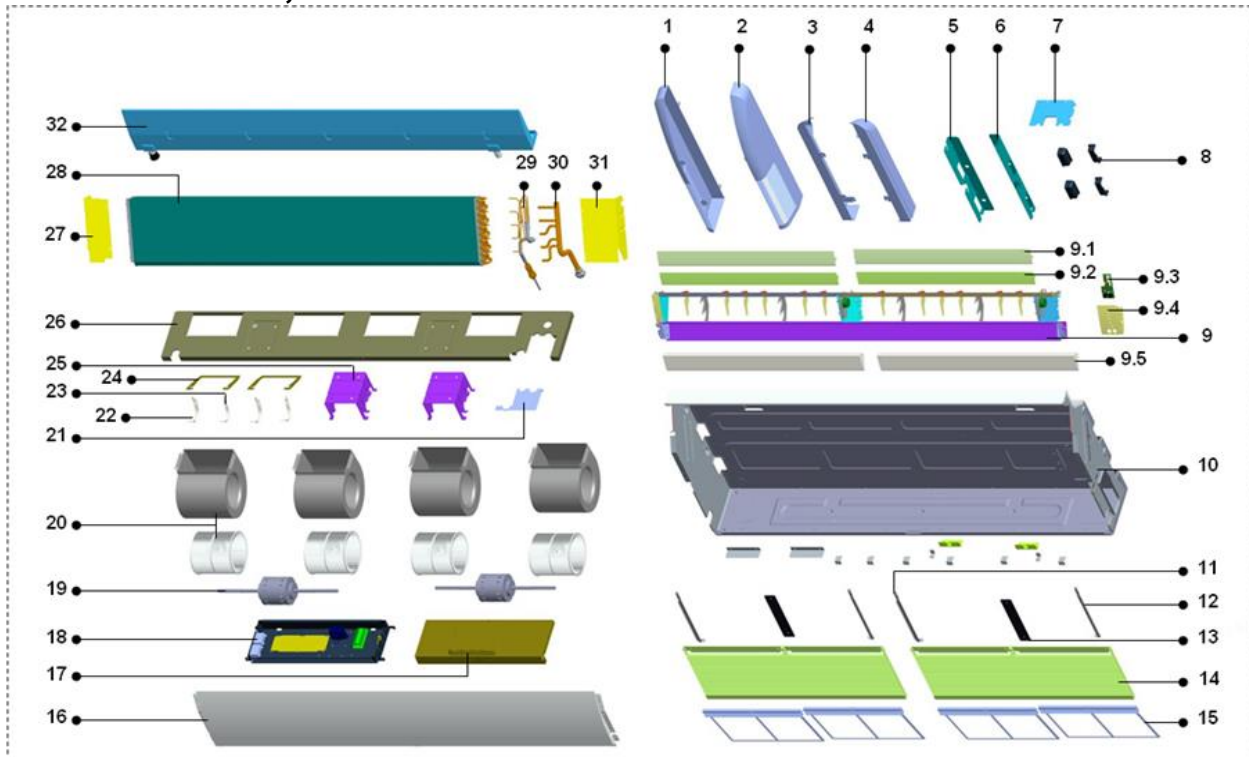

No.	Part Name	Quantity	No.	Part Name	Quantity
1	Rear cover	1	20	Right seal plate	1
2	Chassis assembly	1	21	Right separating board	1
3	E-part box cover	1	22	Evaporator component	1
4	E-part box mat	1	22.1	Left mounting plate of evaporator	1
5	Indoor PCB assembly	1	22.2	Shunt capillary assembly	1
5.1	E-part box	1	22.3	Distributor	1
5.2	Indoor PCB	1	22.4	Air inlet header pipe assembly of evaporator	1
5.3	Fan capacitor	1	22.5	Single Connector	1
5.4	Transformer	1	22.6	Evaporator assembly	1
5.5	Temperature sensors (indoor)	1	22.7	Right mounting plate of evaporator	1
5.6	Terminal	1	22.8	Temperature sensors (evaporator)	1
6	Left seal plate	1	23	Air-out frame component	1
7	Left cover	1	23.1	Fixing board assembly for air-out frame	1
8	Left hoisting plate	1	23.2	Display film	1
9	Left separating board I	1	23.3	Display lamp panel	1
10	Motor separating board	1	23.4	Vertical step motor	1
11	Wheel volute for slim type	3	23.5	Horizontal step motor	1
12	Indoor fan motor	1	23.6	End bearing of louver	2
13	Air inlet grille	2	23.7	Intermediate bearing of louver	8
14	Top Cover assembly	1	23.8	Driving lever for louver	1
15	Weld assembly of Water drain pan	1	23.9	Follower lever for louver	1
15.1	Water outlet rubber cover	1	23.10	Louver holder	1
16	Supporting board for motor	1	23.11	Guard vane	10
17	Weld assembly for intermediate transverse girder	1	24	Upper horizontal louver	1
18	Right mounting plate of evaporator	1	25	Down horizontal louver	1
19	Right cover	1			

### 9.3 SEFC048C3A, SEFC060C3A



No.	Part Name	Quantity	No.	Part Name	Quantity
1	Right cover	1	16	top Cover assembly	1
2	Left cover	1	17	electric box cover	1
3	Right seal plate	1	18	indoor PCB assembly	1
4	left seal plate	1	18.1	electric box	1
5	Right hoisting plate	1	18.2	indoor PCB	1
6	Left hoisting pate	1	18.3	fan capacitor	2
7	Rat guard	1	18.4	temperature sensors (indoor)	1
8	Handle	4	18.5	temperature sensors (evaporator)	1
9	Air out frame assy	1	18.6	transformer	1
9.1	Horizontal louver, up	2	18.7	terminal	1
9.2	Horizontal louver, down	2	19	indoor fan motor	2
9.3	display lamp panel	1	20	wheel volute for slim type	4
9.4	display panel Installing box	1	21	pipe clamp	1
9.5	Foam for air outlet frame	2	22	left gland for motor shaft sleeve	2
9.6	vertical step motor	1	23	right gland for motor shaft sleeve	2
9.7	horizontal step motor 1	1	24	Motor separating board	2
9.8	horizontal step motor	1	25	Holder for fan motor	2
9.9	display film	1	26	weld assembly for intermediate transverse girder	1
9.10	End bearing of louver	4	27	right mounting plate of evaporator	1
9.11	intermediate bearing of louver	8	28	evaporator	1
9.12	driving lever for louver	2	29	shunt capillary assembly	1
9.13	follower lever for louver	2	29.1		1
9.14	Louver holder	2	29.2	distributor	1
9.15	Guard vane	12	30	air inlet header pipe assembly of evaporator	1
10	Chassis	1	30.1	Single Connector	1
11	left retaining plate	2	31	left mounting plate of evaporator	1
12	right retaining plate	2	32	weld assembly of Water drain pan	1
13	filter snap-gauge	2	32.1	water outlet rubber cover	1
14	air inlet grille	2	33	remote controller	1
15	Filter	4			

## 10.Accessories

	Name	Shape	Quantity
Installation fittings	1.Hanging arm		2
	2. Remote controller		1
Controller	3. Remote controller holder (optional)		1
	4. Wire controller (optional)		1
	5. Mounting screw (ST2.9×10-C-H)		2
	6. Alkaline dry batteries (AM4)		2
Others	7. Installation & operation instruction manual		1



## 11.The Specification of Power

Model		18kBtu/h	24kBtu/h	36kBtu/h
Indoor power supply	V/Ph/Hz	220~240/1/50		
Outdoor power supply	V/Ph/Hz	220~240/1/50		
Connection wiring	Outdoor Power Supply	From indoor unit	Power supply individually for indoor and outdoor	
	Power wiring	mm <sup>2</sup>	3×2.5	3×2.5/3×1.0 3×4.0/3×1.0
	Signal wiring	mm <sup>2</sup>	5×1.5	RS485 twisted shielded wire pair 2×0.5

Model		36kBtu/h	48kBtu/h	60kBtu/h
Indoor power supply	V/Ph/Hz	220~240/1/50		
Outdoor power supply	V/Ph/Hz	380~415/3/50		
Connection wiring	Outdoor Power Supply	Power supply individually for indoor and outdoor		
	Power wiring	mm <sup>2</sup>	5×1.5/3×1.0 5×1.5/3×1.0	5×2.5/3×1.0
	Signal wiring	mm <sup>2</sup>	RS485 twisted shielded wire pair 2×0.5	

## 12. Field Wiring

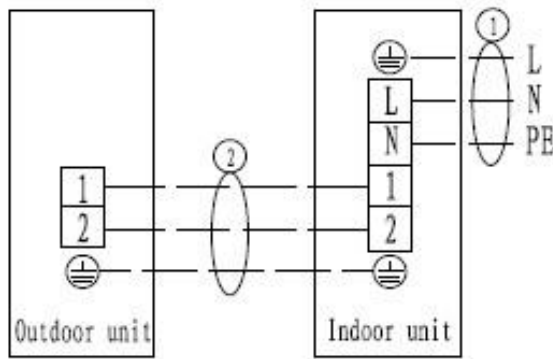

**Fig 1**  
Applicable for 9K~18K cooling only type

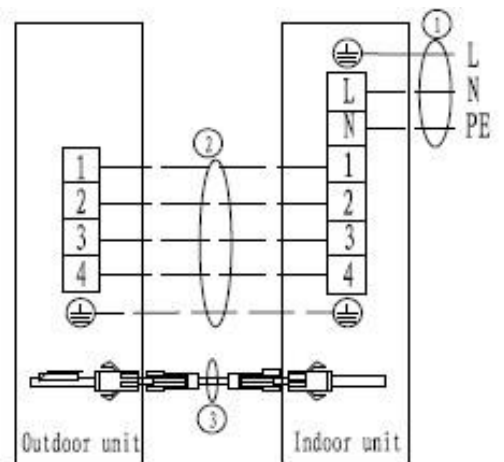

**Fig 2**  
Applicable for 9K~18K heatpump type

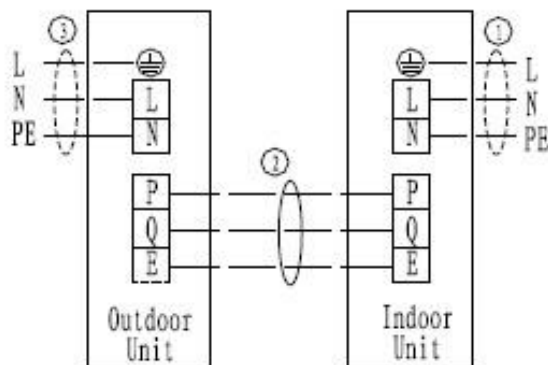

**Fig 3**  
Applicable for 24K, 36K single-phase cooling and heatpump type

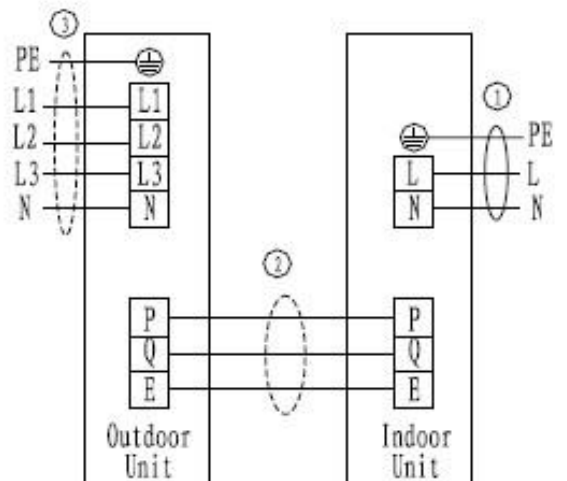

**Fig 4**  
Applicable for 24K, 36K, 48K, 60K three-phase cooling and heatpump type

## 13.Troubleshooting

**Fault code Table**

4LED Faults	Digital display	Failure description
Timer light flashing	E2	Ambient temperature sensor (T1) failure
Running light flashing	E3	Evaporator pipe temperature sensor (T2) failure
Defrost light flashing	E5	Condenser pipe temperature sensor (T3) failure
Warning light flashing	F5	Water full filled protection
Running light, defrost light flashing	E1	Indoor unit and wire controller communication failure
Running light, timer light flashing	P6	Indoor unit EEPROM failure
Defrost light, timer light flashing	F0	Indoor fan stall protection
Defrost light, warning light flashing	F2	Outdoor protection
Timer light, warning light flashing	E0	Indoor unit and outdoor unit communication failure
Running light, defrost light, timer light flashing	F3	High pressure protection
Defrost light , timer light, warning light flashing	F4	Low pressure protection
Running light, timer light, warning light flashing	F8	Outdoor unit exhaust temperature over-high protection
Running light, defrost light, timer light, warning light flashing	F9	Three-phase electricity phase sequence failure
Note: the flashing frequency for all above indication lights is 1HZ.		

## Part 3 Outdoor Units

1.Specification .....	104
2.Dimensions .....	107
3.Service Space .....	109
4.Wiring Diagrams .....	110
5.Electric Characteristics .....	115
6.Operation Limits .....	116
7.Sound Levels .....	117
8.Exploded View .....	118
9.Troubleshooting.....	124

# 1.Specification

Model		SCHE012C3A	SCHE018C3A	SCHE024C3A	SCHE036C3A	
Outdoor power supply		V/Ph/Hz	220~240/1/50	220~240/1/50	220~240/1/50	
Cooling	Capacity	Btu/h	12000	18000	24000	36000
		KW	3.5	5.3	7.1	10.5
	Input	W	1240	1900	2400	3710
	Rated current	A	5.4	8.26	10.6	16.7
Heating	Capacity	Btu/h	13200	20000	26000	39000
		KW	3.9	5.9	7.7	11.5
	Input	W	1270	1690	2100	3310
	Rated current	A	5.5	7.35	9.2	15
Max. input consumption		W	1620	2500	2700	4800
Max. current		A	8.3	12.6	13.2	21.2
Compressor	Model		PA145G1C-4 FT1	ASH232SV-C 8LU	ASH264RV-C8 DU1	C-SBN301H5 D
	Type		ROTARY	ROTARY	ROTARY	SCROLL
	Brand		GMCC	HITACHI	HITACHI	SANYO
	Capacity	Btu/h	13136	18800	24000	36000
	Input	W	1210	1900	2200	3950
	Rated current(RLA)	A	5.5	8.8	9.95	19.2
	Locked rotor Amp(LRA)	A	27	40	49	112
	Thermal protector		Internal	Internal	Internal	Internal
	Capacitor	μF	30	60	55	60
	Refrigerant oil	ml	440	600	600	1700
Outdoor fan motor	Model		YDK-35-6A H	YDK-38-6B	YDK-60A-6F	YDK-200-6B
	Input	70	70	80	150	450
	Capacitor	2	2	2.5	4	10
	Speed	r/min	900	920	850	800
Outdoor coil	Number of rows		2	2	2	1
	Tube pitch(a) x row pitch(b)	mm	25x21.65	25x21.65	25x21.65	25x21.65
	Fin spacing	mm	1.7	1.7	1.8	1.4
	Fin type		Hydrophilic	Hydrophilic	Hydrophilic	Hydrophilic
	Tube outside dia. and type	mm	9.52	9.52	9.52	9.52
			inner grooved	inner grooved	inner grooved	inner grooved
Number of circuits		4	4	5	3	
Outdoor air flow(High speed)		m <sup>3</sup> /h	2000	2800	3800	6000
Outdoor noise level		dB(A)	55	53	58	65
Outdoor unit	Dimension(W*H*D)	mm	866x304x535	866x304x535	930x370x700	1070x400x995
	Packing(W*H*D)	mm	920x335x585	920x335x585	990x410x770	1145x475x1120

	Net/Gross weight	kg	36/38	41/43	52/56	92/100
Refrigerant type/quantity		g	R410A/1100	R410A/1200	R410A/1800	R410A/2100
Throttle part			capillary	capillary	capillary	capillary
Design pressure		MPa	4.0/1.2	4.0/1.2	4.0/1.2	4.0/1.2
Max pressure		MPa	4.0	4.0	4.5	4.5
Connection wiring	Power wiring	mm <sup>2</sup>	3×1.5	3×2.5	3×2.5/3×1.0	3×4.0/3×1.0
	Signal wiring	mm <sup>2</sup>	5×1.5	5×1.5	RS485 twisted shielded wire pair	
Refrigerant piping	Liquid side/Gas side	mm	φ6.35/φ12.7	φ6.35/φ12.7	φ9.52/φ15.88	φ9.52/φ19.05
	Max. pipe length	m	20	20	20	20
	Max. high drop	m	10	10	10	10
Ambient temp		°C	-7~43	-7~43	-7~43	-7~43
Stuffing Quantity		20'/40'/40' HQ	100/200/208	100/200/208	70/140/144	40/80/80

Model		SCHE036C7A	SCHE048C7A	SCHE060C7A	
Outdoor power supply		V/Ph/Hz	380~415/3/50	380~415/3/50	380~415/3/50
Cooling	Capacity	Btu/h	36000	48000	60000
		KW	10.5	14	16
	Input	W	3800	5000	5700
	Rated current	A	6.9	8.2	10
Heating	Capacity	Btu/h	39000	52000	60000
		KW	11.5	15.2	16
	Input	W	3600	5100	5800
	Rated current	A	6.5	8.4	10.2
Max. input consumption		W	4900	6000	6600
Max. current		A	10.3	10.5	11.8
Compressor	Model		C-SBN303H8D	C-SBN373H8D	C-SBN453H8D
	Type		SCROLL	SCROLL	SCROLL
	Brand		SANYO	SANYO	SANYO
	Capacity	Btu/h	36000	48100	56000
	Input	W	3650	4750	5750
	Rated current(RLA)	A	6.58	8.22	9.77
	Locked rotor Amp(LRA)	A	48	66	70
	Thermal protector		Internal	Internal	Internal
	Capacitor	μF	/	/	/
	Refrigerant oil	ml	1700	1700	1700

Outdoor fan motor	Model		YDK-200-6B	YDK-60-6P3-2	YDK-60-6P3-2
	Input	W	450	170*2	170*2
	Capacitor	$\mu$ F	10	4*2	4*2
	Speed	r/min	800	780	780
Outdoor coil	Number of rows		1	2	2
	Tube pitch(a) x row pitch(b)	mm	25x21.65	22x19.05	25x21.65
	Fin spacing	mm	1.4	1.6	1.6
	Fin type		Hydrophilic	Hydrophilic	Hydrophilic
	Tube outside dia. and type	mm	9.52	7.94	9.52
			inner grooved	inner grooved	inner grooved
	Number of circuits		3	7	7
Outdoor air flow(High speed)		m <sup>3</sup> /h	6000	6100	6100
Outdoor noise level		dB(A)	65	60	60
Outdoor unit	Dimension(W*H*D)	mm	1070x400x995	911x400x1335	911x400x1335
	Packing(W*H*D)	mm	1145x475x1120	964x402x1445	964x402x1445
	Net/Gross weight	kg	92/100	99/110	99/110
Refrigerant type/quantity		g	R410A/2100	R410A/3600	R410A/4000
Throttle part			capillary	capillary	capillary
Design pressure		MPa	4.0/1.2	4.0/1.2	4.0/1.2
Max pressure		MPa	4.5	4.5	4.5
Connection wiring	Power wiring	mm <sup>2</sup>	5x1.5/3x1.0	5x1.5/3x1.0	5x2.5/3x1.0
	Signal wiring	mm <sup>2</sup>	RS485 twisted shielded wire pair		
Refrigerant piping	Liquid side/Gas side	mm	$\Phi$ 9.52/ $\Phi$ 19.05	$\Phi$ 9.52/ $\Phi$ 19.05	$\Phi$ 9.52/ $\Phi$ 19.05
	Max. pipe length	m	20	20	20
	Max. high drop	m	10	10	10
Ambient temp		°C	-7~43	-7~43	-7~43
Stuffing Quantity		20'/40'/40'HQ	40/80/80	32/64/64	32/64/64

## 2. Dimensions

### 2.1 SCHE012C3A, SCHE018C3A

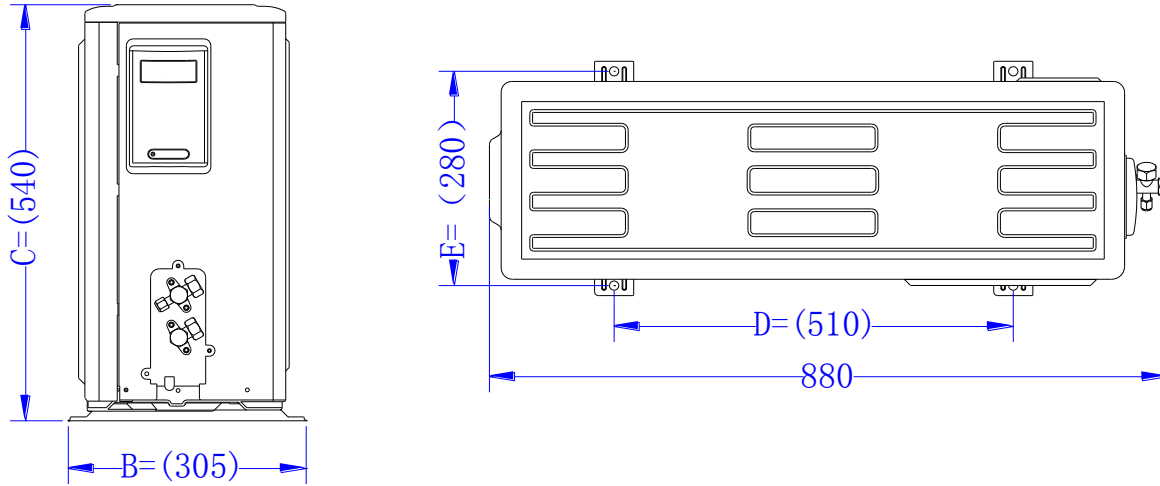

### 2.2 SCHE024C3A

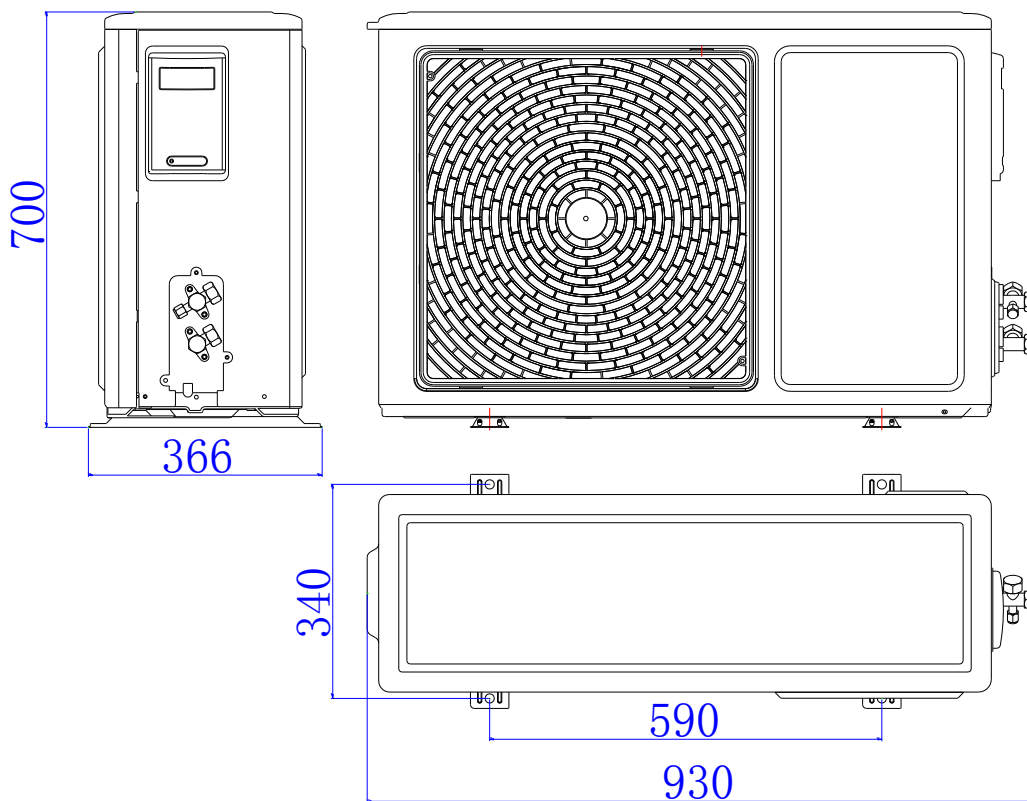



### 2.3 SCHE036C3A, SCHE036C7A

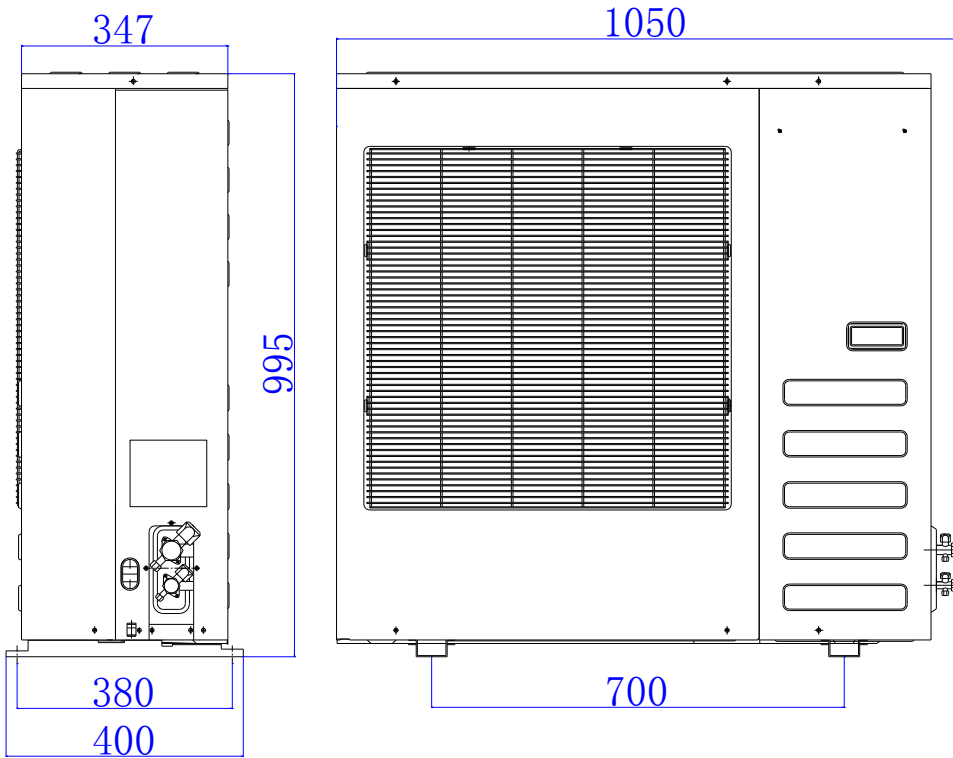

### 2.4 SCHE048C7A, SCHE060C7A

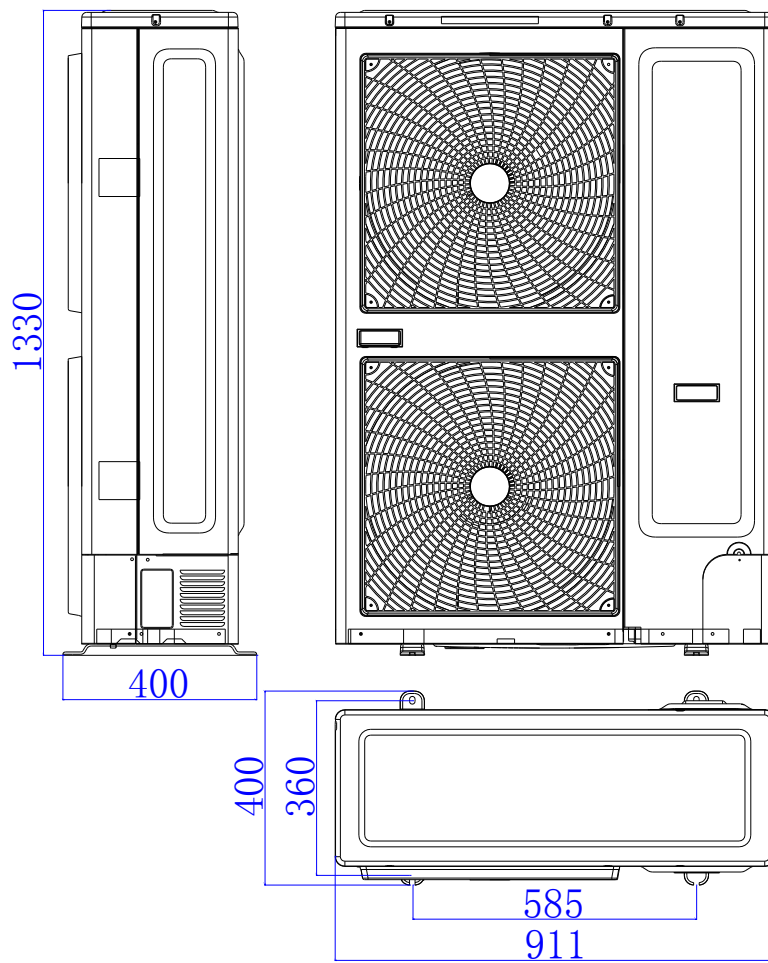

### 3.Service Space

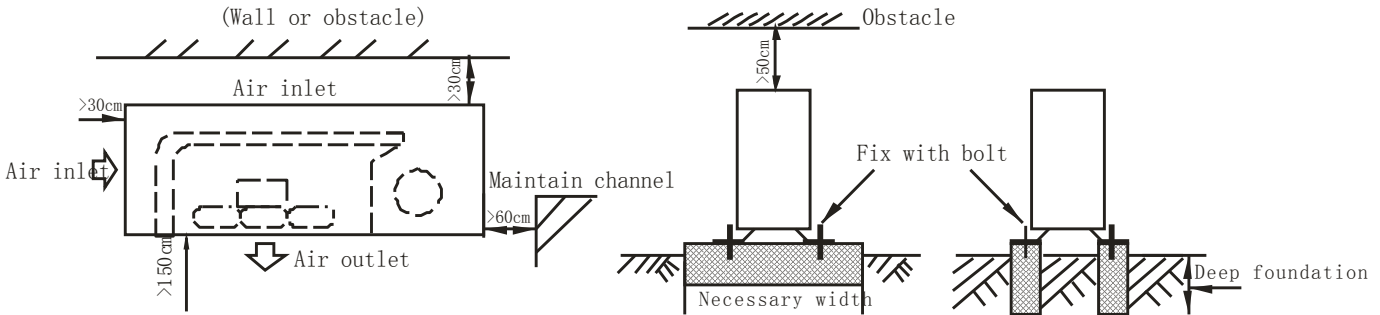

300mm is necessary between 2 outdoor units

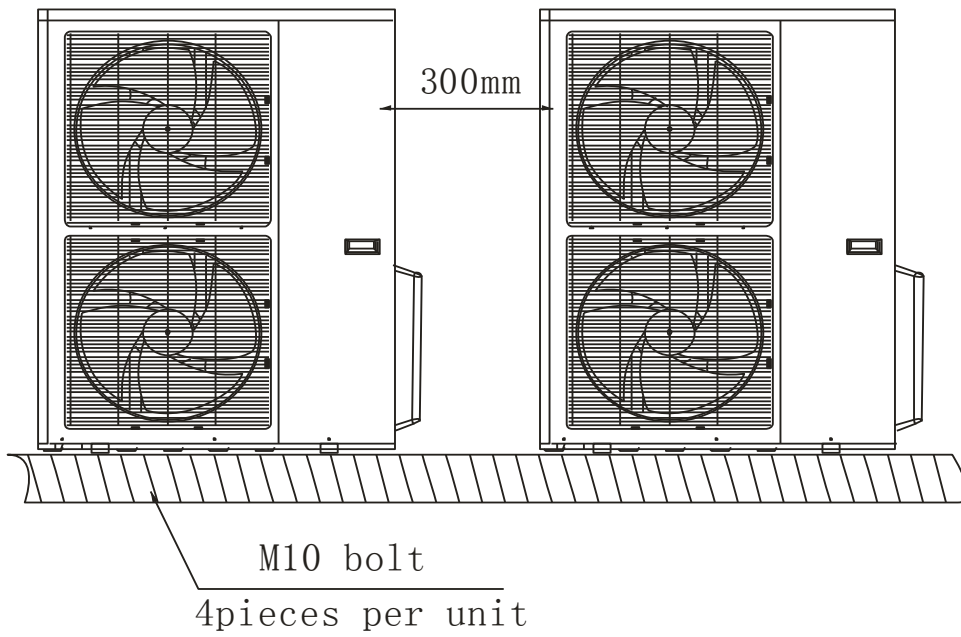

### 4. Wiring Diagrams

#### 4.1 SCHE012C3A, SCHE018C3A ( Power supply from indoor unit)

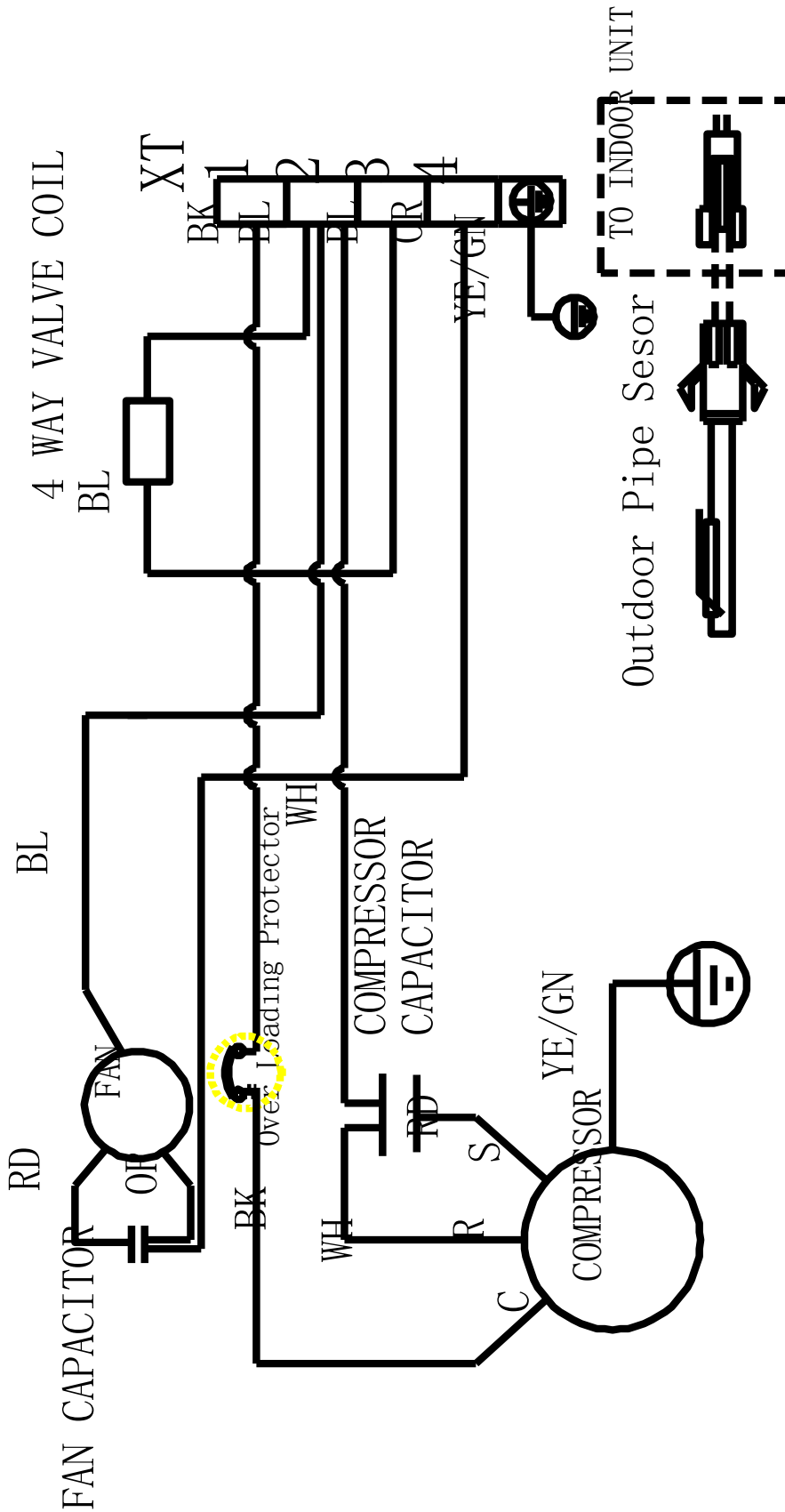

## 4.2 SCHE024C3A (Power supply independently)

CIRCUIT DIAGRAM

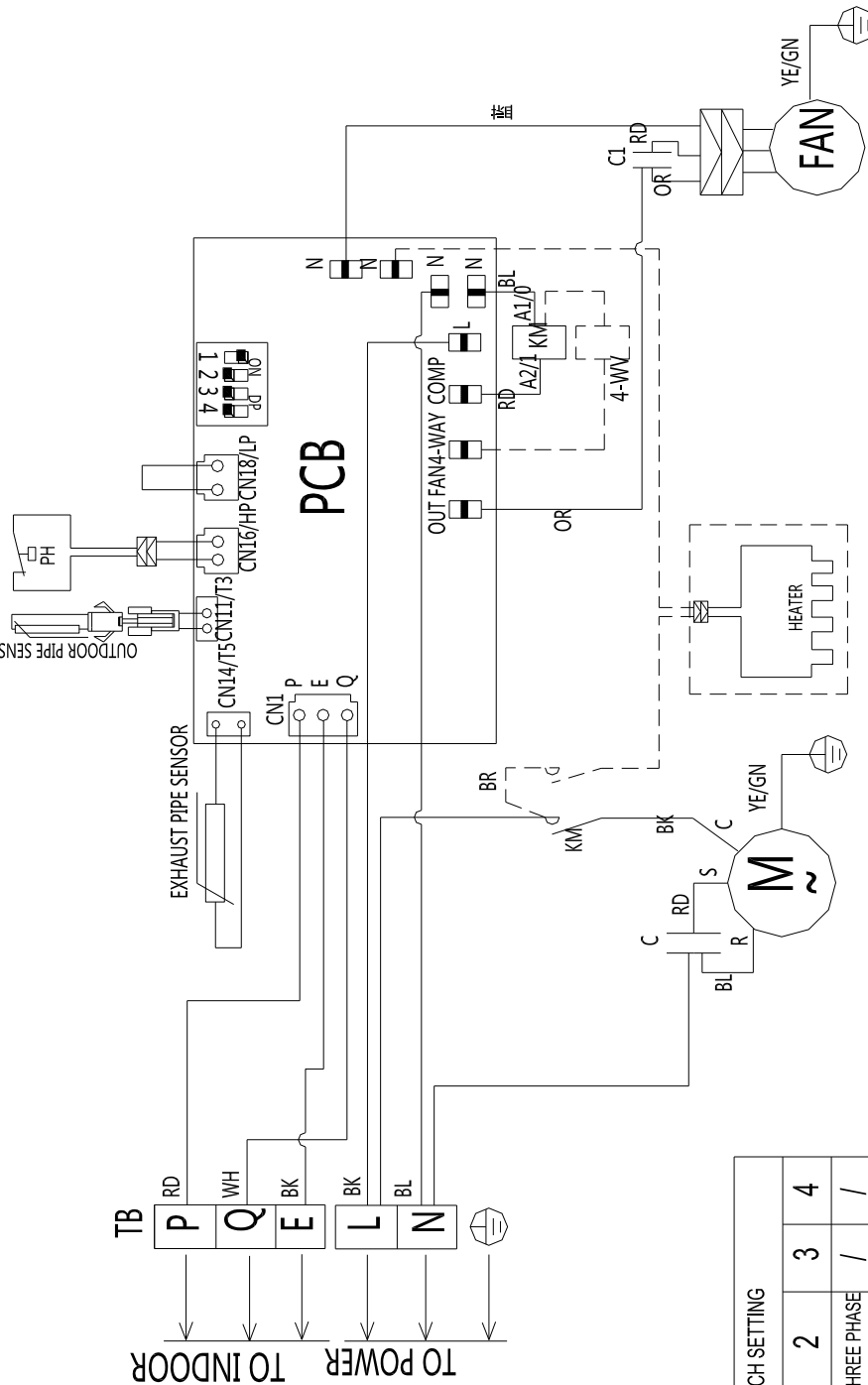

SWITCH SETTING				
SWITCH STATE	1	2	3	4
ON	/	THREE PHASE	/	/
OFF	/	SINGLE-PHASE	/	/

WIRE COLOR CODE

RD RED	OR ORANGE	WH WHITE
BK BLACK	GY GREY	YE YELLOW
BL BLUE	GN GREEN	BR BROWN
PR PURPLE		

WIRE INFORMATION

_____	FACTORY CONNECTION
_____	PROJECT CONNECTION
_____	PRACTICALITY EXTERIOR
_____	DASHED CIRCLE

Showing the part chosen in the actual installation

NOTES

1. The units should use unattached power switch, stated-cross-section wires and matching-spec. breaker.
2. Use the fuse within the specified scope, it can not replaced by iron wires or brass wires.
3. The units should install the stated-cross-section earth wire and keep it grounding unfaillingly.

COMPONENT CODE

KM	CONTACTOR
C	CAPACITOR
M	COMPRESSOR
TB	TERMINAL BLOCK
FM	FAN MOTOR
PH	HIGH PRESSURE SWITCH
4-WV	4-WAY VALVE COIL

DATE	DWG.NO.	N.O.
2013-08-02	CE56R1W1N00R08501P04-4	0

### 4.3 SCHE036C3A (Power supply independently)

## CIRCUIT DIAGRAM

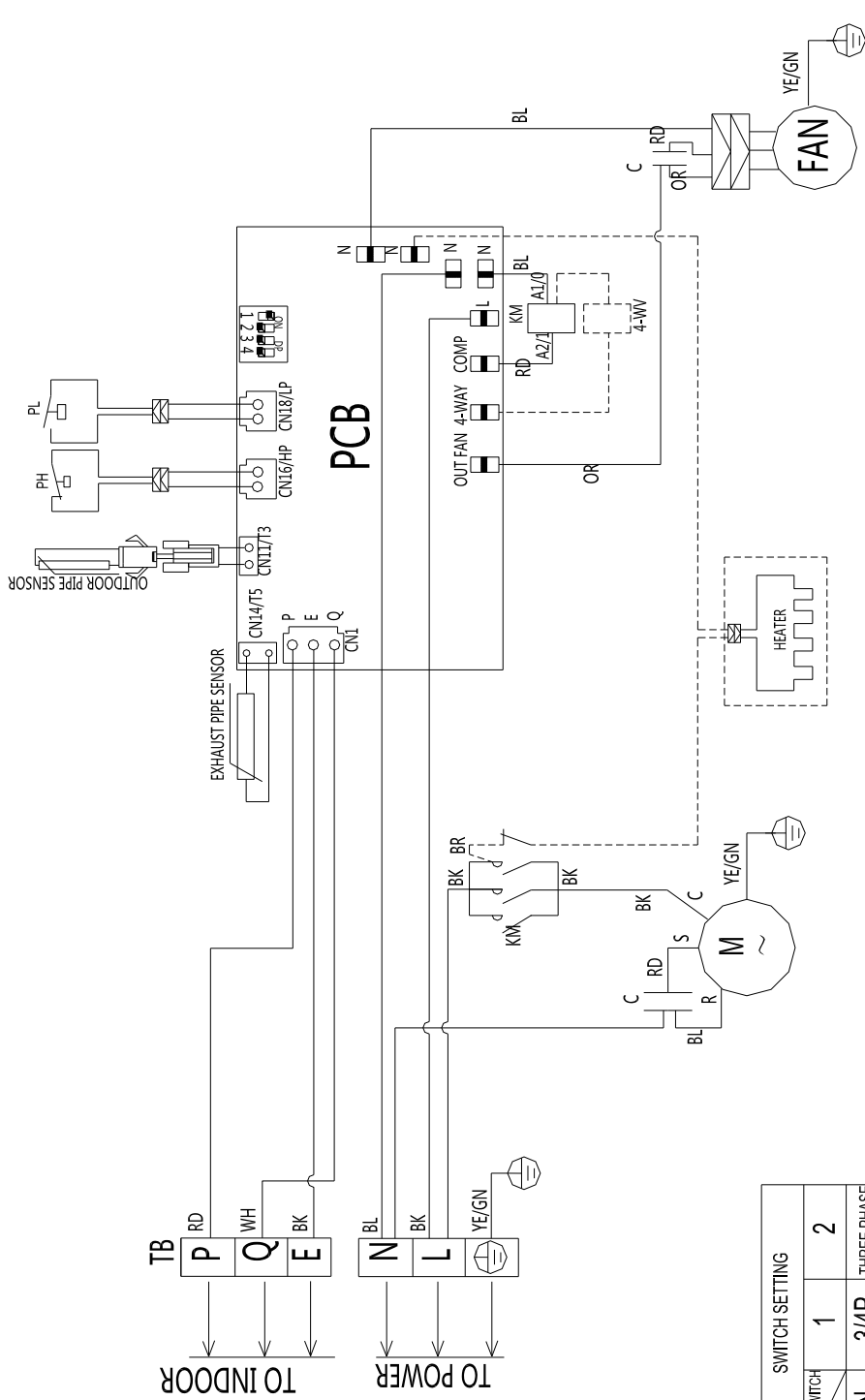

SWITCH SETTING	
SWITCH STATE	1 2
ON	3/4P THREE PHASE
OFF	5/6P SINGLE-PHASE

WIRE COLOR CODE	
RD RED	OR ORANGE
BK BLACK	GY GREY
BL BLUE	GN GREEN
PR PURPLE	BR BROWN
WIRE INFORMATION	
_____	FACTORY CONNECTION
_____	PROJECT CONNECTION
_____	PRACTICALITY EXTERIOR
_____	DASHED CIRCLE

NOTES

Showing the part chosen in the actual installation

1. The units should use unattached power switch, stated-cross-section wires and matching-spec. breaker.
2. Use the fuse within the specified scope, it can not replaced by iron wires or brass wires.
3. The units should install the stated-cross-section earth wire and keep it grounding unflinchingly.

COMPONENT CODE	
KM	CONTACTOR
C	CAPACITOR
M	COMPRESSOR
TB	TERMINAL-BLOCK
FM	FAN MOTOR
PL	LOW PRESSURE SWITCH
4-WV	4-WAY VALVE COIL
DATE	DWG.NO.
2015-06-21	SCHE036C3A/04/04/04
N.O.	
0	

### 4.4 SCHE036C7A (Power supply independently)

## CIRCUIT DIAGRAM

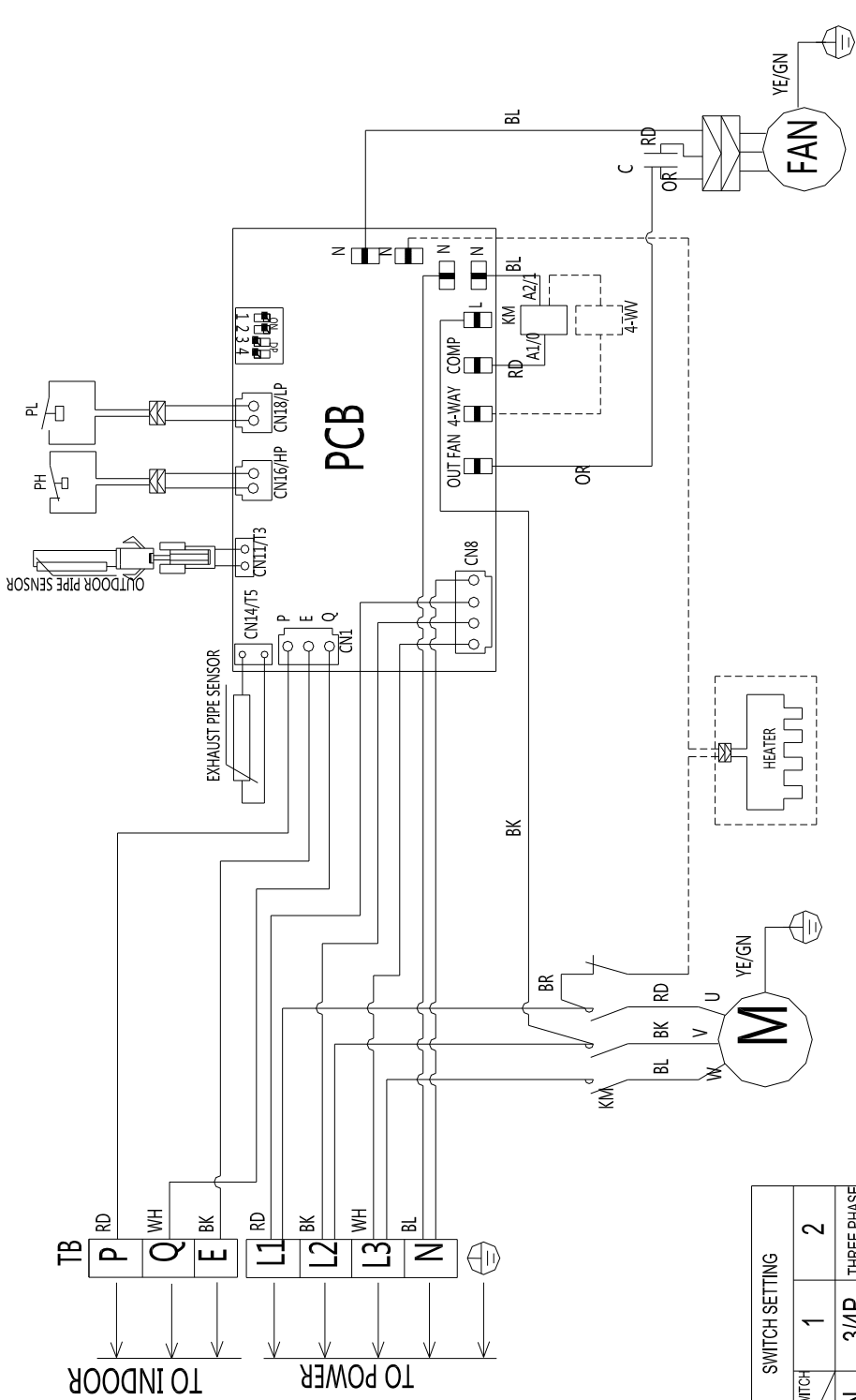

SWITCH SETTING	
SWITCH STATE	
ON	1 3/4P
OFF	2 5/6P
	THREE PHASE
	SINGLE-PHASE

WIRE COLOR CODE	
RD RED	WH WHITE
BK BLACK	GY GREY
BL BLUE	GN GREEN
PR PURPLE	BR BROWN
WIRE INFORMATION	
_____	FACTORY CONNECTION
_____	PROJECT CONNECTION
_____	PRACTICALITY EXTERIOR
_____	DASHED CIRCLE

--- Showing the part chosen in the actual installation

NOTES

1. The units should use unattached power switch, stated-cross-section wires and matching-spec. breaker.
2. Use the fuse within the specified scope, it can not replaced by iron wires or brass wires.
3. The units should install the stated-cross-section earth wire and keep it grounding unflinchingly.

COMPONENT CODE		
KM	CONTACTOR	
C	CAPACITOR	
M	COMPRESSOR	
TB	TERMINAL BLOCK	
FM	FAN MOTOR	
PL	LOW PRESSURE SWITCH	
4-WV	4-WAY VALVE COIL	
DATE	DWG.NO.	N.O.
2019/06/26	624679101000000000000000	0

### 4.5 SCHE048C7A , SCHE060C7A (Power supply independently)

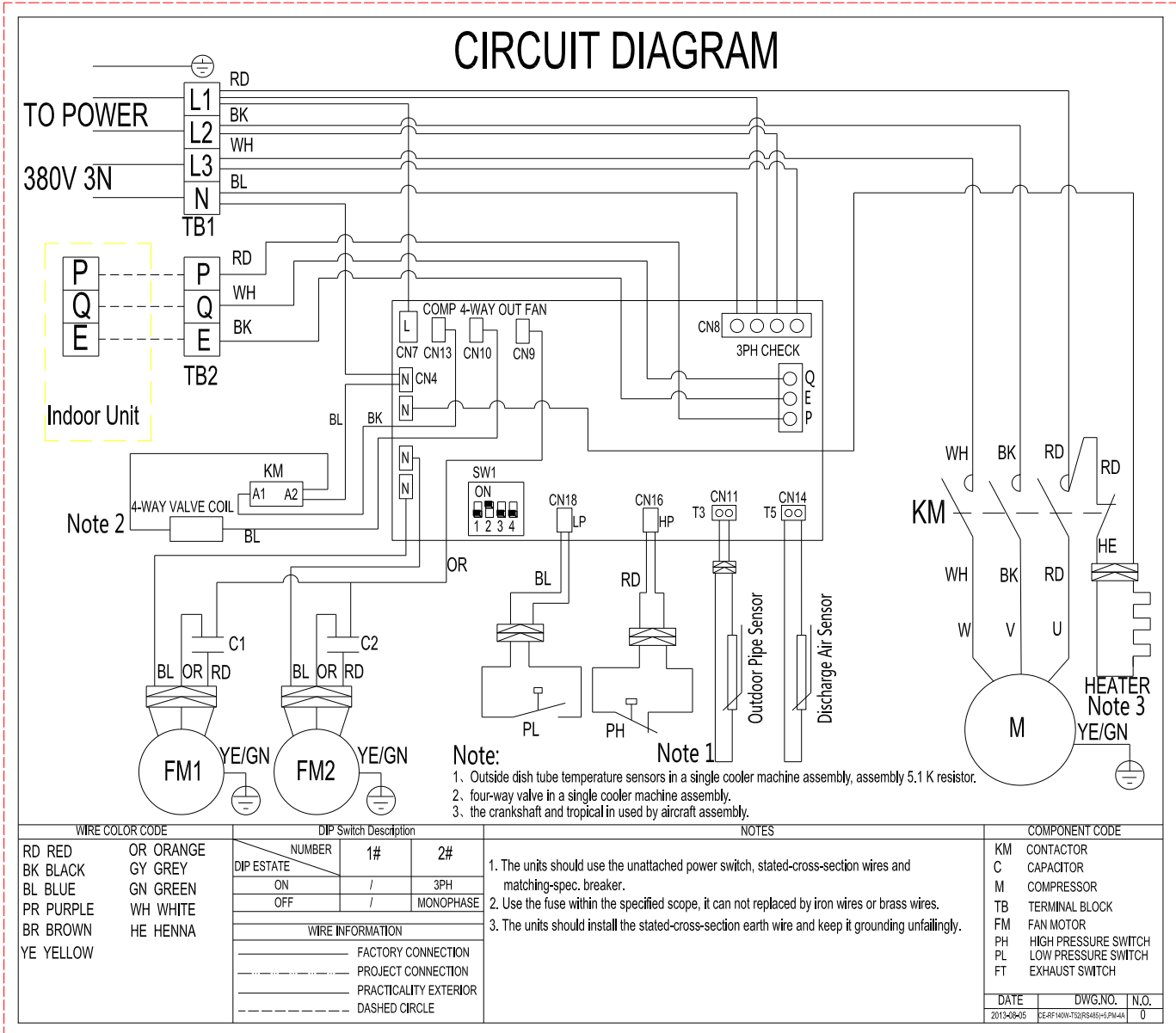

## 5. Electric Characteristics

Model	Outdoor Unit				
	Hz	254	Min.	Max.	Outdoor motor (kw)
SCHE012C3A	50	254	198	254	0.07
SCHE018C3A	50	254	198	254	0.08
SCHE024C3A	50	254	198	254	0.15
SCHE036C3A	50	418V	198	254	0.45
SCHE036C7A	50	418V	342V	418V	0.45
SCHE048C7A	50	418V	342V	418V	0.34
SCHE060C7A	50	380~415V	342V	418V	0.34



## 6.Operation Limits

<b>Operation Mode</b>	<b>Outdoor temperature(°C)</b>	<b>Room temperature(°C)</b>
Cooling operation	18~43	16~32
Heating operation	-7~24	16~32

## 7.Sound Levels

### Outdoor Unit

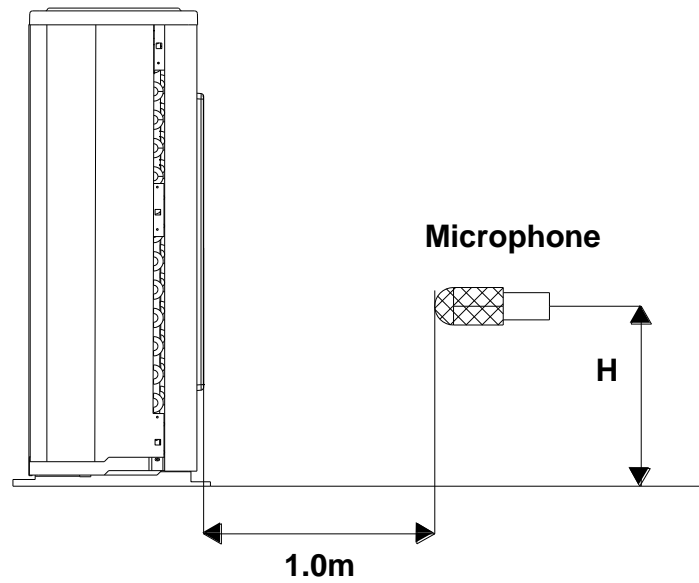

**Note:**  $H = 0.5 \times (\text{height of outdoor unit} +)$

Model	Noise level dB(A)
SCHE012C3A	55
SCHE018C3A	53
SCHE024C3A	58
SCHE036C3A	65
SCHE036C7A	65
SCHE048C7A	60
SCHE060C7A	60

## 8.Exploded View

### 8.1 SCHE012C3A, SCHE018C3A

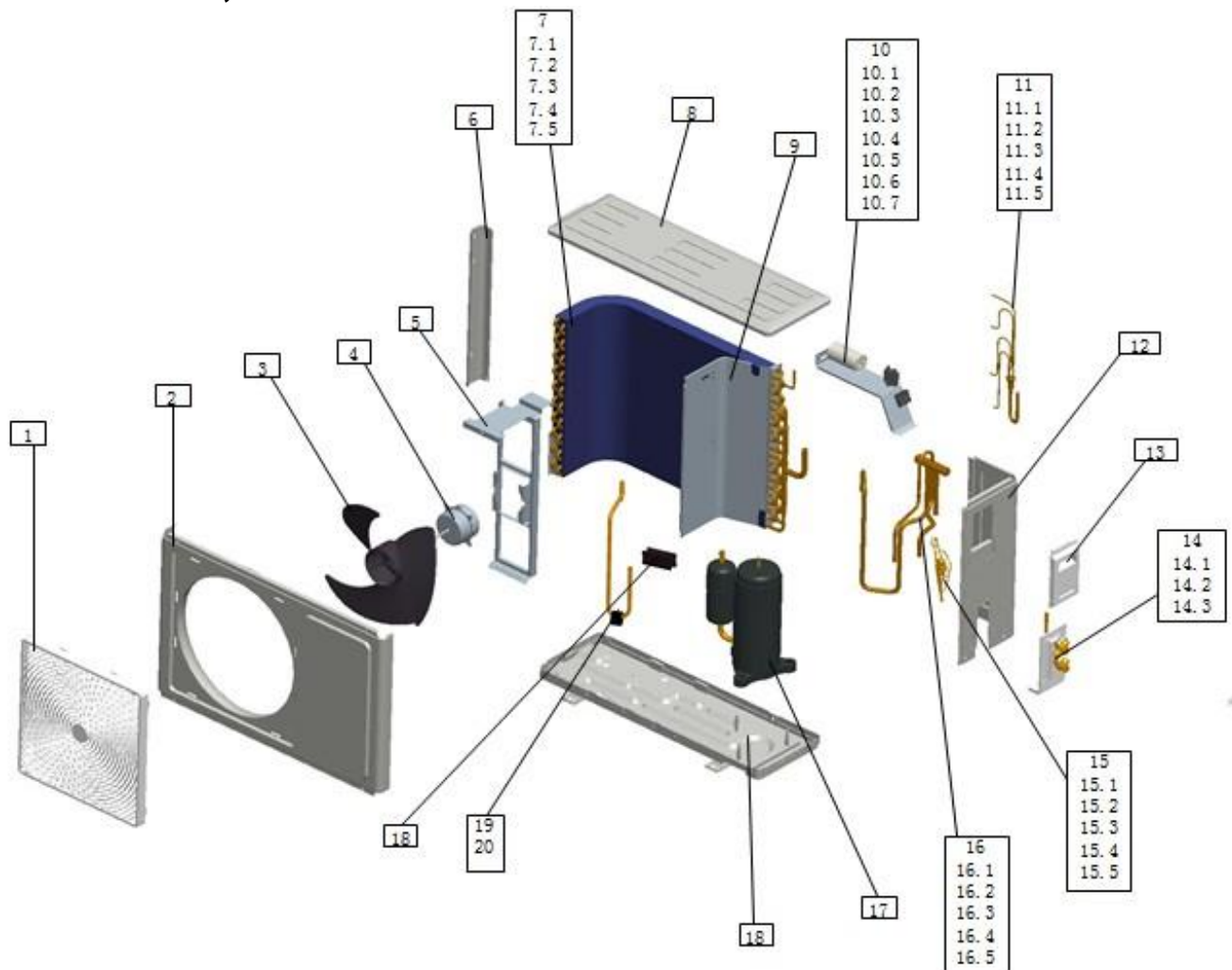

No.	Part Name	Quantity	No.	Part Name	Quantity
1	Top net	1	11	Pre-welding assy for distributing capillary	1
2	Panel assy	1	12	Right clapboard	1
3	Propeller fan	1	13	Handle	1
4	Fan motor	1	14	Valve holder assy	1
5	Holder for fan motor	1	15	Pre-welding assy for throttle capillary	1
6	column	1	16	4-Ways valve assy	1
7	Condenser assy	1	17	Compressor	1
8	Cover	1	18	Chassis	1
9	Separating board	1	19	shock absorber block ( ball )	1
10	E-parts assy	1	20	shock absorber block	1

## 8.2 SCHE024C3A

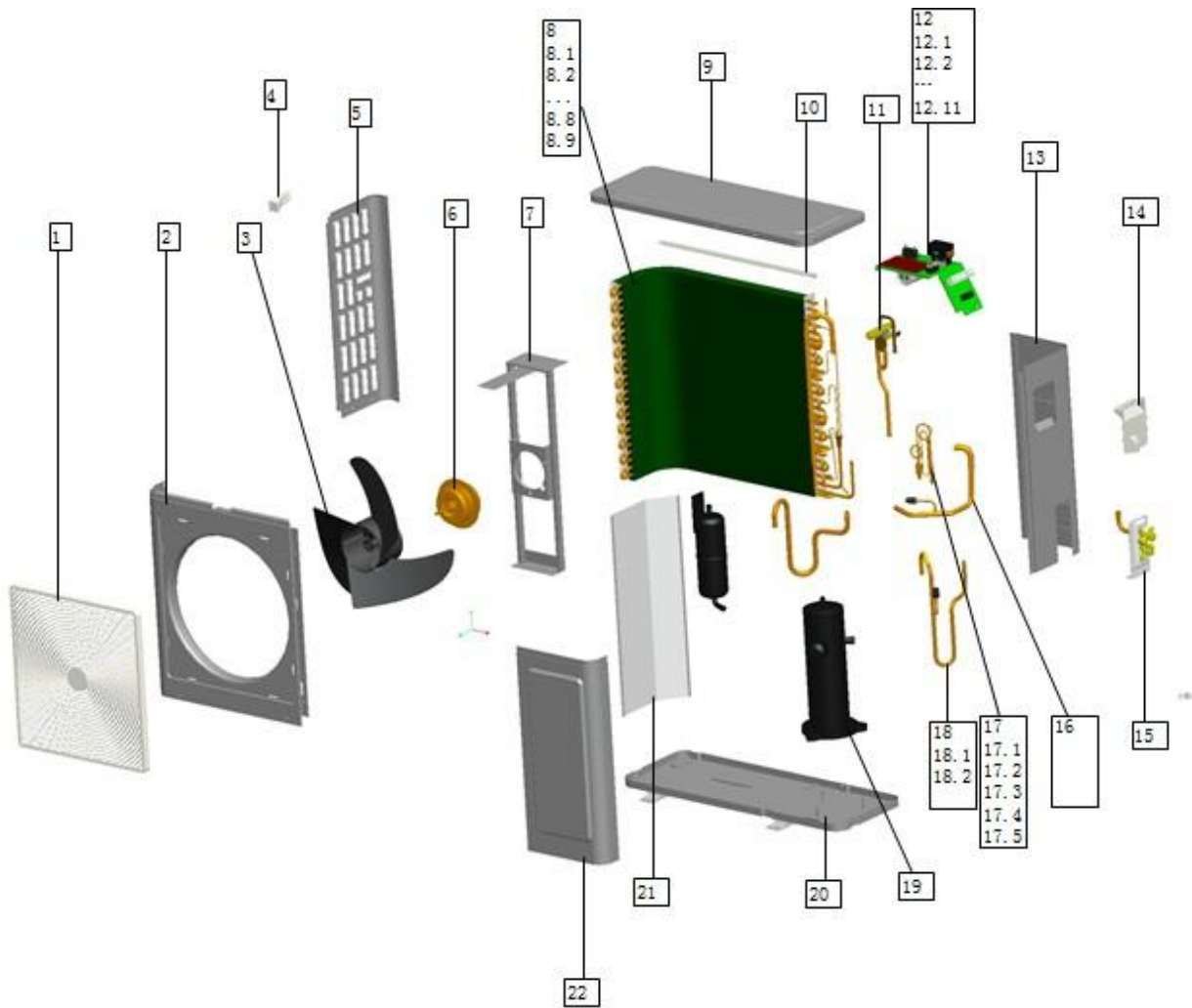

No.	Part Name	Quantity	No.	Part Name	Quantity
1	Front top net	1	12.10	Control wire for 4-Ways valve	1
2	Front panel	1	12.11	Contactor	1
3	Propeller fan	1	13	Right clapboard	1
4	Handle	1	14	Handle	1
5	Left clapboard	1	15.1	Valve holder	1
6	Fan motor	1	15.2	Cut-off valve DN8	1
7	Holder for fan motor	1	15.3	Cut-off valve DN13	1
8	Condenser assy	1	16	Suction pipe	1
9	Cover	1	17	Pre-welding assy for throttle capillary	1
10	Back connection	1	18	Discharge pipe assy	1
11	4-Ways valve assy	1	19	Compressor	1
11.1	4-Ways valve	1	20	Chassis	1
11.2	Return pipe of compressor	1	21	Separating board	1
11.3	Low pressure valve connecting pipe	1	22	Maintenance panel	1
12	E-parts assy	1			

### 8.3 SCHE036C3A ,SCHE036C7A

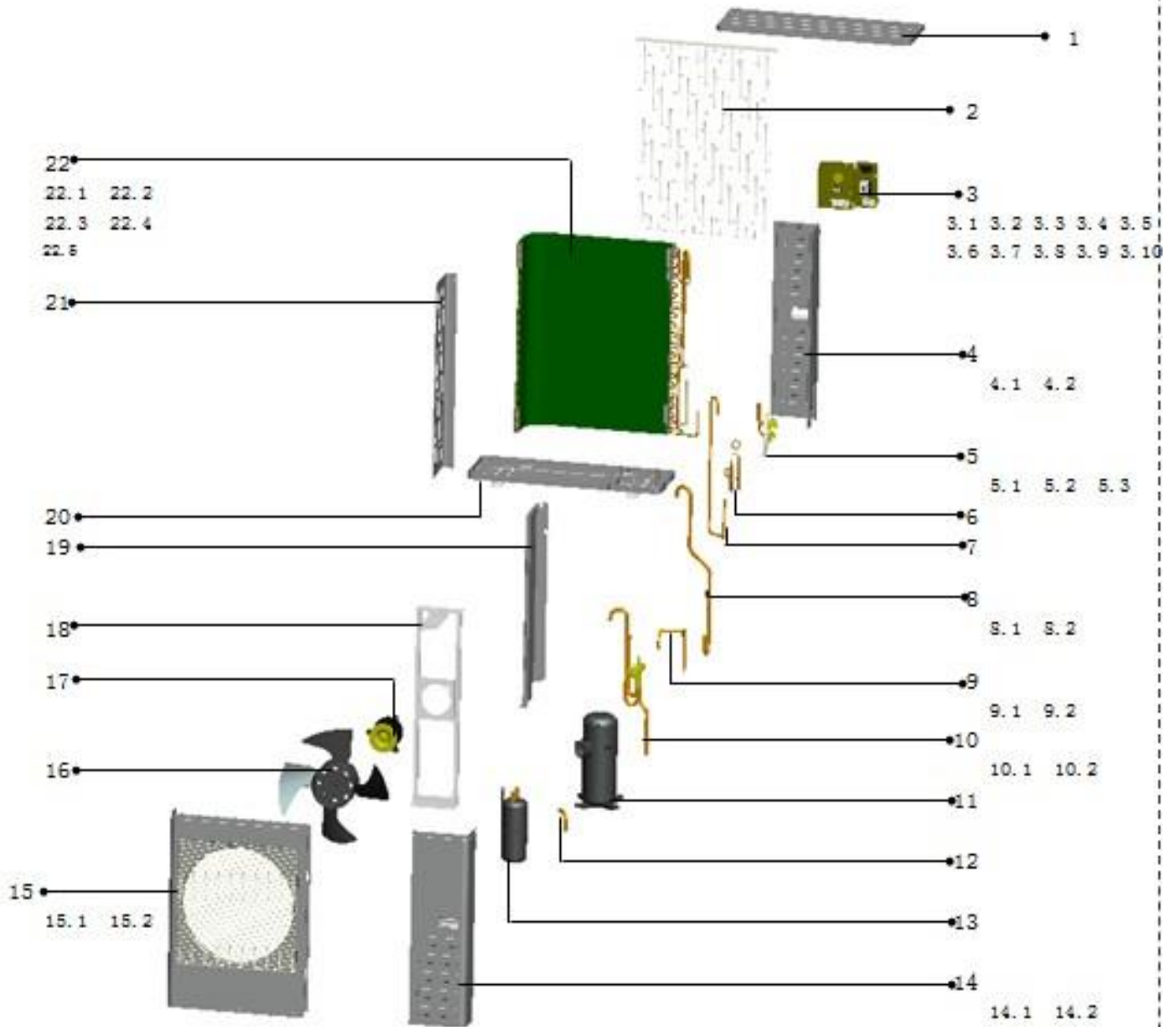

No.	Part Name	Quantity	No.	Part Name	Quantity
1	Cover	1	9.1	Discharge pipe A for compressor	1
2	Rear net	1	9.2	High-pressure switch	1
3	E-parts assy	1	10	4-Ways valve assy	1
3.1	Fan motor capacitor	1	10.1	4-Ways valve assy	1
3.2	temp. sensor	1	10.2	Control wire for 4-Ways valve	1
3.3	Contactora	1	11	Compressor	1
3.4	Terminal	1	12	Suction pipe for compressor	1
3.5	Terminal	1	13	Vapor-liquid separator	1
3.6	Cover for E-parts	1	14	Maintenance board assy	1
3.7	Main control board	1	14.1	Maintenance board	1
3.8	Protection cap	2	14.2	Handle	1
3.9	Discharge temp sensor	1	15	Front panel assy	1
3.10	Groove clamp 4	1	15.1	Panel	1
4	Right clapboard assy	1	15.2	Top net	1
4.1	Right clapboard	1	16	Propeller fan	1
4.2	handle	1	17	Fan motor	1
5	Valve holder assy	1	18	Holder for fan motor	1
5.1	Valve holder	1	19	Separating board	1
5.2	Cut-off valve	1	20	Chassis	1
5.3	Cut-off valve DN16	1	21	Left clapboard	1
6	Pre-welding assy for throttle capillary	1	22	Condenser assy	1
7	Discharge pipe B for compressor	1	22.1	Condenser	1
8	Pre-welding assy for compressor suction pipe B	1	22.2	Pre-welding assy for condenser collecting pipe	1
8.1	Suction pipe B for compressor	1	22.3	Pre-welding assy for distributing capillary	1
8.2	Low-pressure switch	1	22.4	Condenser inlet tube shockproof tubule	1
9	Pre-welding assy for discharge pipe A	1	22.5	Cold out pipe	1

### 8.4 SCHE048C3A , SCHE060C3A

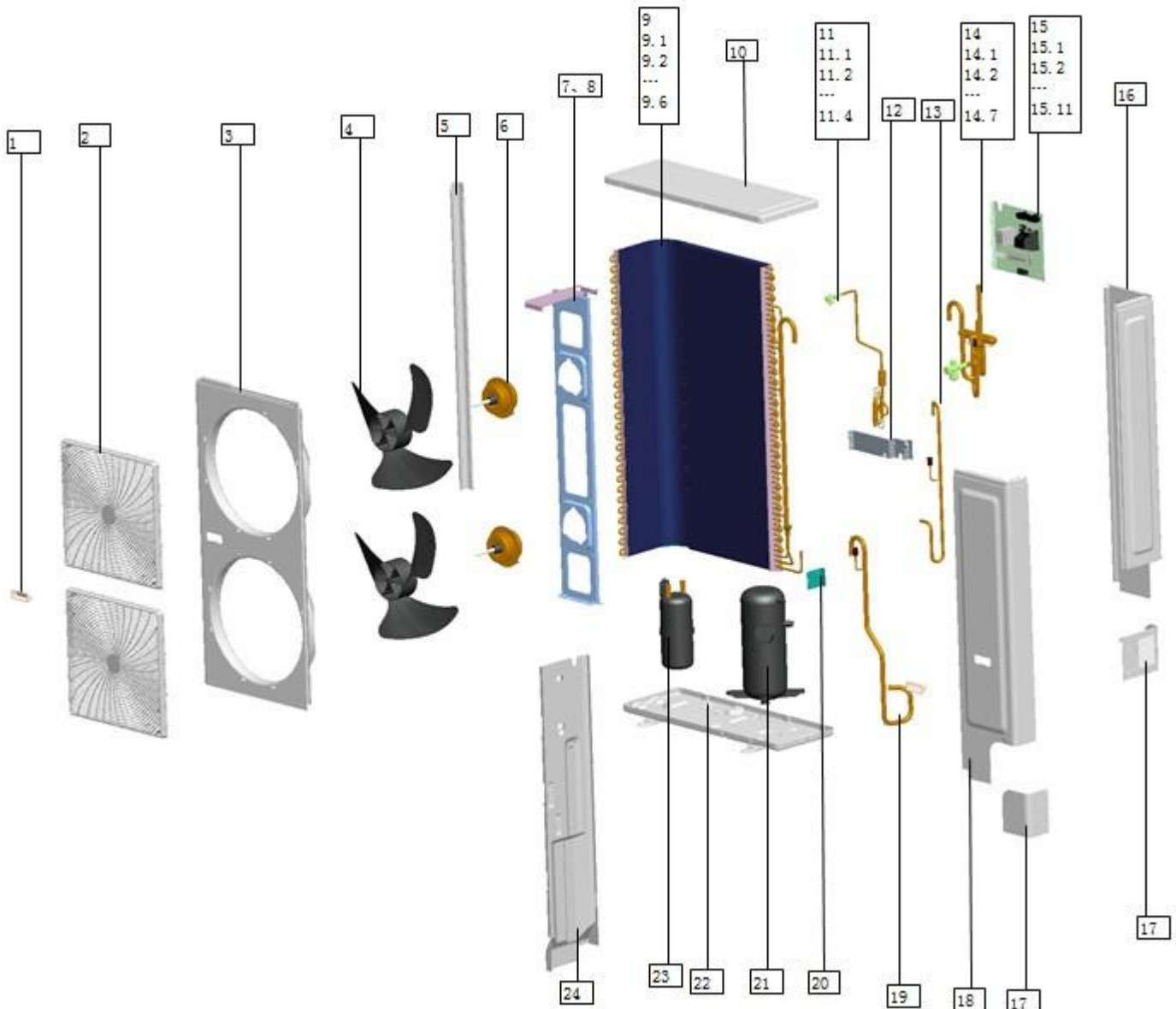

No.	Part Name	Quantity	No.	Part Name	Quantity
1	Handle	3	14.3	Cut-off valve DN16	1
2	Top net	2	14.4	4-Ways valve connecting pipe	1
3	Front panel	1	14.5	4-Ways valve connecting pipe	1
4	Propeller fan	2	14.6	4-Ways valve connecting pipe	1
5	Column	1	14.7	Control wire for 4-Ways valve	1
6	Fan motor	2	15	E-parts assy	1
7	Holder for fan motor	1	15.1	Temp sensor	1
8	Motor bracket connecting plate	1	15.2	Electric control board assy	1
9	Condenser assy	1	15.3	Terminal	1
9.1	Condenser	1	15.4	Terminal	1
9.2	Collector components	1	15.5	Groove clamp 3	1
9.3	Cold out pipe	1	15.6	Groove clamp 9	1
9.4	Condenser inlet tube shockproof tubule	1	15.7	Exhaust temp sensor	1
9.5	Probe of copper pipe	1	15.8	Electronic control mounting plate	1
9.6	Distributing capillary assy	1	15.9	Protection cap	1
10	Cover	1	15.10	Fan motor capacitor	2
11	High pressure valve connecting pipe assy	1	15.11	Contactora	1
11.1	filter	1	16	Rear panel	1
11.2	Refrigeration capillary	1	17	Rear side valve board	1
11.3	High pressure valve connecting pipe	1	18	Right clapboard	1
11.4	Cut-off valve DN8	1	19	Suction pipe assy	1
12	Valve holder	1	19.1	Suction pipe	1
13	Discharge pipe assy	1	19.2	Low-pressure switch	1
13.1	Discharge pipe	1	20	Machine foot cover	1
13.2	Probe of copper pipe	1	21	Compressor assy	1
13.3	High-pressure switch	1	22	Chassis	1
13.4	Probe of copper pipe	1	23	Vapor-liquid separator	1
14	4-Ways valve assy	1	24	Separating board	1
14.1	4-Ways valve	1			
14.2	Process pipe	1			



## 9.Troubleshooting

### Fault display

<b>Faults</b>	<b>LED</b>
High pressure failure	Green light flashes once every 5s
Low pressure failure	Green light flashes 2 times every 5s
Temperature sensor T3 failure	Green light flashes 3 times every 5s
Overflow test failure	Green light flashes 4 times every 5s
Phase sequence test failure	Green light flashes 5 times every 5s
Exhaust temperature over-high failure	Green light flashes 6 times every 5s
Normal communication receiving	Yellow light keeps constant on
No communication receiving	Yellow light extinguishes
Communication failure warning	Yellow light flashes

## Part 4 Installation

1.Precaution on Installation .....	126
2.Vacuum Dry and Leakage Checking .....	127
3.Additional Refrigerant Charge .....	129
4.Water Drainage .....	130
5.Insulation Work .....	133
6.Test Operation.....	135

## 1. Precaution on Installation

1.1. Measure the necessary length of the connecting pipe, and make it by the following way.

a. Connect the indoor unit at first, then the outdoor unit.

Bend the tubing in proper way. Do not harm them.

### CAUTIONS:

- Daub the surfaces of the flare pipe and the joint nuts with frozen oil, and wrench it for 3~4 rounds

- With hands before fasten the flare nuts.

Be sure to use two wrenches simultaneously when you connect or disconnect the pipes.

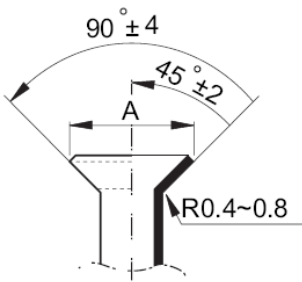
Pipe gauge	Tightening torque	Flare dimension A		Flare shape
		Min (mm)	Max	
Φ6.4	15~16N.m (153~163 kgf.cm)	8.3	8.7	
Φ9.5	25~26N.m (255~265kgf.cm)	12.0	12.4	
Φ12.7	35~36N.m (357~367kgf.cm)	15.4	15.8	
Φ15.9	45~47N.m (459~480 kgf.cm)	18.6	19.1	
Φ19.1	65~67N.m (663~684kgf.cm)	22.9	23.3	

b. The stop value of the outdoor unit should be closed absolutely (as original state). Every time you connect it, first loosen the nuts at the part of stop value, then connect the flare pipe immediately (in 5 minutes). If the nuts have been loosened for a long time, dusts and other impurities may enter the pipe system and may cause malfunction later. So please expel the air out of the pipe with refrigerant before connection.

c. Expel the air after connecting the refrigerant pipe with the indoor unit and the outdoor unit. Then fasten the nuts at the repair-points.

### 1.2. Locate The Pipe

a. Drill a hole in the wall (suitable just for the size of the wall conduit), then set on the fittings such as the wall conduit and its cover.

b. Bind the connecting pipe and the cables together tightly with binding tapes. Do not let air in, which will cause water leakage by condensation.

c. Pass the bound connecting pipe through the wall conduit from outside. Be careful of the pipe allocation to do no damage to the tubing.

### 1.3. Connect the pipes.

1.4. Then, open the stem of stop values of the outdoor unit to make the refrigerant pipe connecting the indoor unit with the outdoor unit in fluent flow.

1.5. Be sure of no leakage by checking it with leak detector or soap water.

1.6. Cover the joint of the connecting pipe to the indoor unit with the soundproof / insulating sheath (fittings), and bind it well with the tapes to prevent leakage.

## 2. Vacuum Dry and Leakage Checking

2.1 Vacuum Dry: use vacuum pump to change the moisture (liquid) into steam (gas) in the pipe and discharge it out of the pipe to make the pipe dry. Under one atmospheric pressure, the boiling point of water (steam temperature) is 100°C. Use vacuum pump to make the pressure in the pipe near vacuum state, the boiling point of water falls relatively. When it falls under outdoor temperature, the moisture in the pipe will be vaporized.

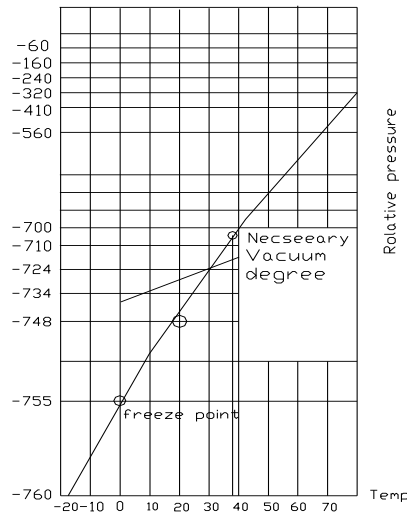

### 2.2 Vacuum dry procedure

There are two methods of vacuum dry due to different construction environment: common vacuum dry, special vacuum dry.

#### ①. Common vacuum dry procedure

- Vacuum dry (for the first time)---connect the all-purpose detector to the inlet of liquid pipe and gas pipe, and run the vacuum pump more than two hours (the vacuum pump should be below -755mmHg)
- If the pump can't achieve below -755mmHg after pumping 2 hours, moisture or leakage point will still exist in the pipe. At this time, it should be pumped 1 hour more.
- If the pump can't achieve -755mmHg after pumping 3 hours, please check if there are some leakage points.
- Vacuum placement test: place 1 hour when it achieves -755mmHg, pass if the vacuum watch shows no rising. If it rises, it shows there's moisture or leakage point.
- Vacuuming from liquid pipe and gas pipe at the same time.
- Sketch map of common vacuum dry procedure.

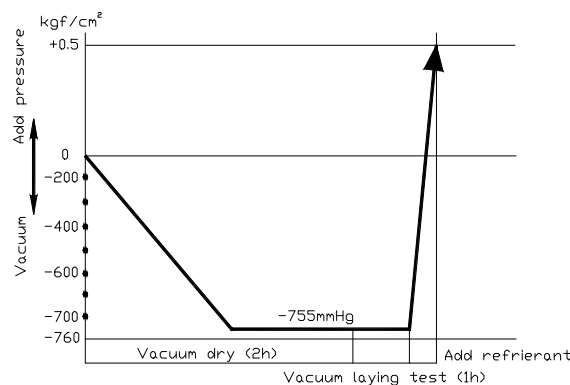

②. Special vacuum dry procedure

- This vacuum dry method is used in the following conditions:
- There's moisture when flushing the refrigerant pipe.
- Rainwater may enter into the pipe.
- Vacuum dry for the first time ..... 2h pumping

③. Vacuum destroy for the second time ..... Fill nitrogen to 0.5Kgf/cm<sup>2</sup>

Because nitrogen is for drying gas, it has vacuum drying effect during vacuum destroy. But if the moisture is too much, this method can't dry thoroughly. So, please pay more attention to prevent water entering and forming condensation water.

④. Vacuum dry for the second time.....1h pumping

Determinant: Pass if achieving below -755mmHg. If -755mmHg can't be achieved in 2h, repeat procedure ③ and ④.

⑤. Vacuum placing test ..... 1h

⑥. Sketch map of special vacuum dry procedure

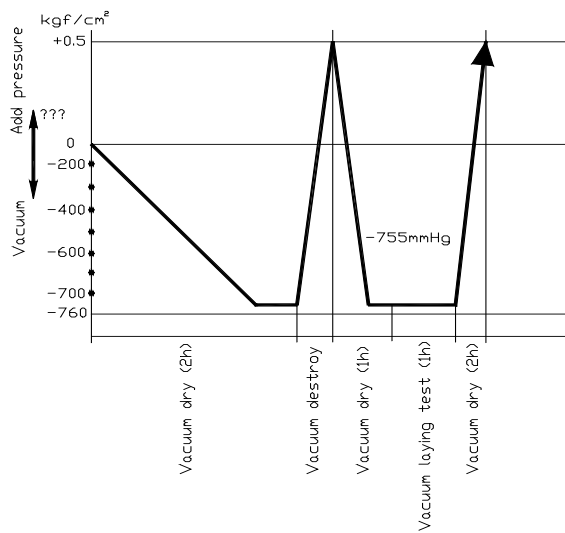

### 3.Additional Refrigerant Charge

#### Caution

- Refrigerant cannot be charged until field wiring has been completed.
- Refrigerant may only be charged after performing the leak test and the vacuum pumping.
- When charging a system, care shall be taken that its maximum permissible charge is never exceeded, in view of the danger of liquid hammer.
- Charging with an unsuitable substance may cause explosions and accidents, so always ensure that the appropriate refrigerant is charged.
- Refrigerant containers shall be opened slowly.
- Always use protective gloves and protect your eyes when charging refrigerant.

The outdoor unit is factory charged with refrigerant. Calculate the added refrigerant according to the diameter and the length of the liquid side pipe of the outdoor unit/indoor unit

R(g) \ D(mm)	φ6.4	φ9.5	φ12.7
L(m)			
Less than 5m (One-way)	—	—	—
Added Refrigerant When Over 5m(One-way)	30g/m×(L-5)	65g/m×(L-5)	120g/m×(L-5)

#### Remark:

R (g): Additional refrigerant to be charged

L (m): The length of the refrigerant pipe (one-way)

D (mm): Liquid side piping

## 4. Water Drainage

### 4.1 Gradient and Supporting

4.1.1 Keep the drainpipe sloping downwards at a gradient of at least 1/100. Keep the drainpipe as short as possible and eliminate the air bubble.

4.1.2 The horizontal drainpipe should be short. When the pipe is too long, a prop stand must be installed to keep the gradient of 1/100 and prevent bending. Refer to the following table for the specification of the prop stand.

	Diameter	Distance between the prop stands
Hard PVC pipe	25~40mm	1~1.5m

#### 4.1.3. Precautions

- ① The diameter of drainpipe should meet the drainage requirement at least.
- ② The drainpipe should be heat-insulated to prevent atomization.
- ③ Drainpipe should be installed before installing indoor unit. After powering on, there is some water in water-receiver plate. Please check if the drain pump can operate correctly.
- ④ All connection should be firm.
- ⑤ Wipe color on PVC pipe to note connection.
- ⑥ Climbing, horizontal and bending conditions are prohibited.
- ⑦ The dimension of drainpipe can't less than the connecting dimension of indoor drainpipe.
- ⑧ Heat-insulation should be done well to prevent condensation.
- ⑨ Indoor units with different drainage type can't share one convergent drainpipe.

### 4.2 Drainpipe Trap

4.2.1. If the pressure at the connection of the drainpipe is negative, it needs to design drainpipe trap.

4.2.2. Every indoor unit needs one drainpipe trap.

4.2.3. A plug should be designed to do cleaning.

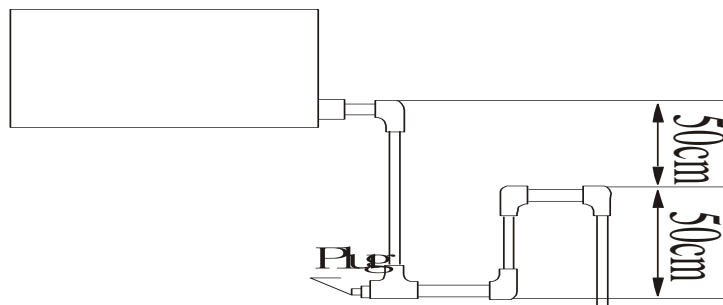

### 4.3 Upwards drainage (drain pump)

#### For Four-way cassette(compact)

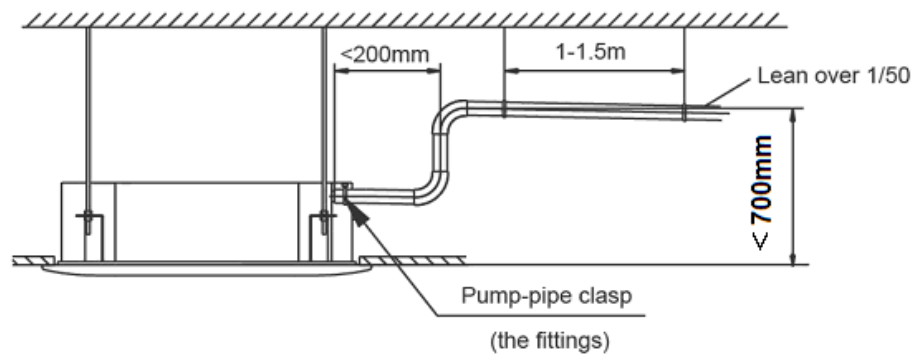

#### For Four-way cassette

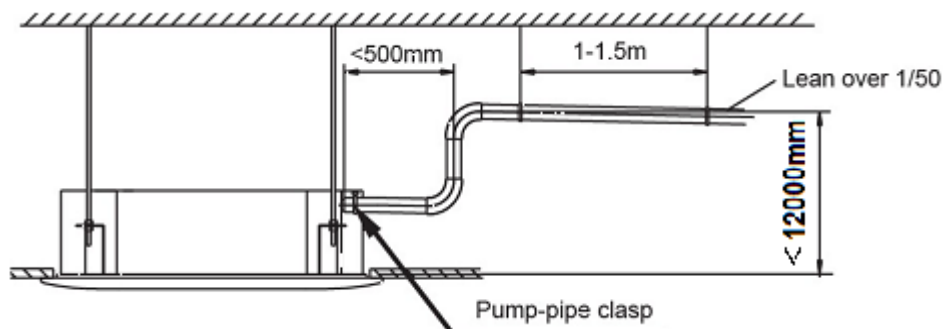

### 4.4 Convergent drainage

4.4.1. The number of indoor units should be as small as possible to prevent the traverse main pipe overlong.

4.4.2. Indoor unit with drain pump and indoor unit without drain pump should be in different drainage system.

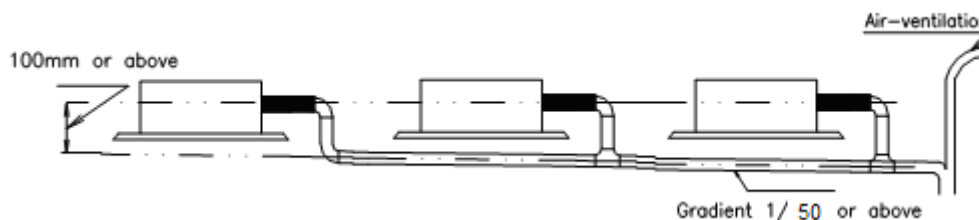

#### 4.4.3. Selecting the diameter

Number of connecting indoor units → Calculate drainage volume → Select the diameter  
 Calculate allowed volume = Total cooling capacity of indoor units(HP)×2 (l/ hr)

	Allowed volume(lean 1/50) (l/ hr)	I.D. (mm)	Thick
Hard PVC	$\sim \leq 14$	$\phi 25$	3.0
Hard PVC	$14 < \sim \leq 88$	$\phi 30$	3.5
Hard PVC	$88 < \sim \leq 334$	$\phi 40$	4.0
Hard PVC	$175 < \sim \leq 334$	$\phi 50$	4.5
Hard PVC	$334 < \sim$	$\phi 80$	6.0



## 4.5 Drainage test

### 4.5.1 Drainage without drain pump

After finishing drainpipe installation, pour some water into the water receiver plate to check if the water flows smoothly.

### 4.5.2 Drainage with drain pump

- ① Poke the Water Level Switch, remove the cover, use water pipe to pour 2000ml water into the water receipt plate through the water inlet.

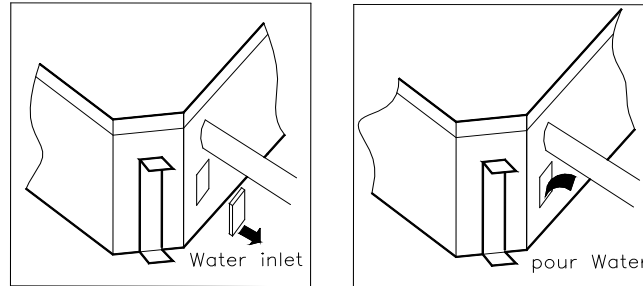

- ② Turn on the power to Cooling operation. Check the pump's operation and switch on the Water Level Switch. Check the pump's sound and look into the transparent hard pipe in the outlet at the same time to check if the water can discharge normally.

- ③ Stop the air conditioner running, turn off the power, and put back the cover.

- Stop the air conditioner. After 3 minutes, check if it has abnormality. If the collocation of drainpipes is illogical, the water will flow back overfull, which will cause the alarm lamp flashes, even overflow from the water receipt plate.
- Keep on pouring water until it gives an alarm signal for high water level, check if the pump drains water at once. If the water level can't fall below the alarmed water level after 3 minutes, the air conditioner will stop. Turn off the power and drain the remained water, and then turn on the air conditioner.

Note: the drain stuff in the main water receipt plate is for maintenance. Stuff up the drain stuff to prevent water leakage.

## 5. Insulation Work

### 5.1 Insulation material and thickness

#### 5.1.1. Insulation material

Insulation material should adopt the material which is able to endure the pipe's temperature: no less than 70°C in the high-pressure side, no less than 120°C in the low-pressure side (For the cooling type machine, no requirements at the low-pressure side.)

- ◆ Example: Heat pump type----Heat-resistant Polyethylene foam (withstand above 120°C)  
Cooling only type----Polyethylene foam (withstand above 100°C)

#### 5.1.2. Thickness choice for insulation material

Insulation material thickness is as follows:

	Pipe diameter (mm)	Adiabatic material thickness
Refrigerant pipe	Φ6.4—Φ25.4	10mm
	Φ28.6—Φ38.1	15mm
Drainage pipe	Inner diameter Φ20—Φ32	6mm

### 5.2 Refrigerant pipe insulation

#### 5.2.1. Work Procedure

- ① Before laying the pipes, the non-jointing parts and non-connection parts should be heat insulated.
- ② When the gas proof test is eligible, the jointing area, expanding area and the flange area should be heat insulated

#### 5.2.2. Insulation for non-jointing parts and non-connection parts

wrong	right	
Gas pipe and liquid pipe should not be put together to insulate	Insulate the gas pipe (cooling only)	Insulate the gas pipe and liquid pipe

For construction convenience, before laying pipes, use insulation material to insulate the pipes to be deal with, at the same time, at two ends of the pipe, remain some length not to be insulated, in order to be welded and check the leakage after laying the pipes.

### 5.2.3. Insulate for the jointing area, expanding area and the flange area

- ① Insulate for the jointing area, expanding area and the flange area should be done after checking leakage of the pipes
- ② Make sure there's no clearance in the joining part of the accessorial insulation material and local preparative insulation material.

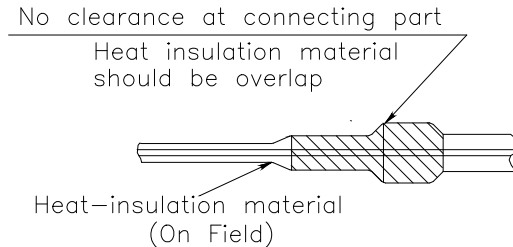

### 5.3 Drainage pipe insulation

The connection part should be insulated, or else water will be condensing at the non-insulation part.

#### 5.4 Note

5.4.1 The jointing area, expanding area and the flange area should be heat insulated after passing the pressure test

5.4.2 The gas and liquid pipe should be heat insulated individually, the connecting part should be heat insulated individually.

5.4.3 Use the attached heat-insulation material to insulate the pipe connections (pipes' tie-in ,expand nut ) of the indoor unit

## 6. Test Operation

- (1) The test operation must be carried out after the entire installation has been completed.
- (2) Please confirm the following points before the test operation.
  - The indoor unit and outdoor unit are installed properly.
  - Tubing and wiring are correctly completed.
  - The refrigerant pipe system is leakage-checked.
  - The drainage is unimpeded.
  - The ground wiring is connected correctly.
  - The length of the tubing and the added stow capacity of the refrigerant have been recorded.
  - The power voltage fits the rated voltage of the air conditioner.
  - There is no obstacle at the outlet and inlet of the outdoor and indoor units.
  - The gas-side and liquid-side stop valves are both opened.
  - The air conditioner is pre-heated by turning on the power.
- (3) According to the user's requirement, install the remote controller when the remote controller's signal can reach the indoor unit smoothly.

### (4) Test operation

Set the air conditioner under the mode of "COOLING" with the remote controller, and check the following points.

#### Indoor unit

- Whether the switch on the remote controller works well.
- Whether the buttons on the remote controller works well.
- Whether the air flow louver moves normally.
- Whether the room temperature is adjusted well.
- Whether the indicator lights normally.
- Whether the temporary buttons works well.
- Whether the drainage is normal.
- Whether there is vibration or abnormal noise during operation.

#### Outdoor unit

- Whether there is vibration or abnormal noise during operation.
- Whether the generated wind, noise, or condensed of by the air conditioner have influenced your neighborhood.
- Whether any of the refrigerant is leaked.

## Part 5 Control

1.Wireless Remote Controller .....	137
2.Wired Controller .....	140

# 1. Wireless Remote Controller

## 1.1 Jingling VAEWP-G001

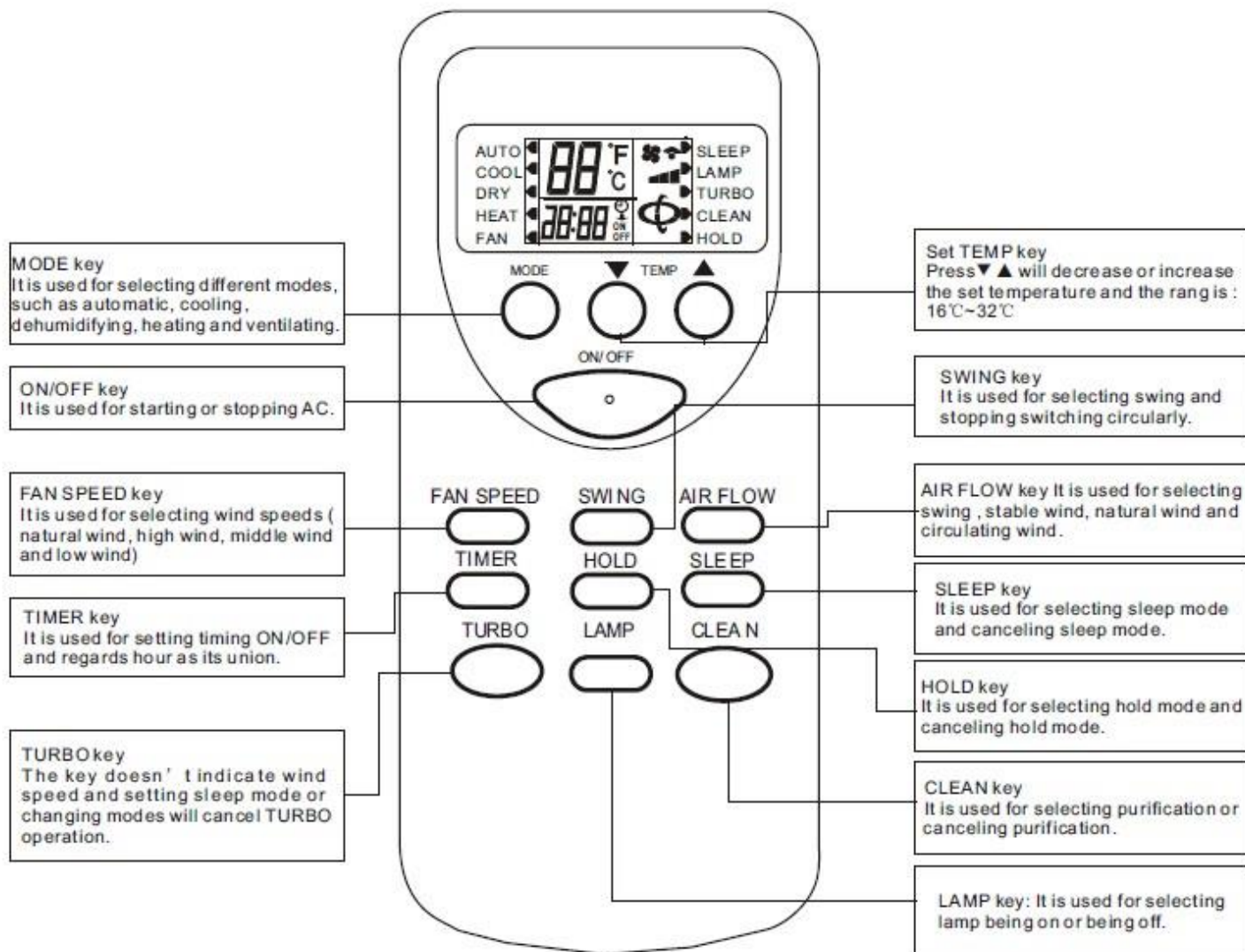

### USE OF REMOTE CONTROLLER

The controller below is the Jingling Common Remote Controller, SWING key, TURBO key, LAMP key and CLEAN key is applicable for special latest developed new models instead of normal ones.

### FUNCTION KEY

#### A. ON/OFF key:

Press the key and the remote control will switch circularly in the order: ON→OFF→ON. When it is powered on at first from off state to on state, the default setting of work condition is ( The set temperature is 25°C and the mode , wind speed, swing and air door are all automatic and there

is no lamp, no turbo, no purification, no sleep, no timing and no hold function ). When it is not powered on firstly from off state to on state, the work condition is as the same as the state before stopping. It will cancel damp, purification, sleep, turbo and timing running mode.

B. MODE key:

Press the key to switch modes in the order: automatic cooling →dehumidify →heating →ventilating →automatic.

C. " ▼ " key:

In dehumidifying mode and automatic mode, pressing the key cannot change the temperature. In other mode, press the key once and the temperature will decrease 1°C in the order: 32°C→31°C →...→17°C→16°C .

D. " ▲ " key:

In dehumidifying mode and automatic mode, pressing the key cannot change the temperature. In other mode, press the key once and the temperature will increase 1°C in the order: 16°C→17°C →...→31°C→32°C.

E. SWING key:

In dehumidifying mode, the swing mode is in the stable wind mode without change. In other mode, press the key to switch modes in the order: swing → stable wind→ natural wind →swing

F. AIR FLOW key:

The default air flow is in the swing mode when starting firstly and press the key to switch modes in the order: swing →stop →swing.

G. WIND SPEED key:

The default wind speed is in the automatic wind mode when starting firstly. The remote control won't react by pressing the key because the wind speed can't be adjusted and in low speed in dehumidifying mode. In other mode, press the key to switch modes in the order:

Automatic wind→ high speed →middle speed→ low speed →automatic wind

H. TIMER key:

The default mode is in no timing state, press the key to set timing time with hour as its union. The switch order is: 1H→2H→...→24H→cancel→1H.... Press the key to set timing starting in the off state and set timing stopping in the on state. After setting timing function, the time keeps decreasing per hour until the time decreasing to the timing on or timing off and the timing display will be cancelled at the same time. Pressing MODE key can't cancel timing in timing mode

which will send out the order of timing time by pressing other key.

I. TURBO key:

The default state for the control is no turbo and the key don't work in the automatic mode, dehumidifying mode and ventilating mode (It will not display any contents and not send out any codes). The control, however, will switch between on and off by pressing the key in other mode. The wind speed isn't indicated in turbo mode and it will be cancelled for changing modes and setting sleep mode.

J. SLEEP key:

Press the key to switch modes in the order: sleep→ cancel sleep→ sleep. The sleep function won't be cancelled for changing modes. Press the key to set sleep mode and the wind speed will automatically be switched to low speed and it can adjust the wind speed by pressing the WIND SPEED key (except dehumidifying mode).

K. LOCK key:

The default state is in no LOCK key state, press the key to select modes in order: LOCK key →cancel LOCK key→ LOCK key; In LOCK key mode, all keys except LOCK key of the remote control can't work . (NOTE: In LOCK key mode, the remote and operation panel of the unit both will be locked automatically by pressing the key and press the key again, they will be unlocked. As for the split unit, it only holds the control rather than urgent keys and the panel will make a reaction.)

L. LAMP key:

The default state is in no LAMP key state, press the key to select modes in order: LAMP key →cancel LAMP key→ LAMP key; In LAMP key mode, pressing MODE key can't cancel the show of LAMP key.

M. CLEAN key:

The default state is in no purification state, press the key to select modes in order: CLEAN →cancel CLEAN→ CLEAN; In purification mode, pressing CLEAN key can't cancel purification function. Press the key when the remote control is closed, the control will switch modes in the order: CLEAN →cancel CLEAN→ CLEAN; when you stop the unit and turn on the purification switch, except the wind, the stable swing and air door swing speed aren't adjusted.



## 2.Wired Controller

### VAECR-G001

#### I. Use-method

The control panel of wire controller is responsible for controlling the operation status of the system by the button and displaying the working status of the entire system by its LCD screen, and is responsible for communicating with the control board of the system.



Fig1 Appearance of Wire Controller

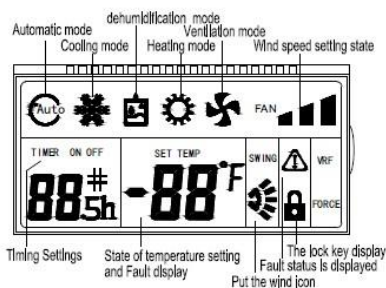

Fig2 LCD display content of Wire Controller

#### Operation and Instruction:

##### "ON/OFF" Button:

- 1) Control the On/Off status of the system.
- 2) Press and hold the On/Off button when the wire controller is powered on, to go into the self-test mode. And then you can release the button.

##### "MODE" Button:

When the air conditioning is powered on, every time you press mode button or the mode button of remote controller, the mode will change in the following sequence.

Auto Mode→Refrigeration→Dehumidification→Heating→Ventilation→Auto Mode

##### "TEMP+" and "TEMP-" Button ("▲", "▼") :

- 1) Boot state, press "▲" and "▼"Button, increase/decrease the setting temperature . Refrigeration, Dehumidification, Ventilation and Heating mode Scope of temperature setting: 16 °C ~ 32 °C ; The setting temperature do not adjust in Auto Mode .

- 2) Press the "▲" and "▼" button for 3s simultaneously to lock this button. At this time, It will display the locking icon in LCD. Deactivate this button, and press the "▲" and "▼" button again simultaneously.

##### "TIMER" Button

Set Timing On or Timing Off. The wire controller to set the time range as 1-24h.

- 1) Press the Timer button in the Off status to go into the Timing On for 1 hour, and then press the Timer button plus 1 until it is timing on for 24h. At this time, if you press the Timer button, it will deactivate Timing On.

- 2) Press the Timer button in the On status to go into the Timing Off for 1 hour, and then press the Timer button plus 1 until it is timing off for 24h. At this time, if you press the Timer button, it will deactivate Timing Off.

##### "FAN SPEED" Button:

- 1) The Fan Speed button is valid in the "Cooling mode", "Heating mode" and "Ventilation mode".

- 2) Press the Fan Speed button of the wire controller or the Volume button of the remote controller in the Cooling mode, Heating mode or Ventilation mode, and the volume changes as follows:

High speed → Middle speed → Low speed → Auto wind

- 3) There is no Auto wind in the Ventilation mode.

##### "SWING" Button:

- 1) Press it to display the Swing icon. The Swing icon will swing back and forth.
- 2) Press the Swing button, and the upper and lower wind deflectors will swing within the specified range automatically, and the left and right wind deflectors will swing within the specified range automatically, and press it again to stop the swing.

##### 26°C/CHECK Button Function:

- 1) Short press this button , Enter a state of energy saving of 26 °C, namely the setting temperature is 26 °C. this function under the boot of Refrigeration and Heating mode is effective.

- 2) Long press this button , will enter the query condition: It will exit the query condition , when you press this button again and five seconds is not operating in the condition of the query.

By pressing "▲" and "▼"Button to check the temperature in the query condition. 1 is Indoor environment temperature , 2 is Indoor pipe temperature , 3 is outdoor pipe temperature

##### Description of DIP Switch :

	2 ON	2 OFF
3 ON	-4°C	-2°C
3 OFF	2°C	0°C
	ON	OFF
1	The old protocol	The new protocol
4	with power failure memory	without power failure memory

- 1) The second and third bits of the DIP switch will select the compensation value of the indoor temperature. The compensation value is -4°C when the second and third bits are ON, and the compensation value is 0°C when the second and third bits are OFF. The compensation value is 2°C when the second bit is ON and the third bit is OFF, and the compensation value is -2°C when the second bit is OFF and the third bit is On (for the wire controller sensor only).

- 2) The first bit of the DIP switch indicates to select the new or old protocol. Light commercial units select the new protocol.

- 3) The fourth bit ON of the DIP switch indicates it is With Power Failure Memory function, and the fourth bit OFF indicates it is Without Power Failure Memory.

NOTE: Just need to dial the code when matching the old type . Detailed please see after-sales guidance !

## II. Installation of Wire Controller

### Safety Precautions

- ! Read the safety precautions carefully before installation.
- ! The following is the important content to be paid for the safety, be sure to follow it.
- ! The meaning of each part:

<b>Warning:</b>	Indicate it may cause the death or serious injury for their improper operation.
<b>Note:</b>	Indicate it may cause the death or serious injury for their improper operation.

#### Notes:

- Please do not install the wire controller in damp or direct sunlight places.
- Please do not hit, throw and frequent disassembling the wire controller.
- Please do not operating the wire controller with Wet hand ; Don't make any fluid into the wire controller .
- Please do not do dismantling the wire controller without authorization. Please consult after-sales maintenance personnel if you have a problem .
- To prevent water and dust into the wire controller, Affect the wire controller normal use. Please dismantle the wire controller When the indoor decoration and maintenancee .

### Installation and disassembly of the wire controller

#### 1. The installation position and requirements of the wire controller

- 1) Please do not install the wire controller in damp or direct sunlight places.
- 2) Please do not install the wire controller in the places, where is near the high temperature or easy to splash water.
- 3) To avoid the interference of the neighbors' remote controller which has the same model , then cause abnormal work. Please do not install the wire controller where the face up to the window.
- 4) Before installation , please cut off the power which is Buried in the wall mounting holes. The whole installation process does not allow operation with power.
- 5) In order to avoid the unit by reason of electromagnetic interference caused by abnormal work . When wiring , please pay attention to the following matters.
  - A) Ensure that communication line access right, otherwise will lead to communication failures.
  - B) If the air conditioning unit is installed on the places , which is influence by electromagnetic interference . the wire controller signal lines must use shielded twisted-pair cable .
  - 6) The standard accessories which is installation need to prepare : installed inside a wall socket bottom box, controller base plate, screw the M4 x 25, control panel.

#### 2. The installation of the wire controller

First of all, the wire controller signal line connection mode is as follows:

- 1) Open interior electrical lifted the lid, and the signal wires through the rubber ring;
- 2) Plug the wire controller signal lines within the five core needle base on the indoor machine circuit boards, and using cable tie line tied tightly fixed.

Next, the wire controller installation steps as shown in the figure below:

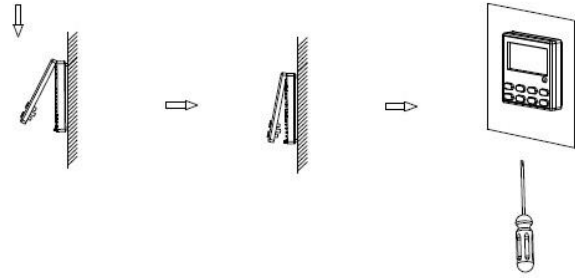
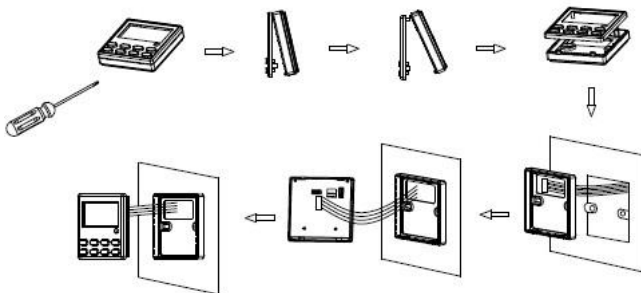

Connect the wire controller in the way as shown in the figure below

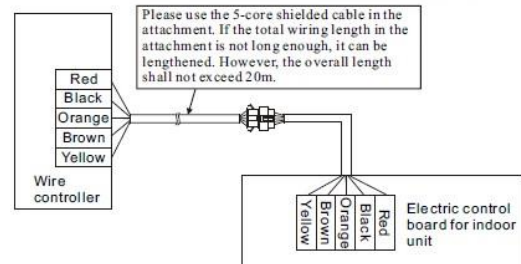

Brief description of the installation process is as follows

- 1) The signal lines of short through rectangle hole of the wire controller bottom plate, and then pull out five core twisted pair from the wall installation hole. Finally connect the line and the other end.
- 2) Use screws M4 x 25 to fix the controller base plate on the mounting holes of the wall.
- 3) Put the wire controller panel and floor buttons together, and this installation is complete. When installation, please reserve a certain length of the line at the bottom of box, to facilitate maintenance later removed.

#### 3. Disassembly of the wire controller

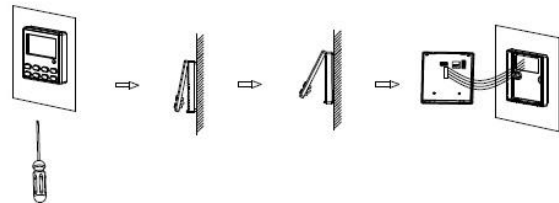

! After the completion of the installation, confirm there is no abnormality for the commissioning, and deliver the instruction to customers for storage.

#### Note:

- It may cause the rear cover deformed if the screw is tightened too much.
- It is necessary to reserve a certain length for the connecting cable of the wire controller during the installation, so as to take down the wire controller for the maintenance.





**OMEGA**  
ENVIRONMENTAL  
TECHNOLOGIES LLC.

17702 Mitchell North, #101  
Irvine, CA. 92614 .USA  
Tel: 714 795 2830  
Fax: 714 966 1646  
info@omegavrf.com  
www.omegavrf.com

**OTEC**<sup>TM</sup>  
AIR CONDITIONING

**Showroom & Technology Center**  
11380 Interchange Circle North  
Miramar, FL 33025 .USA  
Tel: 305 901 1270  
Fax: 954 212 8280  
info@otecvrf.com  
wwwotecvrf.com