

CAQ Series - Silent Bathroom Fan

Description and Applications

CAQ is a highly efficient, super low-noise Bathroom fan designed for continuous use. It holds certifications from HVI and ETL, ensuring it meets high industry standards. Ideal for single-family homes, apartments, offices, and condominiums, CAQ model is not only versatile but also energy-efficient, being an ENERGY STAR-certified product. Its integration into various spaces underscores its commitment to enhancing indoor air quality, making it a valuable addition to modern living and working environments.



Dimensions:

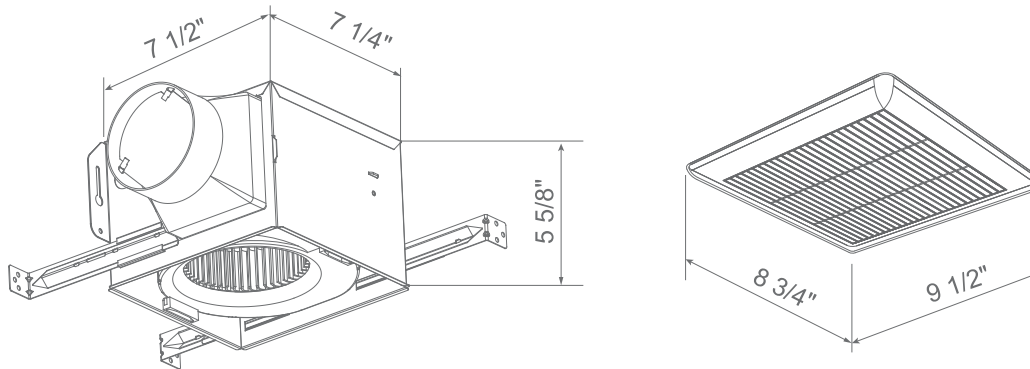

Specifications:

	Duct (in.)	Air Delivery (CFM)		Sound level (sones)		Power Rating (V/Hz)
		@ 0.1" Ps	@ 0.25" Ps	@ 0.1" Ps	@ 0.25" Ps	
CAQ-ES50-F01	4	50	38	0.4	1.0	120/60
CAQ-ES80-F01	4	80	71	1.0	1.5	120/60
CAQ-ES100-F01	4	100	89	2.0	2.0	120/60

Project

PROJECT:				ARCHITECT:		
LOCATION / JOB:				ENGINEER:		
CONTRACTOR:				SUBMITTED BY:		
FAN MODEL:	CFM:	SP:	WATTS:	REMARKS:	DATE:	