

# OMEGA MINI VRF ULTIMA

## SUBMITTAL DATA

**220-240V/1/50Hz**

Job: SPYGLASS  
Location: Jamaica  
Schedule No.: 10218  
System Designation: MINI VRF Systems

Engineer: \_\_\_\_\_  
Architect: \_\_\_\_\_  
Location: \_\_\_\_\_  
Date: \_\_\_\_\_

Approval      Review      Construction

### FEATURES

- Anti-Corrosion Protection
- Refrigerant-Cooled PCB Board
- Welding Free Branch Piping
- Linear Capacity Match with IDU
- Automatic Fault Detection
- Intelligent Soft Start

Models: 30~50 Kbtu/h



Models: 60~70 Kbtu/h

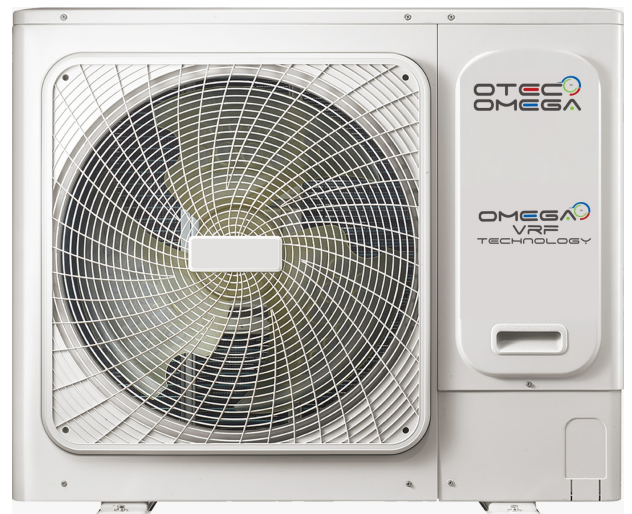

# 1 Specifications

## BCSF Mini VRF Ultima

Model name		BCSF030N0A4-DTM090	BCSF040N0A6-DTM115	BCSF050N0A7-DTM140	
Power supply		1 phase, 220-240V, 50/60Hz			
Cooling <sup>1</sup>	Capacity	kBtu/h	30,000	40,000	50,000
		kW	8.80	11.0	13.2
	Power input	kW	2.01	2.35	3.18
	EER (Btu/w)		14.94	12.90	11.46
Connectable indoor unit	Total Capacity Btuh(Min/Max)		13,650~35,480	17,060~44,360	20,470~53,230
	Quantity		1~4	1~5	1~6
Compressors	Type		DC inverter	DC inverter	DC inverter
	Quantity		1	1	1
	Oil type		FV50S	FV50S	FV50S
Fan	Motor type		DC	DC	DC
	Quantity		1	1	1
	Motor input	W	112	112	112
	Motor output	W	90	90	90
Air flow rate		m <sup>3</sup> /h	3400	3400	3400
Refrigerant	Type		R410A		
	Factory charge	kg (lbs.)	1.4 (3.1)	1.4 (3.1)	1.4 (3.1)
Pipe connections <sup>2</sup>	Liquid pipe	mm (in.)	Φ9.5 (Φ3/8)	Φ9.5 (Φ3/8)	Φ9.5 (Φ3/8)
	Gas pipe	mm (in.)	Φ15.9 (Φ5/8)	Φ15.9 (Φ5/8)	Φ15.9 (Φ5/8)
Sound pressure level <sup>3</sup>		dB(A)	54	54	54
Net dimensions (W×H×D)	mm		973×862×355	973×862×355	973×862×355
	in.		38-5/16×33-15/16×13-31/32	38-5/16×33-15/16×13-31/32	38-5/16×33-15/16×13-31/32
Packed dimensions (W×H×D)	mm		1025×910×410	1025×910×410	1025×910×410
	in.		40-23/64×35-53/64×16-9/64	40-23/64×35-53/64×16-9/64	40-23/64×35-53/64×16-9/64
Net weight		kg (lbs.)	58 (128)	58 (128)	58 (128)
Gross weight		kg (lbs.)	63 (139)	63 (139)	63 (139)
Operating temperature range		°C (°F)	-5 to 48 (23 to 118.4)		

**Notes:**

- Indoor air temperature 27°C (80.6°F) DB, 19°C (66.2°F) WB; outdoor air temperature 35°C (95.0°F) DB; equivalent refrigerant piping length 5.0m (16.4ft.) with zero level difference.
- Diameters given are those of the unit's stop valve.
- Sound pressure level is measured at a position 1m (3.28ft.) in front of the unit and 1.3m (4.26ft.) above the floor in a semi-anechoic chamber.
- The above data may be changed without notice for future improvement on quality and performance.

<b>Conversion Formulae:</b> kBtu/h = kW × 3.412; in.W.G. = Pa × 0.004; lbs. = kg × 2.2; in. = mm / 25.4
---

**1 Specifications**
**BCSF Mini VRF Ultima**

Model name			BCSF060N0A8-DTM160	BCSF070N0A9-DTM190
Power supply			1 phase, 220-240V, 50/60Hz	
Cooling <sup>1</sup>	Capacity	kBtu/h	60,000	70,000
		kW	15.40	17.60
	Power input	kW	4.38	4.77
	EER (Btu/w)		12.0	12.59
Connectable indoor unit	Total Capacity Btuh(Min/Max)		23,880~62,100	27,300~70,970
	Quantity		1~8	1~9
Compressors	Type		DC inverter	DC inverter
	Quantity		1	1
	Oil type		FV50S	FV50S
Fan	Motor type		DC	DC
	Quantity		1	1
	Motor input	W	250	250
	Motor output	W	200	200
Air flow rate		m <sup>3</sup> /h	5100	5100
Refrigerant	Type		R410A	
	Factory charge	kg (lbs.)	2.6 (5.7)	2.6 (5.7)
Pipe connections <sup>2</sup>	Liquid pipe	mm (in.)	Φ9.5 (Φ3/8)	Φ9.5 (Φ3/8)
	Gas pipe	mm (in.)	Φ15.9 (Φ5/8)	Φ15.9 (Φ5/8)
Sound pressure level <sup>3</sup>		dB(A)	55	55
Net dimensions (W×H×D)		mm	1040x865x523	1040x865x523
		in.	40-15/16×34-1/16×20-19/32	40-15/16×34-1/16×20-19/32
Packed dimensions (W×H×D)		mm	1120x980x560	1120x980x560
		in.	44-3/32×38-37/64×22-3/64	44-3/32×38-37/64×22-3/64
Net weight		kg (lbs.)	85 (187)	85 (187)
Gross weight		kg (lbs.)	99.5 (202)	99.5 (202)
Operating temperature range		°C (°F)	-5 to 48 (23 to 118.4)	

**Notes:**

- Indoor air temperature 27°C (80.6°F) DB, 19°C (66.2°F) WB; outdoor air temperature 35°C (95.0°F) DB; equivalent refrigerant piping length 5.0m (16.4ft.) with zero level difference.
- Diameters given are those of the unit's stop valve.
- Sound pressure level is measured at a position 1m (3.28ft.) in front of the unit and 1.3m (4.26ft.) above the floor in a semi-anechoic chamber.
- The above data may be changed without notice for future improvement on quality and performance.

Conversion Formulae: kBtu/h = kW × 3.412; in.W.G. = Pa × 0.004; lbs. = kg × 2.2; in. = mm / 25.4
--

2 Dimensional Drawings - (MM)

Models: 30~50 Kbtu/h

model front view dimensions

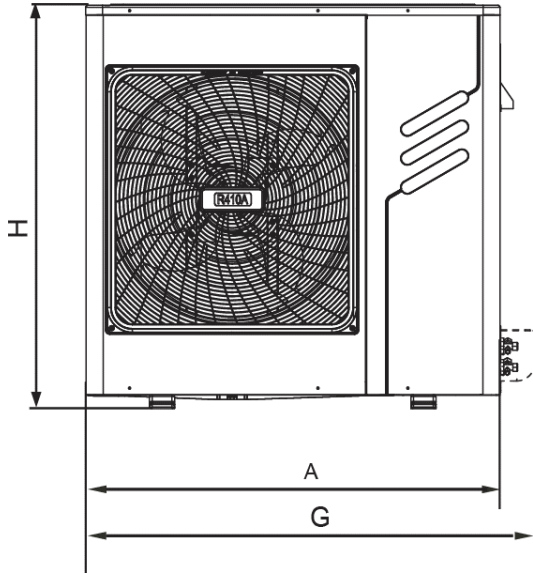

model top view dimensions

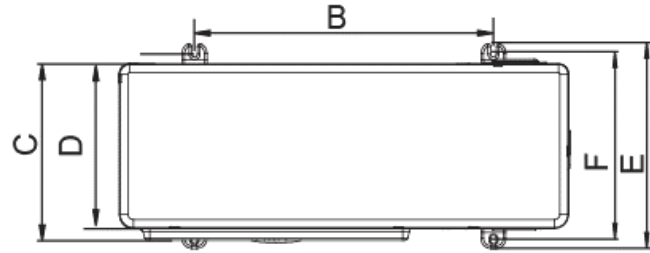

Models: 60~70 Kbtu/h

model front view dimensions

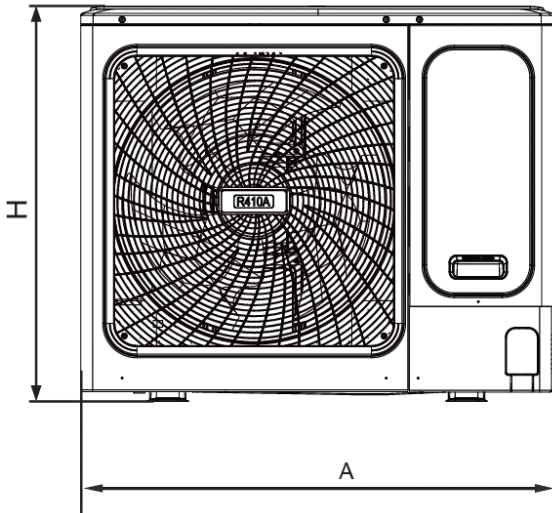

model front top dimensions

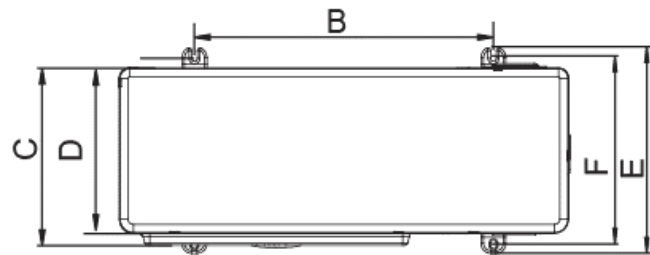

Table 2-2.1: Outdoor unit dimensions (unit: mm)

Model	A	B	C	D	E	F	G	H
30/40/50	895	590	346	302	355	333	973	862
60/70	1040	656	452	410	523	463	--	865



## Installation Space Requirements - (MM)

Single unit installation top view (unit: mm)

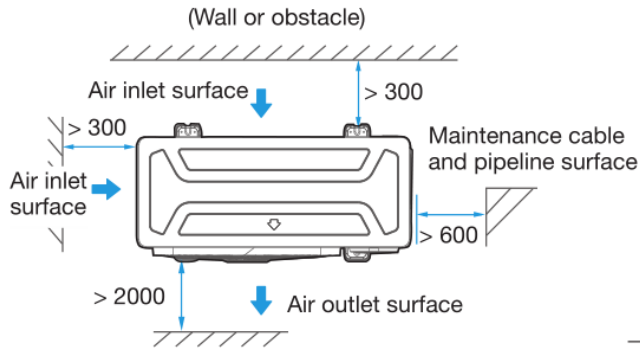

Single unit installation side view (unit: mm)

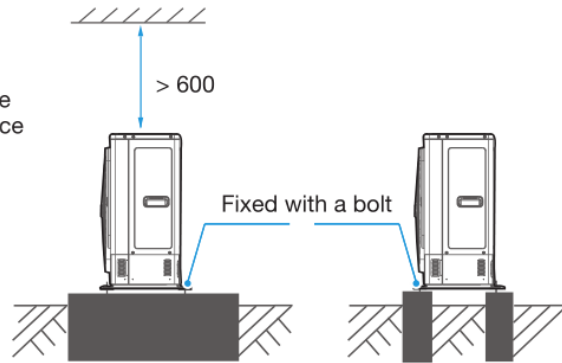

Multiple unit installation top view (unit: mm)

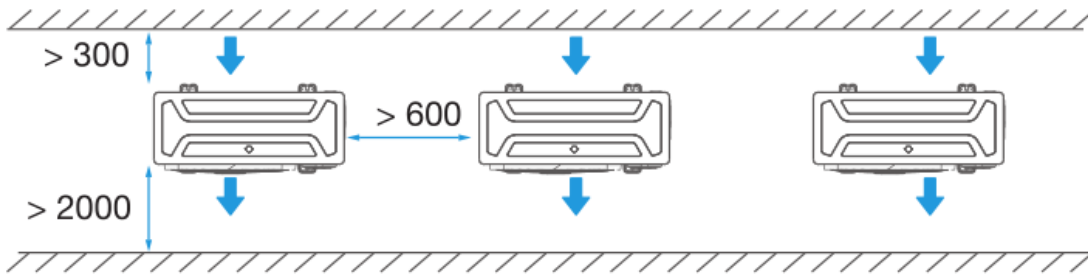

Multiple unit installation side view (unit: mm)

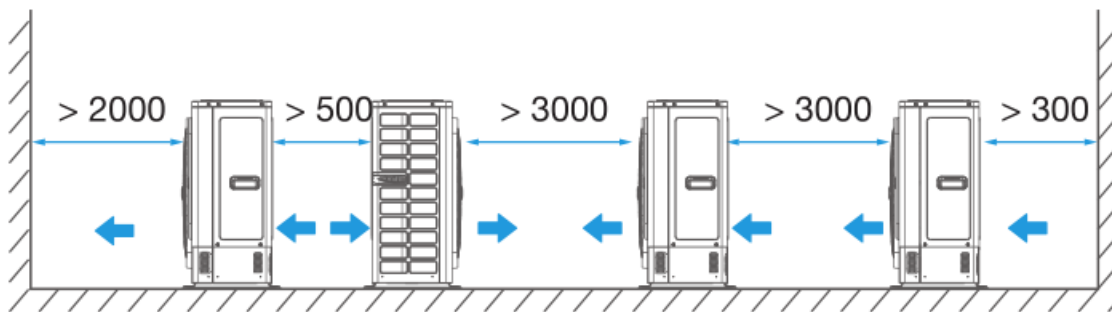

## 3-Electrical Characteristics

Capacity	Power supply <sup>1</sup>						Compressors		Outdoor fan motors		
	Hz	Volts	Min. volts	Max. volts	MCA <sup>2</sup>	TOCA <sup>3</sup>	MFA <sup>4</sup>	MSC <sup>5</sup>	RLA <sup>6</sup>	Rated motor output (kW)	FLA
BCSF030N0A4-DTM090	50/60	220-240	187	253	23.0	25.0	30		9.7	0.09	1.0
BCSF040N0A6-DTM115	50/60	220-240	187	253	23.0	25.0	30	-	9.7	0.09	1.0
BCSF050N0A7-DTM140	50/60	220-240	187	253	23.0	25.0	30	-	9.7	0.09	1.0
BCSF060N0A8-DTM160	50/60	220-240	187	253	33.0	34.0	40	-	14.8	0.20	1.7
BCSF070N0A9-DTM190	50/60	220-240	187	253	33.0	34.0	40	-	14.8	0.20	1.7

**Abbreviations:**

MCA: Minimum Circuit Amps  
 TOCA: Total Over-current Amps  
 MFA: Maximum Fuse Amps  
 MSC: Maximum Starting Current (A)  
 RLA: Rated Load Amps  
 FLA: Full Load Amps

**Notes:**

- Units are suitable for use on electrical systems where voltage supplied to unit terminals is not below or above listed range limits. Maximum allowable voltage variation between phases is 2%.
- Select wire size based on the value of MCA.
- TOCA indicates the total overcurrent amps value of each OC set.
- MFA is used to select overcurrent circuit breakers and residual-current circuit breakers.
- MSC indicates the maximum current on compressor start-up in amps.
- RLA is based on the following conditions: indoor temperature 27°C DB, 19°C WB; outdoor temperature 35°C DB.